

**UNIT, DIRECT SUPPORT AND  
GENERAL SUPPORT MAINTENANCE MANUAL**

**FOR**

**TRUCK, TRACTOR, LINE HAUL:  
52,000 GVWR, 6 X 4, M915A4  
(NSN 2320-01-458-1207) (EIC: B4M)**

**TRUCK, TRACTOR, LINE HAUL:  
54,000 GVWR, 6 X 4, M915A4R2  
(NSN 2320-01-531-9962) (EIC: BFV)**

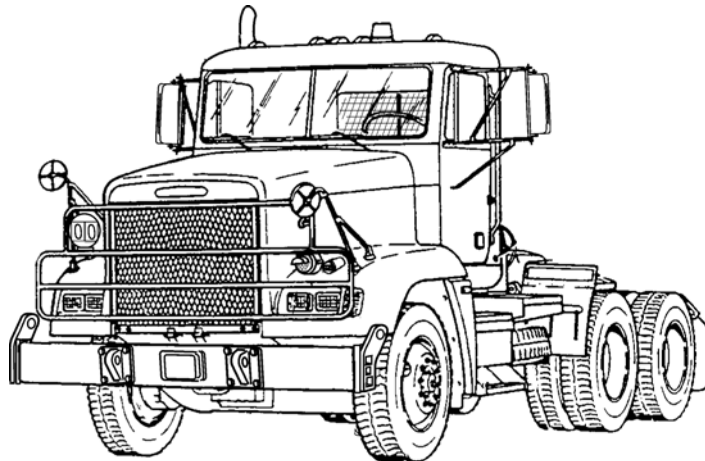
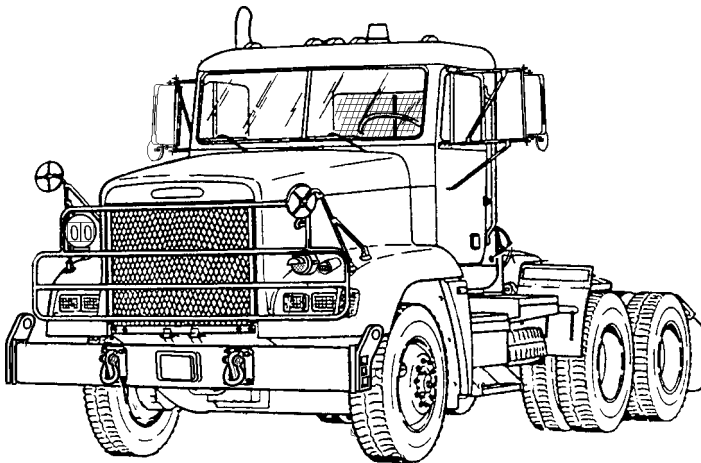

Approved for public release; distribution is unlimited.

---

**HEADQUARTERS, DEPARTMENT OF THE ARMY**

**DECEMBER 2005**



## WARNING SUMMARY

This warning summary contains general safety warnings and hazardous materials warnings that must be understood and applied during operation and maintenance of this equipment. Failure to observe these precautions could result in serious injury or death to personnel. Also included are explanations of safety and hazardous materials icons used within the technical manual.



**BIOLOGICAL** - abstract symbol bug shows that a material may contain bacteria or viruses that present a danger to life or health.



**CHEMICAL** - drops of liquid on hand shows that the material will cause burns or irritation to human skin or tissue.



**EAR PROTECTION** - headphones over ears shows that noise level will harm ears.



**ELECTRICAL** - electrical wire to arm with electricity symbol running through human body shows that shock hazard is present.



**EYE PROTECTION** - person with goggles shows that the material will injure the eyes.



**FIRE** - flame shows that a material may ignite and cause burns.

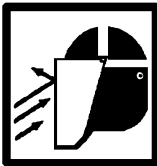

**FLYING PARTICLES** - arrows bouncing off face with face shield shows that particles flying through the air will harm face.



**HEAVY OBJECT** - human figure stooping over heavy object shows physical injury potential from improper lifting technique.



HEAVY PARTS - hand with heavy object on top shows that heavy parts can crush and harm.



HEAVY PARTS - heavy object on human figure shows that heavy parts present a danger to life or limb.



HOT AREA - hand over object radiating heat shows that part is hot and can burn.



VAPOR - human figure in a cloud shows that material vapors present a danger to life or health.



**FOR INFORMATION ON FIRST AID, REFER TO FM 21-11.**



**WARNING**

***CARBON MONOXIDE (EXHAUST GASES) CAN KILL!***

- Carbon monoxide is a colorless, odorless, deadly poison which, when breathed, deprives the body of oxygen and causes suffocation. Exposure to air containing carbon monoxide produces symptoms of headache, dizziness, loss of muscular control, apparent drowsiness, and coma. Permanent brain damage or death can result from severe exposure.
  - Carbon monoxide occurs in exhaust fumes of internal combustion engines. Carbon monoxide can become dangerously concentrated under conditions of inadequate ventilation. The following precautions must be observed to ensure safety of personnel when engine of truck is operated.
1. DO NOT operate vehicle in an enclosed area unless exhaust is vented to outside atmosphere.
  2. DO NOT drive truck with inspection plates or cover plates removed.
  3. BE ALERT for exhaust poisoning symptoms. They are:
    - Headache
    - Dizziness
    - Sleepiness
    - Loss of muscular control
  4. If you see another person with exhaust poisoning symptoms:
    - Remove person from area.
    - Expose to fresh air.
    - Keep person warm.
    - Do not permit physical exercise.
    - Administer cardiopulmonary resuscitation (CPR), if necessary.
    - Notify a medic.
  5. BE AWARE. The field protective mask for nuclear-biological-chemical (NBC) protection will not protect you from carbon monoxide poisoning.

***The Best Defense Against Carbon Monoxide Poisoning Is Good Ventilation!***



**WARNING**



***ADHESIVES AND SEALING COMPOUNDS***

Adhesives and sealing compounds can burn easily, can give off harmful vapors, and are harmful to skin and clothing. To avoid injury or death, keep away from open fire and use in a well-ventilated area. If adhesive or sealing compound contacts skin or clothing, wash immediately with soap and water.



**WARNING**

***AIR LINES AND FITTINGS***

- DO NOT disconnect any air system lines or fittings unless vehicle engine is shut down and air system pressure is relieved. Failure to follow this warning could result in serious injury to personnel.
- Ensure that all air lines and fittings are clear of debris and excess pipe sealing compound does not enter air lines or fittings. Failure to follow this warning could result in injury to personnel and damage to equipment.
- Always wear eye protection when disconnecting air lines. Residual air will be expelled. Failure to follow this warning may result in serious eye injury.



**WARNING**

***BATTERIES***



- To avoid eye injury, eye protection is required when working around batteries. DO NOT smoke, use open flame, make sparks or create other ignition sources around batteries. If a battery is giving off gases, it can explode and cause injury to personnel. Remove all jewelry such as rings, ID tags, watches, and bracelets. If jewelry or a tool contacts a battery terminal, a direct short will result in instant heating, injury to personnel, and damage to equipment.
- Sulfuric acid contained in batteries can cause serious burns. Always wear goggles, gloves, and apron. If battery corrosion or electrolyte makes contact with skin, eyes or clothing, take immediate action to stop the corrosive burning effects. Failure to follow these procedures may result in death or serious injury to personnel.
  1. **Eyes.** Flush with cold water for no less than 15 minutes and seek medical attention immediately.
  2. **Skin.** Flush with large amounts of cold water until all acid is removed. Seek medical attention as required.
  3. **Internal.** If corrosion or electrolyte is ingested, drink large amounts of water or milk. Follow with milk of magnesia, beaten egg or vegetable oil. Seek medical attention immediately.
  4. **Clothing/Equipment.** Wash area with large amounts of cold water. Neutralize acid with baking soda or household ammonia.

**WARNING**

***BRAKES***

- When caging brakes, block wheels to keep truck from moving when brakes are released. Failure to follow this warning may result in death or injury to personnel or damage to equipment.
- Brake chamber contains spring under great pressure. To prevent personnel injury, never work directly behind chamber. If caging bolt will not engage properly, spring may be broken.
- DO NOT remove clamp ring around spring brake chamber. It is under tension and can cause personnel injury if released.
- When spring brakes are applied, vehicle will stop quickly which could result in injury to personnel. Also, vehicle cannot be driven again until malfunction is repaired and enough air supply is present for operation of service brakes.

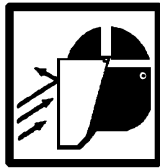

**WARNING**

***COMPRESSED AIR***

Compressed air used for cleaning or drying purposes, or for clearing restrictions, should never exceed 30 psi (207 kPa). Wear protective clothing (goggles/shield, gloves, etc.) and use caution to avoid injury to personnel.



**WARNING**

***DIESEL FUEL HANDLING***



- DO NOT perform fuel system checks, inspections or maintenance while smoking or near fire, flames or sparks. Fuel may ignite, causing injury or death to personnel and damage to vehicle.
- Fuel vapors are toxic. Avoid prolonged exposure or breathing of fumes. Work in a well-ventilated area. Failure to follow this warning could result in serious injury to personnel.
- Personnel must wear fuel-resistant gloves when handling fuels. If exposed to fuel, promptly wash exposed skin and change fuel-soaked clothing.



**WARNING**



***ETHER QUICK-START SYSTEM***

Ether fuel is extremely flammable and toxic. DO NOT smoke and make sure you are in a well-ventilated area away from heat, open flames or sparks. Wear goggles and chemical resistant gloves. Avoid contact with skin and eyes and avoid breathing vapors. If fluid enters or fumes irritate the eyes, wash immediately with large quantities of clean water for 15 minutes. Seek medical attention immediately if ether is inhaled or causes eye irritation. Failure to follow this warning may cause death or serious injury to personnel.



**WARNING**

***FIRE EXTINGUISHER***

Discharging large quantities of dry chemical fire extinguisher in cab may result in temporary breathing difficulty during and immediately after the discharge event. If at all possible, discharge fire extinguisher from outside the cab. Avoid unnecessary contact during use and cleanup. Contact local medical personnel to determine necessary personal protective equipment to wear during cleanup.



**WARNING**

***HAZARDOUS WASTE DISPOSAL***

When servicing this vehicle, performing maintenance, or disposing of materials such as engine coolant, transmission fluid, lubricants, battery acids or batteries, and CARC paint, consult your unit/local hazardous waste disposal center or safety office for local regulatory guidance. If further information is needed, please contact The Army Environmental Hotline at 1-800-872-3845.



**WARNING**

***HEARING PROTECTION***

Hearing protection is required when operating vehicle at more than 40 mph (64 kph) with windows open for an extended period of time. Hearing protection is also required when personnel are within 5.2 ft (1.57 m) of vehicle when operating at low engine idle (600 rpm) and within 16.5 ft (5 m) of vehicle when operating at high idle (1600 rpm). Failure to follow this warning may result in hearing damage.



**WARNING**

***NBC EXPOSURE***

If NBC exposure is suspected, all air cleaner media should be handled by personnel wearing protective equipment. Consult your NBC Officer or NBC NCO for appropriate handling or disposal procedures.



***To order this NBC decal use:***

National Stock Number (NSN) - 7690-01-114-3702  
 Part Number (PN) - 12296626  
 Commercial and Government Entity Code (CAGEC) - 19207



**WARNING**

***PRESSURIZED COOLING SYSTEM***

DO NOT remove radiator cap or drain antifreeze unless engine is cold. Remove radiator cap in two steps. First, place a thick cloth over cap and slowly turn cap left to first stop. Pause and allow pressure to escape. Turn cap further left until it can be removed. This is a pressurized cooling system and escaping steam, hot water or coolant will cause serious burns.



**WARNING**

***R-134A REFRIGERANT***



- Liquid refrigerant, when exposed to air, quickly evaporates and will freeze skin or eye tissue. Use care to prevent refrigerant from touching your skin or eyes. Serious injury or blindness may result if you come in contact with refrigerant.
- Refrigerant R-134a air conditioning systems should not be pressure tested or leak tested with compressed air. Combustible mixtures of air and R-134a may form, resulting in a fire or explosion, which could cause personnel injury.
- DO NOT work in an area where refrigerant may contact an open flame or burning material such as a cigarette. When refrigerant contacts extreme heat, refrigerant breaks down into poisonous phosgene gas which, if breathed, causes severe respiratory irritation. DO NOT breathe fumes from an open flame leak detector.



**WARNING**

***SLAVE STARTING***

- When slave starting truck, use NATO slave cable that DOES NOT have loose or missing insulation.
- DO NOT proceed if suitable cable is not available.
- DO NOT use civilian-type jumper cables.
- Failure to follow this warning could result in injury to personnel and damage to equipment.

**WARNING**

***TIRE CHANGING***

Whenever wheel lug nuts require tightening or a wheel has been removed and replaced, lug nuts must be tightened to the required torque. Failure to follow this warning may result in serious injury to personnel and damage to equipment.

**WARNING**

***TOWING***

Brakes will be released when air is applied to a disabled vehicle. DO NOT connect air lines to a disabled vehicle without blocking wheels and connecting tow bar between vehicles. Failure to follow this warning could result in death or injury to personnel and damage to equipment.

**WARNING**

***WORK SAFETY***



- Hydraulic jack is intended only for lifting truck, not for supporting vehicle to perform maintenance. DO NOT get under truck after it is raised unless it is properly supported with blocks or jackstands. Failure to observe this warning may result in death or injury to personnel.



- Use extreme caution when handling heavy parts. Provide adequate support and use assistance during procedure. Ensure that any lifting device used is in good condition and of suitable load capacity. Keep clear of heavy parts supported only by lifting device. Failure to follow this warning may result in death or injury to personnel.



- Improper use of lifting equipment and improper attachment of cables to vehicle can result in serious personnel injury and equipment damage. Observe all standard rules of safety.



- ALWAYS install hood prop after opening hood. Failure to follow this warning could result in severe injury to personnel.

TECHNICAL MANUAL  
TM 9-2320-303-24-2  
Change No. 1

HEADQUARTERS  
DEPARTMENT OF THE ARMY  
Washington, D.C., 28 February 2007

**UNIT, DIRECT SUPPORT, AND GENERAL SUPPORT MAINTENANCE MANUAL**

**FOR**

**TRUCK, TRACTOR, LINE HAUL:  
52,000 GVWR, 6 X 4, M915A4  
(NSN 2320-01-458-1207) (EIC: B4M)**

**TRUCK, TRACTOR, LINE HAUL:  
54,000 GVWR, 6 X 4, M915A4R2  
(NSN 2320-01-531-9962) (EIC: BFV)**

TM 9-2320-303-24-2, 30 December 2005, is updated as follows:

Remove old pages and insert new pages:

**Remove Pages**

*Cover  
A and B  
i and vi*

**Insert Pages**

*Cover  
A and B  
i and vi  
DA Form 2028*

1. Replace the following work packages with their revised version:

*Work Package Number  
WP 0222 00  
WP 0236 00 through WP 0241 00  
WP 0244 00 through WP 0246 00  
WP 0248 00 and WP 0249 00  
WP 0265 00  
WP 0282 00  
WP 0306 00 and WP 0307 00  
WP 0309 00  
WP 0313 00  
Foldouts*

2. Add the following new work packages:

*Work Package Number  
WP 0248 01  
WP 0249 01  
WP 0265 01*

TM 9-2320-303-24-2

C1

By Order of the Secretary of the Army:

PETER J. SCHOOMAKER  
*General, United States Army*  
*Chief of Staff*

Official:

  
JOYCE E. MORROW  
*Administrative Assistant to the*  
*Secretary of the Army*  
0609502

**DISTRIBUTION:** To be distributed in accordance with the initial distribution requirements for IDN: 381144, requirements for TM 9-2320-303-24-2.



**LIST OF EFFECTIVE PAGES/WORK PACKAGES**

**NOTE**

Dates of issue for original and change pages/work packages are:

Original            30 December 2005  
 Change             28 February 2007

**TOTAL NUMBER OF PAGES FOR FRONT AND REAR MATTER IS 46 AND TOTAL NUMBER OF WORK PACKAGES IS 95 CONSISTING OF THE FOLLOWING:**

<b>Page/WP No.</b>	<b>*Change No.</b>
Cover (Back Blank)	1
a through h	0
A (B Blank)	1
i to ix (x Blank)	0
WP 0222 00	1
WP 0223 00 through WP 0235 00	1
WP 0236 00 through WP 0241 00	1
WP 0242 00 and WP 0243 00	0
WP 0244 00 through WP 0246 00	1
WP 0247 00	0
WP 0248 00 through WP 0249 01	1
WP 0250 00 through WP 0264 00	0
WP 0265 00 and WP 0265 01	1
WP 0266 00 through WP 0281 00	0
WP 0282 00	1
WP 0283 00 through WP 0305 00	0
WP 0306 00 and WP 0307 00	1
WP 0308 00	0
WP 0309 00	1
WP 0310 00 through WP 0312 00	0
WP 0313 00	1
Foldout FO-1	0
Foldout FO-2 through FO-16	1
Index-1 thru Index-6	0
Authentication Page (Back Blank)	0
Sample DA Form 2028	1
DA Form 2028	1
Metric Conversion Chart	0
Back Cover	1

\* Zero in this column indicates an original page or work package.

**A/(B Blank)**



UNIT, DIRECT SUPPORT  
AND GENERAL SUPPORT MAINTENANCE MANUAL

FOR

TRUCK, TRACTOR, LINE HAUL:  
52,000 GVWR, 6 X 4, M915A4  
(NSN 2320-01-458-1207) (EIC: B4M)

TRUCK, TRACTOR, LINE HAUL:  
54,000 GVWR, 6 X 4, M915A4R2  
(NSN 2320-01-531-9962) (EIC: BFV)

**REPORTING ERRORS AND RECOMMENDING IMPROVEMENTS**

You can help improve this publication. If you find any mistakes or if you know of a way to improve the procedures, please let us know. Submit your DA Form 2028 (*Recommended Changes to Publications and Blank Forms*), through the Internet, on the Army Electronic Product Support (AEPS) website. The Internet address is <https://aeps.ria.army.mil/>. The DA Form 2028 is located under the Public Applications section in the AEPS Public Home Page. Fill out the form and click on SUBMIT. Using this form on the AEPS will enable us to respond quicker to your comments and better manage the DA Form 2028 program. You may also mail, fax or e-mail your letter or DA Form 2028 direct to: AMSTA-LC-LPIT/TECH PUBS, TACOM-RI, 1 Rock Island Arsenal, Rock Island, IL 61299-7630. The e-mail address is: ROCK-TACOM-TECH-PUBS@conus.army.mil. The fax number is DSN 793-0726 or Commercial (309) 782-0726.

**Table of Contents**

	<b>Page Number</b>
<b>VOLUME II</b>	
Warning Summary . . . . .	a
How To Use This Manual . . . . .	v
<b>CHAPTER 4 DIRECT SUPPORT AND GENERAL SUPPORT MAINTENANCE INSTRUCTIONS</b>	
WP 0222 00 Troubleshooting Introduction . . . . .	0222 00-1
WP 0223 00 Troubleshooting Symptom Index . . . . .	0223 00-1
WP 0224 00 Engine Troubleshooting . . . . .	0224 00-1
WP 0225 00 Transmission Troubleshooting . . . . .	0225 00-1
WP 0226 00 Steering System Troubleshooting . . . . .	0226 00-1
WP 0227 00 Air Conditioning System Troubleshooting and Testing . . . . .	0227 00-1
<b>Engine</b>	
WP 0228 00 Power Pack Replacement . . . . .	0228 00-1
WP 0229 00 Engine/Transmission Replacement . . . . .	0229 00-1
WP 0230 00 Engine Mounts Replacement . . . . .	0230 00-1
<b>Cooling</b>	
WP 0231 00 Radiator Repair . . . . .	0231 00-1
WP 0232 00 Fan Clutch Repair . . . . .	0232 00-1

## Table of Contents - Continued

	<b>Page Number</b>
<i>Electrical System</i>	
WP 0233 00 Alternator Repair . . . . .	0233 00-1
WP 0234 00 Starter Solenoid Replacement . . . . .	0234 00-1
WP 0235 00 Starter Repair . . . . .	0235 00-1
WP 0236 00 Main Cab Wiring Harness Replacement . . . . .	0236 00-1
WP 0237 00 Switch Panel Wiring Harness Replacement . . . . .	0237 00-1
WP 0238 00 Turn Signal/Marker Light Wiring Harness Replacement . . . . .	0238 00-1
WP 0239 00 Turn Signal (Thru-Deck) Wiring Harness Replacement . . . . .	0239 00-1
WP 0240 00 Overhead Cab Wiring Harness Replacement . . . . .	0240 00-1
WP 0241 00 Chassis Wiring Harness Replacement . . . . .	0241 00-1
WP 0242 00 Front Anti-Lock Brake System (ABS) Wiring Harness Replacement . . . . .	0242 00-1
WP 0243 00 Rear Anti-Lock Brake System (ABS) Wiring Harness Replacement . . . . .	0243 00-1
WP 0244 00 Taillight Wiring Harness Replacement . . . . .	0244 00-1
WP 0245 00 Engine Wiring Harness Replacement . . . . .	0245 00-1
WP 0246 00 Radio Wiring Harness Replacement . . . . .	0246 00-1
WP 0247 00 Collision Warning System (CWS) Wiring Harness Replacement . . . . .	0247 00-1
<i>Transmission</i>	
WP 0248 00 Transmission Overhaul (M915A4) . . . . .	0248 00-1
WP 0248 01 Transmission Overhaul (M915A4R2) . . . . .	0248 01-1
<i>Front Axle</i>	
WP 0249 00 Front Axle Replacement (M915A4) . . . . .	0249 00-1
WP 0249 01 Front Axle Replacement (M915A4R2) . . . . .	0249 01-1
WP 0250 00 Front Axle Caster Adjustment . . . . .	0250 00-1
WP 0251 00 Tie Rod Maintenance . . . . .	0251 00-1
WP 0252 00 Front Cross Tube Arm Replacement . . . . .	0252 00-1
WP 0253 00 Front Steering Arm Replacement . . . . .	0253 00-1
WP 0254 00 Front Steering Knuckle Replacement . . . . .	0254 00-1
<i>Rear Axle</i>	
WP 0255 00 Rear Axle Replacement . . . . .	0255 00-1
WP 0256 00 Forward-Rear Axle Differential Carrier Replacement . . . . .	0256 00-1
WP 0257 00 Forward-Rear Axle Differential Carrier Repair . . . . .	0257 00-1
WP 0258 00 Rear-Rear Axle Differential Carrier Replacement . . . . .	0258 00-1
WP 0259 00 Rear-Rear Axle Differential Carrier Repair . . . . .	0259 00-1
WP 0260 00 Rear Yoke and Oil Seal Replacement . . . . .	0260 00-1
<i>Brakes</i>	
WP 0261 00 Foot Brake Valve Repair . . . . .	0261 00-1
WP 0262 00 Air Dryer Repair . . . . .	0262 00-1
WP 0263 00 Brake Drum Repair . . . . .	0263 00-1
<i>Steering</i>	
WP 0264 00 Power Steering Pump Replacement . . . . .	0264 00-1
WP 0265 00 Steering Gear Replacement (M915A4) . . . . .	0265 00-1
WP 0265 01 Steering Gear Replacement (M915A4R2) . . . . .	0265 01-1
WP 0266 00 Steering Column Replacement . . . . .	0266 00-1

## Table of Contents - Continued

	<b>Page Number</b>
<i><b>Frame and Towing Attachments</b></i>	
WP 0267 00 Fifth Wheel Replacement . . . . .	0267 00-1
WP 0268 00 Slide Bracket and Plate Repair . . . . .	0268 00-1
WP 0269 00 Fifth Wheel Top Plate Replacement . . . . .	0269 00-1
WP 0270 00 Fifth Wheel Top Plate Repair . . . . .	0270 00-1
WP 0271 00 Ramp Replacement . . . . .	0271 00-1
WP 0272 00 Overslung Crossmember Replacement . . . . .	0272 00-1
WP 0273 00 Cab Alligator Crossmember Replacement . . . . .	0273 00-1
WP 0274 00 Midships Alligator Crossmember Replacement . . . . .	0274 00-1
WP 0275 00 Rear Suspension Crossmember Replacement . . . . .	0275 00-1
WP 0276 00 Rear Crossmember Replacement . . . . .	0276 00-1
WP 0277 00 Front Crossmember Replacement . . . . .	0277 00-1
WP 0278 00 Frame Rail Extension and Reinforcement Replacement . . . . .	0278 00-1
WP 0279 00 Front Engine Mount Support Replacement . . . . .	0279 00-1
WP 0280 00 Front Cab Mounts Replacement . . . . .	0280 00-1
WP 0281 00 Rear Cab Mounts Replacement . . . . .	0281 00-1
<i><b>Springs and Shock Absorbers</b></i>	
WP 0282 00 Front Spring Replacement . . . . .	0282 00-1
WP 0283 00 Front Spring Hangers Replacement . . . . .	0283 00-1
WP 0284 00 Rear Spring and Saddle Assembly Replacement . . . . .	0284 00-1
WP 0285 00 Rear Spring Hanger Replacement . . . . .	0285 00-1
WP 0286 00 Torque Rod Replacement . . . . .	0286 00-1
WP 0287 00 Equalizing Beam Replacement . . . . .	0287 00-1
WP 0288 00 Equalizing Beam Repair . . . . .	0288 00-1
<i><b>Body, Cab, and Hood</b></i>	
WP 0289 00 Cab Body Repair . . . . .	0289 00-1
WP 0290 00 Cab Replacement . . . . .	0290 00-1
WP 0291 00 Hood Sheet Molded Compound (SMC) Repair . . . . .	0291 00-1
WP 0292 00 Cab Door Replacement . . . . .	0292 00-1
WP 0293 00 Cab Door Repair . . . . .	0293 00-1
<i><b>Body and Accessory Items</b></i>	
WP 0294 00 Windshield Replacement . . . . .	0294 00-1
WP 0295 00 Rear Window Replacement . . . . .	0295 00-1
WP 0296 00 Air Ducts Replacement . . . . .	0296 00-1
<i><b>Air Conditioner/Heater Components</b></i>	
WP 0297 00 Air Conditioning System Refrigerant (R-134a) Maintenance . . . . .	0297 00-1
WP 0298 00 Heating, Ventilation, Air Conditioning (HVAC) Unit Replacement . . . . .	0298 00-1
WP 0299 00 Air Conditioner Expansion Valve Replacement . . . . .	0299 00-1
WP 0300 00 Air Conditioner Evaporator Coil Replacement . . . . .	0300 00-1
WP 0301 00 Air Conditioner Compressor Service . . . . .	0301 00-1
WP 0302 00 Air Conditioner Compressor Replacement . . . . .	0302 00-1
WP 0303 00 Air Conditioner Receiver-Dryer Replacement . . . . .	0303 00-1
WP 0304 00 Air Conditioner Condenser Replacement . . . . .	0304 00-1
WP 0305 00 Air Conditioner Hose Replacement . . . . .	0305 00-1
WP 0306 00 General Maintenance Instructions . . . . .	0306 00-1

## Table of Contents - Continued

	<b>Page Number</b>
<b>CHAPTER 5 SUPPORTING INFORMATION</b>	
WP 0307 00	References . . . . . 0307 00-1
WP 0308 00	Maintenance Allocation Chart (MAC) Introduction . . . . . 0308 00-1
WP 0309 00	Maintenance Allocation Chart (MAC) . . . . . 0309 00-1
WP 0310 00	Illustrated List of Manufactured Items . . . . . 0310 00-1
WP 0311 00	Torque Limits . . . . . 0311 00-1
WP 0312 00	Expendable and Durable Items List . . . . . 0312 00-1
WP 0313 00	Tool Identification List . . . . . 0313 00-1
	Main Cab Harness, Fuse, Relay, and Circuit Breakers (M915A4) . . . . . FO-1
	Main Cab Harness, Fuse, Relay, and Circuit Breakers (M915A4R2) . . . . . FO-2
	Switch Panel Wiring Harness Replacement . . . . . FO-3
	Side Marker Light and Thru-Deck Harnesses . . . . . FO-4
	Turn Signal Harness . . . . . FO-5
	Overhead Cab Harness . . . . . FO-6
	Chassis Harness . . . . . FO-7
	Taillight Harness . . . . . FO-8
	Engine Harness . . . . . FO-9
	Radio Harness . . . . . FO-10
	Alternator Cables Replacement . . . . . FO-11
	Index . . . . . Index-1

# HOW TO USE THIS MANUAL

## **INTRODUCTION**

This manual is designed to help you maintain the M915A4 and M915A4R2. There are three volumes.

Volume I contains introductory information and Unit Maintenance troubleshooting and maintenance. Volume II contains Direct and General Support Maintenance troubleshooting and maintenance. Volume III contains troubleshooting procedures for the Generation 4 transmission used in the M915A4R2.

## **FEATURES OF THIS MANUAL**

- A Table of Contents is provided at the beginning of this manual.
- WARNINGS, CAUTIONS, NOTES, subject headings, and other important information are highlighted in **BOLD** print as a visual aid.

## **WARNING**

A WARNING indicates a hazard which results in death or serious injury.

## **CAUTION**

A CAUTION is a reminder of safety practices or directs attention to usage practices that may result in damage to equipment.

## **NOTE**

A NOTE is a statement containing information that will make the procedures easier to perform.

- Statements and words of particular importance are printed in CAPITAL LETTERS to create emphasis.
- Instructions are located with illustrations that show the specific task on which the mechanic is working.
- Numbers located at lower right corner of art (e.g., 342-001, 342-002, 371-001, 371-002, etc.) are art control numbers and are used for tracking purposes. Disregard these numbers.
- Dashed leader lines used in illustrations indicate that called out items are not visible (i.e. they are located within the structure). Dashed leader lines in the Lubrication Chart indicate that lubrication is required on BOTH sides of the equipment.
- Technical instructions include metric units in addition to standard units. A metric conversion chart is provided on the inside back cover.
- An alphabetical index is provided at the end of the manual to assist in locating information not readily found in the Table of Contents.

## **FOLLOW THESE GUIDELINES WHEN YOU USE THIS MANUAL**

- Read through this manual and become familiar with its contents before attempting to maintain the vehicle.
- A Warning Summary is provided at the beginning of this manual and should be read before attempting to maintain the vehicle.





**CHAPTER 4**  
**DIRECT SUPPORT AND GENERAL SUPPORT**  
**MAINTENANCE INSTRUCTIONS**



**INTRODUCTION**

This work package contains introductory information on troubleshooting, testing, and repair of both models. Make sure the problems are real. Be sure the electrical power is on when needed. Refer to the preliminary troubleshooting procedures before you start troubleshooting, and during troubleshooting, when referenced.

**PRELIMINARY TROUBLESHOOTING PROCEDURES****NOTE**

Fluid leaks are classified as either Class I, Class II or Class III.

- Class I:* Seepage of fluid, as indicated by wetness or discoloration, not great enough to form drops.  
*Class II:* Leakage of fluid great enough to form drops, but not enough to cause drops to drip from the item being checked or observed.  
*Class III:* Leakage of fluid great enough to form drops that fall from the item being checked or observed.

Before starting any specific troubleshooting procedures, perform the following:

- a. Visually check for ruptured oil hoses or tubes, and for Class II or Class III leaks.
- b. Check for mechanical jamming or binding caused by rocks or other foreign matter.
- c. Check fluid levels in subject area and service as required (TM 9-2320-303-10 or Unit PMCS).

**END OF WORK PACKAGE**



**TROUBLESHOOTING SYMPTOM INDEX**

**0223 00**

**Malfunction/Symptom Page Number**

**ENGINE**

- 1. Engine Troubleshooting. . . . . 0224 00-1
- 2. Engine Fails to Crank. . . . . 0224 00-1
- 3. Engine Cranks, But Does Not Start. . . . . 0224 00-1
- 4. Engine Runs Erratically. . . . . 0224 00-1
- 5. High Oil Consumption. . . . . 0224 00-1

**TRANSMISSION**

- 1. Transmission Troubleshooting. . . . . 0225 00-1

**STEERING**

- 1. No Recovery. . . . . 0226 00-1
- 2. External Oil Leaks from Steering Gear. . . . . 0226 00-2
- 3. Oversteer or Darting. . . . . 0226 00-3
- 4. High Steering Effort in One Direction. . . . . 0226 00-3
- 5. High Steering Effort in Both Directions. . . . . 0226 00-3

**AIR CONDITIONING SYSTEM**

- 1. Problem - Warm Airflow When Air Conditioning Is On. . . . . 0227 00-7
- 2. Problem - Low Evaporator Coil Outlet Pressure (Low Compressor Suction Pressure). . . . . 0227 00-7
- 3. Problem - High Compressor Discharge Pressure. . . . . 0227 00-7
- 4. Problem - Evaporator Outlet Air Temperature Increases as Compressor Discharge Pressure Drops. . . . . 0227 00-7
- 5. Problem - Compressor Operates Too Often or Continuously. . . . . 0227 00-8
- 6. Problem - Quick or Delayed Cycling of Compressor. . . . . 0227 00-8

**END OF WORK PACKAGE**



**ENGINE TROUBLESHOOTING**

**0224 00**

**THIS WORK PACKAGE COVERS**

Engine Troubleshooting Procedures

**INITIAL SETUP**

**Maintenance Level**

Direct Support

**Materials/Parts**

Rag, wiping (Item 39, WP 0312 00)

**Tools and Special Tools**

Tool kit, general mechanic's (Item 102, WP 0313 00)

**Table 1. Engine Troubleshooting Procedures.**

MALFUNCTION	TEST or INSPECTION	CORRECTIVE ACTION
<b>1. Engine Troubleshooting.</b>		Refer to WP 0006 00.
<b>2. Engine Fails to Crank.</b>	Using accessory drive, attempt to rotate engine.	If engine cannot be rotated, internal damage is indicated. Remove engine (WP 0229 00).
<b>3. Engine Cranks, But Does Not Start.</b>	1. Inspect engine gear train for correct timing mark alignment.	Refer to TM 9-2815-225-34&P.
	2. Inspect engine gear train for damaged or missing gear teeth.	Refer to TM 9-2815-225-34&P.
<b>4. Engine Runs Erratically.</b>	1. Inspect engine gear train for correct timing mark alignment.	Refer to TM 9-2815-225-34&P.
	2. Inspect engine gear train for damaged or missing gear teeth.	Refer to TM 9-2815-225-34&P.
<b>5. High Oil Consumption.</b>	1. Clean and inspect engine for signs of external oil leaks.	If no oil leaks are identified, internal damage is indicated. Remove engine (WP 0229 00).
	2. Inspect rear of engine for signs of leaking oil.	Refer to TM 9-2815-225-34&P.
	3. Inspect front of engine for signs of leaking oil.	Refer to TM 9-2815-225-34&P.
	4. Inspect turbocharger for signs of leaking oil.	Refer to TM 9-2815-225-34&P.
	5. Inspect oil pan for signs of leaking oil.	Refer to TM 9-2815-225-34&P.

**END OF WORK PACKAGE**





---

**TRANSMISSION TROUBLESHOOTING**

**0225 00**

---

**THIS WORK PACKAGE COVERS**

Transmission Troubleshooting Procedures

---

**INITIAL SETUP**

**Maintenance Level**

Direct Support

**Tools and Special Tools**

Tool kit, general mechanic's (Item 102, WP 0313 00)

---

**Table 1. Transmission Troubleshooting Procedures.**

MALFUNCTION	TEST OR INSPECTION	CORRECTIVE ACTION
<p><b>1. Transmission Troubleshooting.</b></p>		<p>Refer to WP 0021 00.</p>

**END OF WORK PACKAGE**



THIS WORK PACKAGE COVERS

Steering System Troubleshooting Procedures

INITIAL SETUP

Maintenance Level

Direct Support

Tools and Special Tools - Continued

Tester, power steering (Item 98, WP 0313 00)

Tools and Special Tools

Tool kit, general mechanic's (Item 102, WP 0313 00)

Adapter kit, mechanical (Item 3, WP 0313 00)

Materials/Parts

Rag, wiping (Item 39, WP 0312 00)

Table 1. Steering System Troubleshooting Procedures .

MALFUNCTION	TEST or INSPECTION	CORRECTIVE ACTION
<p>1. No Recovery.</p>	<p>1. Disconnect lower steering column from steering gear and check steering column for binding.</p> <p>2. Check for sufficient pump pressure as follows:</p> <p>(a) Disconnect pressure hose from power steering pump.</p> <p>(b) Connect adapter hose from adapter kit to power steering pump.</p> <p>(c) Connect hose from dial end of power steering tester to adapter hose.</p> <p>(d) Connect hose from load valve end of power steering tester to pressure hose.</p> <p style="text-align: center;"><b>CAUTION</b></p> <p>Before performing step e, ensure load valve is completely open to prevent damage to flow/pressure valve.</p> <p>(e) With engine idling, rotate steering wheel to left and right for 5 minutes to warm power steering fluid.</p>	<p>1. Replace defective tilt steering column (WP 0266 00).</p> <p>2. Replace defective universal joint (WP 0157 00).</p>

Table 1. Steering System Troubleshooting Procedures - Continued.

MALFUNCTION	TEST or INSPECTION	CORRECTIVE ACTION
<p>1. No Recovery - Continued.</p>	<p style="text-align: center;"><b>CAUTION</b></p> <p>To prevent damage to power steering pump during performance of step f, do not allow load valve to be closed for more than 5 seconds.</p> <p>(f) With engine idling, close load valve and read pressure gage. Pressure must be 900 to 1000 psi (62.07 to 68.97 bars).</p> <p>3. Check for sufficient pump flow as follows:</p> <p>(a) Perform steps a through e of step 2.</p> <p style="text-align: center;"><b>WARNING</b></p> <p>Maximum flow rate is 7 gpm (26.5 liters/min). Flow rate in excess of 7 gpm (26.5 liters/min) will damage steering gear and could cause loss of steering and injury to personnel.</p> <p>(b) With engine idling, read flow meter. Rate of flow must be 7 gpm (26.5 liters/min).</p> <p>(c) With engine idling, close load valve until pressure gage indicates pump relief and pump relief pressure drops to 0. Immediately open load valve. Flow rate must return to 7 gpm (26.5 liters/min).</p> <p>(d) Run engine at 2100 rpm and fully close load valve until pressure gage indicates pump relief and flow rate drops to 0. Immediately open load valve. Flow rate must return to 7 gpm (26.5 liters/min).</p> <p>4. Check for defective teflon seals in steering control valve.</p> <p>5. Check for steering gear control valve sticking.</p>	<p>If pressure is less than 900 psi (62.07 bars), Replace power steering pump (WP 0264 00).</p> <p>Replace power steering pump (WP 0264 00).</p> <p>Replace power steering pump (WP 0264 00).</p> <p>Replace power steering pump (WP 0264 00).</p> <p>Replace steering gear (WP 0265 00).</p> <p>Replace steering gear (WP 0265 00).</p>
<p>2. External Oil Leaks from Steering Gear.</p>	<p style="text-align: center;"><b>NOTE</b></p> <p>External leakage is not acceptable from steering gear.</p>	

Table 1. Steering System Troubleshooting Procedures - Continued.

MALFUNCTION	TEST or INSPECTION	CORRECTIVE ACTION
<p><b>2. External Oil Leaks from Steering Gear - Continued.</b></p>	<p>1. Check for leak at rubber relief plug (on frame side of steering gear).</p> <p>2. Check for leak at shaft seals.</p>	<p>Replace steering gear (WP 0265 00).</p> <p>Replace steering gear (WP 0265 00).</p>
<p><b>3. Oversteer or Darting.</b></p>	<p>1. Disconnect lower steering column from steering gear and check steering column for binding.</p> <p>2. Disconnect steering gear pitman arm and check front end components for binding.</p>	<p>1. Replace defective tilt steering column (WP 0266 00).</p> <p>2. Replace defective universal joint (WP 0157 00).</p> <p>Replace defective components (WP 0158 00).</p>
<p><b>4. High Steering Effort in One Direction.</b></p>	<p>1. Check for sufficient pump pressure (Malfunction 1, step 2).</p> <p>2. Check for sufficient pump flow (Malfunction 1, step 3).</p> <p>3. Check for defective teflon seals in steering control valve.</p> <p>4. Check for steering gear control valve sticking.</p>	<p>If pressure is less than 900 psi (62.07 bars), replace power steering pump (WP 0264 00).</p> <p>Replace power steering pump (WP 0264 00).</p> <p>Replace steering gear (WP 0265 00).</p> <p>Replace steering gear (WP 0265 00).</p>
<p><b>5. High Steering Effort in Both Directions.</b></p>	<p>1. Check for sufficient pump pressure (Malfunction 1, step 2).</p> <p>2. Check for sufficient pump flow (Malfunction 1, step 3).</p> <p>3. Check for defective teflon seals in steering control valve.</p> <p>4. Check for steering gear control valve sticking.</p> <p>5. High steering effort in one direction.</p>	<p>If pressure is less than 900 psi (62.07 bars), replace power steering pump (WP 0264 00).</p> <p>Replace power steering pump (WP 0264 00).</p> <p>Replace steering gear (WP 0265 00).</p> <p>Replace steering gear (WP 0265 00).</p> <p>Replace steering gear (WP 0265 00).</p>

END OF WORK PACKAGE



**THIS WORK PACKAGE COVERS**

Preliminary Checks, Performance Tests, Safety Precautions, Air Conditioning System Components, Air Conditioning Troubleshooting

---

**INITIAL SETUP****Tools and Special Tools**

Tool kit, general mechanic's (Item 102, WP 0313 00)

---

**PRELIMINARY CHECKS**

Before testing the operation of the air conditioning system, make the following checks:

1. Ensure the refrigerant compressor's drive belt is not damaged and is correctly tensioned. Also check the compressor mountings for tightness.
2. Check for broken, burst or cut hoses; also check for loose fittings on all parts.
3. Check for road debris buildup on the condenser coil fins. Using air pressure and a whiskbroom or a soapy spray of water, carefully clean off the condenser; be careful not to bend the fins.
4. Check the color of the moisture indicator sight glass. If the color is a deep cobalt blue, the refrigerant charge is dry. If the indicator is not blue, the system is contaminated with moisture. Recover the refrigerant, evacuate the system, replace the receiver-dryer, and add a full refrigerant charge (WP 0297 00).
5. If there is not enough airflow, ensure leaves or other debris have not entered the fresh air ports under the windshield. If debris has entered, it could clog the fins of the evaporator core, and block airflow. Also, be sure that all ducts are connected to the dash louvers and that the air-control flaps in the heater housing are moving properly (this requires removal of the right and center dash panel).

**PERFORMANCE TESTS**

Following is a brief description of symptoms or conditions that could exist if something goes wrong with a refrigerant part.

1. **Receiver-Dryer.**
  - a. The receiver-dryer is normally at outside temperature. To the touch, the entire length of the unit should be the same temperature. If noticeable cool spots exist, replace receiver-dryer (WP 0303 00).
  - b. A blockage at the inlet of the unit will cause high head pressures; outlet blockages will cause low head pressures and little or no cooling.
  - c. If the moisture indicator is pink or white (showing that the system is wet), the receiver-dryer is saturated with moisture and must be replaced (WP 0303 00).
2. **Cooling System.**
  - a. Although they are not physically connected, there is a close tie between vehicle's air conditioner and cooling system. Poor air conditioner cooling can be the result of a problem in the cooling system.
  - b. If the cooling system does not work correctly, the heat of the engine will rise to abnormal levels. The added heat will transfer to the air conditioner, other underhood parts, and may make its way into the cab. The added heat makes it necessary for the air conditioner to work harder and, at the same time, it reduces the air conditioner's ability to cool down the air in the cab. Also, if the water regulating valve isn't closing all the way, heat will enter the cab, giving the impression that the air conditioning system is not working.

**PERFORMANCE TESTS - CONTINUED**

- c. Refer to WP 0009 00 to troubleshoot engine cooling system.
3. **Expansion Valve.**
    - a. Problems that start in the expansion valve show up as follows: when stuck closed, the evaporator coil and the expansion valve will be at outside temperature; when stuck open, both the coil and the valve will be extremely cold with frost or ice buildup.
    - b. Because the expansion valve channels are very small, blockages in the system tend to be found here (the valve is very sensitive to contamination). Usually, the contaminant is water; less than a drop of water is all it takes to make the valve inoperative. When water reaches the valve, the extreme cold that results from the pressure drop freezes the water, forming a block of ice in the valve. After the system shuts down and the valve warms up, the ice melts, and the valve operates again, only to freeze up when the moisture returns.
    - c. On-and-off operation of the expansion valve means that the receiver-dryer is not removing moisture from the system. These contaminants should cause the moisture indicator's element to turn white and then pink.
  4. **Refrigerant Compressor.**
    - a. Compressor problems usually show in one of four ways: abnormal noise; seizure; leakage; or low suction and discharge pressures.
    - b. Resonant compressor noises are not causes for alarm; irregular noise or rattles are likely to be caused by broken parts.
  5. **Evaporator.**
    - a. The evaporator coils are basically trouble-free when airflow over the fins is not blocked. External or, less often, internal blockages will cause low suction pressure as well as little or no cooling.
    - b. If a leak exists in the system, and it cannot be traced to other parts or fittings, suspect damage to one of the evaporator coils.
  6. **Condenser.**
    - a. The condenser is usually trouble-free. Normally, the temperature of the condenser outlet line is noticeably cooler than the inlet line. However, when road debris (such as leaves or dirt buildup) cakes up, airflow over the condenser fins is blocked; air is not able to absorb enough heat to turn the hot refrigerant gas into a liquid. High head pressures will result. In these cases, carefully clean off the outer surfaces of the condenser with compressed air or a soap and water solution; be careful not to bend the fins.
    - b. High head pressures will also occur if the condenser's tubing is abnormally bent, blocking the flow of refrigerant. Frost will appear at the point where the flow is restricted.
    - c. Less common internal blockages (bits of foreign material or metallic grit buildup) will stop the flow of refrigerant.
    - d. A quick test to check that poor system performance is caused by the condenser is to direct a spray of water onto the condenser while the system is running. If the air conditioner cools better because of the assist provided by the water, it is a sign that the condenser is not working.
    - e. When troubleshooting a suspected condenser problem, remember that the problem may be caused by the radiator transferring high levels of heat to the condenser. Refer to WP 0009 00 to troubleshoot the engine cooling system.
  7. **Thermostatic Switch.**
    - a. **IMPORTANT:** Before troubleshooting the thermostatic switch, check for a full charge of refrigerant in the system. The compressor will not operate, or will cycle too often, if there is not enough refrigerant in the system.
    - b. Quick or delayed cycling of the compressor may be caused by a thermostatic switch that is working, but is out of adjustment. If, after doing the tests below, the switch seems to be out of adjustment, replace it (WP 0214 00) (the thermostatic switch cannot be recalibrated).



**PERFORMANCE TESTS - CONTINUED**

- (1) Ensure the compressor clutch is operating correctly.
- (2) Expose the evaporator coil.
- (3) Start the engine. Place the air conditioner control at its coldest setting; turn on the air conditioner and the fan.
- (4) Place an accurate thermometer in contact with a tube on the evaporator coil. Ensure the thermometer is in good contact with the tube or you will get a wrong reading.

When the temperature drops below 31°F to 36°F (-1°C to 2°C), the compressor clutch should disengage and remain this way until the temperature rises to 39°F to 44°F (4°C to 7°C).

- (5) If the compressor did not engage when the temperature was above the accepted high range, do the following test:
  - (a) Connect a voltmeter or a test light from one of the terminals on the thermostatic switch to ground. Repeat this test with the other terminal on the switch.
  - (b) With the engine running and the air conditioner and blower on, both terminals will show voltage when the compressor should be engaged; one terminal will show voltage when the compressor should be disengaged.

If there is no voltage, there is a problem in the electrical system from the batteries to the thermostatic switch. Check all circuits for the cause, and repair or replace the wiring or parts.

In all other cases where the compressor is not engaging and disengaging properly, the thermostatic switch is the cause. Replace it with a new switch (WP 0214 00).

- (6) Shut down the engine and, to prevent accidental electric shock or shorting during dash assembling, disconnect the batteries.
- (7) Assemble the dash.

**8. Line Restrictions.**

- a. A restricted suction line causes low suction pressure at the compressor and little or no cooling. A restriction in a line between the compressor and the expansion valve can cause high discharge and low suction pressure, and insufficient cooling.
- b. Usually, areas of ice or frost buildup mean a blockage. Parts that often freeze up are probably corroded or inoperative and should be replaced. Parts (such as the expansion valve) that freeze up once in a while may do so because of moisture in the system, which will cause the moisture indicator's element to turn white or pink; if this happens, recover the refrigerant charge, evacuate/recycle the system refrigerant, replace the receiver-dryer, and install a new charge (WP 0297 00).

**SAFETY PRECAUTIONS**

1. Whenever repairs are made to any air conditioner parts that hold refrigerant, you must discharge, purge or flush (if contaminated), evacuate, charge, and leak test the system. In a good system, refrigerant lines are always under pressure and you should disconnect them only after the air conditioning system has been discharged to a refrigerant recovery unit through the service valves on the compressor (WP 0297 00).

**SAFETY PRECAUTIONS - CONTINUED****WARNING**

Use care to prevent refrigerant from touching your skin or eyes. Liquid refrigerant, when exposed to the air, quickly evaporates and will freeze skin or eye tissue. Serious injury or blindness may result if you come in contact with liquid refrigerant.

2. Refrigerants are safe when used under the right conditions. Always wear safety goggles and non-leather gloves while discharging, purging, flushing, evacuating, charging, and leak testing the system. Do not wear leather gloves; when refrigerant gas or liquid contacts leather, the leather will stick to your skin.
3. Refrigerant splashed in the eyes should first be treated with a few drops of sterile mineral oil in the eyes, then rinsed with a weak boric acid solution. Do not rub the eyes. Call a doctor right away.
4. Refrigerant splashed on the skin should be treated the same as for frostbite: gently pour cool water on the area, but do not rub the skin. Keep the skin warm with layers of soft, sterile cloth. Call a doctor right away.

**WARNING**

Do not work in an area where refrigerant may contact an open flame or any burning material, such as a cigarette. When it contacts extreme heat, refrigerant breaks down into poisonous phosgene gas which, if breathed, causes severe respiratory irritation. Do not breathe the fumes from an open flame leak detector.

5. Even though refrigerant does not burn, when it contacts extreme heat or flame, poisonous phosgene gas is created. This gas is also produced when an open flame leak detector is used. Phosgene fumes have an acrid (bitter) smell.
6. You must work in an area where there is a constant flow of fresh air when the system is discharged, flushed, charged, and leak tested using an open flame leak detector.
7. Changes in both federal and state laws will affect the way air conditioning systems are serviced. Under current federal laws, refrigerant must be recovered and recycled by all users to protect the environment, and not released into the atmosphere. Many service operations not directly involving the air conditioning system require the release of the refrigerant charge.
8. Because of its very low boiling point, refrigerant must be stored under pressure. To prevent the refrigerant cans from exploding, never expose them to temperatures higher than 125°F (52°C). Never leave refrigerant cans in the sun, and do not store them in sun-exposed areas where heat can build up, such as in gloveboxes, automobile trunks, etc.

SAFETY PRECAUTIONS - CONTINUED

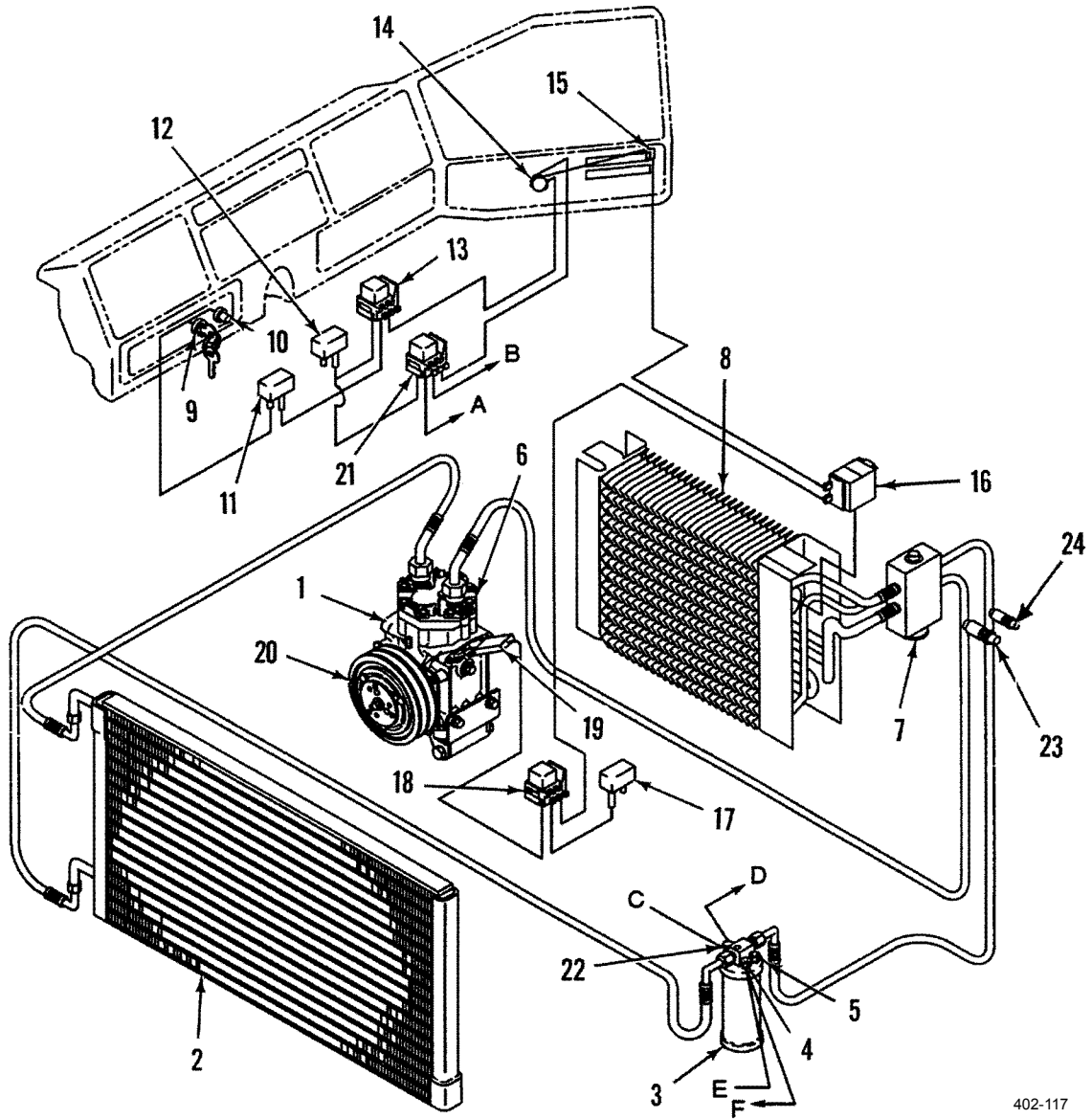

402-117

- |                                  |                                |                             |
|----------------------------------|--------------------------------|-----------------------------|
| A To resistor block              | D To engine fan thermal switch | 17 Circuit Breaker (15A)    |
| B To blower motor                | E From a/c clutch relay        | 18 A/C clutch Relay         |
| C From engine fan thermal switch | F To compressor clutch         | 19 Diode                    |
| 1 Compressor                     | 9 Ignition Switch              | 20 Compressor Clutch        |
| 2 Condenser                      | 10 Start Button                | 21 High-speed Relay         |
| 3 Receiver-dryer                 | 11 Circuit Breaker (10A)       | 22 Fan Cycling Switch       |
| 4 Binary Switch                  | 12 Circuit Breaker (30A)       | 23 Discharger Service Valve |
| 5 Moisture Indicator             | 13 Power Relay                 | 24 Suction Service Valve    |
| 6 High Pressure Relief Valve     | 14 Blower Switch               |                             |
| 7 Expansion Valve                | 15 "On-Off" Microswitch        |                             |
| 8 Evaporator                     | 16 Thermostatic Switch         |                             |

AIR CONDITIONING SYSTEM TROUBLESHOOTING LOGIC TREE

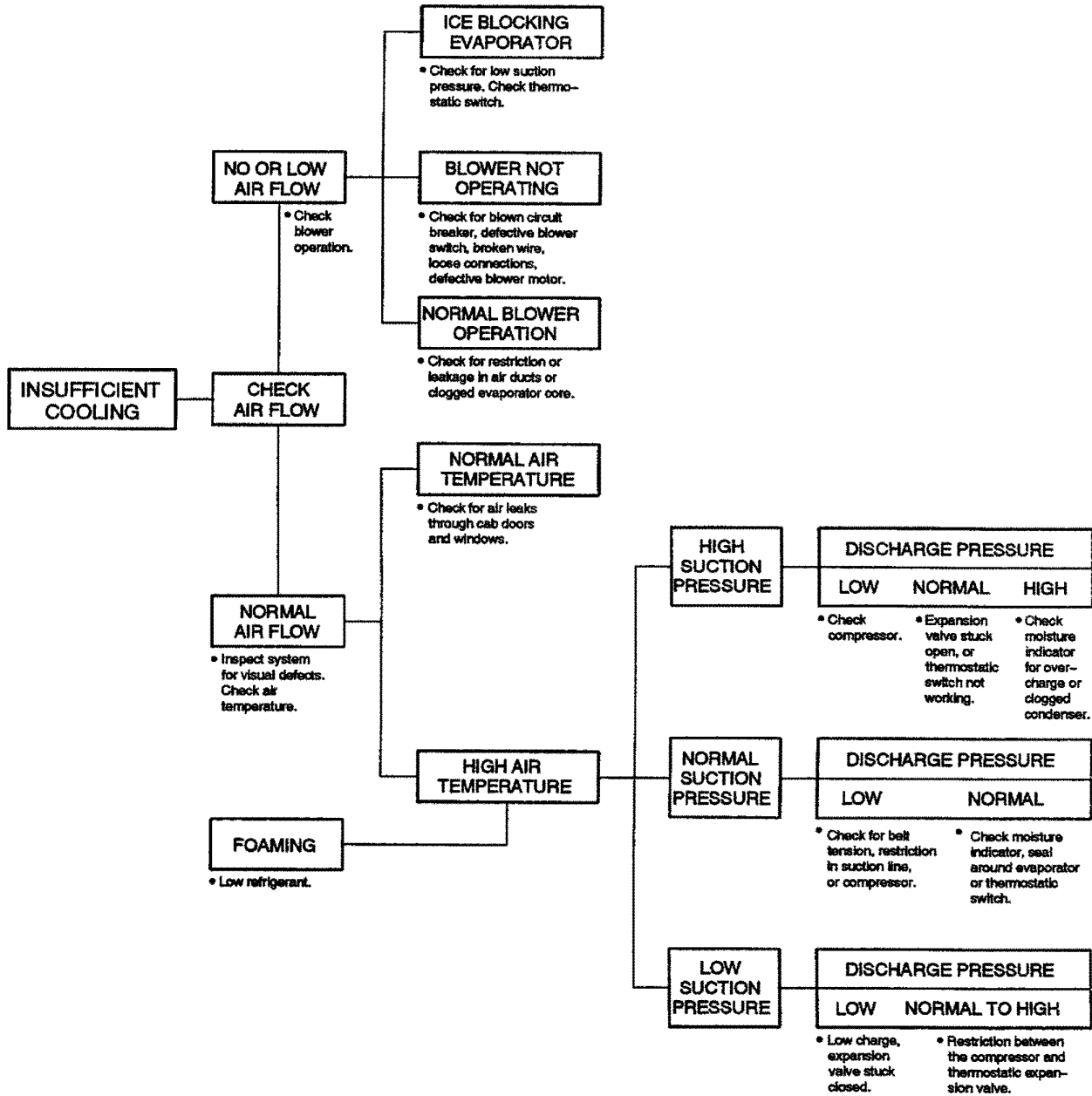

**AIR CONDITIONING SYSTEM TROUBLESHOOTING**

**Table 1. Problem - Warm Airflow When Air Conditioning Is On.**

Possible Cause	Remedy
There is no refrigerant charge in system.	Repair any leaks, evacuate system and add a full charge of refrigerant (WP 0297 00).
Moisture in system.	If moisture is in system, ice crystals may form at expansion valve, blocking the flow of refrigerant (off and on). Recover refrigerant charge (WP 0297 00), evacuate system, and add a full charge of refrigerant (WP 0297 00).

**Table 2. Problem - Low Evaporator Coil Outlet Pressure (Low Compressor Suction Pressure).**

Possible Cause	Remedy
The expansion valve is not working	Replace expansion valve (WP 0299 00).
There are restrictions in line to expansion valve.	Remove line restrictions.
There is an insufficient refrigerant charge in system.	Locate leak. Recover refrigerant charge (WP 0297 00) and add a full refrigerant charge (WP 0297 00).

**Table 3. Problem - High Compressor Discharge Pressure.**

Possible Cause	Remedy
There is an internal restriction in condenser. (Ice buildup on the condenser or a cool spot on the line from the condenser to the receiver-dryer).	Replace condenser (WP 0304 00).
Air is present in system.	Repair any leaks, evacuate system and add a full charge of refrigerant (WP 0297 00).
Restriction in compressor discharge line.	Repair or replace line (WP 0305 00).

**Table 4. Problem - Evaporator Outlet Air Temperature Increases as Compressor Discharge Pressure Drops.**

Possible Cause	Remedy
The expansion valve setting is too low.	Replace expansion valve (WP 0299 00). Add a full charge of refrigerant (WP 0297 00).

**AIR CONDITIONING SYSTEM TROUBLESHOOTING - CONTINUED**

**Table 5. Problem - Compressor Operates Too Often or Continuously.**

Possible Cause	Remedy
There is too little refrigerant in system.	Repair any leaks (WP 0305 00) and add a full charge of refrigerant (WP 0297 00).
There is a restriction in refrigerant system.	Remove restriction from line.

**Table 6. Problem - Quick or Delayed Cycling of Compressor.**

Possible Cause	Remedy
Loss of refrigerant is causing a delayed cycling of the compressor.	Add a full charge of refrigerant (WP 0297 00).

**END OF WORK PACKAGE**

---

**POWER PACK REPLACEMENT**

**0228 00**

---

**THIS WORK PACKAGE COVERS**

Removal, Installation

---

**INITIAL SETUP**

**Maintenance Level**

Direct Support

**Personnel Required**

Two

**Tools and Special Tools**

Tool kit, general mechanic's (Item 102, WP 0313 00)

Spreader, sling (Item 93, WP 0313 00)

**References**

TM 9-2815-225-34 & P

---

**REMOVAL**

Refer to TM 9-2815-225 - 34&P, page 3-6.40 Change 1.

**INSTALLATION**

Refer to TM 9-2815-225 - 34&P, page 3-6.88 Change 1.

**END OF WORK PACKAGE**





---

**ENGINE/TRANSMISSION REPLACEMENT**

---

**0229 00****THIS WORK PACKAGE COVERS**Removal, Installation

---

**INITIAL SETUP****Maintenance Level**

Direct Support

**Tools and Special Tools**

Tool kit, general mechanic's (Item 102, WP 0313 00)

Barring tool, engine (Item 5, WP 0313 00)

Lift, transmission (Item 56, WP 0313 00)

Spreader, sling (Item 93, WP 0313 00)

Wrench, torque, 15-75 lb-ft (Item 110, WP 0313 00)

**Tools and Special Tools - Continued**

Wrench, torque 50-250 lb-ft (Item 111, WP 0313 00)

**Personnel Required**

Two

**References**

TM 9-2815-225-34&amp;P

**Equipment Condition**Power pack removed (WP 0228 00)

---

**REMOVAL**

Refer to TM 9-2815-225-34 &amp; P, page 3-6.74 Change 1.

**INSTALLATION**

Refer to TM 9-2815-225-34 &amp; P, page 3-6.82 Change 1.

**END OF WORK PACKAGE**



---

**ENGINE MOUNTS REPLACEMENT**

**0230 00**

---

**THIS WORK PACKAGE COVERS**

Removal, Installation

---

**INITIAL SETUP**

**Maintenance Level**

Direct Support

**Tools and Special Tools**

Tool kit, general mechanic's (Item 102, WP 0313 00)

Jack, hydraulic (Item 52, WP 0313 00)

**Tools and Special Tools - Continued**

Trestle (Item 105, WP 0313 00)

**Equipment Condition**

Parking brake applied (TM 9-2320-303-10)

Air brake system drained (TM 9-2320-303-10)

**Personnel Required**

Two

---

**NOTE**

There are two rubber isolators for each of the three engine mounts. Both isolators must be replaced if one is defective.

**REMOVAL**

1. Remove four screws, washers, and fan shroud from radiator.

**NOTE**

Perform steps 2 through 5 to remove isolators at FRONT engine mount.

2. Attach chain to lifting eye at front of engine and attach other end of chain to suitable lifting device. Lift chain to remove slack.
3. Remove two nuts (1), four washers (2), two bolts (8), and adapter (3).

**CAUTION**

Lift engine only enough to remove isolators. Check clearance above engine to avoid damaging any component.

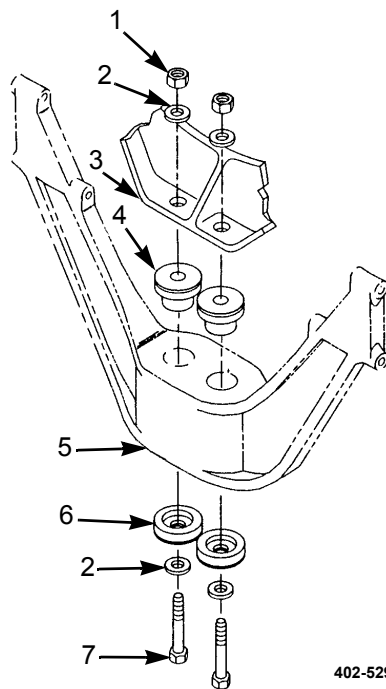

4. Lift front of engine and support front of engine with engine stands.
5. Remove two lower isolators (6) and two upper isolators (4) from front engine mount (5).

**NOTE**

Perform steps 6 through 11 to remove isolators at either of two REAR engine mounts.

6. Place engine jack at rear of engine and raise jack to support engine.
7. Loosen two nuts at engine mount opposite engine mount to be removed.
8. Remove two nuts (16), four washers (15), two washers (9), two bolts (8), and adapter (10).

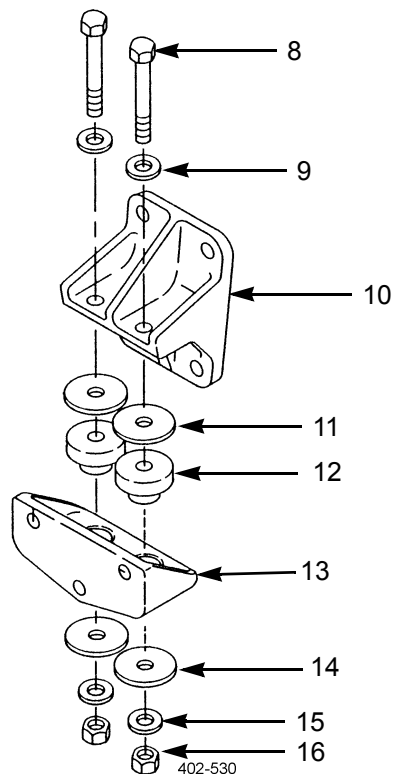
**REMOVAL - CONTINUED****CAUTION**

Lift engine only enough to remove washers and isolators. Check clearance above engine to avoid damaging any component.

9. Lift rear of engine and support rear of engine with engine stands.
10. Remove two washers (11), two washers (14), and isolators (12) from rear engine mount (13).
11. Repeat steps 8 and 10 for opposite engine mount, if necessary.

**INSTALLATION****NOTE**

Perform steps 1 through 3 to install isolators at REAR engine mounts.

1. Install two isolators (12), two washers (14), and washers (11) to rear engine mount (13) and to opposite engine mount, if removed.
2. Lower rear of engine and install adapter (10), two bolts (8), two washers (9), four washers (15), and two nuts (16).
3. Remove engine stands and engine jack. Tighten nuts to 160 lb-ft. (216 Nm).

**NOTE**

Perform steps 4 through 8 to install isolators at FRONT engine mount.

4. Loosely install two upper isolators (4), two lower isolators (6), and adapter (3) to front engine mount (5) with two bolts (7), four washers (2), and two nuts (1).
5. Remove engine stands from front of engine and lower engine.
6. Tighten nuts (1) to 241 lb-ft. (327 Nm).

---

**ENGINE MOUNTS REPLACEMENT - CONTINUED**

---

**0230 00**

***INSTALLATION - CONTINUED***

7. Remove chain from lifting eye of engine.
8. Install fan shroud to radiator with four washers and screws.

**END OF WORK PACKAGE**

---

**RADIATOR REPAIR**

**0231 00**

---

**THIS WORK PACKAGE COVERS**

Disassembly, Inspection, Repair, Assembly

---

**INITIAL SETUP**

**Maintenance Level**

Direct Support

**Tools and Special Tools**

Tool kit, general mechanic's (Item 102, WP 0313 00)

Shop equipment, automotive (Item 81, WP 0313 00)

**References**

TM 750-254

**Materials/Parts**

Gasket (P/N 05-12289-000) (2)

**Equipment Condition**

Radiator removed (WP 0044 00)

---

**REMOVAL**

1. Remove two nuts (15), two clamps (17), hose (23), and radiator cap (27).
2. Remove nut (26), clamp (25), two clamps (2), and hose (24).
3. Remove two nuts (1) and expansion tank (3) from radiator (4).
4. Remove 17 nuts (20), bolting bar (7), 20 screws (22), and top channel (21).
5. Remove 17 nuts (9), bolting bar (16), 20 screws (13), and bottom channel (14).
6. Remove 40 nuts (19), 40 screws (12), four bolting plates (5), four header bars (11), outlet tank (18), inlet tank (8), and two radiator gaskets (6). Discard gaskets.
7. Remove drain plug (10) from inlet tank (8).

**INSPECTION**

1. Inspect all parts for wear or damage.
2. Pressure test radiator at 15.0 psi (103.4 kPa) for leaks.

**REPAIR**

1. If repair is required, no more than 12 tubes can be blocked off.
2. Refer to TM 750-254 for additional information on cooling system repair.

**ASSEMBLY**

1. Install two new radiator gaskets (6), inlet tank (8), outlet tank (18), four header bars (11), four bolting plates (5), 40 screws (12), and 40 nuts (19).
2. Install bottom channel (14), 20 screws (13), bolting bar (16), and 17 nuts (9).
3. Install top channel (21), 20 screws (22), bolting bar (7), and 17 nuts (20).
4. Install expansion tank (3) and two nuts (1).
5. Install hose (24), two clamps (2), clamp (25), and nut (26) on radiator (4).
6. Install radiator cap (27), hose (23), two clamps (17), and two nuts (15).
7. Install drain plug (10) in inlet tank (8).
8. Replace radiator (WP 0044 00).



ASSEMBLY - CONTINUED

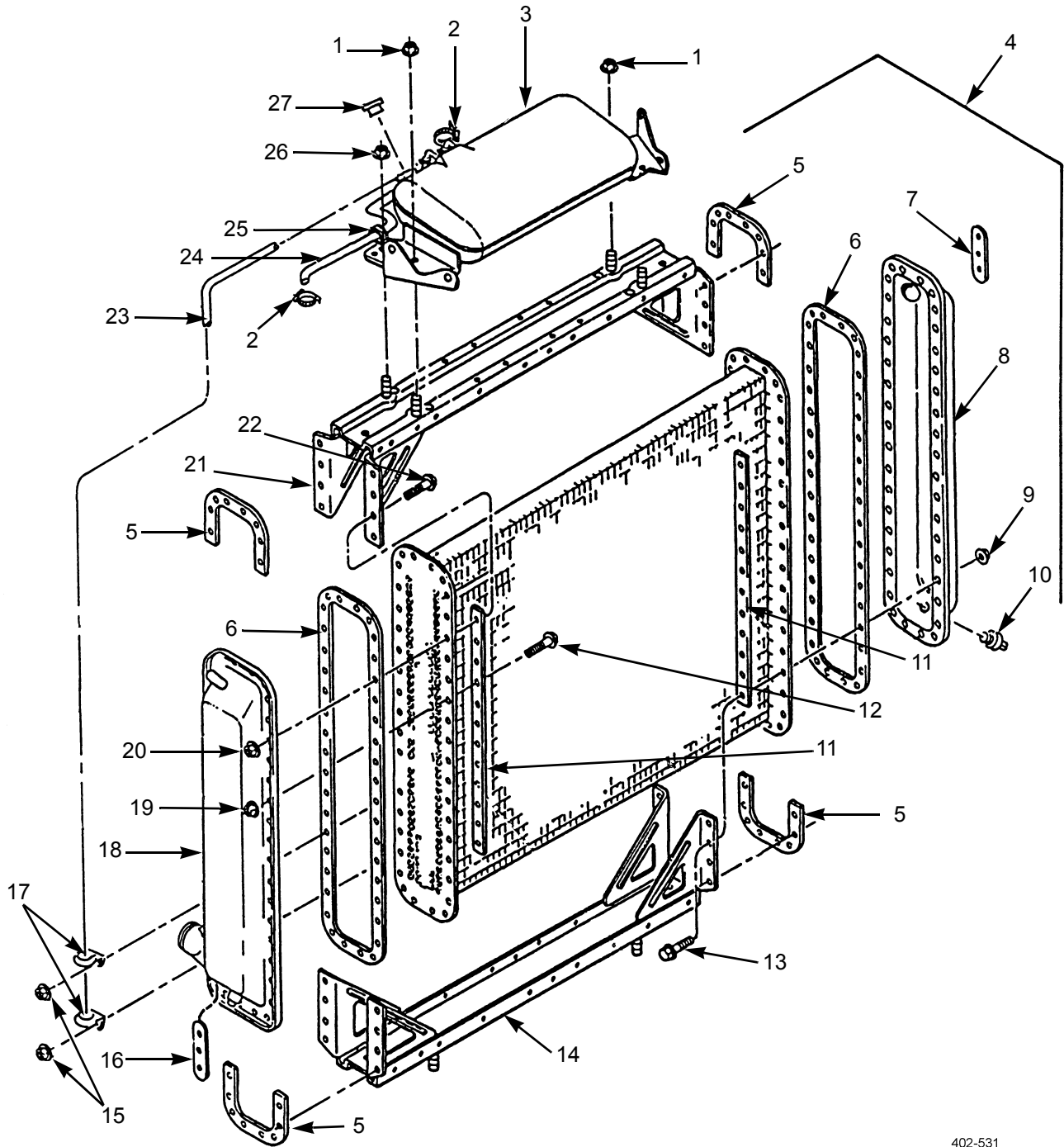

402-531

END OF WORK PACKAGE



**FAN CLUTCH REPAIR**

**0232 00**

**THIS WORK PACKAGE COVERS**

Disassembly, Assembly

**INITIAL SETUP**

**Maintenance Level**

Direct Support

**Materials/Parts**

Kit, repair (P/N 1033-07781-01)

**Tools and Special Tools**

Tool kit, general mechanic's (Item 102, WP 0313 00)

**Equipment Condition**

Fan clutch removed (WP 0049 00)

Clamp, C (2) (Item 11, WP 0313 00)

**DISASSEMBLY**

1. Remove nut (5), tab washer (6), cylinder (4), seal (3), packing (2), and dust seal (1) from clutch assembly (7). Discard nut, tab washer, seal, packing, and dust seal.

**WARNING**

Housing is under spring pressure. Use suitable "C" clamps to hold housing and shaft assembly in place while removing cylinder. Failure to do so could result in injury to personnel.

2. Install two "C" clamps on opposite sides of clutch assembly (7).

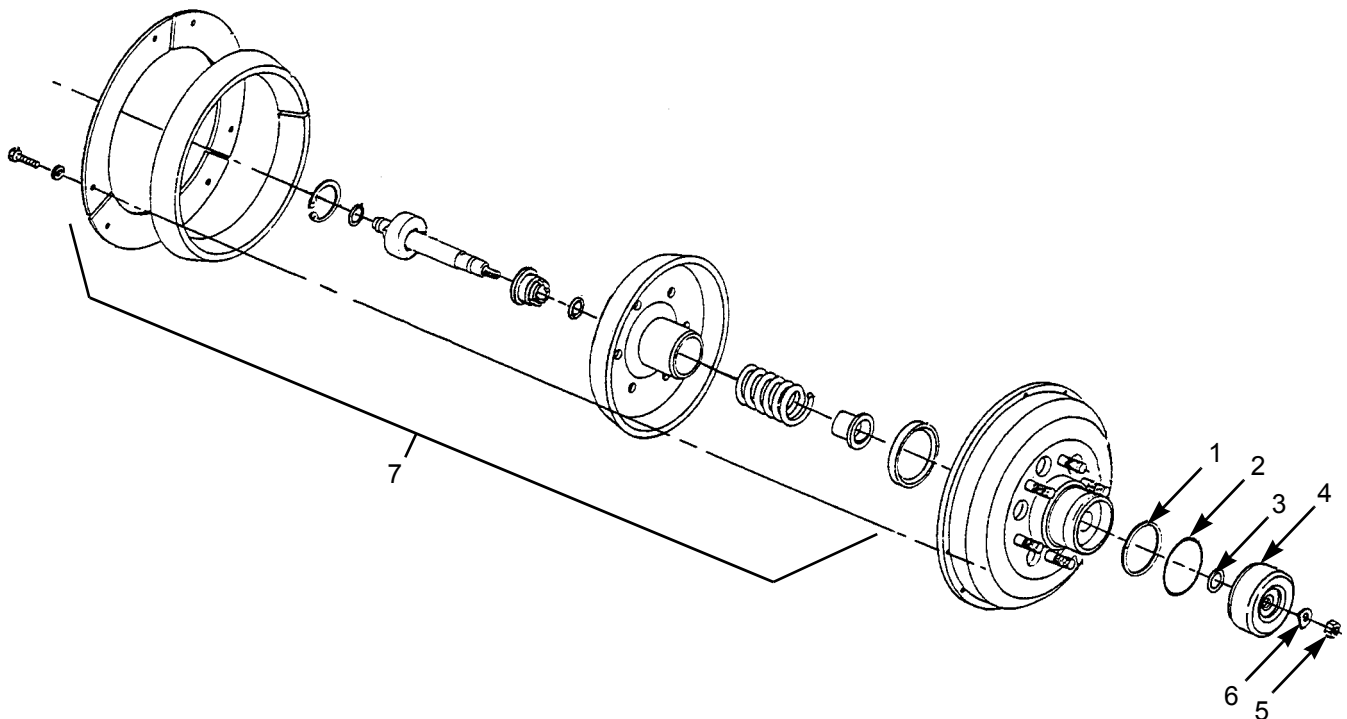

402-532

**FAN CLUTCH REPAIR - CONTINUED****0232 00****DISASSEMBLY - CONTINUED**

3. Remove six screws (22), lockwashers (21), three retaining plates (8), and lining (9) from shaft assembly (15). Discard screws, lockwashers, and lining.
4. Release "C" clamps slowly to relieve spring tension and remove housing (19), seal (18), end cap (17), and spring (16) from shaft assembly (15). Discard seal and spring.
5. Remove retaining ring (10) and piston assembly (12).
6. Remove two packings (11 and 14) and spring carrier (13) from piston. Discard packings.
7. If damaged, remove and discard studs (20) from housing (19).

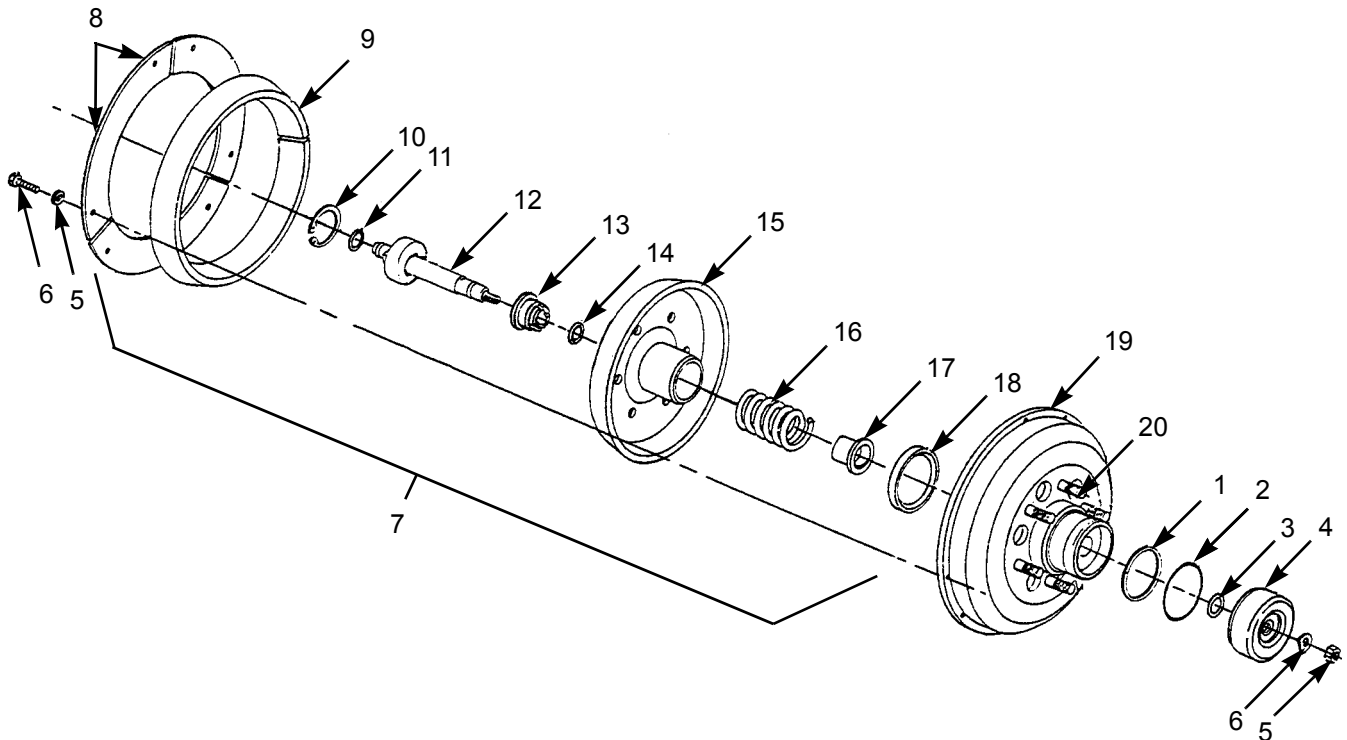

402-532

**ASSEMBLY**

1. If removed, install new studs (20) in housing (19).
2. Install two new packings (11 and 14) and spring carrier (13) to piston (12).
3. Install piston assembly (12) and retaining ring (10).
4. Install new spring (16), end cap (17), new seal (18), and housing (19) on shaft assembly (15).
5. Compress housing (19) and shaft assembly (15) using two "C" clamps and install new lining (9), three retaining plates (8), six new lockwashers (21), and new screws (22) in shaft assembly.
6. Remove two "C" clamps from opposite sides of clutch assembly (7).
7. Install new dust seal (1), new packing (2), new seal (3), cylinder (4), new tab washer (6), and new nut (5) on clutch assembly (7).
8. Install fan clutch (WP 0049 00).

**END OF WORK PACKAGE**

**ALTERNATOR REPAIR**

**0233 00**

**THIS WORK PACKAGE COVERS**

Disassembly, Testing, Assembly

**INITIAL SETUP**

**Maintenance Level**

Direct Support

**Tools and Special Tools**

- Tool kit, general mechanic's (Item 102, WP 0313 00)
- Shop equipment, automotive (Item 82, WP 0313 00)
- Caps, vise jaw (Item 10, WP 0313 00)
- Dial indicator set (Item 18, WP 0313 00)
- Multimeter (Item 59, WP 0313 00)
- Soldering gun (Item 90, WP 0313 00)
- Vise, machinist's (Item 106, WP 0313 00)

**Tools and Special Tools - Continued**

Wrench, torque, 50-250 lb-ft (Item 111, WP 0313 00)

**Materials/Parts**

- Cloth, abrasive (Item 10, WP 0312 00)
- Compound, sealing (Item 15, WP 0312 00)
- Solder (Item 40, WP 0312 00)
- Gasket (P/N R042097706)
- Seal (P/N 79405)
- Washer, lock (P/N Z095002434) (2)

**Equipment Condition**

Alternator and voltage regulator removed (WP 0058 00)

**DISASSEMBLY**

1. Remove two nuts (1 and 12), two washers (2 and 13), nut (3), and holder assembly (11) from alternator.
2. Remove plug (6), four screws (7), regulator (8), and gasket (9). Discard gasket.
3. Remove two nuts (4) and four washers (5) from regulator (8).
4. Disconnect brush (10) from holder assembly (11).

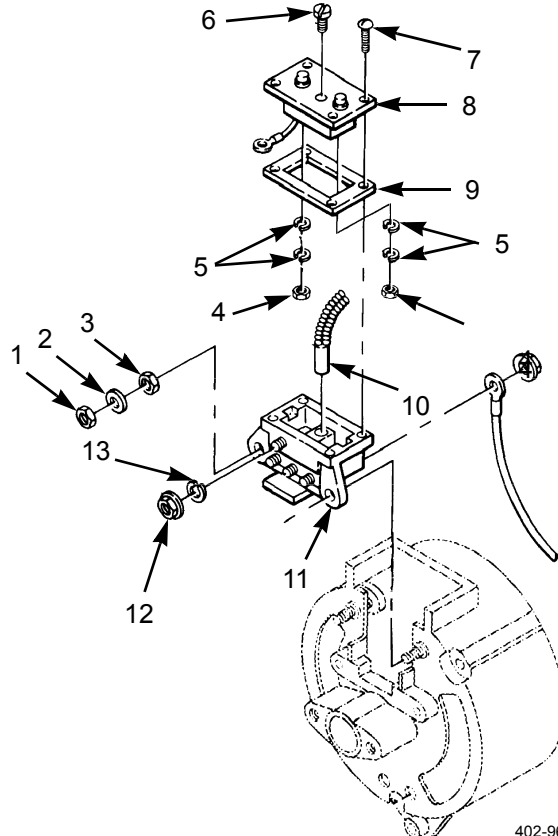

402-961

***DISASSEMBLY - CONTINUED***

5. Remove three screws (36), three washers (35), and housing (28).
6. Remove nut (25), fan holder (26), and washer (27) from housing (28).
7. Remove rotor (32) from housing (28).
8. Remove keyway (31) from rotor (32).
9. Remove four screws (34), retaining plate (30), and bearing (29) from housing (28).
10. Remove roller bearing (18) and ring assembly (33) from rotor (32).
11. Remove screw (6), bushing insulator (5), and sleeve bushing (4) from rectifier (3).
12. Remove screw (8) and electrical lead (7).
13. Remove screw (9), washer (10), washer (11), washer (12), sleeve bushing (2), and rectifier (3).
14. Remove bolt (16), bushing insulator (22), and sleeve bushing (21).
15. Remove screw (8) and electrical lead (24).
16. Remove screw (9), washer (10), washer (11), washer (12), sleeve bushing (2), and rectifier (23).
17. Remove stator (14) from housing (17).
18. Remove three screws (8), three nuts (20), clamp (15), and capacitor (13) from housing (17).
19. Remove cap (1) and sleeve bushing (19) from housing (17).

DISASSEMBLY - CONTINUED

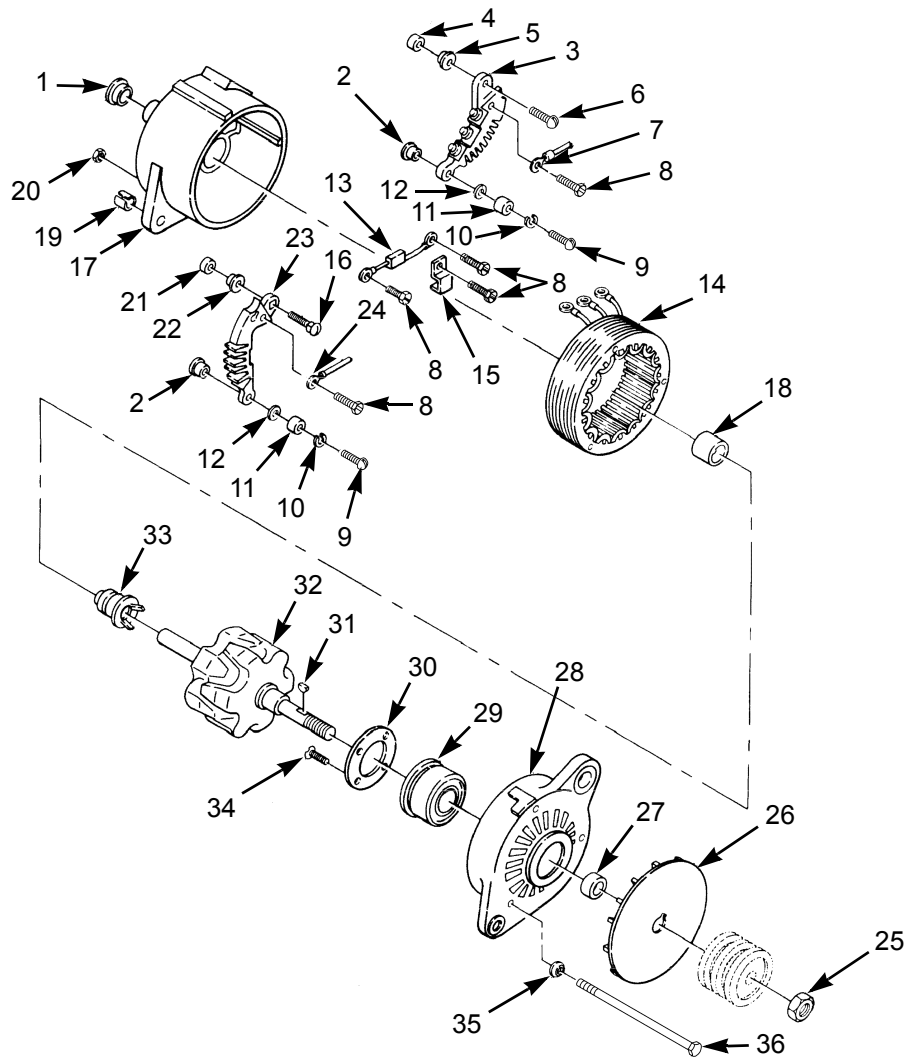

402-952G

**TESTING**

1. Test positive rectifier (23) as follows:
  - a. Connect positive lead of diode tester to positive rectifier (23). Touch negative lead to each of three diodes. High resistance should be indicated. If any of three diodes show low resistance, replace positive rectifier.
  - b. Reverse test leads so that negative lead is connected to positive rectifier (23). Touch positive lead to each of three diodes. Low resistance should be indicated. If any of three diodes show high resistance, replace positive rectifier.
2. Test negative rectifier (3) as follows:
  - a. Connect negative lead of diode tester to negative rectifier (3). Touch positive lead to each of three diodes. High resistance should be indicated. If any of three diodes show low resistance, replace negative rectifier.
  - b. Reverse test leads so that positive lead is connected to negative rectifier (3). Touch positive lead to each of three diodes. Low resistance should be indicated. If any of three diodes show high resistance, replace negative rectifier.

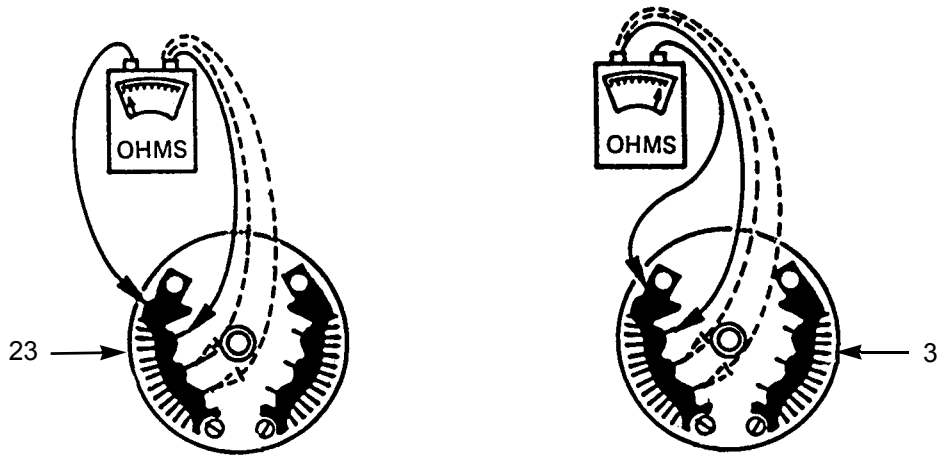

402-554

3. Check capacitor (13) using ohmmeter with positive and negative leads connected to terminals. If resistance reading is low, replace capacitor.

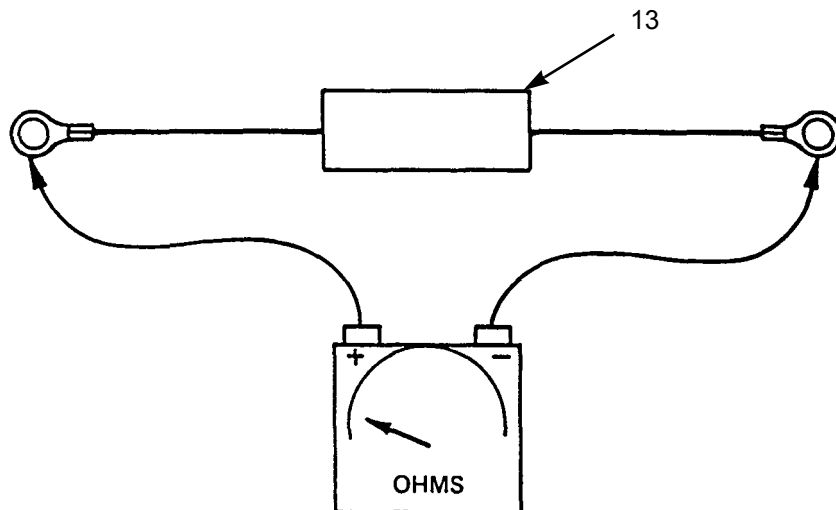

402-555



**TESTING - CONTINUED**

4. Test rotor assembly (32) as follows:
  - a. With ohmmeter connected between nut (37) and either of two slip rings (33), no reading should be obtained. If any reading is obtained, rotor coil (38) is grounded and rotor assembly (32) must be disassembled to repair short.
  - b. Check rotor coil (38) resistance by connecting ohmmeter across both slip rings (33). Resistance should be 9.6-10.4 ohms. If resistance is outside limits, replace rotor coil.

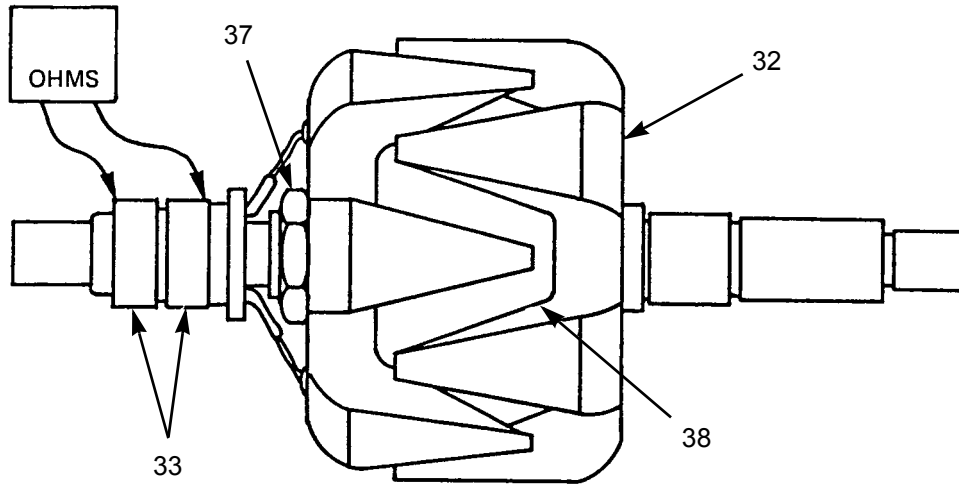

402-556

5. Test stator (14) as follows:
  - a. Connect one ohmmeter lead to bare metal surface on stator lamination (40). Connect other lead to each of three stator leads (39) terminals. High resistance reading should be obtained each time. If there is no reading or ohmmeter reads zero, replace stator.

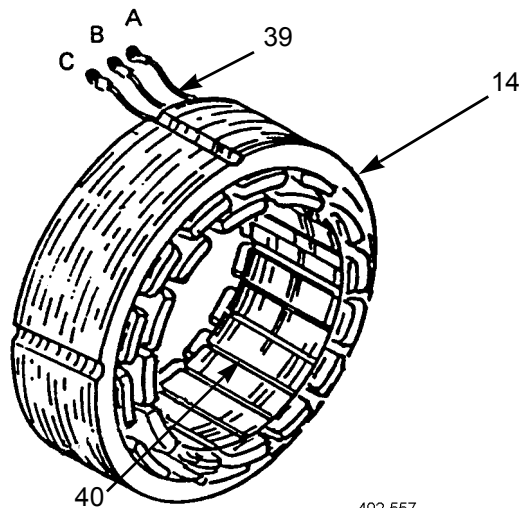

402-557

- b. Connect ohmmeter leads to stator leads (39) terminals as follows and note each reading:
      - (1) A and B
      - (2) A and C
      - (3) B and C
    - c. Each measurement in step b should be approximately equal. If difference is great between any two readings, replace stator (14).

**ASSEMBLY**

1. Install cap (1) and sleeve bushing (19) into housing (17)
2. Install capacitor (13), clamp (15), three screws (8), and three nuts (20) into housing (17).
3. Install stator (14) into housing (17).
4. Install rectifier (23), sleeve bushing (2), washer (12), washer (11), washer (10), and screw (9).
5. Install electrical lead (24) and screw (8).
6. Install sleeve bushing (21), bushing insulator (22), and bolt (16).
7. Install rectifier (3), sleeve bushing (2), washer (12), washer (11), washer (10), and screw (9).
8. Install electrical lead (7) and screw (8).
9. Install sleeve bushing (4), bushing insulator (5), and screw (6).
10. Install ring assembly (33) and roller bearing (18) onto rotor (32).
11. Install bearing (29), retaining plate (30), and four screws (34) into housing (28).
12. Install keyway (31) onto rotor (32).
13. Install rotor (32) into housing (28).
14. Install nut (25), fan holder (26), and washer (27) into housing (28).
15. Install three screws (36), three washers (35), and housing (28).

ASSEMBLY - CONTINUED

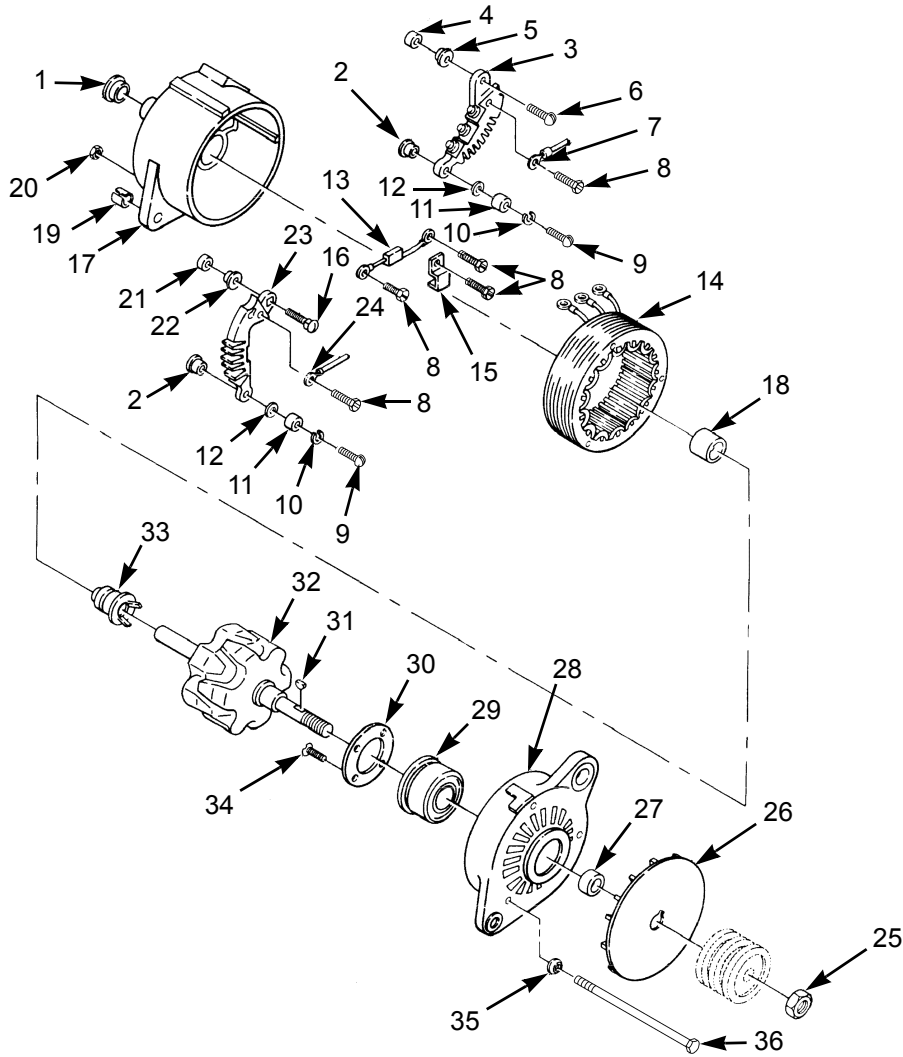

402-952G

**ASSEMBLY - CONTINUED**

16. Connect brush (10) to holder assembly (11).
17. Install two nuts (4) and four washers (5) on regulator (8).
18. Install new gasket (9), regulator (8), four screws (7), and plug (6).
19. Install holder assembly (11), nut (3), two washers (2 and 13), and two nuts (1 and 12) on alternator.

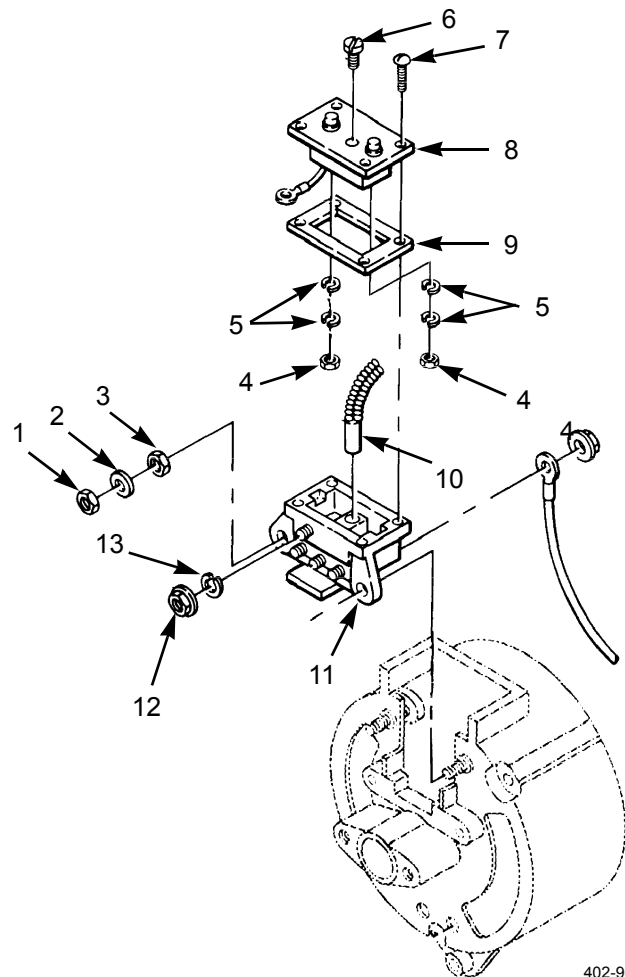

402-961

**END OF WORK PACKAGE**

**STARTER SOLENOID REPLACEMENT**

**0234 00**

**THIS WORK PACKAGE COVERS**

Removal, Installation

**INITIAL SETUP**

**Maintenance Level**

Direct Support

**Tools and Special Tools**

Tool kit, general mechanic's (Item 102, WP 0313 00)

Caps, vise jaw (Item 10, WP 0313 00)

Vise, machinist's (Item 106, WP 0313 00)

**Tools and Special Tools - Continued**

Wrench, torque, 15-75 lb-ft (Item 110, WP 0313 00)

**Materials/Parts**

Adhesive, silicone (Item 5, WP 0312 00)

**Equipment Condition**

Starter removed (WP 0060 00)

**REMOVAL**

1. Remove nut (1), lockwasher (2), and wire (3) from starter solenoid (5).
2. Remove nut (13) from starter solenoid (5).

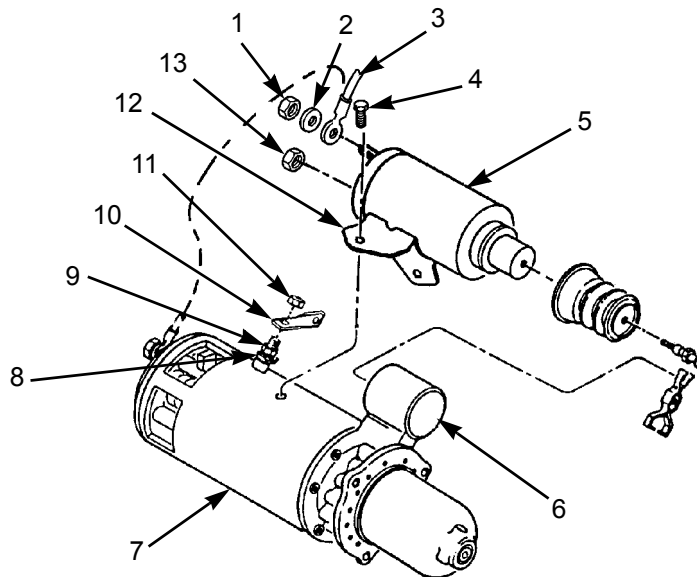

402-560

3. Hold nut (8) on starter motor (7) and remove nut (11) and jumper (10) from stud (9).
4. Remove two screws (4).
5. Pull starter solenoid (5) away from housing (6) and rotate so that mounting bracket (12) faces away from starter motor (7).

**STARTER SOLENOID REPLACEMENT - CONTINUED****0234 00****REMOVAL - CONTINUED**

- Remove spool (16) from shift fork (17).

**NOTE**

It may be necessary to use a soft-jawed vise to hold solenoid plunger for removal of spool.

- Remove spool (16) and boot (15) from solenoid plunger (14).

**INSTALLATION**

- Install boot (15) and spool (16) on solenoid plunger (14).
- Rotate starter solenoid (5) so that mounting bracket (12) faces away from starter motor (7).
- Install spool (16) in shift fork (17).
- Rotate starter solenoid (5) to mounting position and press flush with housing (6).
- Apply silicone adhesive to threads and install two screws (4).
- Install jumper (10) on stud (9).
- Apply silicone adhesive to last  $\frac{1}{4}$  in (6.4 mm) of threads on stud (9). Hold nut (8) and install nut (11). Tighten nut to 21-29 lb-ft (28-39 Nm).
- Install nut (13) on starter solenoid (5). Tighten nut to 18-22 lb-ft (24-30 Nm).
- Install wire (3), lockwasher (2), and nut (1) on starter solenoid (5).

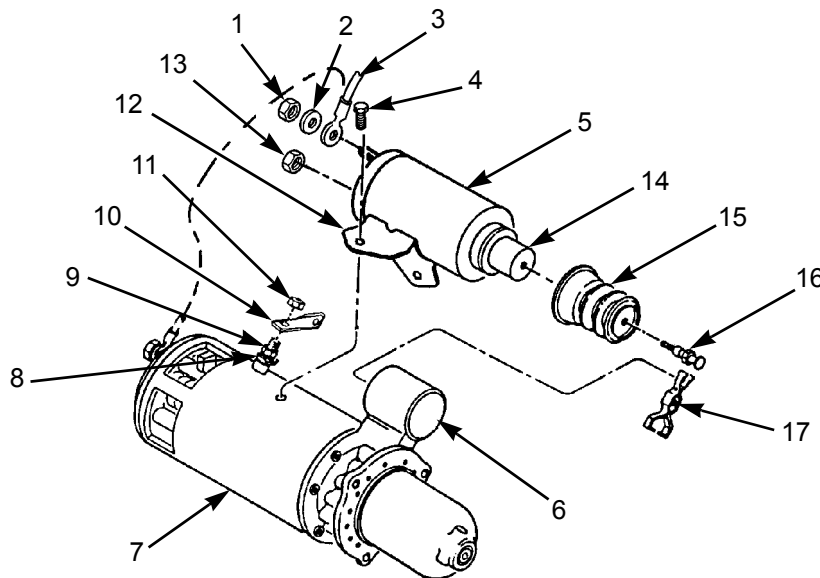

402-560

- Install starter (WP 0060 00).

**END OF WORK PACKAGE**

**THIS WORK PACKAGE COVERS**

Disassembly, Assembly

**INITIAL SETUP**

**Maintenance Level**

Direct Support

**Tools and Special Tools**

Tool kit, general mechanic's (Item 102, WP 0313 00)

Shop equipment, automotive (Item 82, WP 0313 00)

**Materials/Parts**

Adhesive, silicone (Item 5, WP 0312 00)

Packing (P/N 75784)

**Materials/Parts - Continued**

Packing (P/N 75783) (2)

Packing (P/N 74980)

Packing (P/N Z053071038) (2)

Seal (P/N 97799)

Washer, lock (P/N CBM21389) (4)

Washer, lock (P/N Z095002434) (9)

**Equipment Condition**

Starter solenoid removed (WP 0234 00)

**DISASSEMBLY**

1. Remove two nuts (2), screws (1), and brush opening band (3).

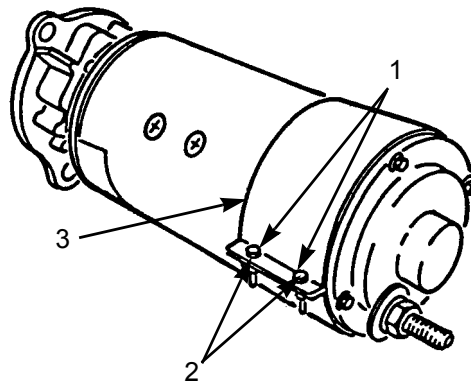

402-561

**DISASSEMBLY - CONTINUED****CAUTION**

Do not pull brush leads until spring tension is relieved to prevent damage to equipment.

2. Remove eight screws (7) and four lock plates (6).
3. Pull two springs (5) upward and remove eight brushes (4).

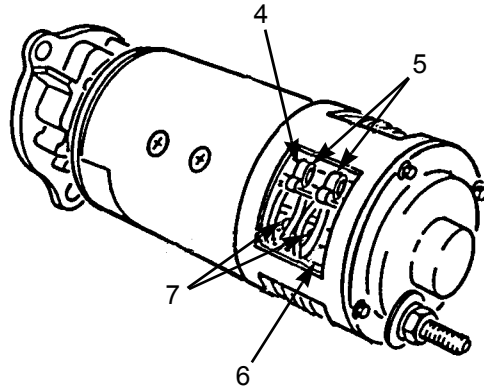

402-562

**NOTE**

Mark commutator housing and field ring prior to removing commutator housing to aid in installation.

4. Remove four screws (34), lockwashers (33), commutator housing (12), insulation washer (29), and washer (28) from field ring (26). Discard lockwashers.
5. Remove four screws (25), lockwashers (24), washers (23), eight insulation washers (21), and four insulation bushings (22). Discard lockwashers.
6. Remove four brush holders (31), insulation washers (19), and ground jumper (30) from commutator housing (12).
7. Remove nut (8), four washers (9), insulator (10), and packing (11) from ground stud (20). Discard packing.
8. Remove ground stud (20) from commutator housing (12).
9. Remove packing (16), insulation washer (17), and washer (18) from ground stud (20). Discard packing.
10. If damaged, remove bushing (15) from commutator housing (12).
11. Remove packing (27), pipe plug (14), and felt wick (13) from commutator housing (12). Discard packing.
12. If damaged, remove bushing (32) from commutator housing (12).



DISASSEMBLY - CONTINUED

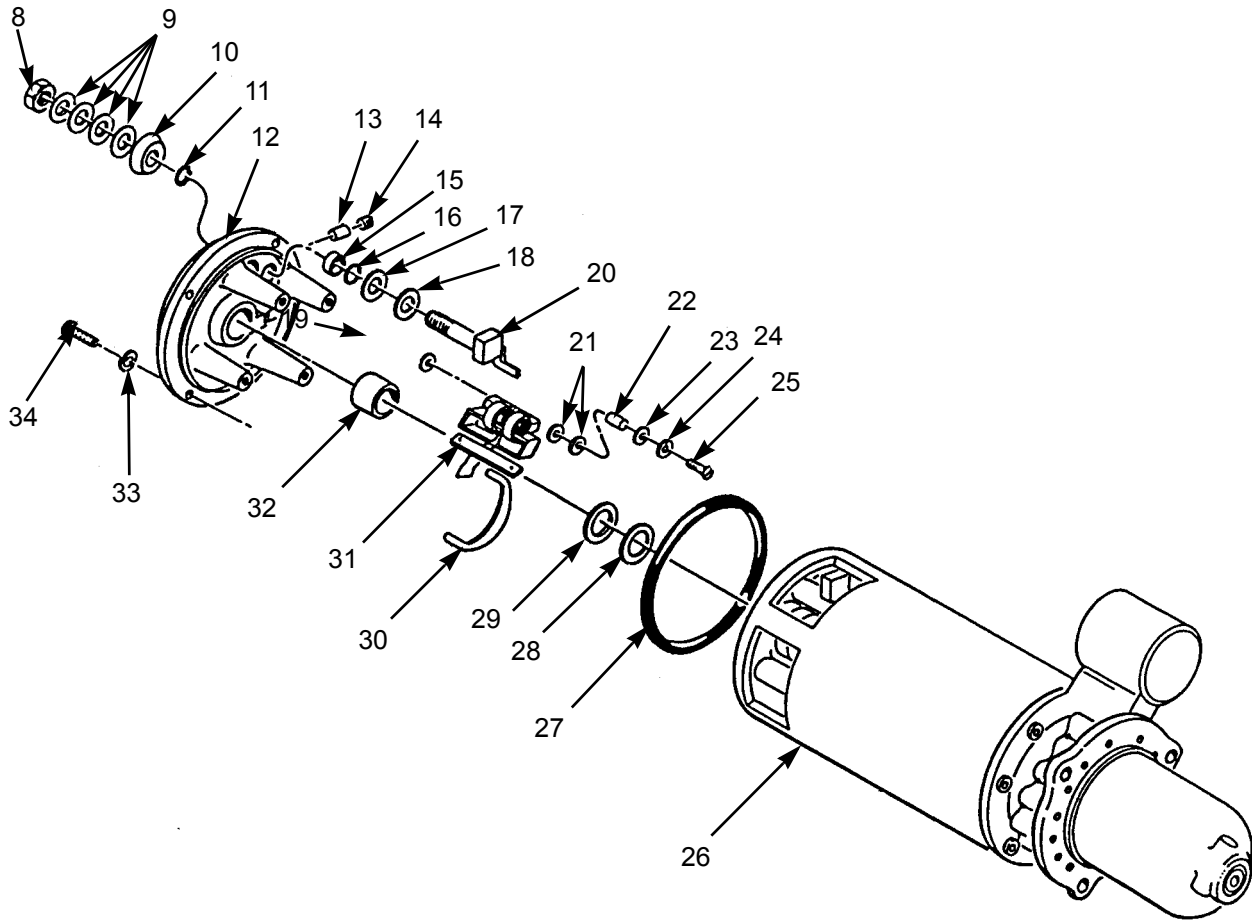

402-563

**DISASSEMBLY - CONTINUED****NOTE**

Mark nose housing and shift housing prior to removing nose housing to aid in installation.

13. Remove six screws (37), nose housing (36), packing (42), and washer (43) from shift housing (35). Discard packing.

**NOTE**

Perform step 14 only if components are damaged.

14. Remove bushing (38), plug (39), felt wick (40), and six plugs (41) from nose housing (36).

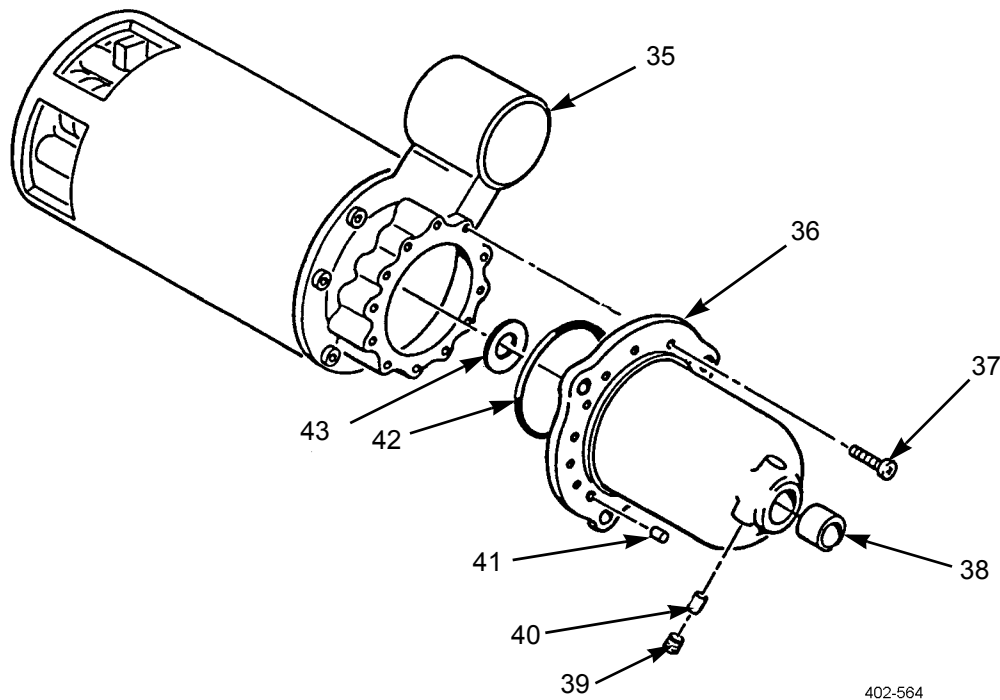

15. Remove screw (48), washer (46), shaft (49), and packing (47) from shift housing (35). Discard packing.  
 16. Remove armature (44), washer (45), drive assembly (53), insulator (51), shift lever (50), and two cams (52).

**NOTE**

Mark shift housing and field ring prior to removing shift housing to aid in installation.

17. Remove five screws (54), lockwashers (55), and shift housing (35) from field ring (26). Discard lockwashers.

DISASSEMBLY - CONTINUED

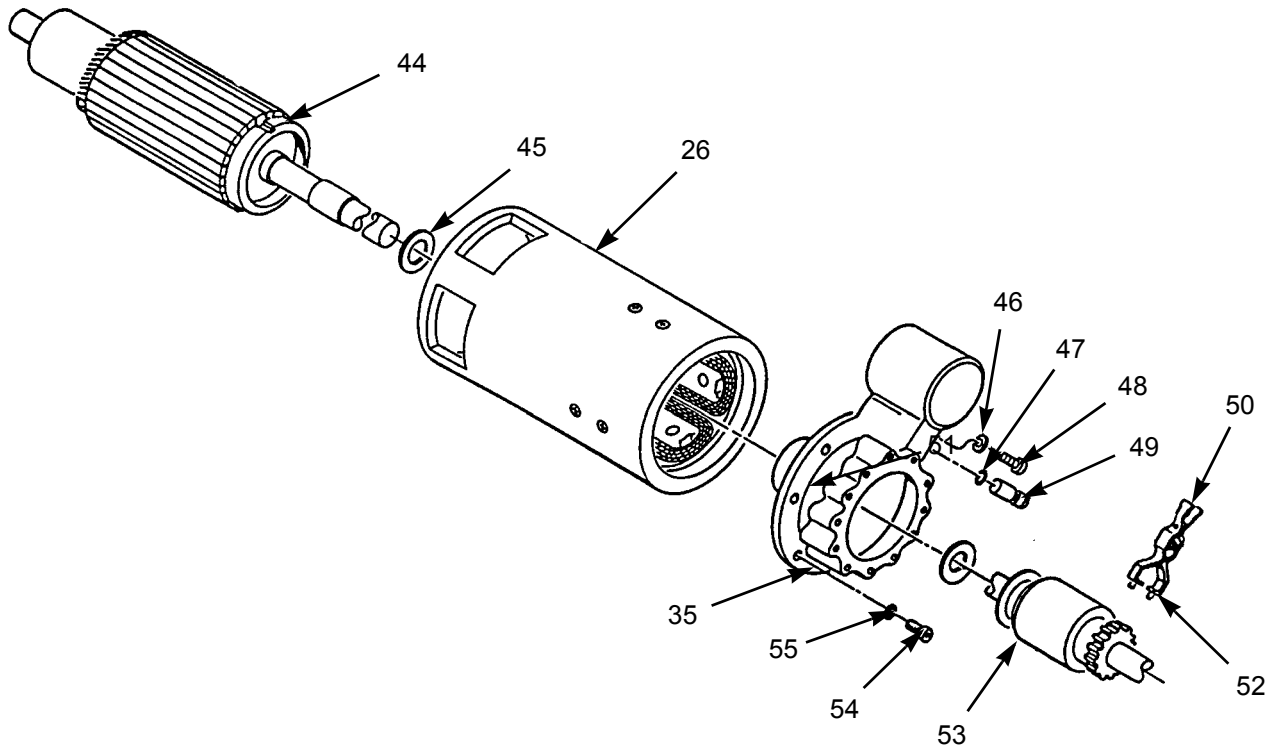

402-565

18. Remove seal (57), bushing (58), and packing (56) from shift housing (35). Discard seal and packing.

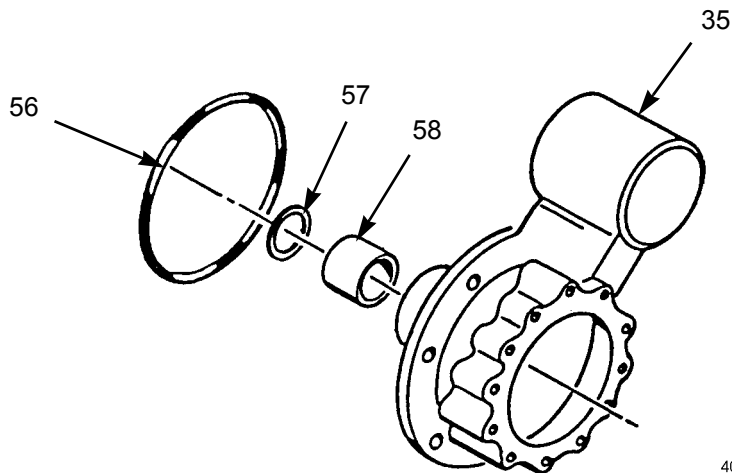

402-566

**DISASSEMBLY - CONTINUED**

19. Remove nut (59), washer (60), insulator (61), and packing (62) from field ring (26). Discard packing.

**CAUTION**

When removing stud terminal, do not use hammer to tap stud out. To do so could cause damage to components.

20. To remove stud terminal (67), temporarily replace nut (59) flush with end of stud. Using suitable pliers, work stud out while supporting field coil (65).
21. Remove insulator (68) and bushing (63) from field ring (26).
22. Remove eight screws (66), four pole pieces (64), field coil (65), and insulator (69) from field ring (26).

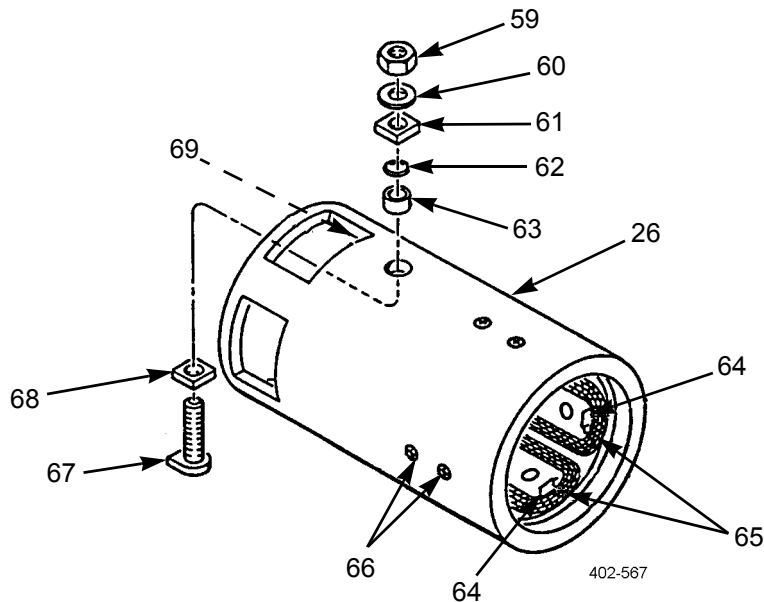
**ASSEMBLY**

1. Install insulator (69) in field ring (26).
2. Install field coil (65) in field ring (26) so that terminal stud holes in field coil and field ring line up.

**CAUTION**

Pole pieces must be installed so that slot clears field coil contact tab. Failure to do so will cause damage to starter motor.

3. Install four pole pieces (64) and eight screws (66).

**CAUTION**

Insulator must be installed between field coil and field ring. Failure to do so will cause a short, damaging starter motor.

4. Install insulator (68) and stud terminal (67) through field coil (65) and field ring (26).
5. Install bushing (63), new packing (62), insulator (61), washer (60), and nut (59) on stud terminal (67).

**ASSEMBLY - CONTINUED**

6. Install new packing (56), bushing (58), and new seal (57) in shift housing (35).

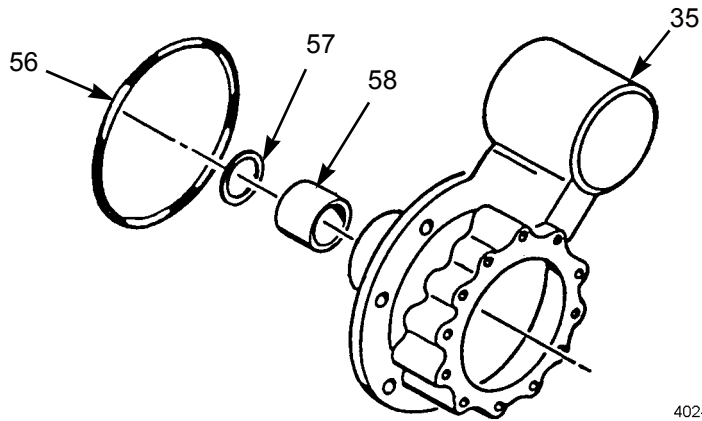

402-566

7. Install shift housing (35) on field ring (26) with five new lockwashers (55) and screws (54).
8. Install two cams (52), shift lever (50), insulator (51), drive assembly (53), washer (45), and armature (44).
9. Install new packing (47), shaft (49), washer (46), and screw (48) in shift housing (35).

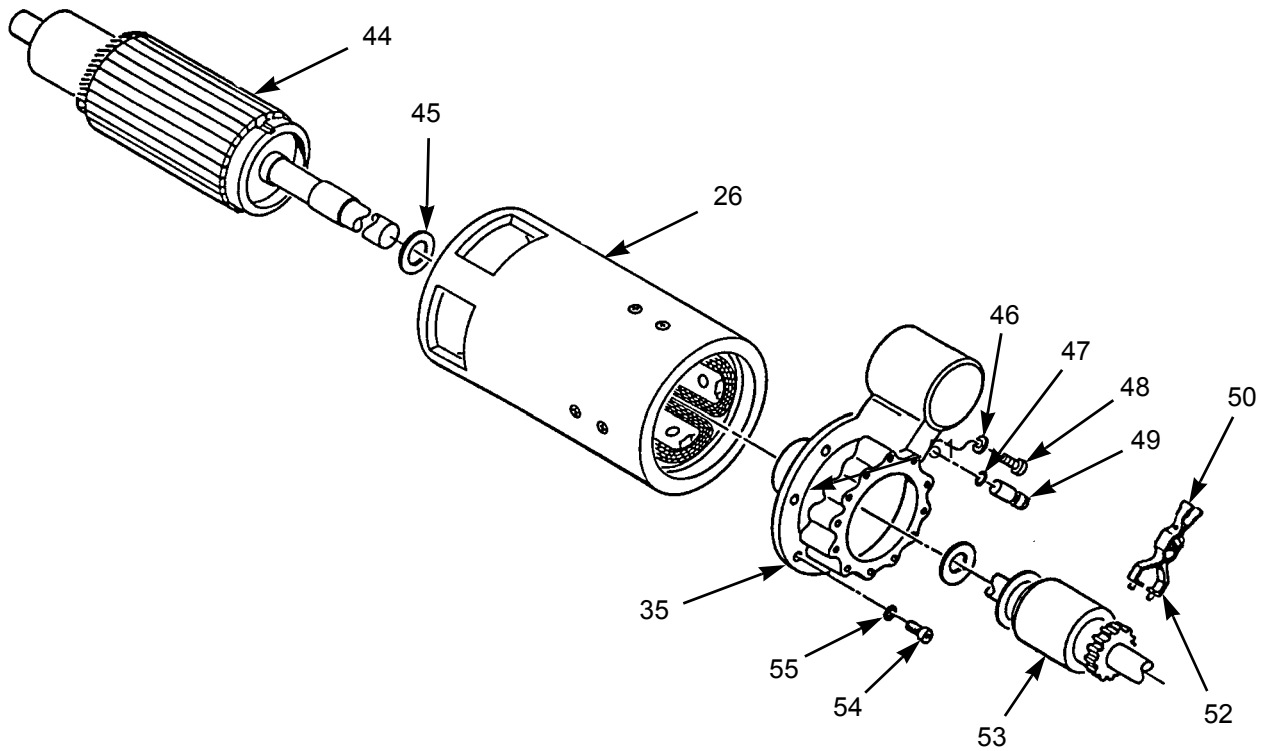

402-565

**ASSEMBLY - CONTINUED**

10. If removed, install six new plugs (41), new felt wick (40), new plug (39), and new bushing (38) in nose housing (36).

**NOTE**

Install nose housing as noted in disassembly sequence.

11. Install washer (43), packing (42), nose housing (35), and six screws (37) on shift housing (36).

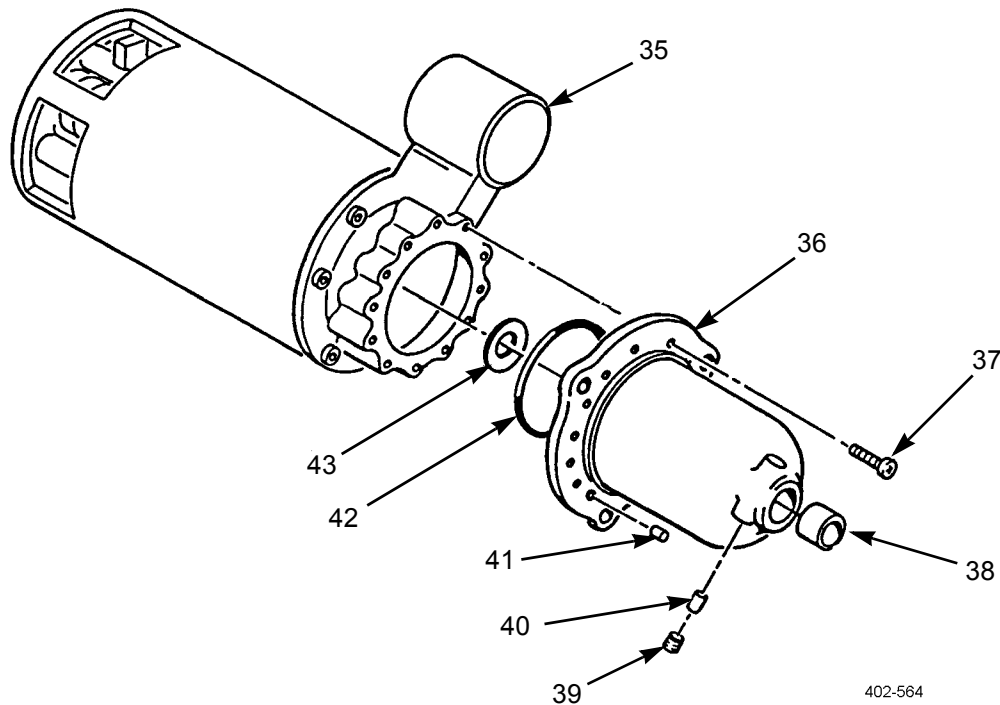

12. If removed, install new bushing (32) in commutator housing (12).
13. Install felt wick (13), pipe plug (14), and new packing (27) in commutator housing (12).
14. If removed, install new bushing (15) in commutator housing (12).
15. Install washer (18), insulation washer (17), and new packing (16) on ground stud (20).
16. Install ground stud (20) in commutator housing (12).
17. Install new packing (11), insulator (10), four washers (9), and nut (8) on ground stud (20).
18. Install ground jumper (30), four insulation washers (19), and brush holders (31) in commutator housing (12).
19. Install four insulation bushings (22), eight insulation washers (21), four washers (23), new lockwashers (24), and screws (25).
20. Install insulation washer (29), washer (28), and commutator housing (12) in field ring (26).
21. Apply silicone adhesive to threads of four screws (34) and install four new lockwashers (33) and screws.

ASSEMBLY - CONTINUED

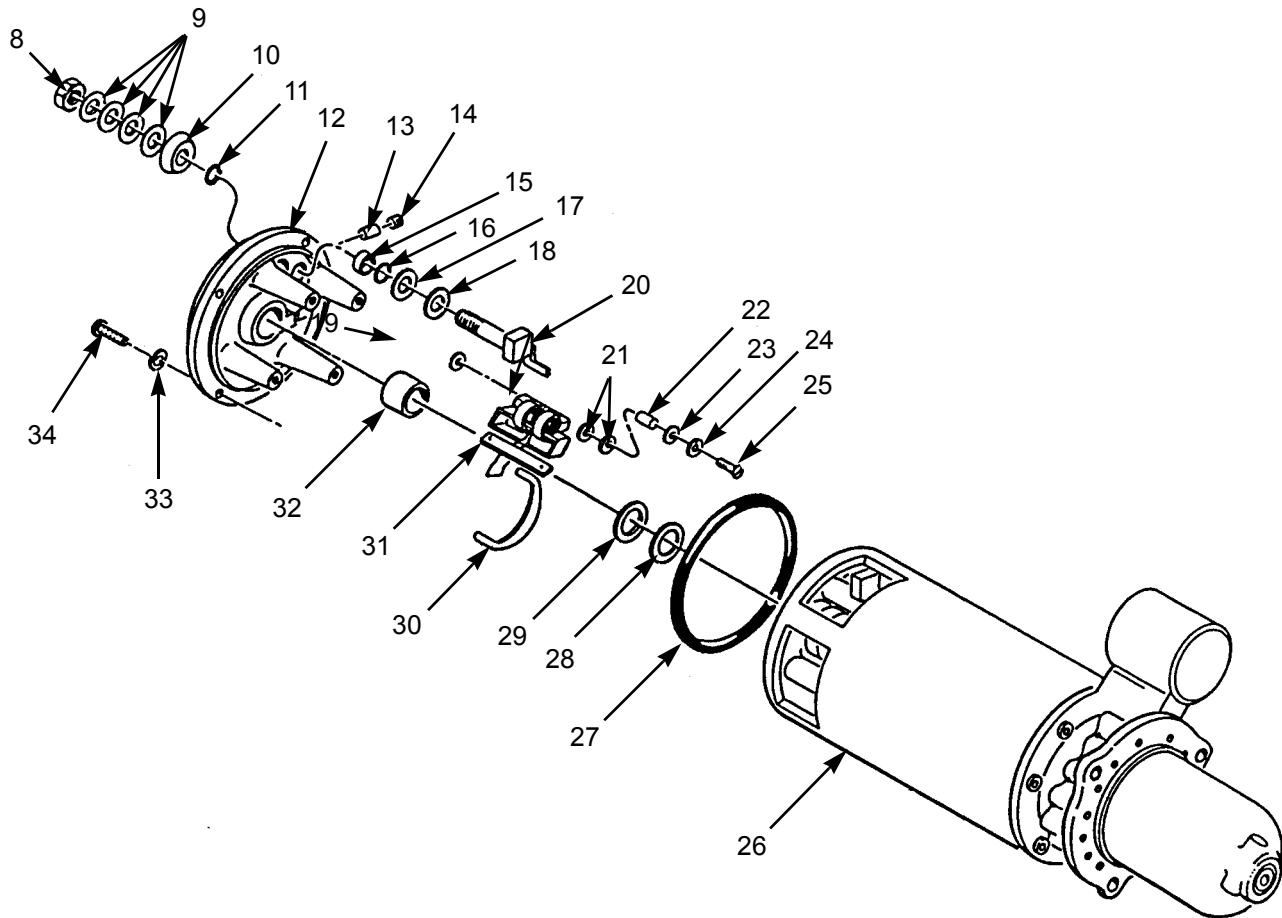

402-563

- 22. Pull two springs (5) upward and install brush (4), lock plate (7), and two screws (6).
- 23. Repeat step 22 for remaining brushes (4).

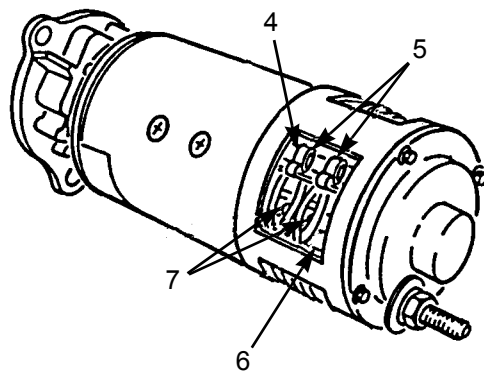

402-562

**ASSEMBLY - CONTINUED**

24. Install brush opening band (3) with two screws (1) and nuts (2).

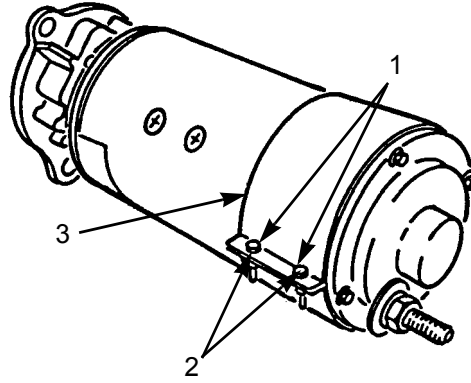

402-561

25. Install starter solenoid (WP 0234 00).

**END OF WORK PACKAGE**



---

**MAIN CAB WIRING HARNESS REPLACEMENT**

**0236 00**

---

**THIS WORK PACKAGE COVERS**

Removal/Installation

---

**INITIAL SETUP**

**Maintenance Level**

Direct Support

**Tools and Special Tools**

Tool kit, general mechanic's (Item 102, WP 0313 00)

**Materials/Parts**

Straps, tiedown (Item 41, WP 0312 00)

Tags, marker (Item 42, WP 0312 00)

**Equipment Condition**

Master battery switch in OFF position (TM 9-2320-303-10)

---

**REMOVAL/INSTALLATION**

**NOTE**

- Wiring harness and leads are secured in place by clips, tiedown straps, cushion clamps, and screw terminals. Only remove hardware securing harness to be removed.
- Tag wiring harness and leads prior to removal to aid in installation.

Refer to foldout FO-1 (M915A4) or FO-2 (M915A4R2) at end of this manual for disconnection/connection points. ■

**END OF WORK PACKAGE**



---

**SWITCH PANEL WIRING HARNESS REPLACEMENT**

---

0237 00

**THIS WORK PACKAGE COVERS**Removal/Installation

---

**INITIAL SETUP****Maintenance Level**

Direct Support

**Tools and Special Tools**

Tool kit, general mechanic's (Item 102, WP 0313 00)

**Materials/Parts**

Straps, tiedown (Item 41, WP 0312 00)

Tags, marker (Item 42, WP 0312 00)

**Equipment Condition**Master battery switch in OFF position (TM 9-2320-303-10)

---

**REMOVAL/INSTALLATION****NOTE**

- Wiring harness and leads are secured in place by clips, tiedown straps, cushion clamps, and screw terminals. Only remove hardware securing harness or lead to be removed.
- Tag wiring harness and leads prior to removal to aid in installation.

Refer to foldout FO-3 at end of this manual for disconnection/connection points. ■

**END OF WORK PACKAGE**



---

**TURN SIGNAL/MARKER LIGHT WIRING HARNESS REPLACEMENT**

---

**0238 00**

**THIS WORK PACKAGE COVERS**

Removal/Installation

---

**INITIAL SETUP**

**Maintenance Level**

Direct Support

**Tools and Special Tools**

Tool kit, general mechanic's (Item 102, WP 0313 00)

**Materials/Parts**

Straps, tiedown (Item 41, WP 0312 00)

**Equipment Condition**

Master battery switch in OFF position (TM 9-2320-303-10)

---

**REMOVAL/INSTALLATION**

**NOTE**

- Procedure is the same for both wiring harnesses.
- Wiring harness and leads are secured in place by clips, wire ties, cushion clamps, and screw terminals.
- Only remove hardware securing harness or lead to be removed.

Refer to foldout FO-4 and FO-5 at end of this manual for disconnection/connection points. ■

**END OF WORK PACKAGE**



---

**TURN SIGNAL (THRU-DECK) WIRING HARNESS REPLACEMENT**

---

**0239 00**

**THIS WORK PACKAGE COVERS**

Removal/Installation

---

**INITIAL SETUP**

**Maintenance Level**

Direct Support

**Tools and Special Tools**

Tool kit, general mechanic's (Item 102, WP 0313 00)

**Materials/Parts**

Straps, tiedown (Item 41, WP 0312 00)

**Equipment Condition**

Master battery switch in OFF position (TM 9-2320-303-10)

---

***REMOVAL/INSTALLATION***

**NOTE**

- Procedure is the same for both wiring harnesses.
- Wiring harness and leads are secured in place by clips, wire ties, cushion clamps, and screw terminals.
- Only remove hardware securing harness or lead to be removed.

Refer to foldout FO-5 at end of this manual for disconnection/connection points. ■

**END OF WORK PACKAGE**





---

**OVERHEAD CAB WIRING HARNESS REPLACEMENT**

**0240 00**

---

**THIS WORK PACKAGE COVERS**

Removal/Installation

---

**INITIAL SETUP**

**Maintenance Level**

Direct Support

**Tools and Special Tools**

Tool kit, general mechanic's (Item 102, WP 0313 00)

**Materials/Parts**

Straps, tiedown (Item 41, WP 0312 00)

**Materials/Parts - Continued**

Tags, marker (Item 42, WP 0312 00)

**Equipment Condition**

Head liners removed (WP 0177 00)

Master battery switch in OFF position (TM 9-2320-303-10)

---

**REMOVAL/INSTALLATION**

**NOTE**

- Wiring harness and leads are secured in place by clips, wire ties, cushion clamps, and screw terminals.
- Only remove hardware securing harness or lead to be removed.
- Tag wiring harness and leads prior to removal to aid in installation.

1. Refer to foldout FO-6 at end of this manual for disconnection/connection points.
2. Install head liners (WP 0177 00).

**END OF WORK PACKAGE**



---

**CHASSIS WIRING HARNESS REPLACEMENT**

**0241 00**

---

**THIS WORK PACKAGE COVERS**

Removal/Installation

---

**INITIAL SETUP**

**Maintenance Level**

Direct Support

**Tools and Special Tools**

Tool kit, general mechanic's (Item 102, WP 0313 00)

**Materials/Parts**

Straps, tiedown (Item 41, WP 0312 00)

Tags, marker (Item 42, WP 0312 00)

**Equipment Condition**

Master battery switch in OFF position (TM 9-2320-303-10)

---

**REMOVAL/INSTALLATION**

**NOTE**

- Wiring harness and leads are secured in place by clips, wire ties, cushion clamps, and screw terminals.
- Only remove hardware securing harness or lead to be removed.
- Tag wiring harness and leads prior to removal to aid in installation.

Refer to foldout FO-7 at end of this manual for disconnection/connection points. ■

**END OF WORK PACKAGE**



**FRONT ANTI-LOCK BRAKE SYSTEM (ABS) WIRING HARNESS REPLACEMENT**

**0242 00**

**THIS WORK PACKAGE COVERS**

Removal, Installation

**INITIAL SETUP**

**Maintenance Level**

Direct Support

**Tools and Special Tools**

Tool kit, general mechanic's (Item 102, WP 0313 00)

**Materials/Parts**

Straps, tiedown (Item 41, WP 0312 00)

Tags, marker (Item 42, WP 0312 00)

**Equipment Condition**

Master battery switch in OFF position (TM 9-2320-303-10)

**REMOVAL**

**NOTE**

- Note number and location of tiedown straps to aid in installation.
  - Tag wiring harness and leads prior to removal to aid installation.
1. Remove tiedown straps securing front ABS wiring harness. Discard tiedown straps.
  2. Disconnect front ABS wiring harness (1) connections, using illustration as a guide.

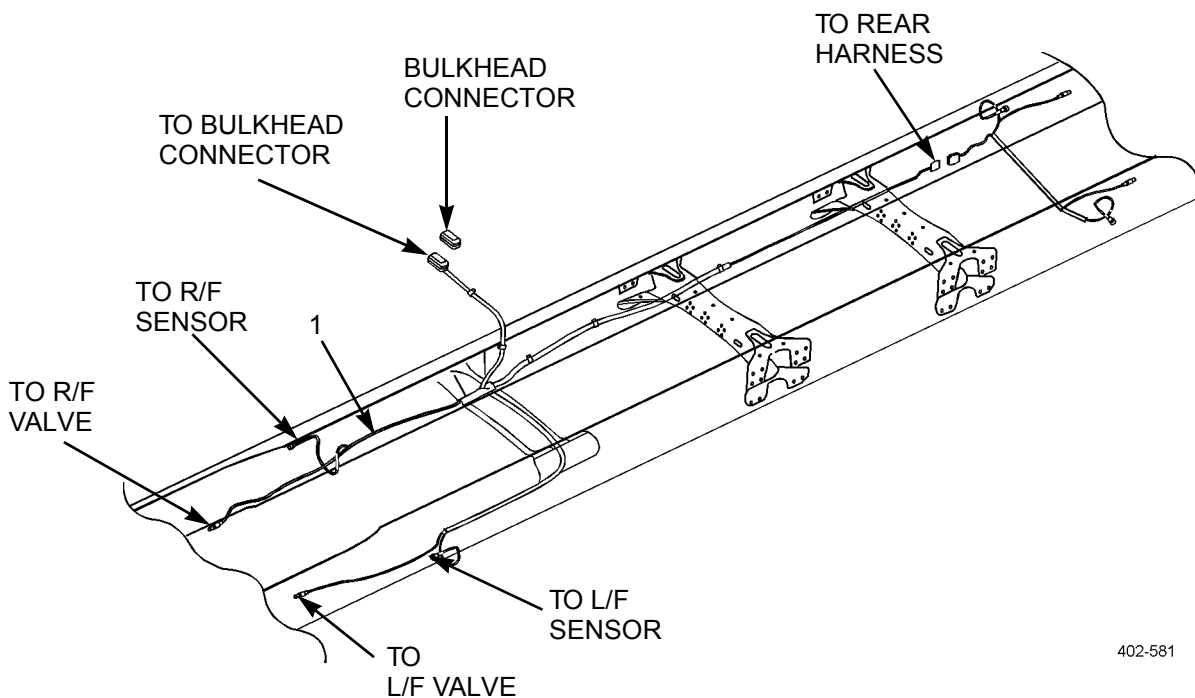

402-581

**INSTALLATION**

1. Connect front ABS wiring harness connections, using illustration as a guide.
2. Install same number of new tiedown straps as were removed, to secure front ABS wiring harness.

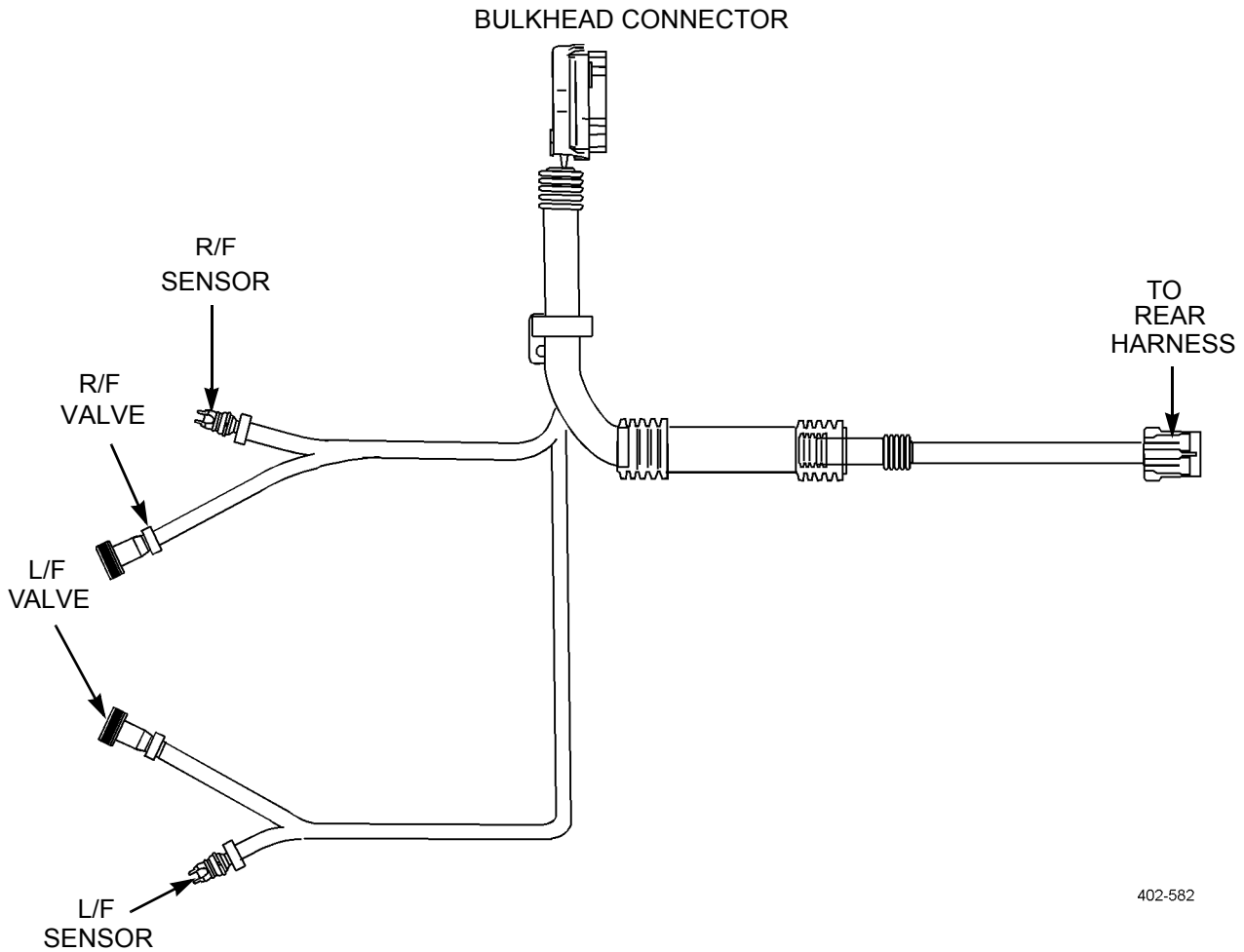

402-582

**END OF WORK PACKAGE**

**REAR ANTI-LOCK BRAKE SYSTEM (ABS) WIRING HARNESS REPLACEMENT**

**0243 00**

**THIS WORK PACKAGE COVERS**

Removal, Installation

**INITIAL SETUP**

**Maintenance Level**

Direct Support

**Tools and Special Tools**

Tool kit, general mechanic's (Item 102, WP 0313 00)

**Materials/Parts**

Straps, tiedown (Item 41, WP 0312 00)

Tags, marker (Item 42, WP 0312 00)

**Equipment Condition**

Master battery switch in OFF position (TM 9-2320-303-10)

**REMOVAL**

**NOTE**

- Note number and location of tiedown straps to aid in installation.
  - Tag wiring harness and leads prior to removal to aid in installation.
1. Remove tiedown straps securing rear ABS wiring harness. Discard tiedown straps.
  2. Disconnect rear ABS wiring harness (1) connections, using illustration as a guide.

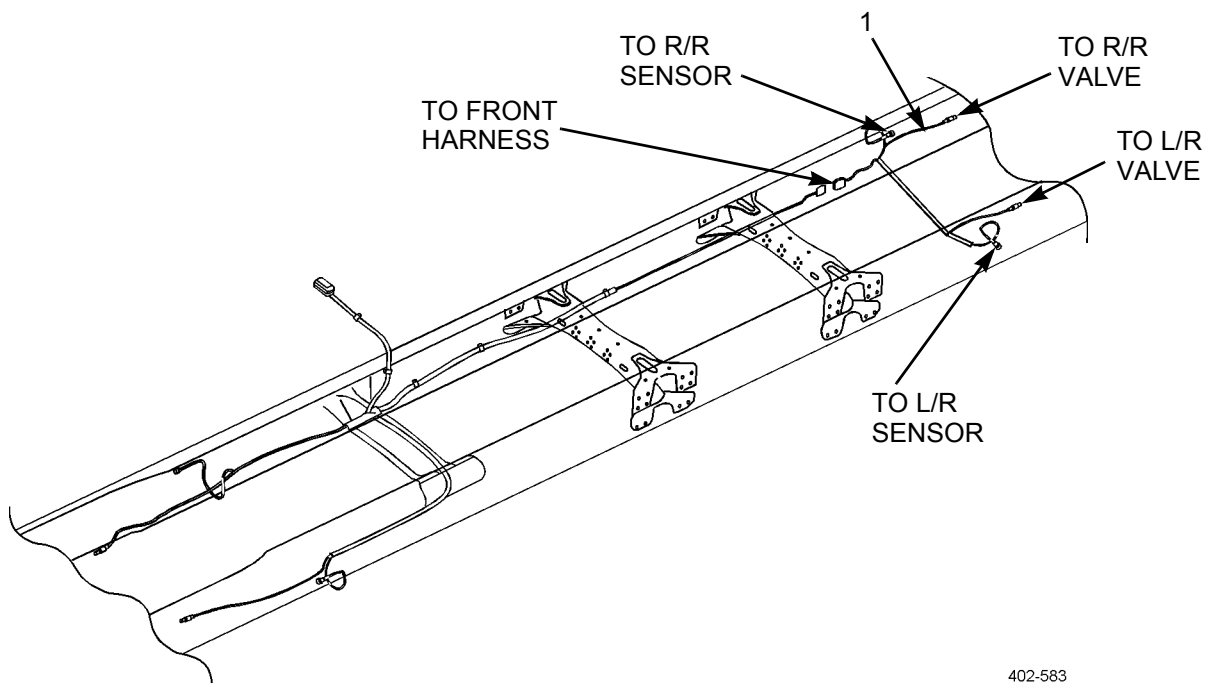

402-583

**INSTALLATION**

1. Connect rear ABS wiring harness connections, using illustration as a guide.
2. Install same number of new tiedown straps as were removed, to secure rear ABS wiring harness.

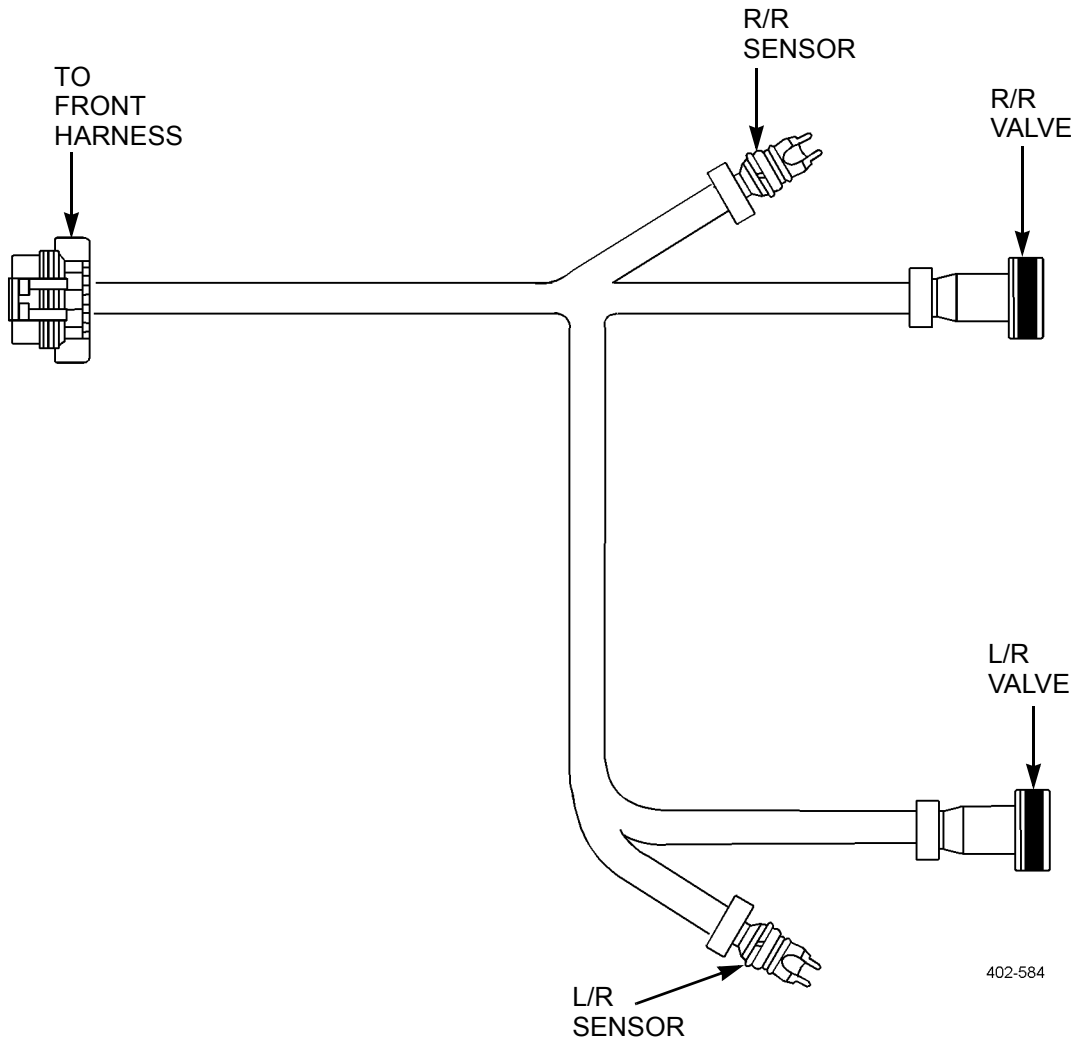

**END OF WORK PACKAGE**



---

**TAILLIGHT WIRING HARNESS REPLACEMENT**

**0244 00**

---

**THIS WORK PACKAGE COVERS**

Removal/Installation

---

**INITIAL SETUP**

**Maintenance Level**

Direct Support

**Materials/Parts**

Straps, tiedown (Item 41, WP 0312 00)

**Tools and Special Tools**

Tool kit, general mechanic's (Item 102, WP 0313 00)

**Equipment Condition**

Master battery switch in OFF position (TM 9-2320-303-10)

---

**REMOVAL/INSTALLATION**

**NOTE**

Wiring harnesses are secured in place by clips and cable ties. Remove clips and cable ties as necessary.

Refer to foldout FO-8 at end of this manual for disconnection/connection points.

**END OF WORK PACKAGE**



---

**ENGINE WIRING HARNESS REPLACEMENT**

**0245 00**

---

**THIS WORK PACKAGE COVERS**

Removal/Installation

---

**INITIAL SETUP**

**Maintenance Level**

Direct Support

**Tools and Special Tools**

Tool kit, general mechanic's (Item 102, WP 0313 00)

**Materials/Parts**

Straps, tiedown (Item 41, WP 0312 00)

Tags, marker (Item 42, WP 0312 00)

**Equipment Condition**

Master battery switch in OFF position (TM 9-2320-303-10)

---

***REMOVAL/INSTALLATION***

**NOTE**

- Wiring harness and leads are secured in place by clips, tiedown straps, cushion clamps, and screw terminals. Only remove hardware securing harness or lead to be removed.
- Tag wiring harness and leads prior to removal to aid in installation.

Refer to foldout FO-9 at end of this manual for disconnection/connection points. ■

**END OF WORK PACKAGE**



---

**RADIO WIRING HARNESS REPLACEMENT**

**0246 00**

---

**THIS WORK PACKAGE COVERS**

Removal/Installation

---

**INITIAL SETUP**

**Maintenance Level**

Direct Support

**Tools and Special Tools**

Tool kit, general mechanic's (Item 102, WP 0313 00)

**Materials/Parts**

Straps, tiedown (Item 41, WP 0312 00)

**Equipment Condition**

Head liners removed (WP 0177 00)

Master battery switch in OFF position (TM 9-2320-303-10)

---

**REMOVAL/INSTALLATION**

**NOTE**

- Wiring harness and leads are secured in place by clips, wire ties, cushion clamps, and screw terminals.
- Only remove hardware securing harness or lead to be removed.

1. Refer to foldout FO-10 at end of this manual for disconnection/connection points.
2. Install lead liners (WP 0177 00).

**END OF WORK PACKAGE**



---

**COLLISION WARNING SYSTEM (CWS) WIRING HARNESS REPLACEMENT**

---

**0247 00**

**THIS WORK PACKAGE COVERS**

Removal, Installation

---

**INITIAL SETUP**

**Maintenance Level**

Direct Support

**Tools and Special Tools**

Tool kit, general mechanic's (Item 102, WP 0313 00)

**Materials/Parts**

Straps, tiedown (Item 41, WP 0312 00)

Tags, marker (Item 42, WP 0312 00)

**Equipment Condition**

Master battery switch in OFF position (TM 9-2320-303-10)

---

**REMOVAL**

**NOTE**

- Wiring harness and leads are secured in place by clips, tiedown straps, cushion clamps and screw terminals. Only remove hardware securing harness or lead to be removed.
- Tag wiring harness and leads prior to removal to aid in installation.

Disconnect and remove CWS wiring harness (1), using illustration as a guide.

**INSTALLATION**

**NOTE**

Wiring harness and leads are secured in place by clips, new tiedown straps, cushion clamps and screw terminals. Ensure harness is secure and all hardware is tight.

Install, connect, and secure CWS wiring harness (1), using illustration as a guide.

**INSTALLATION - CONTINUED**

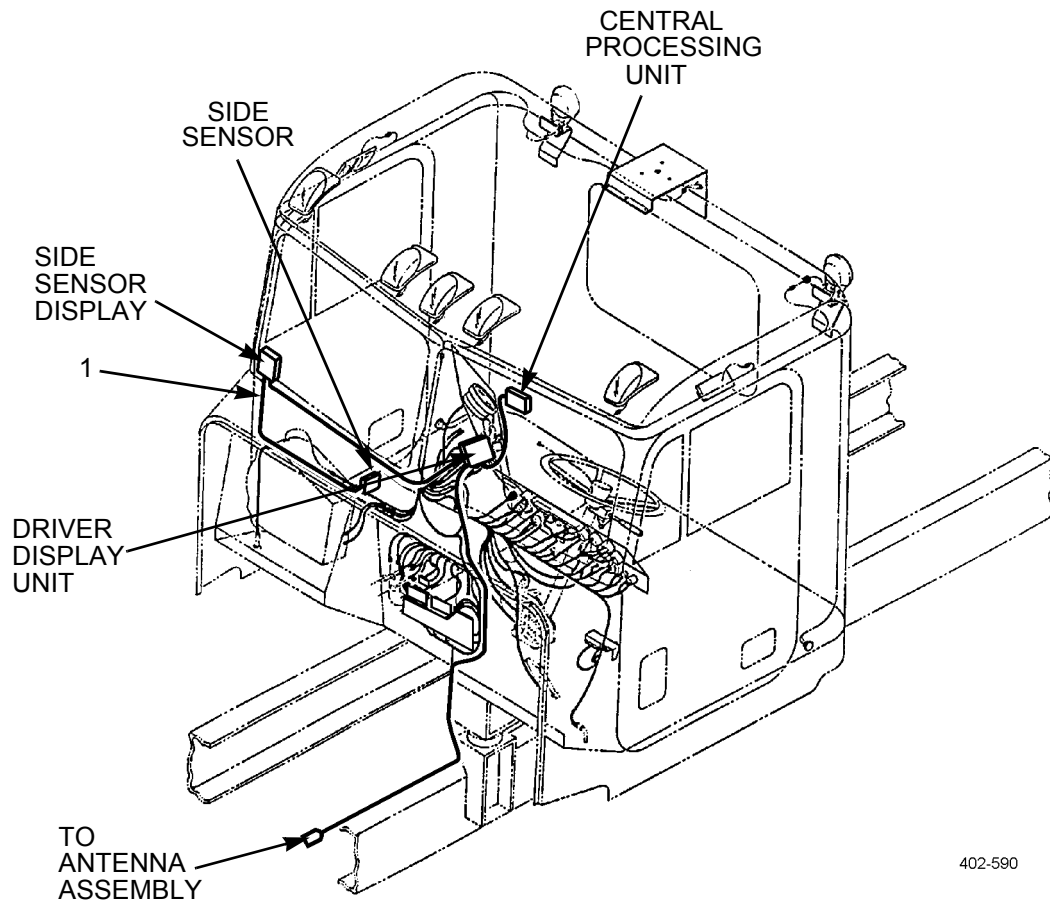

402-590

**END OF WORK PACKAGE**



**THIS WORK PACKAGE COVERS**

Disassembly, Module Overhaul, Assembly, Tabulated Data

**INITIAL SETUP****Maintenance Level**

General Support

**Tools and Special Tools**

Tool kit, general mechanic's (Item 102, WP 0313 00)

Tool kit, transmission (Item 104, WP 0313 00)

Adapter, torque wrench (Item 2, WP 0313 00)

Bracket, mounting (Item 6, WP 0313 00)

Bracket, vehicular components (Item 7, WP 0313 00)

Bushing, sleeve (Item 8, WP 0313 00)

Caliper, micrometer (Item 9, WP 0313 00)

Compressor, spring (Item 12, WP 0313 00)

Compressor, spring (Item 13, WP 0313 00)

Compressor, spring (Item 14, WP 0313 00)

Gage, depth, micrometer (Item 23, WP 0313 00)

Gage, profile (Item 25, WP 0313 00)

Insertor and remover (Item 38, WP 0313 00)

Insertor and remover (Item 40, WP 0313 00)

Insertor, bearing and bushing (Item 41, WP 0313 00)

Insertor, bearing and bushing (Item 42, WP 0313 00)

Insertor, bearing and bushing (Item 43, WP 0313 00)

Insertor, bearing and bushing (Item 44, WP 0313 00)

Insertor, bearing and bushing (Item 45, WP 0313 00)

Insertor, bearing and bushing (Item 46, WP 0313 00)

Insertor, seal (Item 47, WP 0313 00)

Insertor, seal (Item 48, WP 0313 00)

**Tools and Special Tools - Continued**

Insertor, seal (Item 49, WP 0313 00)

Insertor, seal (Item 50, WP 0313 00)

Installer, seal (Item 51, WP 0313 00)

Lifting bracket, flywheel (Item 57, WP 0313 00)

Parts kit, valves (Item 63, WP 0313 00)

Press, arbor (Item 71, WP 0313 00)

Puller kit, universal (Item 74, WP 0313 00)

Remover, wheel bearing cup (Item 76, WP 0313 00)

Ring, retaining (Item 77, WP 0313 00)

Ring, retaining (Item 78, WP 0313 00)

Sling, nylon (Item 86, WP 0313 00)

Socket, socket wrench (Item 88, WP 0313 00)

Socket, socket wrench (Item 89, WP 0313 00)

Spanner (Item 91, WP 0313 00)

Switch, pressure (Item 95, WP 0313 00)

Wrench, torque, 0-300 lb-in (Item 109, WP 0313 00)

Wrench, torque, 15-75 lb-ft (Item 110, WP 0313 00)

**Materials/Parts**

Oil, lubricating (Item 27, WP 0312 00)

Petrolatum, technical (Item 37, WP 0312 00)

Tags, marker (Item 42, WP 0312 00)

**Personnel Required**

Two

**Equipment Condition**

Transmission installed on maintenance stand

Engine, turbine, and output speed sensors removed (WP 0112 00)

**DISASSEMBLY**

Use extreme caution when handling heavy parts. Provide adequate support and use assistance during procedure. Ensure that any lifting device used is in good condition and of suitable load capacity. Keep clear of heavy parts supported only by lifting device. Failure to follow this warning may result in death or injury to personnel.

**NOTE**

Confirm transmission has been drained prior to disassembly.

**Removal of Filters and Breather**

1. Remove 12 bolts (6), two filter covers (5), O-rings (4), square cut seals (3), and filters (2). Discard O-rings, seals, and filters.
2. Remove transmission breather vent (1) from torque converter housing.

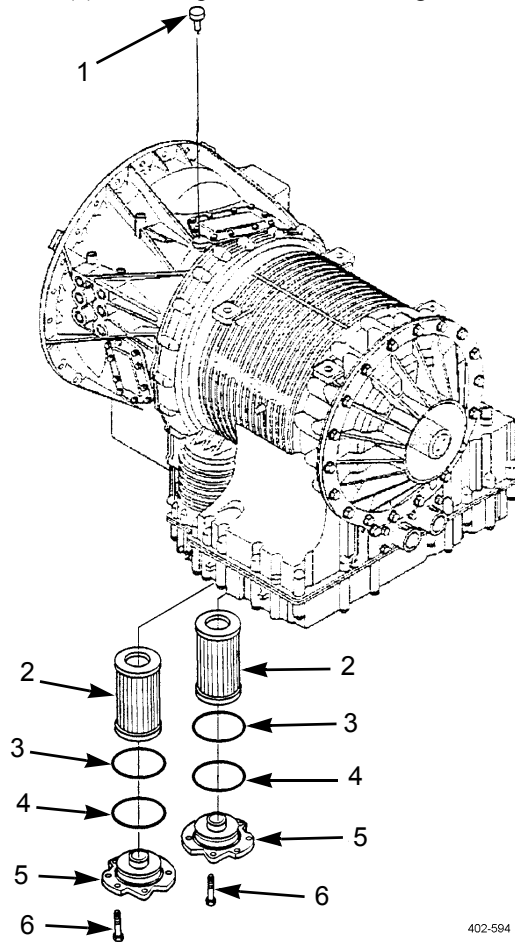

402-594

**DISASSEMBLY - CONTINUED****Removal of Output Shaft and Oil Seal**

1. Remove bolt (12), retainer plug (11), and O-rings (9 and 10) from output shaft yoke (8). Discard O-rings.
2. Remove oil seal (7) using puller (J24171-A). Discard oil seal.

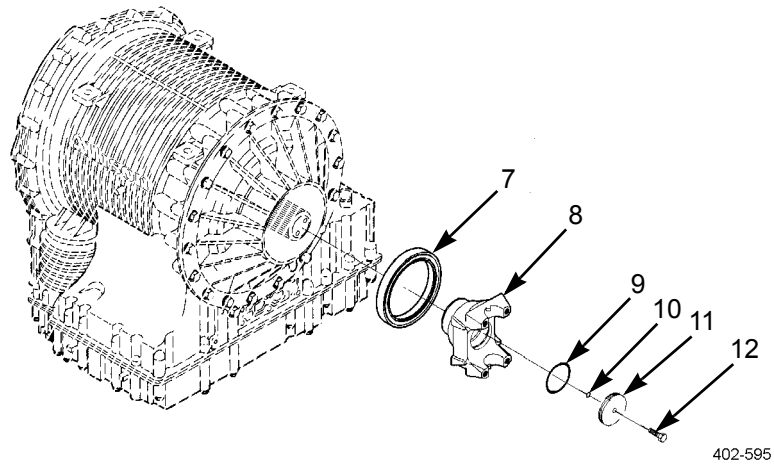

**DISASSEMBLY - CONTINUED****Removal of Torque Converter Module**

1. Remove bolts securing torque converter shipping brackets(s). Remove bracket(s).
2. Remove retaining ring (21) securing torque converter plug (20).
3. Using an M6x30-1 bolt threaded into torque converter plug (20), remove torque converter plug and O-ring (13). Discard O-ring.

**NOTE**

While attempting to remove torque converter center bolt, converter will rotate. Follow procedure in step 4 to hold converter stationary.

4. Install two bolts (17) into flexplate adapter (18). Use two bars at an angle to prevent rotation of torque converter (15).
5. Remove converter center bolt (14), using bolt tool (J38564).
6. Remove and tag shim(s) (19).
7. Remove torque converter holding bars and bolts (17).
8. Attach a suitable lifting sling to flexplate adapter (18) by positioning adapter connections equal distances apart from each other.
9. Using a suitable hoist, remove torque converter (15) from torque converter housing (16). Place torque converter on a work bench supported by two wooden blocks.

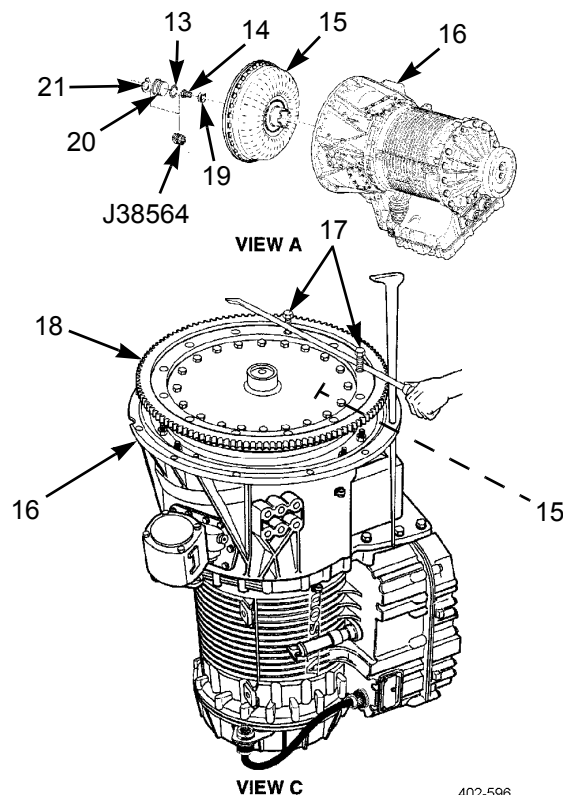

402-596

**DISASSEMBLY - CONTINUED****Removal of Torque Converter Housing Module**

1. Remove seven bolts (25), from inside of torque converter housing (22), that secure converter housing to main housing (24). Remove remaining 18 bolts from outside of housing.
2. Attach suitable lifting sling and hoist to torque converter housing (22).
3. Remove torque converter housing (22) and gasket (23) from main housing (24). Discard gasket.

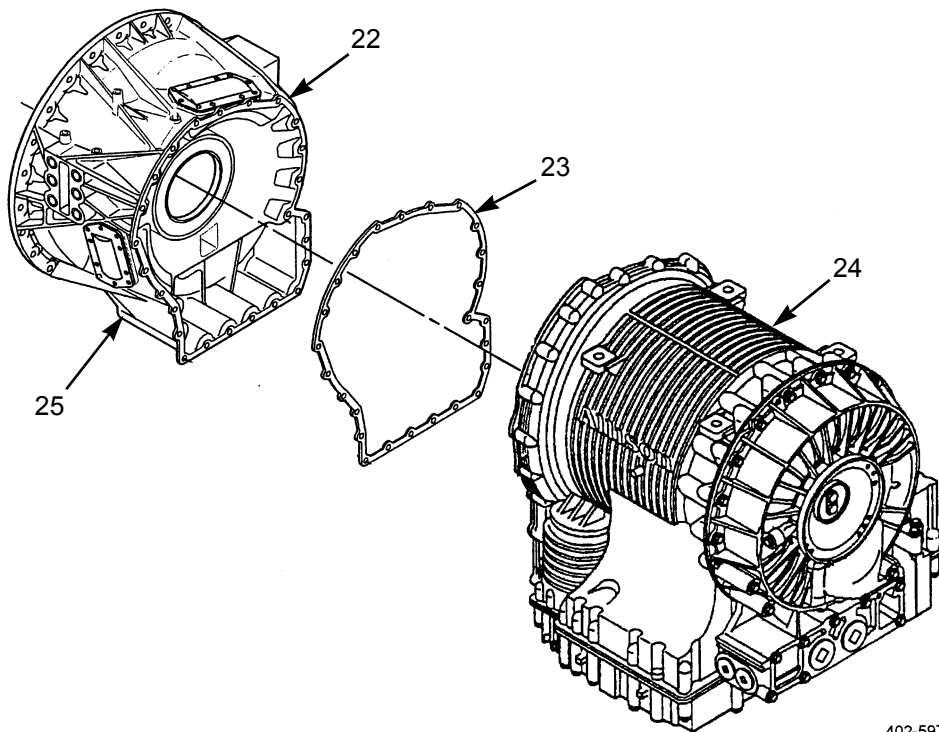

402-597

**DISASSEMBLY - CONTINUED****Removal of Control Valve Module****NOTE**

Control module and filters may contain residual transmission fluid.

1. Remove retaining nut (27) and lockwasher (28) securing feed-through harness (29) to mounting bracket (26). Do not discard lockwasher unless damaged.
2. Remove retaining nut (30) and lockwasher (31) securing feed-through harness (29) to main housing (24). Do not discard lockwasher unless damaged.

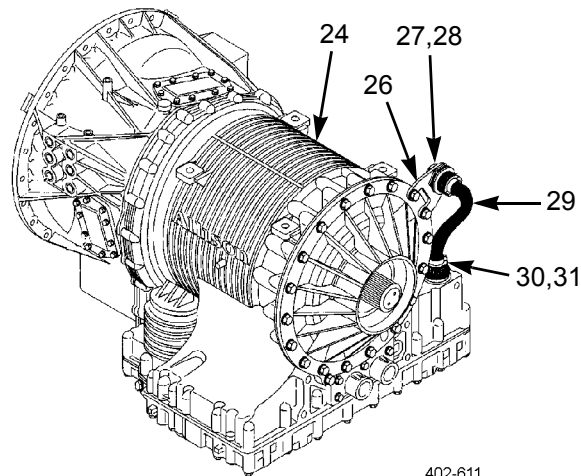

3. Remove 43 bolts (34) securing control module (33) to main housing (24).
4. Loosen control module (33) from main housing (24) by installing jacking screws into control module bolt holes that bottom out against main housing.
5. Remove control module (33) and gasket (32) from main housing (24). Discard gasket.

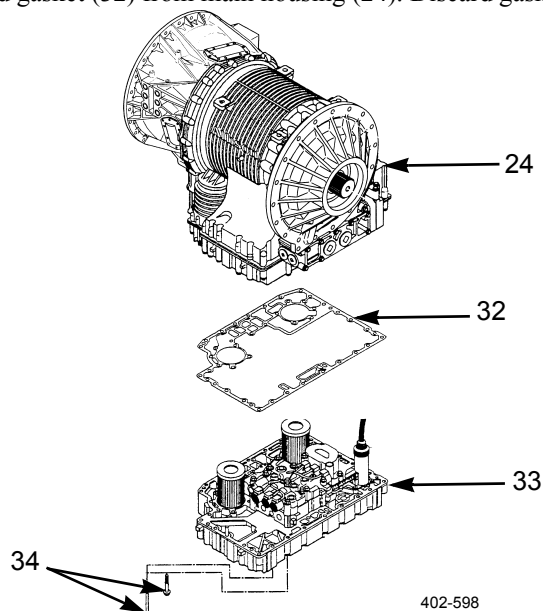

**DISASSEMBLY - CONTINUED**

**Removal of Rear Cover Module**

1. Remove 19 bolts (35) securing rear cover module (36) to main housing (24).
2. Remove rear cover module (36) and gasket (37) from main housing (24). Discard gasket.

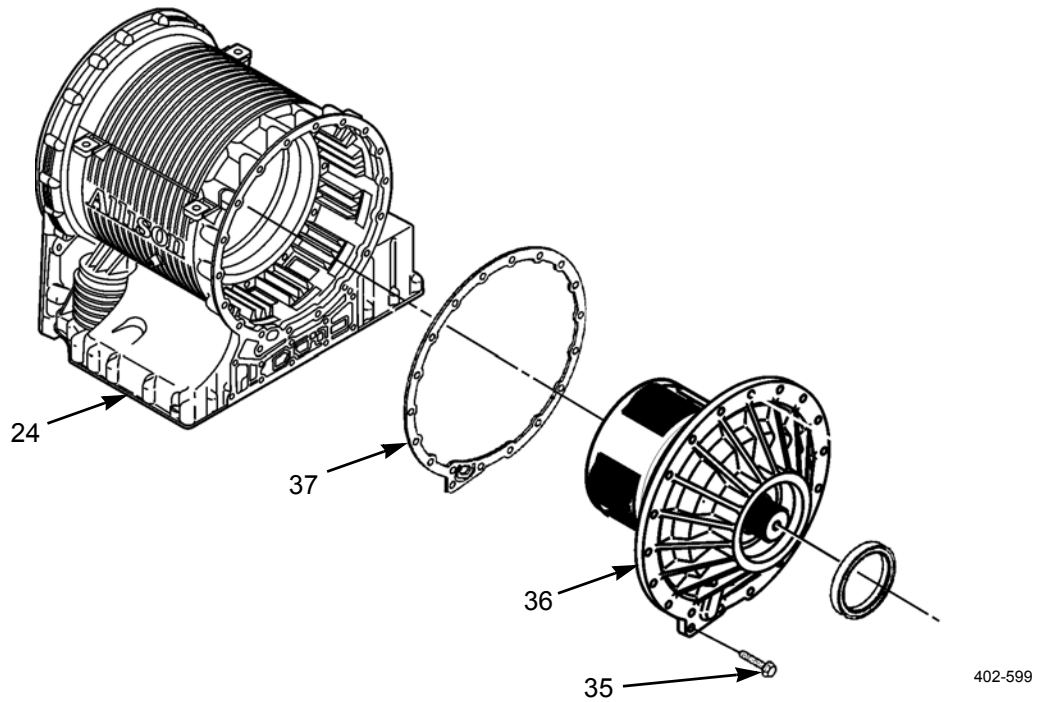

**Removal of Main Shaft Module**

Remove main shaft module assembly (38) with thrust bearing (39) and selective shim (40) from main housing (24). Tag thrust bearing and shim to aid in assembly and identification.

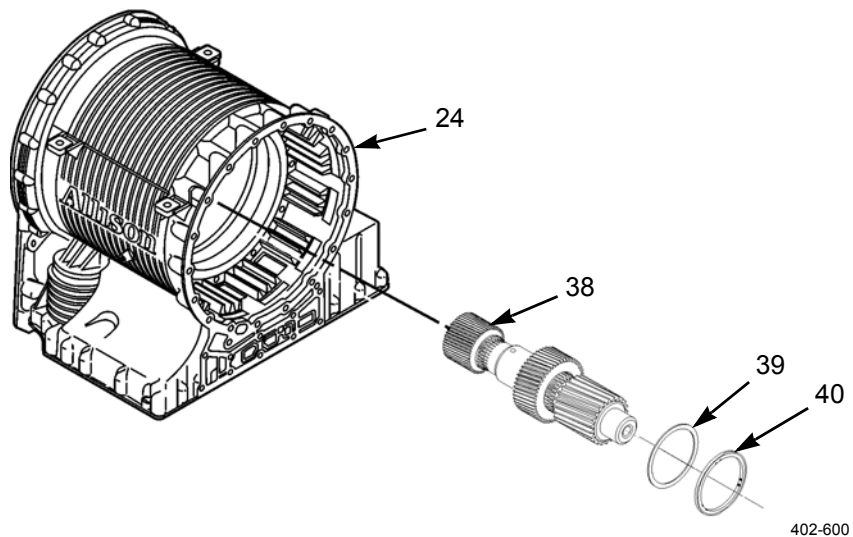

**DISASSEMBLY - CONTINUED****Removal of P2 Planetary Module, C5 Clutch Pack, and P1 Planetary Module**

1. Lift P2 planetary module (41) from main housing (24).
2. Lift C5 clutch pack (42), containing eight friction plates (43) and nine steel reaction plates (44), from main housing (24).
3. Measure, tag, and note thickness and cone of each friction plate (43). Minimum thickness is 0.137 in (3.48 mm). Maximum allowable cone is 0.010 in (0.25 mm).
4. Measure, tag, and note thickness and cone of each steel reaction plate (44). Minimum thickness is 0.095 in (2.41 mm). Maximum allowable cone is 0.010 in (0.25 mm).
5. Lift P1 planetary module (45) from main housing (24).

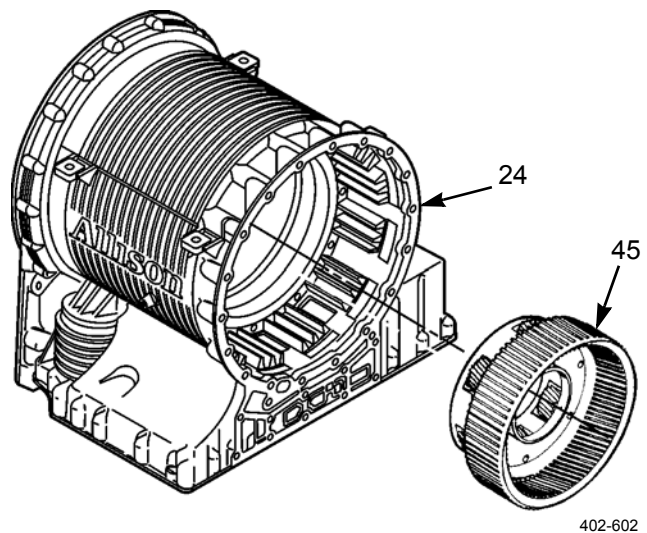
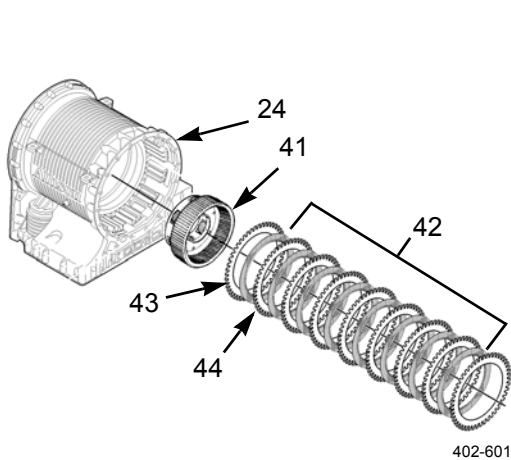
**Removal of Front Support and Charging Pump Module and Rotating Clutch Module****NOTE**

Note size and position of 14 bolts securing front support and charging pump module to main housing, to aid during assembly.

1. Remove seven bolts (48) and seven bolts (46) securing front support and charging pump module (47) to main housing (24).
2. Lift front support and charging pump module (47) from main housing (24).
3. Install an M16 lifting eye bolt into turbine shaft (49). Attach a suitable hoist to lifting eye.
4. Using hoist, remove turbine shaft (49) and rotating clutch module (50) from main housing (24).



**DISASSEMBLY - CONTINUED**

**Removal of Front Support and Charging Pump Module and Rotating Clutch Module - Continued**

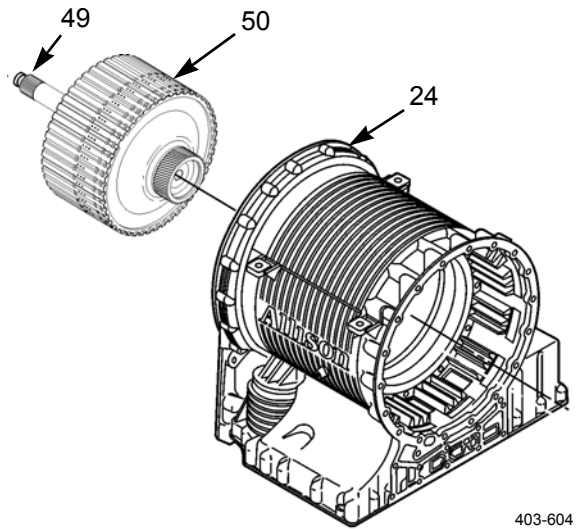
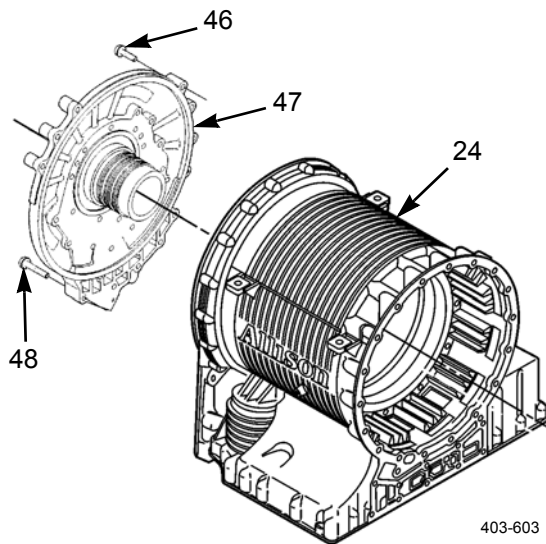

**Removal of C3/C4 Clutch Assembly**

1. Remove 14 bolts (52) securing C3/C4 clutch assembly (51) in main housing (24).
2. Remove C3/C4 clutch assembly (51) by sliding it out of input end of housing.
3. Inspect and measure C5 clutch plate splines inside main housing for wear. Maximum wear allowed is 0.045 in (1.15 mm).

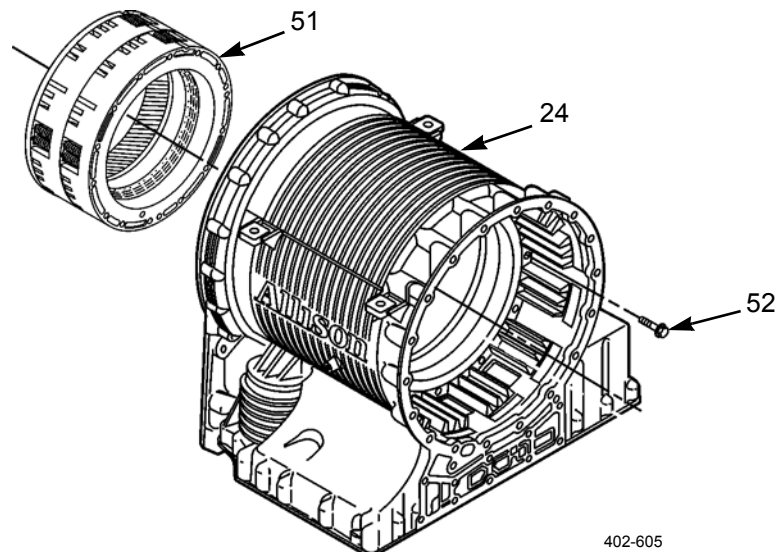

**MODULE OVERHAUL****Torque Converter Module Disassembly****NOTE**

Prior to disassembling torque converter, note balance marks or mark a line across converter cover to pump assembly with a scribe. These marks will ensure correct assembly of torque converter and reduce balance problems.

1. Place converter assembly (6) on a flat work surface with pump drive tangs downward.
2. Remove 36 nuts (1) from outer diameter of cover assembly (2).
3. Remove 36 T-headed bolts (12) from outer diameter of pump assembly (13).
4. Carefully, without prying, remove cover assembly (2) from pump assembly (13).
5. Remove and discard O-ring (15) from between converter assembly halves.
6. Remove turbine assembly (28) from cover assembly (2).
7. Remove stator assembly (19) from pump assembly (13).
8. Remove thrust bearing race (14) from pump assembly (13).
9. Remove thrust bearing assembly (27) from turbine assembly (28).
10. Remove bearing assembly (16), race (17), and selective shim (18) from pump assembly (13).
11. Remove retaining ring (25) and star plate (26) from stator assembly (19).

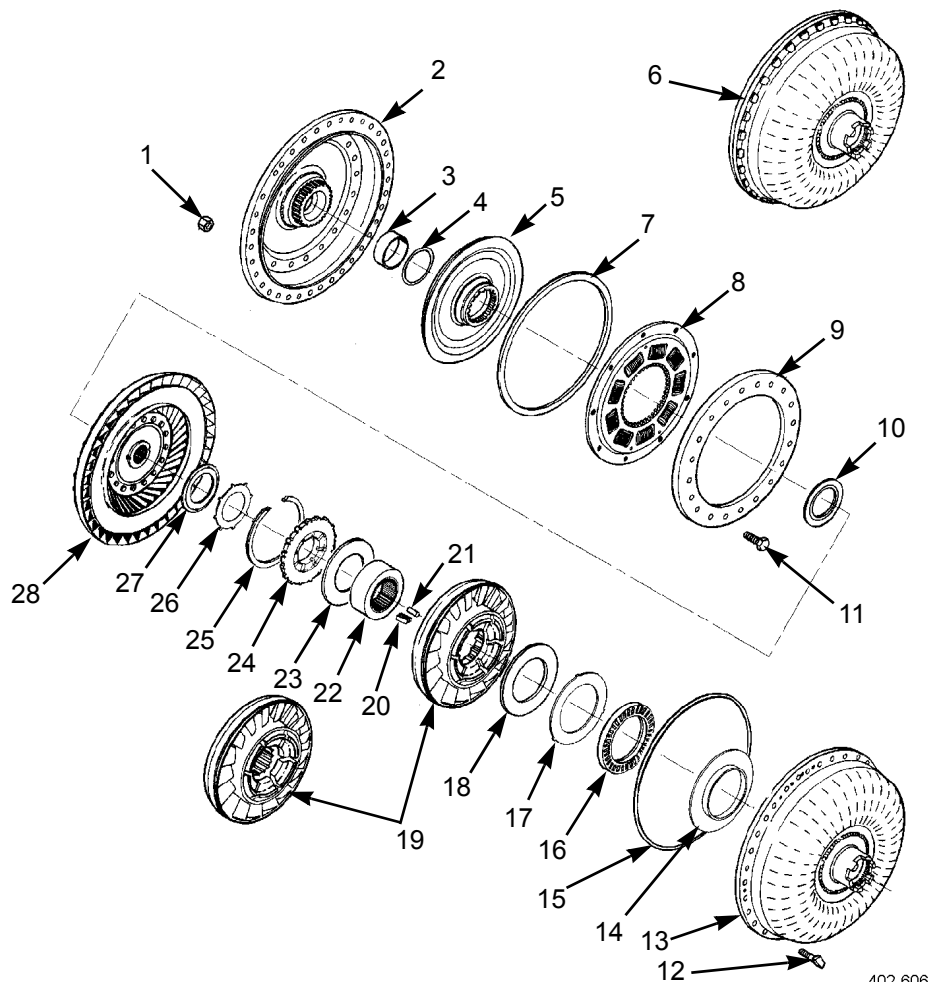

402-606

**MODULE OVERHAUL - CONTINUED****Torque Converter Module Disassembly - Continued**

12. Remove thrust plate (24) from stator assembly (19). Measure, note, and tag thrust plate. Minimum thickness allowed is 0.372 in (9.45 mm).
13. Remove thrust washer (23) from stator assembly (19).
14. Remove stator race (22), 13 springs (20), and rollers (21). Inspect components for damage.
15. Remove 44 bolts (11) securing lockup clutch backup plate (9) to cover assembly (2). Remove backup plate from cover.
16. Measure thickness of backup plate wear surface. Minimum thickness allowed is 0.464 in (11.79 mm). Check for backup plate distortion. Maximum distortion allowed is 0.006 in (0.15 mm).
17. Remove lockup clutch damper assembly (8) from cover assembly (2). Perform the following measurements.
  - a. Lockup clutch thickness: minimum thickness allowed is 0.335 in (8.51 mm).
  - b. Lockup clutch distortion: maximum allowable distortion is 0.020 in (0.51 mm).
  - c. Spline wear check: measure between turbine and lockup clutch damper. Maximum allowable wear is 0.015 in (0.38 mm) on either spline.
18. Remove lockup clutch piston (5), inner seal ring (4), and outer seal ring (7) from cover assembly (2). Measure thickness of lockup clutch piston. Minimum thickness allowed is 0.257 in (6.53 mm).
19. Inspect and measure inside diameter (ID) of converter cover bushing (3). Maximum allowed inside diameter of bushing is 2.634 in (66.90 mm). Remove bushing if replacement is necessary.
20. Remove thrust bearing (10) from converter cover (2).

**Torque Converter Module Assembly**

1. Install stator race (22) into stator assembly (19).
2. Install 13 springs (20) and rollers (21) into stator assembly (19). Use petrolatum to help hold springs and rollers in place.

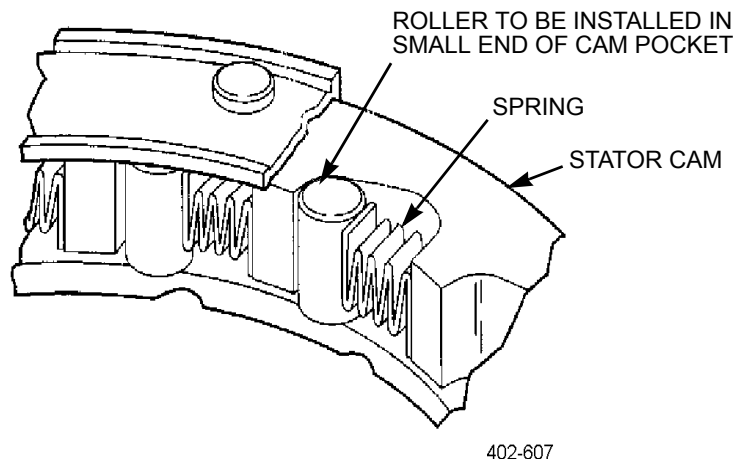

**MODULE OVERHAUL - CONTINUED****Torque Converter Module Assembly - Continued**

3. Install thrust washer (23) and thrust plate (24) on stator assembly (19).
4. Install star plate (26) and retaining ring (25).
5. Install bearing assembly (16), race (17), and selective shim (18) to pump assembly (13).

**CAUTION**

When installing thrust bearings, ensure that locating lip on either inner or outer thrust bearing race is not preventing race from contacting thrust surface of mating part. Failure to follow this caution leads to premature thrust bearing failure and incorrect shim selection to maintain proper internal part clearance.

6. Install thrust bearing assembly (27) into turbine assembly (28).
7. If removed, install new bushing (3) into cover assembly (2), using installer tool (J39949).
8. Insert turbine assembly (28) into converter cover bushing (10). Check for free rotation.
9. Install thrust bearing (10) in cover assembly (2).
10. Install lockup clutch piston inner seal ring (4) on hub of cover assembly (2).
11. Install lockup clutch piston outer seal ring (7) on outside diameter of lockup clutch piston (5).
12. Install lockup clutch piston (5).
13. Install lockup clutch damper assembly (8) in cover assembly (2).
14. Install lockup clutch backup plate (9). Secure backup plate with 44 bolts (11). Tighten bolts to 22-26 lb-ft (30-35 Nm).
15. Install turbine (28) into cover assembly (2), aligning balance mark on turbine with balance mark on lockup clutch damper assembly (8).
16. Install stator assembly (19) in cover assembly (2).
17. Install 36 T-headed bolts (12) into flange of pump assembly (13).
18. Install thrust bearing race (14) into pump assembly (13).
19. Install O-ring (15) onto cover assembly (2).
20. With balance marks aligned, position pump assembly (13) over cover assembly (2).
21. Install four nuts (1) evenly spaced around cover assembly (2) onto T-headed bolts (12). Tighten nuts to 22-26 lb-ft (30-35 Nm).

MODULE OVERHAUL - CONTINUED

Torque Converter Module Assembly - Continued

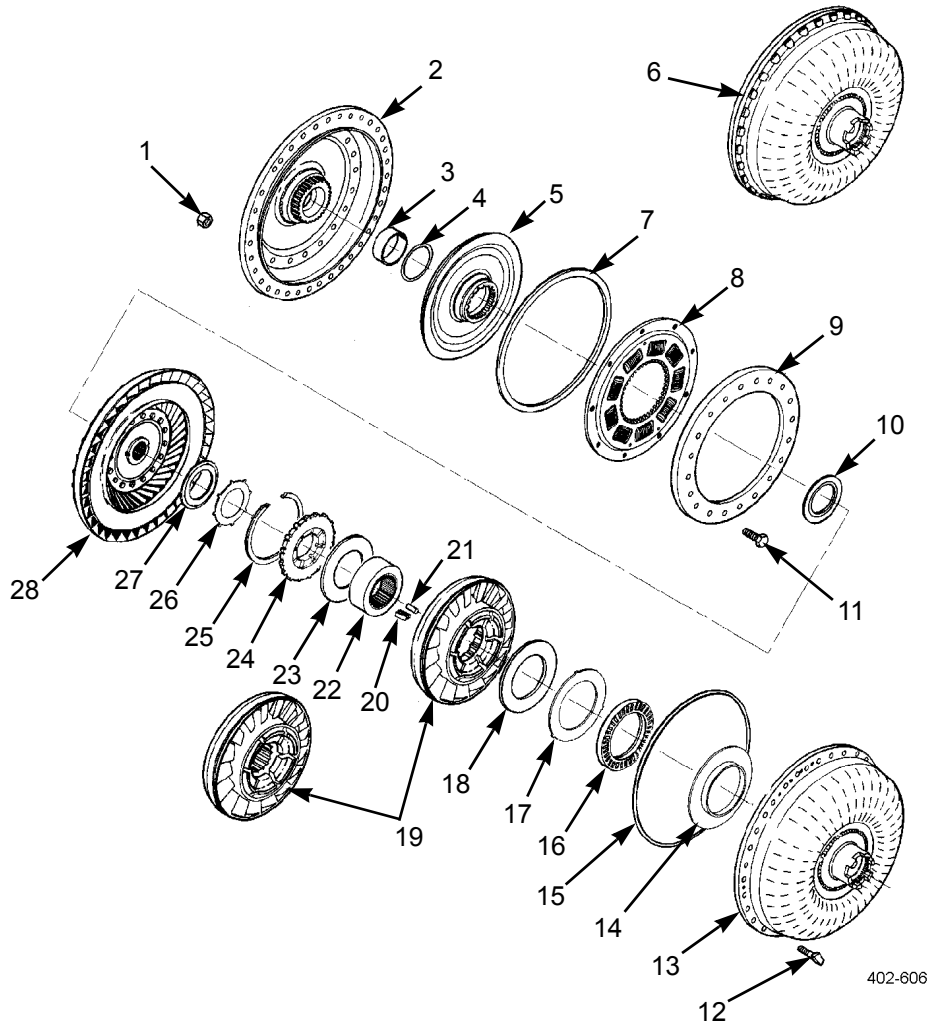

**MODULE OVERHAUL - CONTINUED**

**Torque Converter Module Assembly - Continued**

**NOTE**

Perform steps 22 through 27 to determine torque converter selective shim dimensions.

22. Using a depth micrometer, measure from top of torque converter drive tang surface to thrust surface of turbine hub. This dimension is "A".
23. Remove bolt from tool (J38548). Install tool into torque converter and position converter on work surface so converter is supported by tool.
24. Using a depth micrometer, measure from top of torque converter drive tang surface to thrust surface of turbine hub. This dimension is "B".
25. Subtract dimension "B" from dimension "A" to get dimension "C".
26. Dimension "C" should be 0.0060-0.0139 in (0.153-0.353 mm). If dimension is not correct, a shim is required. If the dimension is correct, proceed to step 29.
27. If a shim is required, select appropriate shim from list below:

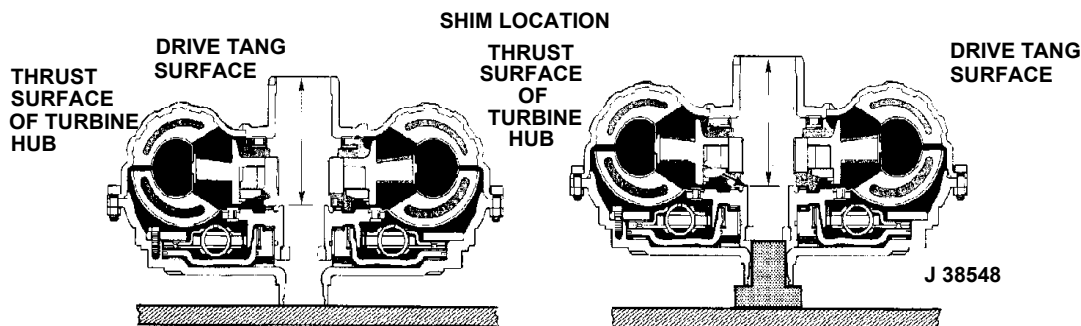

402-608

Dimension C	Use P/N	Shim Thickness
0.0140-0.0229 inch (0.356-0.581 mm)	29503879	0.009-0.011 inch (0.23-0.27 mm)
0.0230-0.0319 inch (0.585-0.810 mm)	29503880	0.018-0.020 inch (0.46-0.50 mm)
0.0320-0.0394 inch (0.813-1.000 mm)	29503881	0.027-0.029 inch (0.69-0.73 mm)

28. Disassemble torque converter and install selected shim. Repeat step 22 through 27 to confirm dimension "C".
29. Install remaining 32 nuts (1) and tighten to 22-26 lb-ft (30-35 Nm).

**MODULE OVERHAUL - CONTINUED****Torque Converter Housing Module Disassembly**

1. Remove ten bolts (11), PTO cover (10), and gasket (9). Discard gasket.
2. Remove 11 bolts (1) securing bearing retainer assembly (2) and PTO gear (12) assembly to converter housing (8).
3. Remove seal rings (3 and 4) from bearing retainer (2). Discard seal rings.
4. Remove bearing retainer oil seal (15) using tool (J24171-A). Discard oil seal.
5. Inspect bushing (14) for damage or wear. Maximum allowable bushing ID is 3.511 in (89.19 mm). Remove if damaged or worn.
6. Remove oil pump drive hub (5) from PTO gear (12).
7. Inspect oil pump drive hub (5) for excessive wear on drive tangs. Maximum allowable tang wear is 0.012 in (0.31 mm).
8. Remove seal ring (7) from PTO gear (12).
9. Inspect PTO gear bearings (6 and 13). If damaged, remove and discard.

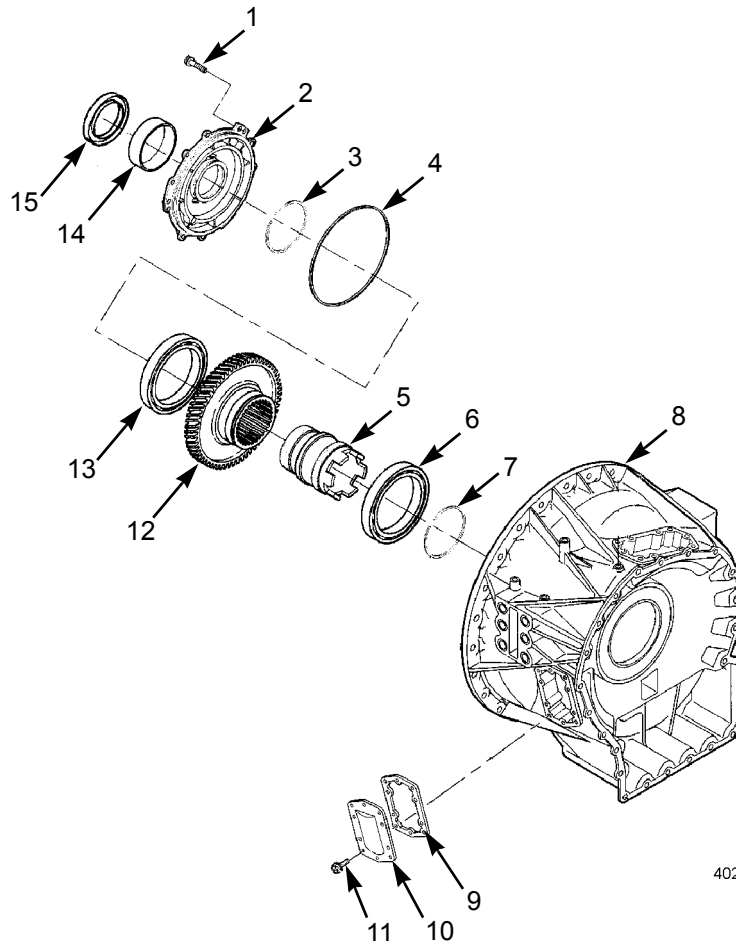

402-609

**MODULE OVERHAUL - CONTINUED****Torque Converter Housing Module Assembly**

1. If PTO gear bearings (6 and 13) were discarded, install new bearings using tool (J37041).

**CAUTION**

Oil pump drive hub can be incorrectly installed backwards. Position oil pump drive hub tangs toward oil pump.

2. Install oil pump drive hub (5) into PTO gear (12), aligned with hub tangs toward oil pump.

**NOTE**

Butt-joint seal rings require special handling during assembly. Seal rings contain materials that absorb moisture from atmosphere, causing them to expand. Check seal ring end clearance before installation to ensure seal ring has not expanded.

3. Install seal ring (7) into seal ring bore of torque converter pump housing and measure end gap with feeler gage. Seal ring end gap must be 0.047-0.065 in (1.19-1.65 mm). If seal ring is not within tolerance, ring has expanded and must be replaced.
4. Remove seal ring (7) from pump housing seal ring bore and install onto PTO gear (12).
5. If removed, install bearing retainer bushing (14) using press and tools (J37038 and J8092).
6. Install new seal ring (4) onto bearing retainer (2) and install new oil seal (15) using press and tools (J37032 and J37034).
7. Install new seal ring (3) into seal ring bore in PTO gear (12) and measure end gap with thickens gage.
8. Seal ring (3) end gap must be 0.047-0.065 in (1.19-1.65 mm). If seal ring is not within tolerance, ring has expanded and must be replaced.
9. Remove seal ring (3) from seal ring bore in PTO gear (12) and install seal ring onto bearing retainer (2).
10. Using a mallet, lightly tap PTO gear (12) assembly into converter housing (8) until gear assembly is seated.
11. Use guide bolts to install bearing retainer assembly (2), rocking retainer while installing into converter housing (8).
12. Install 11 bolts (1) to secure bearing retainer assembly (2) and PTO gear (12) assembly into converter housing (8). Tighten bolts to 38-45 lb-ft. (51-61 Nm).
13. Install PTO cover (10) and new gasket (9) with ten bolts (11). Tighten bolts to 38-45 lb-ft (51-61 Nm).



**MODULE OVERHAUL - CONTINUED****Front Support and Charging Oil Pump Module Disassembly**

1. Remove three seal rings (4) from hub of front support assembly (3).
2. Remove eight bolts (5) securing pump housing assembly (1) to front support assembly (3).
3. Remove pump housing assembly (1) and gear set (2) from front support (3).

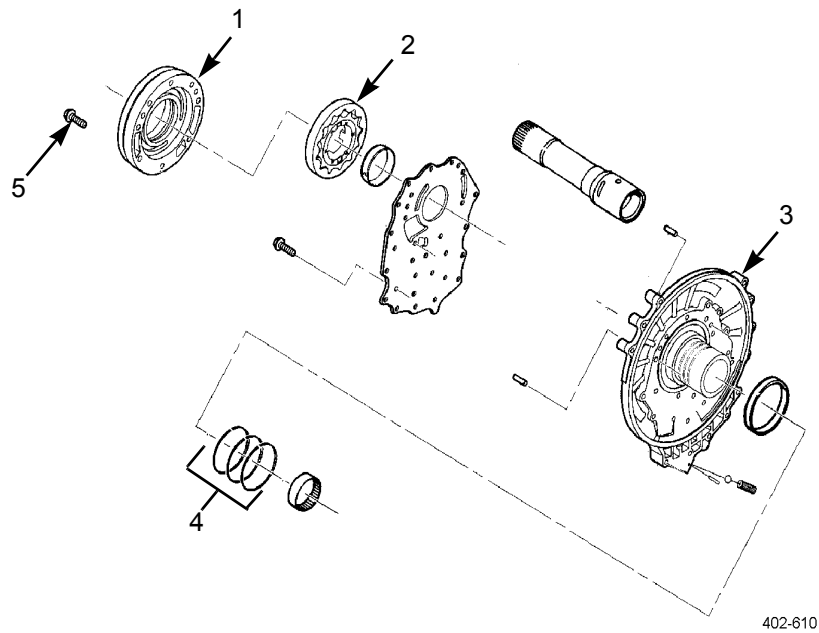

4. Measure gear cavity depth of pump housing. Maximum depth allowed is 0.75 in (19.04 mm).

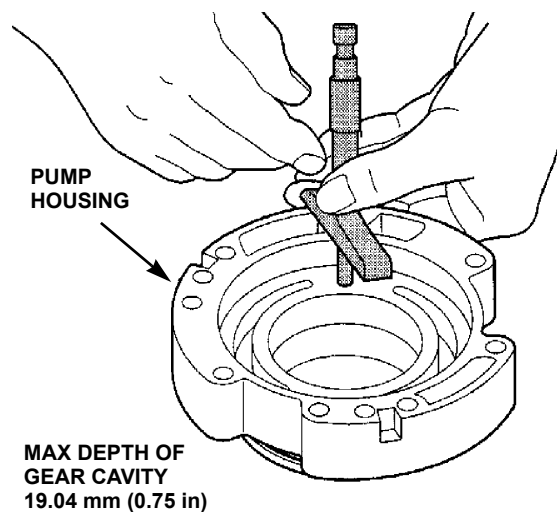

**MODULE OVERHAUL - CONTINUED**

**Front Support and Charging Oil Pump Module Disassembly - Continued**

5. Measure gear cavity diameter of pump housing (1). Maximum depth allowed is 5.915 in (150.25 mm).

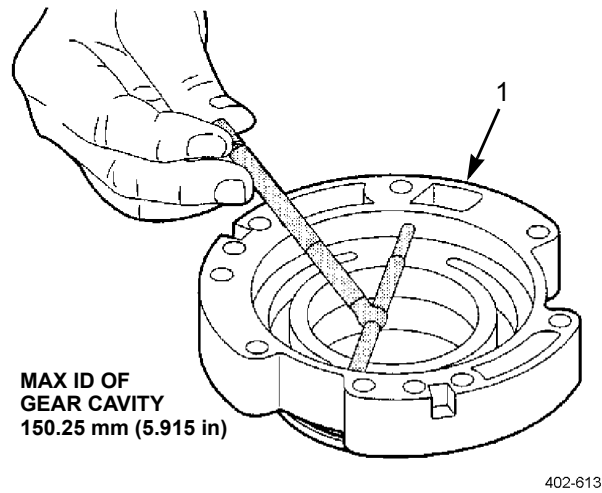

6. Install gear set (2) into pump housing (1). Measure pump gear side clearance of both gears. Maximum allowable clearance is 0.004 in (0.10 mm).

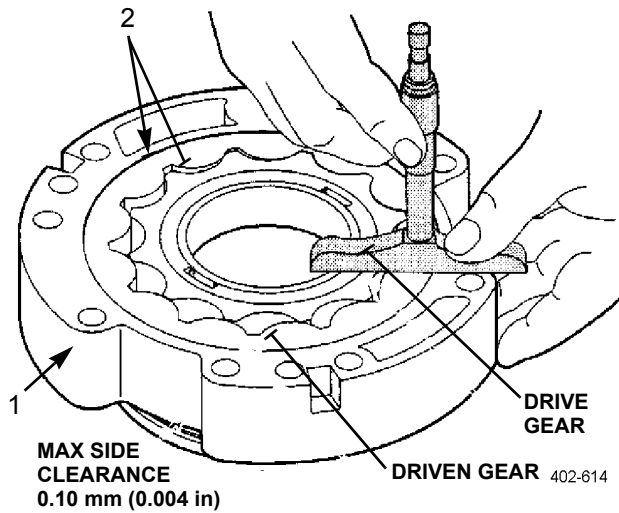

**MODULE OVERHAUL - CONTINUED****Front Support and Charging Oil Pump Module Disassembly - Continued**

7. Measure gear tooth tip clearance. Maximum allowable clearance is 0.006 in (0.15 mm).

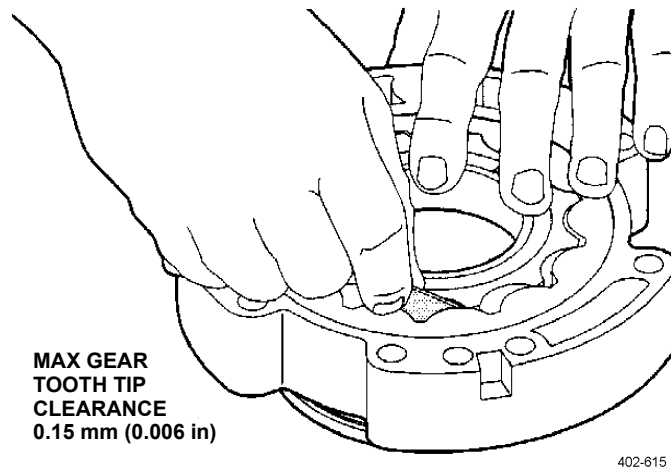

8. Measure driven gear to pump housing clearance. Maximum allowable clearance is 0.012 in (0.30 mm).

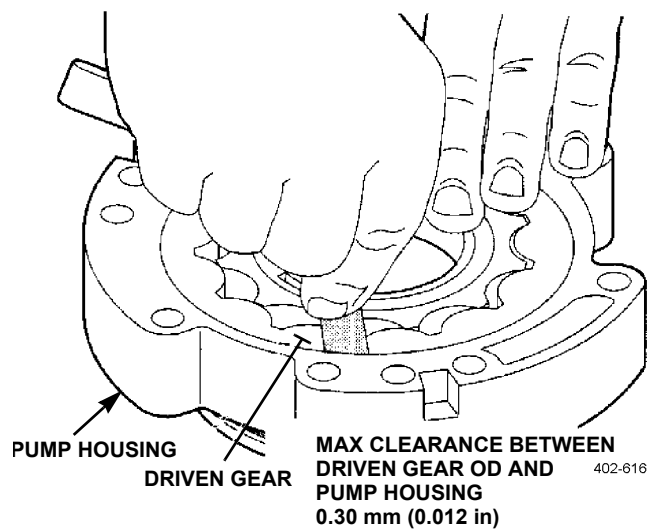

9. Inspect and measure bushing (6) inside inner gear of gear set (2). The maximum ID of bushing is 2.635 in (66.93 mm). If bushing is damaged or out of tolerance, remove.
10. Remove 14 bolts (16) securing wear plate (15) to front support (3). Remove wear plate.
11. Inspect roller bearing (14). If damaged, remove using drift and hammer.
12. Inspect and measure front support sleeve (9). Minimum OD diameter of front support sleeve is 4.717 in (119.81 mm). If sleeve is damaged or out of tolerance, remove.
13. Inspect front support dowel pins (8 and 13). If damaged, remove.

**MODULE OVERHAUL - CONTINUED****Front Support and Charging Oil Pump Module Disassembly - Continued**

14. Inspect ground sleeve (7). If damaged or worn, press from front support (3).
15. Using tool (J41462), compress spring (10) until load is removed from dowel pin (12). Remove dowel pin and carefully release load on spring by rotating handle on tool in counterclockwise direction. When spring has reached its free length, remove tool. Remove spring and ball (11) from front support (3). Check spring tension in accordance with Table 3, Wear Limits and Spring Data, located at the end of this work package.
16. Inspect ball seat area of front support (3) for damage. If damage is found, replace front support.

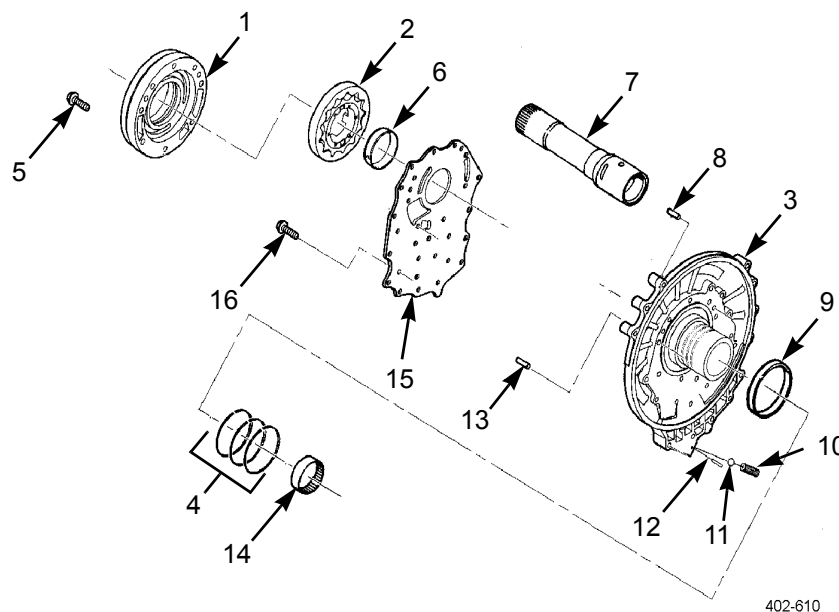

402-610

**Front Support and Charging Oil Pump Module Assembly**

1. Install ball (11) and spring (10) into front support (3). Compress spring using tool (J41462) until dowel pin (12) can be inserted to retain spring. Remove tool.
2. Install ground sleeve (7) on front support (3). Press sleeve into front support with machined surface at base of sleeve aligned with arrow cast on front support. Total runout of spline OD may not exceed 0.005 in (0.13 mm).
3. If removed, install dowel pins (8 and 13) in front support (3). Press pins to a height of 0.57 in (14.5 mm) from surface of front support.
4. Install front support sleeve (9) into front support (3), with lubrication hole aligned with relief valve bore.
5. Using a press and tools (J37041 and J37034), install wear plate (15) to front support (3) with 14 bolts (16). Tighten bolts to 38-45 lb-ft (51-61 Nm).
6. If removed, install roller bearing (14) to front support (3) using a press and tools (J37038). Press roller bearing flush to 0.010 in (0.25 mm) below surface.
7. Install gear pump bushing (6) into inner gear of gear set (2). Align staking in pre-staked bushing with slots inside gear of gear set, using tool (J39954).
8. Lubricate gear set (2) with transmission oil and install gear set in pump housing (1).

**MODULE OVERHAUL - CONTINUED**

**Front Support and Charging Oil Pump Module Assembly - Continued**

- Secure pump housing (1) to front support (3) with eight bolts (5). Tighten bolts to 38-45 lb-ft. (51-61 Nm).

**NOTE**

Butt-joint seal rings require special handling during assembly. Seal rings contain materials that absorb moisture from atmosphere, causing them to expand. Check seal ring end clearance before installation to ensure seal ring has not expanded.

- Measure end gap of three rotating seal rings (4) before installation. Insert seal rings into the rotating clutch hub bore of front support (3) and measure end gap with a thickness gage. Seal ring end gap must be 0.040-0.057 in (1.00-1.44 mm).
- Install three rotating seal rings (4) on front support hub.

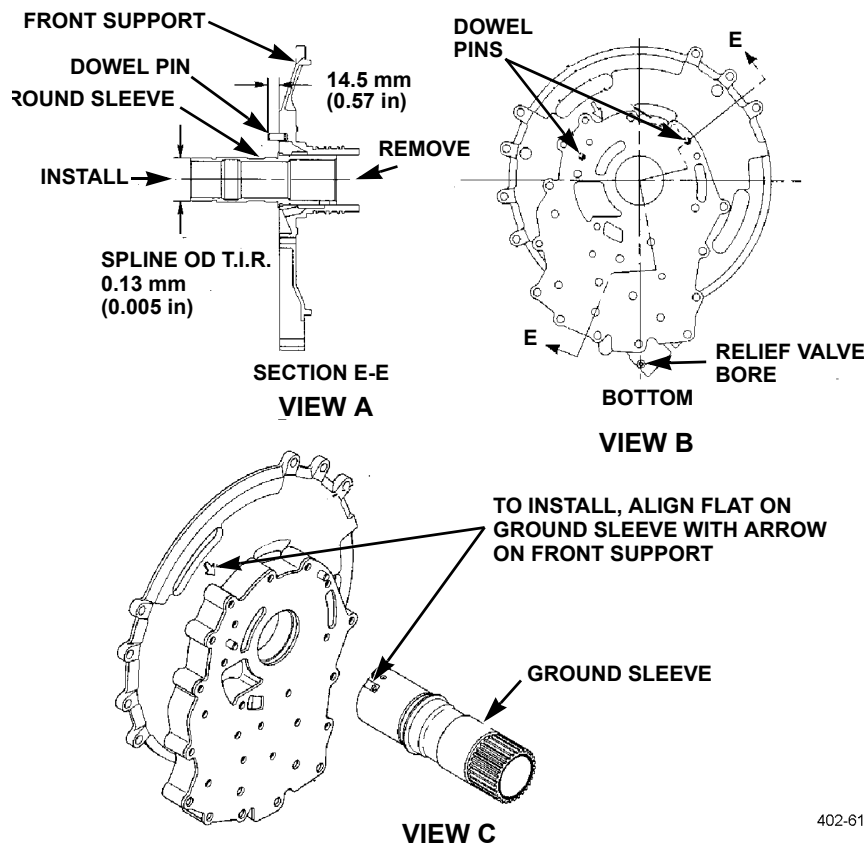

402-617

**MODULE OVERHAUL - CONTINUED**

**Rotating Clutch Module Disassembly**

1. Remove thrust bearing (5) and retaining ring (19) from rotating clutch module (9). Inspect thrust bearing. If worn, discard.
2. Remove P1 sun gear assembly (21) and thrust bearing (20) from rotating clutch module (9).
3. Remove C2 retaining ring (22) and backplate (23).
4. Measure wear surface thickness of C2 backplate (23). Minimum thickness allowed is 0.311 in (7.90 mm). Check flatness of backplate. Maximum allowable distortion is 0.006 in (0.15 mm).

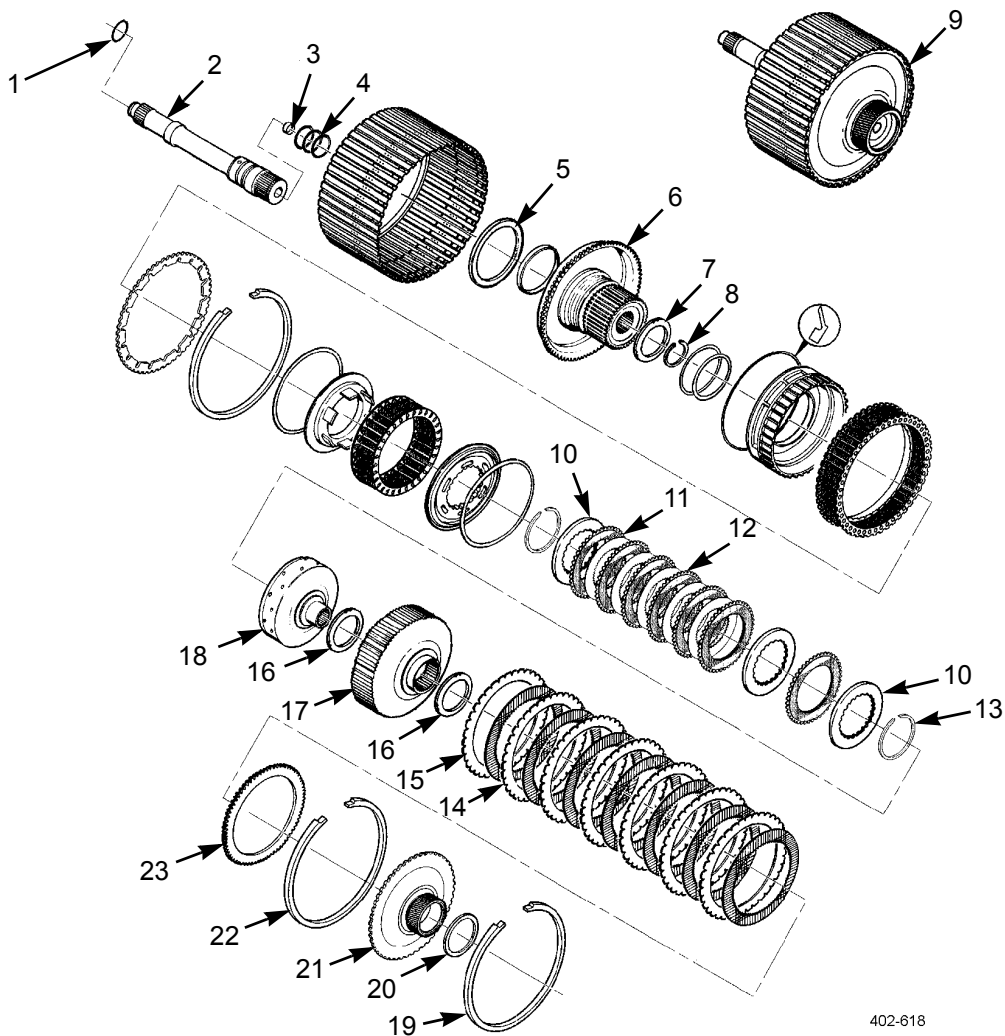

402-618

5. Remove C2 clutch pack containing seven friction plates (14) and seven steel reaction plates (15). Perform the following measurements:
  - a. Friction plate thickness: minimum thickness allowed is 0.115 in (2.92 mm).
  - b. Friction plate oil groove depth: minimum depth allowed is 0.008 in (0.20 mm).
  - c. Friction plate cone: maximum cone allowed is 0.010 in (0.25 mm).

**MODULE OVERHAUL - CONTINUED****Rotating Clutch Module Disassembly - Continued**

- d. Reaction plate thickness: minimum thickness allowed is 0.095 in (2.41 mm).
- e. Reaction plate cone: maximum cone allowed is 0.010 in (0.25 mm).
6. Remove C2 (17) and C1 (18) drive hubs with two thrust bearings (16). Measure drive hub splines. Maximum allowable spline wear is 0.015 in (0.38 mm).
7. Remove C1 retaining ring (13), two backplates (10), seven friction plates (11), and six steel reaction plates (12). Perform the following measurements:
  - a. Friction plate thickness: minimum thickness allowed is 0.115 in (2.92 mm).
  - b. Friction plate oil groove depth: minimum depth allowed is 0.008 in (0.20 mm).
  - c. Friction plate cone: maximum cone allowed is 0.010 in (0.25 mm).
  - d. Reaction plate thickness: minimum thickness allowed is 0.095 in (2.41 mm).
  - e. Reaction plate cone: maximum cone allowed is 0.010 in (0.25 mm).
  - f. Backplate thickness: minimum thickness allowed is 0.311 in (7.90 mm).
  - g. Backplate flatness: maximum allowable distortion is 0.006 in (0.15 mm).
8. Remove thrust bearing (7) from clutch hub assembly (6).
9. Remove retaining ring (8) and turbine shaft (2) from clutch hub (6).
10. Inspect and measure bushing (3) inside end of turbine shaft (2). Maximum ID allowed is 1.423 in (36.14 mm).
11. Remove three seal rings (4) and O-ring (1) from turbine shaft (2). Discard O-ring.

**MODULE OVERHAUL - CONTINUED**

**Rotating Clutch Module Disassembly - Continued**

**WARNING**

The rotating clutch piston springs are highly compressed and must be properly released. Failure to follow this warning may result in personnel injury.

12. Place rotating clutch (9) on tool base (J37030-3) so rotating drum is supported by tool tangs (View C).
13. Install tool (J35923-2) with bearing, washer, and handle. Tighten tool, compressing C1 balance piston (33) and C1 spring assembly (34). Remove retaining ring (31) (View A).

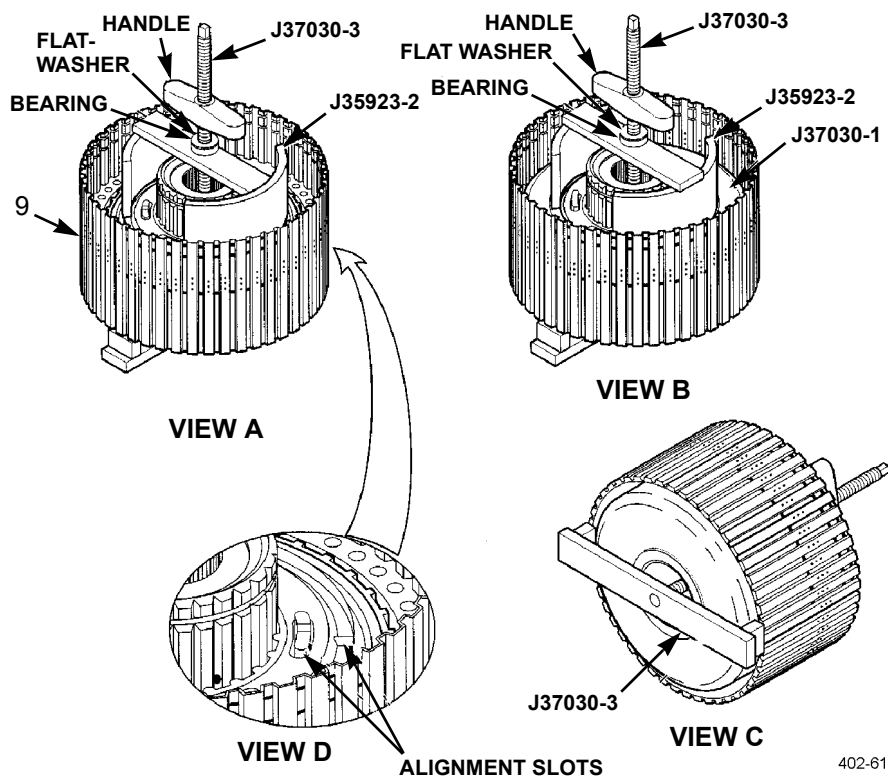

14. Release spring tension by rotating handle in counterclockwise direction. Remove tool (J35923-2) with bearing, washer, and handle.
15. Remove C1 balance piston (33), seal ring (32), and C1 spring assembly (34).
16. Install tools (J37030-3, J37030-1, and J35923), bearing, washer, and handle. Tighten tool and remove retaining ring (37). Remove tools after relieving spring tension. Remove spring assembly (30) and spring plate (38) (View B).



**MODULE OVERHAUL - CONTINUED**

**Rotating Clutch Module Disassembly - Continued**

17. Lift rotating drum (24) from clutch hub (6) and C1/C2 pistons (29 and 35). Inspect clutch splines of rotating drum. Maximum spline wear allowed is 0.015 in (0.38 mm).
18. Remove C1/C2 pistons (29 and 35) and seal rings (28 and 36) from clutch hub (6), by rocking pistons from side to side.
19. Inspect and measure ID of rotating clutch hub housing bushing (25). Maximum allowable ID of bushing is 4.735 in (120.27 mm). Remove bushing from clutch hub (6) if replacement is necessary. Avoid damaging bushing bore.
20. Remove piston seal rings (26 and 27) from clutch hub (6).
21. Separate C1 piston (35) and seal ring (36) from C2 piston (29) and seal ring (28) by lightly tapping on C1 piston.

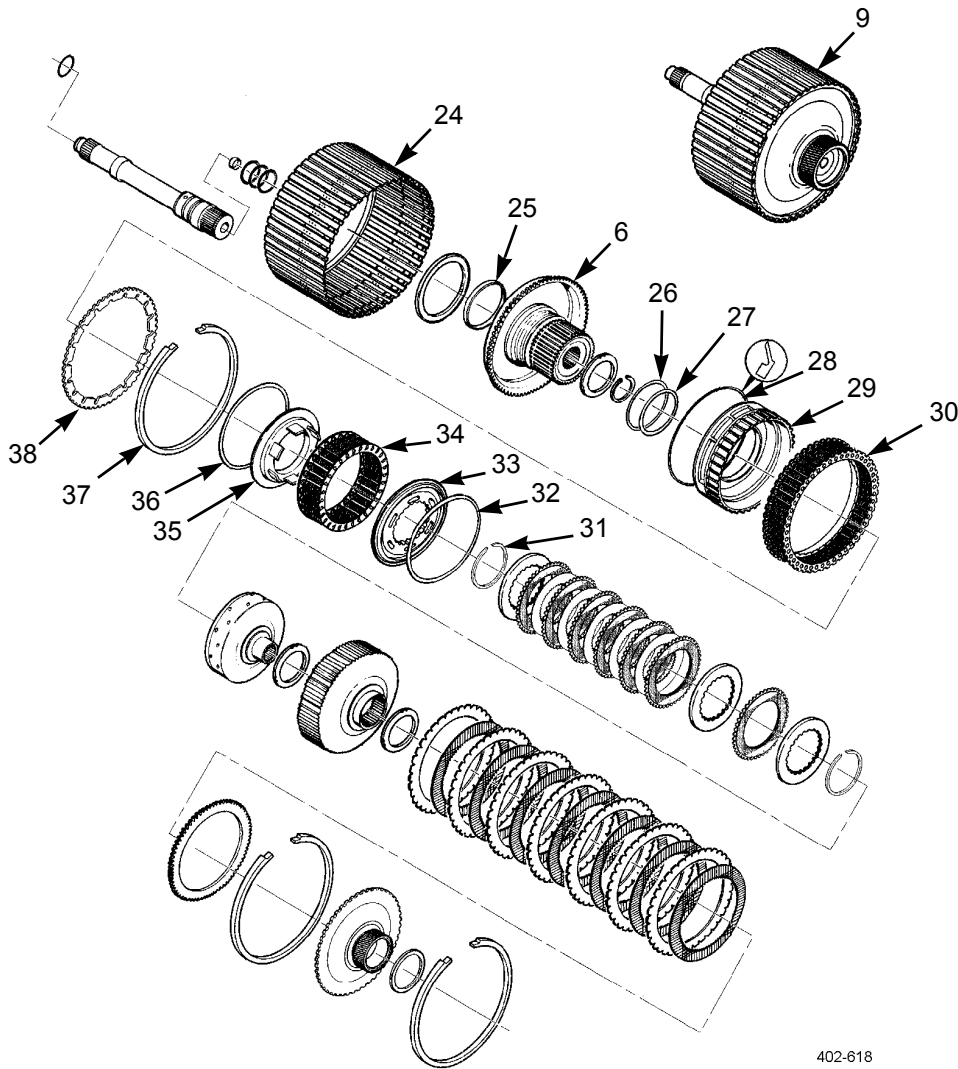

402-618

**MODULE OVERHAUL - CONTINUED****Rotating Clutch Module Assembly**

1. If rotating clutch hub bushing (25) was removed, install new bushing using tool (J37040).
2. Install piston seal ring (26) on clutch hub (6), and piston seal ring (27) into C2 piston (29). Install clutch hub and piston seal ring (36) into C1 piston (35).
3. With a mallet, lightly tap C2 piston (29) into clutch hub (6).
4. Align notch on C1 piston (35) with lubrication orifice on rotating drive hub. With a mallet, lightly tap C1 piston onto center of C2 piston (29) and over clutch hub (6).
5. Install rotating drum (24) over clutch hub (6) and C1/C2 pistons (29 and 35).
6. Install C2 spring assembly (30). Index spring assembly with drive hub tangs and splines on C2 piston (29). Ensure C2 spring assembly has made contact with bottom of slots in C2 piston. If spring assembly did not reach bottom, remove spring assembly and reannex in next spline on rotating drum. Repeat this process until C2 spring is in proper position.
7. Install C2 spring plate (38). Index spring plate with drive hub tangs and splines on C2 piston (29).

**WARNING**

The rotating clutch piston springs are highly compressed and must be properly released. Failure to follow this warning may result in personnel injury.

8. Place rotating clutch on tool base (J37030-3) so that rotating drum is supported by tool tangs. Install tool (J37030-1 and J35923-2), that includes bearing, washer, and handle. Tighten tool to compress C2 spring assembly (30) and install retaining ring (37) (View B, page 0083 00-24). Remove tools.
9. Install seal ring (32) onto balance piston (33).
10. Install C1 spring assembly (34). Align mark on balance piston (33) with slot on C1 piston (35). Position balance piston onto the C1 piston.
11. Install tool (J35923-2) with bearing, washer, and handle. Tighten tool, compressing C1 balance piston (33) and C1 spring assembly (34). Install retaining ring (31) (View A, page 0083 00-24). Remove tools.
12. If turbine shaft bushing (3) was removed, replace using tool (J37036).
13. Lubricate with transmission oil and install new O-ring (1) on turbine shaft (2).

**NOTE**

Butt-joint seal rings require special handling during assembly. Seal rings contain materials that absorb moisture from atmosphere causing them to expand. Check seal ring end clearance before installation to ensure seal ring has not expanded.

14. Install each rotating seal ring (4) into ground sleeve bore and measure end gap. Seal ring end gap must be 0.026-0.040 in (0.65-1.01 mm). Install three rotating seal rings with correct end gap, into rear of turbine shaft (20).
15. Install turbine shaft (2) and retain with retaining ring (8).

**CAUTION**

Ensure thrust bearing is assembled with locating lip on either inner or outer thrust bearing race not preventing race from contacting thrust surface of mating part. Failure to follow this caution leads to thrust bearing failure and incorrect shim selection to maintain proper part clearance.

16. Install thrust bearing (7) on rotating clutch hub (6).

**MODULE OVERHAUL - CONTINUED**

**Rotating Clutch Module Assembly - Continued**

17. Install C1 clutch pack: first install one backplate (10), then alternately install friction (11) and steel reaction plates (12), starting with a friction plate and ending with a backplate. Secure clutch pack in place with retaining ring (13).
18. Install C1 drive hub (18) over clutch pack while aligning external splines.
19. Install thrust bearing (16) on each side of C2 drive hub (17), then position this group over C1 drive hub (18).
20. Install C2 clutch plates, alternating between friction plates (14) and steel reaction plates (15), starting with steel reaction plates.
21. Install C2 backplate (23) and retaining ring (22).
22. Install thrust bearing (20) on sun gear (21).
23. Install P1 sun gear assembly (21) and retaining ring (19).
24. Install thrust bearing (5) on rotating clutch module (9).

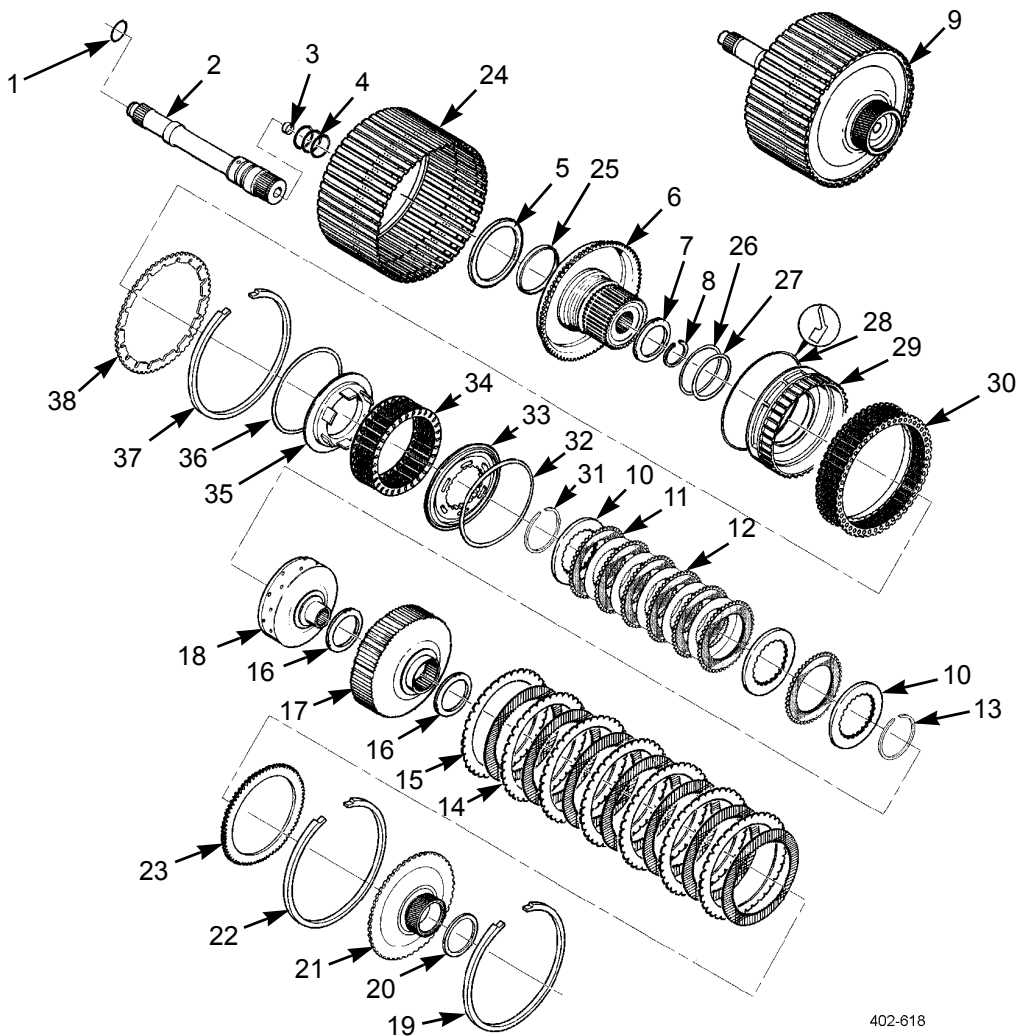

402-618

**MODULE OVERHAUL - CONTINUED****C3/C4 Clutch Assembly and Main Housing Module Disassembly**

1. Remove 14 bolts (1) securing C3/C4 clutch assembly (5).
2. Remove C3 backplate assembly (2) from clutch assembly (5)
3. Inspect and measure four thrust plates (4), backplate (2), and check 12 rivets (3) on clutch backplate. Perform the following measurements:
  - a. Thrust plate thickness at contact surface: minimum allowable thickness is 0.1109 in (2.818 mm).
  - b. Backplate distortion: maximum allowable distortion is 0.006 in (0.15 mm).
  - c. Backplate step wear: maximum allowable wear is 0.005 in (0.13 mm).If replacement is necessary, remove thrust plates (4) by drilling out rivets (3).
4. Remove P1 ring gear (6) and inspect clutch splines of P1 ring gear. Maximum allowable spline wear is 0.015 in (0.38 mm).
5. Remove and measure C3 clutch pack: five friction plates (7) and four steel reaction plates (8). Perform the following measurements:
  - a. Friction plate thickness: minimum allowable thickness is 0.137 in (3.48 mm).
  - b. Friction plate: maximum allowable cone is 0.010 in (0.25 mm).
  - c. Steel reaction plate thickness: minimum allowable thickness is 0.095 in (2.41 mm).
  - d. Steel reaction plate: maximum allowable cone is 0.016 in (0.40 mm).
6. Remove piston return plate (10) with four return springs assemblies (9) attached.
7. Inspect and measure piston return plate (10). Minimum allowable thickness of plate is 2.162 in (54.91 mm).
8. If return spring assemblies (9) are damaged and require replacement, remove them from piston return plate (10) by separating spring retainer (11) from piston (14).
9. Remove seal rings (12 and 13) from piston (14). Discard seal rings.
10. Remove C3 clutch housing assembly (17) from C3/C4 clutch assembly (5).
11. Inspect and measure four thrust plates (15) on C3 clutch housing (17). Perform the following measurements:
  - a. Thrust plate thickness at contact surface: minimum allowable thickness is 0.1109 in (2.818 mm).
  - b. Backplate distortion: maximum allowable distortion is 0.006 in (0.15 mm).
  - c. Backplate step wear: maximum allowable wear is 0.005 in (0.13 mm).
  - d. Clutch housing splines: maximum allowable wear is 0.045 in (1.15 mm)If replacement is necessary, remove thrust plates (15) by drilling out 12 rivets (16).
12. Remove and measure C4 clutch pack: five friction plates (25) and five steel reaction plates (26). Perform the following measurements:
  - a. Friction plate thickness: minimum allowable thickness is 0.137 in (3.48 mm).
  - b. Friction plate: maximum allowable cone is 0.010 in (0.25 mm).
  - c. Steel reaction plate thickness: minimum allowable thickness is 0.095 in (2.41 mm).
  - d. Steel reaction plate: maximum allowable cone is 0.010 in (0.25 mm).
13. Remove piston return plate (23) with four return springs assemblies (24) attached.
14. Inspect and measure piston return plate (23). Minimum allowable thickness of plate is 2.162 in (54.91 mm).

**MODULE OVERHAUL - CONTINUED****C3/C4 Clutch Assembly and Main Housing Module Disassembly - Continued**

15. If return spring assemblies (24) are damaged and require replacement, remove them from piston return plate (23) by separating spring retainer (22) from piston (19).
16. Remove seal rings (20 and 21) from piston (19). Discard seal rings.
17. Inspect and measure C4 clutch housing (18). Maximum spline wear allowed is 0.045 in (1.15 mm).

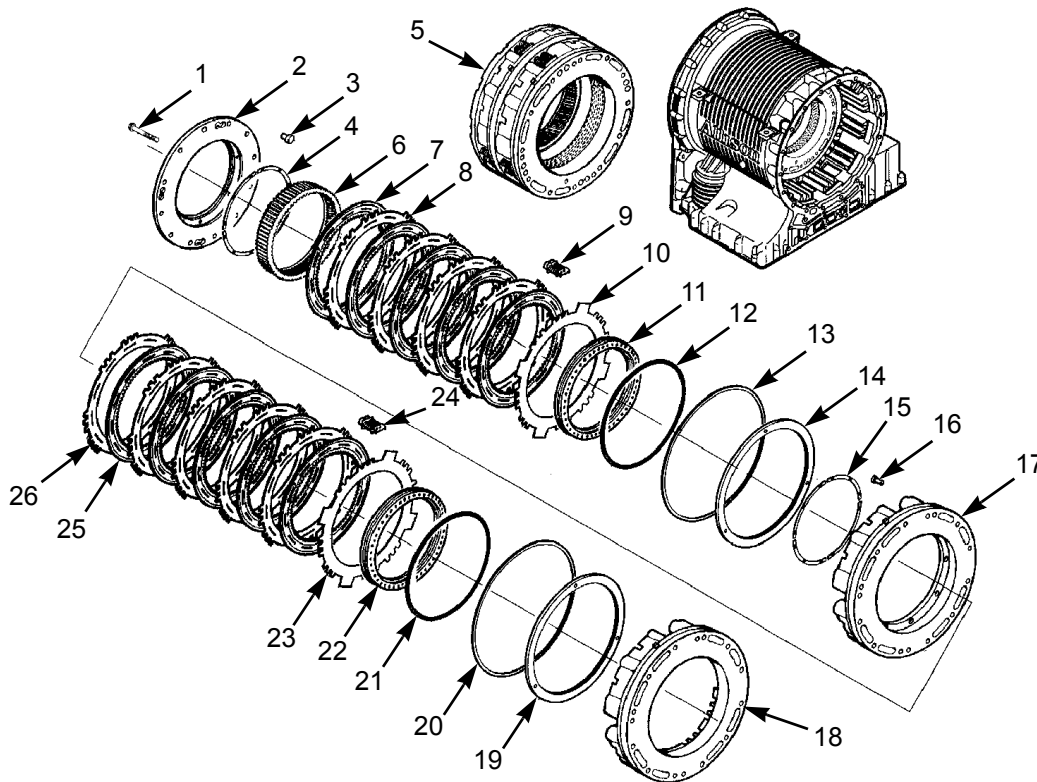

402-620

**MODULE OVERHAUL - CONTINUED****C3/C4 Clutch Assembly and Main Housing Module Assembly**

1. Install new seal rings (20 and 21) on piston (19). Install piston with seal rings into C4 housing (18).
2. Install spring retainer (22) on piston (19) and in C4 housing (18).
3. If removed, install new return spring assemblies (24) and attach them securely to piston return plate (23).
4. Install piston return plate (23) with return spring assemblies (24) into C4 clutch housing (18).
5. Install C4 clutch pack, starting with a friction plate (25). Alternately install five friction plates and five steel reaction plates (26).

**NOTE**

Perform step 6 only if C3 clutch housing was disassembled. If clutch housing was not disassembled, proceed to step 7.

6. Install four thrust plates (15) using 12 rivets (16) into C3 clutch housing (17). Use tool (J39534) to cold form rivets. Insert rivet from front so that preformed head is below active surface of thrust plate. Use cold forming tool to upset rivet at rear of clutch housing to complete riveted joint. A correctly formed rivet upset will be 0.157 in (4.00 mm) in diameter and no more than 0.039 in (1.00 mm) above surface of clutch housing. Thrust plate must be tightly attached to housing; no movement is allowed.
7. Install new seal rings (12 and 13) on piston (14). Install piston with seal rings into C3 clutch housing (17).
8. Install C3 clutch housing assembly (17) on top of assembled C4 clutch housing assembly (18). Ensure index notches on clutch housings are aligned.
9. Install spring retainer (11) on piston (14) and in C3 clutch housing (17).
10. If removed, install new return spring assemblies (9) and attach them securely to piston return plate (10).
11. Install piston return plate (10) with return spring assemblies (9) into C3 clutch housing (17).
12. Install P1 ring gear (6).
13. Install C3 clutch pack: starting with a friction plate (7), alternately install five friction plates and four steel reaction plates (8).

**NOTE**

Perform step number 14 only if C3 backplate was disassembled. If clutch housing was not disassembled, proceed to step number 15.

14. Install four thrust plates (4) using 12 rivets (3) into C3 backplate (2). Use tool (J39534) to cold form rivets. Insert rivet from front so that preformed head is below active surface of thrust plate. Use cold forming tool to upset rivet at rear of backplate to complete riveted joint. A correctly formed rivet upset will be 0.157 in (4.00 mm) in diameter and no more than 0.039 in (1.00 mm) above surface of backplate. Thrust plate must be tightly attached to backplate; no movement is allowed.
15. Install C3 backplate assembly (2), aligning notches on C3 and C4 housings.
16. Install 14 bolts (1) into C3/C4 clutch assembly (5). Tighten bolts to 38-45 ft-lb (51-61 Nm).

MODULE OVERHAUL - CONTINUED

C3/C4 Clutch Assembly and Main Housing Module Assembly - Continued

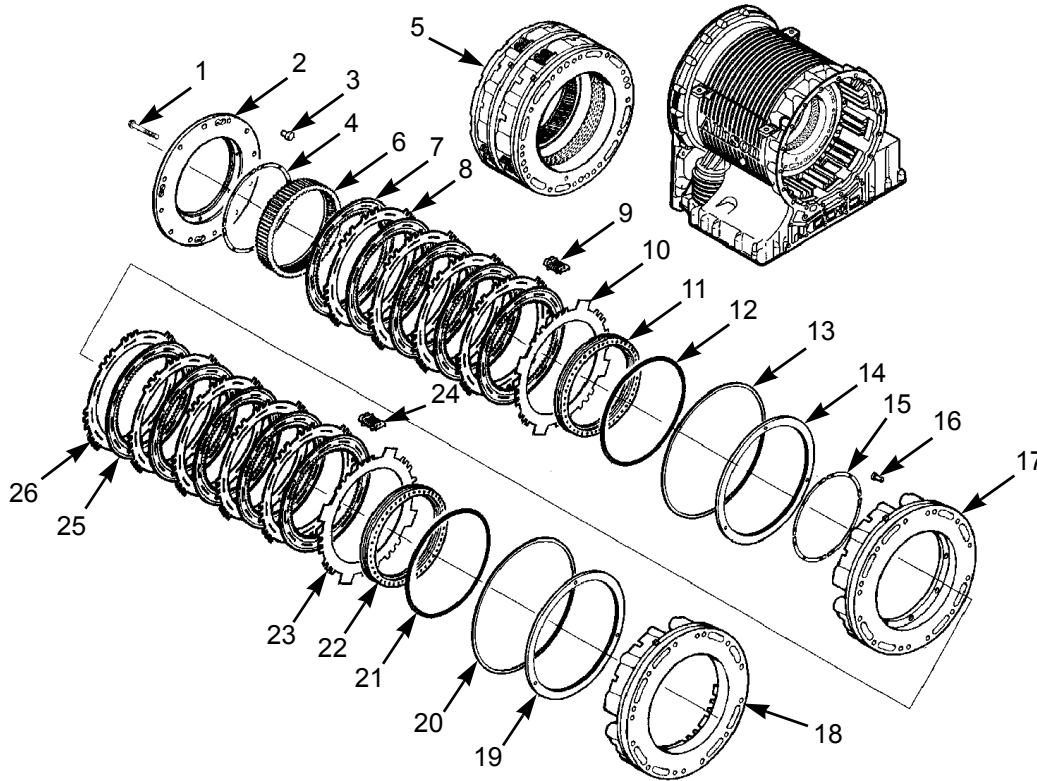

402-620

**MODULE OVERHAUL - CONTINUED****Main Shaft Module Disassembly**

1. Remove external spiral retaining ring (1) and P2 sun gear (2) from main shaft (6).
2. Remove bearing spacer (3), thrust bearing (5), and selective shim (4) from main shaft (6).
3. Inspect and measure main shaft (6). Inspect for evidence of wear, chipped or cracked splines or teeth. Measure main shaft in accordance with Table 2, Wear Limits Data, located at the end of this work package.

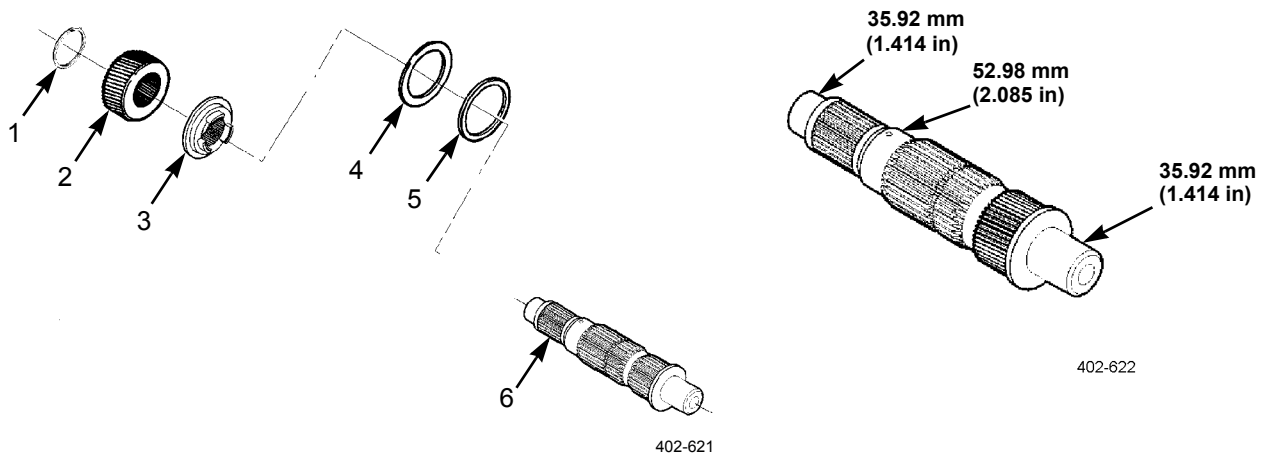
**Main Shaft Module Assembly****NOTE**

Do not install thrust bearing (5) and selective shim (4) until final transmission assembly. Measurement for selective shim is performed during final buildup.

1. Install bearing spacer (3) on main shaft (6).
2. Install P2 sun gear (2) and external spiral retaining ring (1) on main shaft (6).

**P1 Planetary Module Disassembly**

1. Remove internal retaining ring (1) from P2 planetary ring gear (5) and remove P2 planetary ring gear from planetary module (2).
2. Check P1 planetary carrier assembly (3) for pinion end play. Pinion end play must not exceed 0.037 in (0.94 mm). Check all six pinion gears.
3. Remove retaining ring (13) and indexing ring (12).
4. Remove six pinion spindles (11) from P1 planetary carrier (3).
5. Remove pinion gear (9), thrust washers (7 and 10), and two bearing assemblies (8) from side of P1 planetary carrier (3). Repeat procedure for remaining pinion gears.
6. Measure thickness and step wear of thrust washers (7 and 10). Minimum thrust washer thickness allowed is 0.055 in (1.40 mm). Maximum step wear allowed is 0.005 in (0.12 mm).
7. Remove thrust bearing (4) from P1 planetary carrier (3).



**MODULE OVERHAUL - CONTINUED****P1 Planetary Module Disassembly - Continued**

8. Inspect and measure bushing (6) inside P1 planetary carrier (3) for wear or damage. Maximum ID allowed is 3.516 in (89.32 mm). If bushing is worn, remove and replace.
9. Check spline wear of P1 planetary carrier (3) and P2 planetary ring gear (5). Maximum allowed spline wear is 3.015 in (0.38 mm).

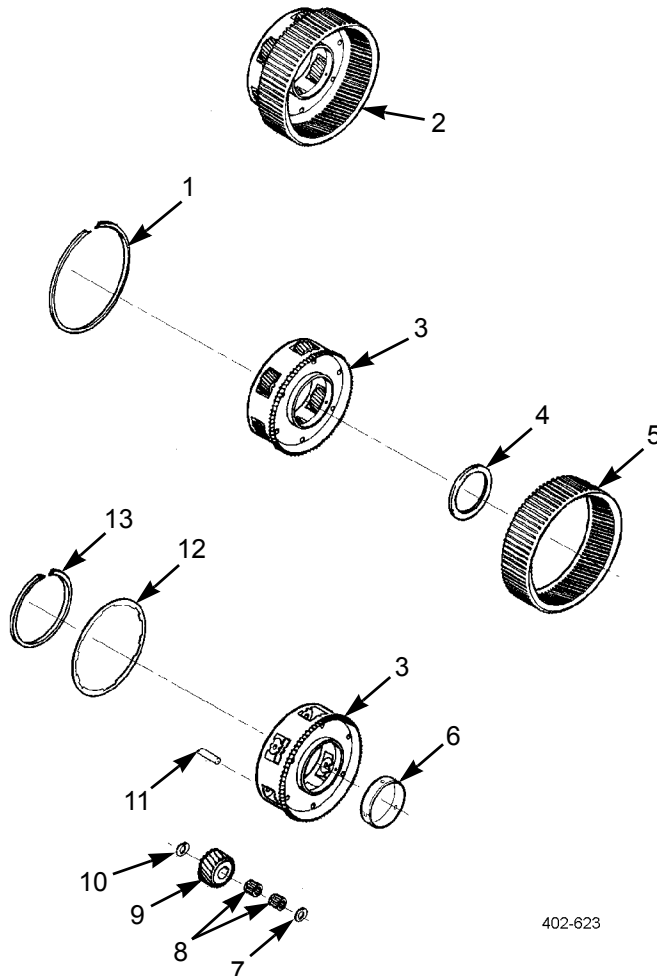

402-623

**P1 Planetary Module Assembly**

1. If removed, install bushing (6) into P1 planetary carrier (3) using a press and tool (J37038). Press new bushing flush to 0.016 in (0.40 mm) below surface.
2. Install two bearing assemblies (8) into center of pinion gear (9). Install thrust washers (7 and 10) inside P1 planetary carrier (3), align thrust washer tangs with slots in planetary, and retain them with petrolatum. Slide pinion gear and bearing assemblies into side of P1 planetary carrier between thrust washers. Repeat procedure for remaining five pinion gears.
3. Install six spindles (11) so that lower step is positioned for proper installation of indexing ring (12).
4. Install indexing ring (12) and retaining ring (13) to secure pinion gears in place.

**MODULE OVERHAUL - CONTINUED**

5. Measure pinion end play. Pinion end play must not exceed 0.037 in (0.94 mm). Check all six pinion gears.
6. Install P2 planetary ring gear (5) over P1 planetary carrier assembly (3).
7. Install internal retaining ring (1) into P2 planetary ring gear (5), connecting P1 planetary carrier assembly (3) and P2 planetary ring gear.

**CAUTION**

Ensure thrust bearing is assembled with locating lip on either inner or outer thrust bearing race not preventing race from contacting thrust surface of mating part. Failure to follow this caution leads to thrust bearing failure and incorrect shim selection to maintain proper part clearance.

8. Install thrust bearing (4) on P1 planetary carrier (3).

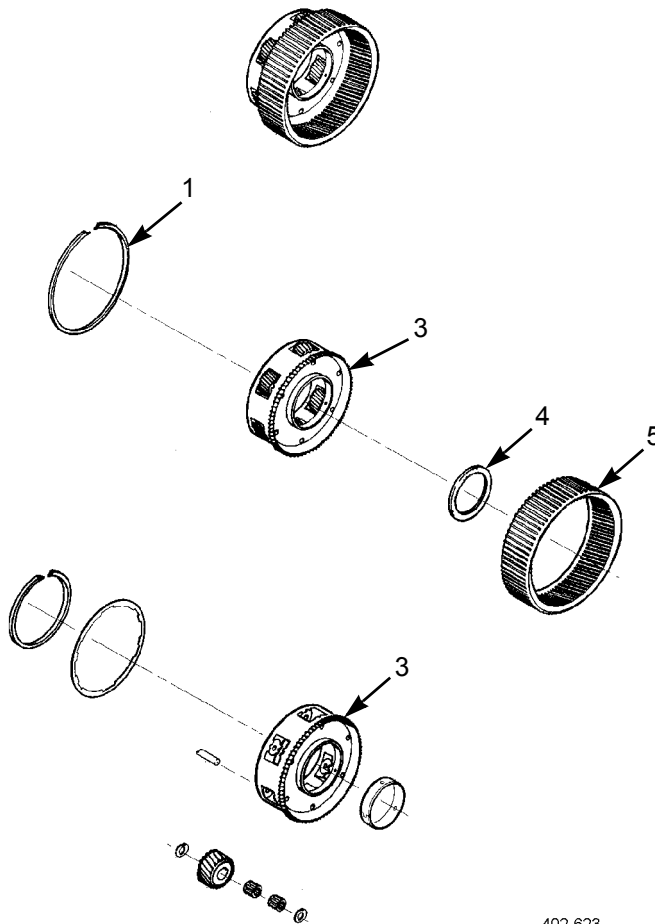

402-623

**MODULE OVERHAUL - CONTINUED****P2 Planetary Module Disassembly**

1. Remove retaining ring (1) and P3 planetary ring gear (4) from planetary module (3). Remove and inspect thrust bearing (5).
2. Check P2 planetary carrier assembly (2) for pinion end play. Pinion end play must not exceed 0.037 in (0.94 mm). Check all six pinion gears.
3. Remove internal retaining ring (13), indexing ring (12), and four pinion spindles (7) from P2 planetary carrier (2).
4. Remove pinion gear (9), thrust washers (8 and 11), and two bearing assemblies (10) from side of P2 planetary carrier (2). Repeat procedure for remaining pinion gears.
5. Measure thickness and step wear of thrust washers (8 and 11). Minimum thrust washer thickness allowed is 0.055 in (1.40 mm). Maximum step wear allowed is 0.005 in (0.12 mm).
6. Inspect and measure bushing (6) inside P2 planetary carrier (2) for wear or damage. Maximum ID allowed is 2.096 in (53.23 mm). If bushing is worn, remove and replace.
7. Check spline wear of P2 planetary carrier (2) and P3 planetary ring gear (4). Maximum allowed spline wear is 0.015 in (0.38 mm).

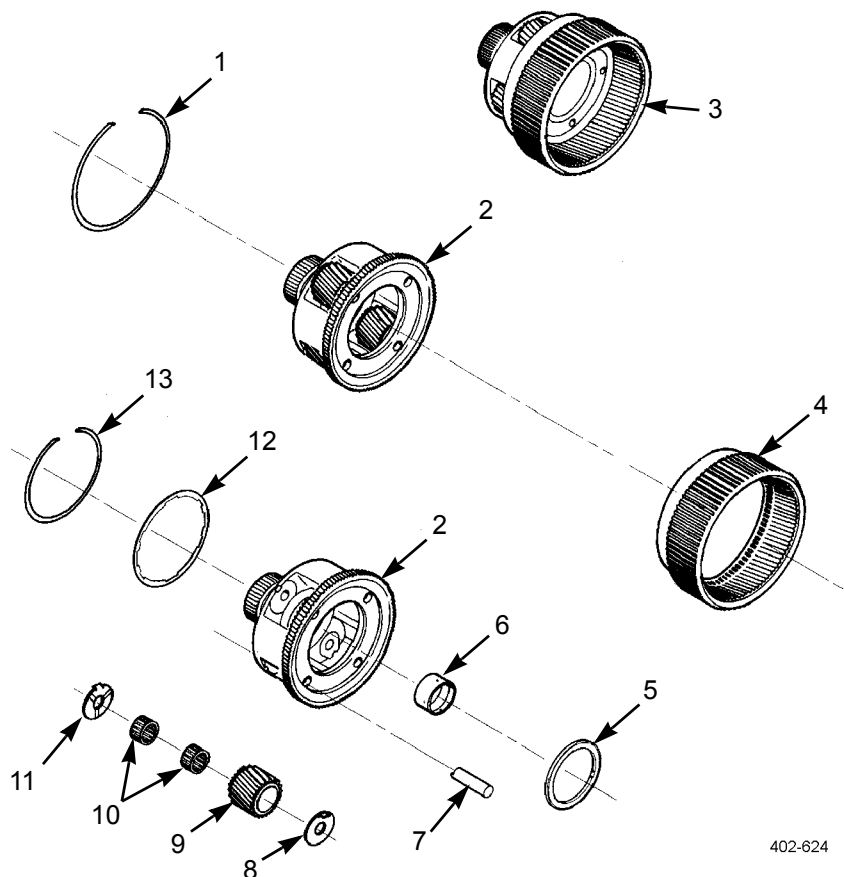

402-624

**MODULE OVERHAUL - CONTINUED****P2 Planetary Module Assembly**

1. If removed, replace bushing (6) into P2 planetary carrier (2) using a press and tool (J37036). Press new bushing flush to 0.016 in (0.40 mm) below surface.
2. Install two bearing assemblies (10) into center of pinion gear (9). Install thrust washers (8 and 11) inside P2 planetary carrier (2), align thrust washer tangs with slots in planetary, and retain them with petrolatum. Slide pinion gear and bearing assemblies into side of P2 planetary carrier between thrust washers. Repeat procedure for remaining five pinion gears.
3. Install four pinion spindles (7) so that lower step is positioned for proper installation of indexing ring (12).
4. Install indexing ring (12) and retaining (13) to secure pinion gears in place.
5. Measure pinion end play. Pinion end play must not exceed 0.037 in (0.94 mm). Check all four pinion gears.
6. Install P3 planetary ring gear (4) over P2 planetary carrier assembly (2).
7. Install retaining ring (1) into P3 planetary ring gear (4) so that P2 planetary carrier and P3 planetary ring gear are assembled.
8. Install thrust bearing (5) on planetary module (3).

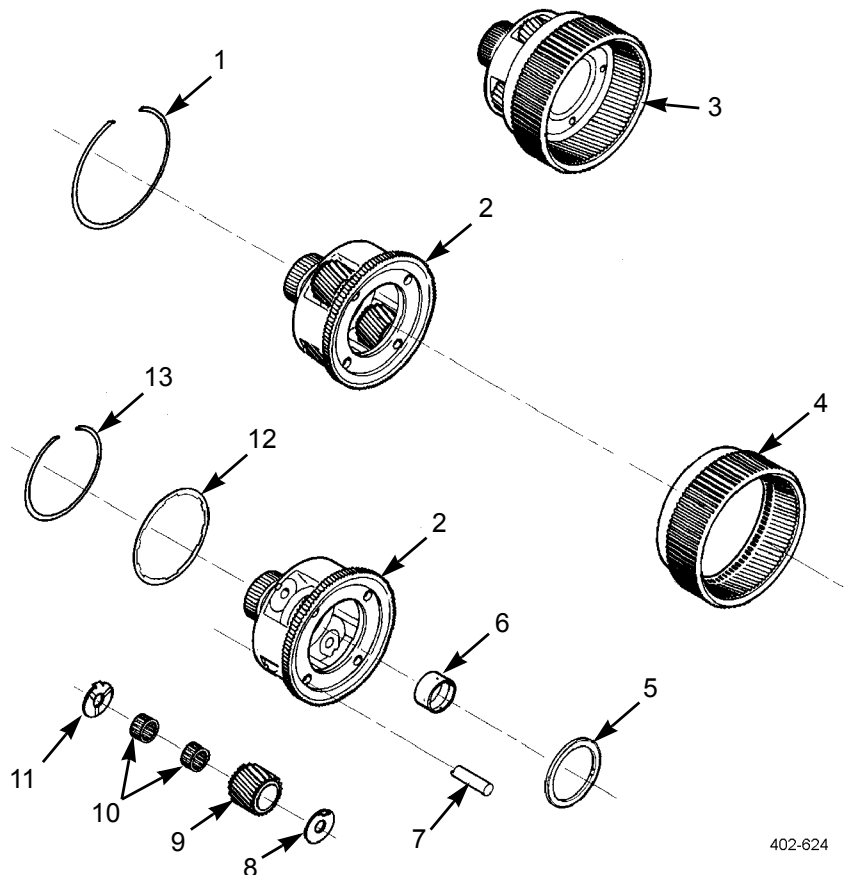

402-624

**MODULE OVERHAUL - CONTINUED****Rear Cover and P3 Planetary Module Disassembly**

1. Straighten tangs of locknut retainer (11) to allow removal of bearing retainer locknut (10). Remove bearing retainer locknut using tool (J37035). Remove locknut retainer.
2. Support rear cover assembly (3) so that P3 planetary carrier assembly (1) can be removed. Place tool (J37035-1) over output shaft splines and against threaded shoulder of P3 planetary carrier. Using a hydraulic press or a mallet, press on tool (J37035-1) to separate planetary carrier from rear cover.
3. Inspect rear cover cone and roller bearing (12). If worn or damaged, remove using tool (J3940).

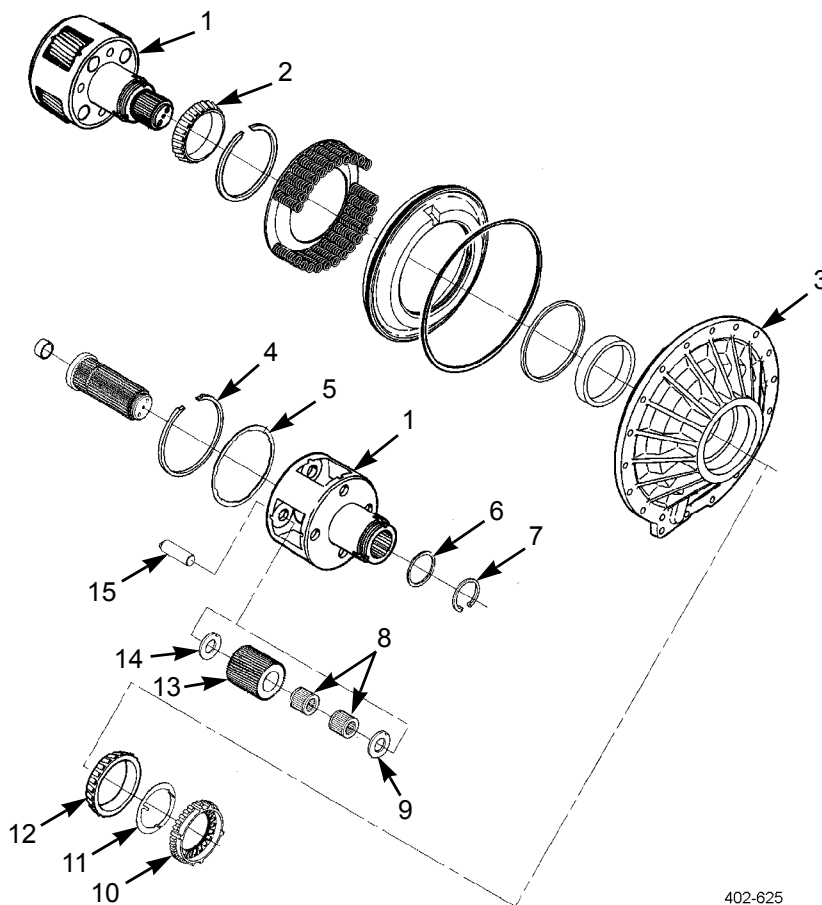

402-625

**WARNING**

Place P3 planetary carrier assembly on its side during disassembly to avoid possible hand injury.

4. Remove retaining ring (7) and thrust washer (6) from P3 planetary carrier assembly (1).
5. Inspect planetary carrier cone and roller bearing (2). If worn or damaged, remove.
6. Remove retaining ring (4), indexing ring (5), and four pinion spindles (15) from P3 planetary carrier (1).
7. Remove pinion gear (13), thrust washers (9 and 14), and two bearing assemblies (8) from side of the P3 planetary carrier (1). Repeat procedures for remaining pinion gears. Measure thickness and step wear of thrust washers. Minimum thrust washer thickness allowed is 0.055 in (1.40 mm). Maximum step wear allowed is 0.005 in (0.12 mm).

**MODULE OVERHAUL - CONTINUED****Rear Cover and P3 Planetary Module Disassembly - Continued**

8. Inspect and measure bushing (23) inside end of output shaft (22) for damage or wear. The maximum ID of bushing is 1.423 in (36.14 mm).

**WARNING**

Rear cover spring and retainer assembly contains highly compressed springs. Be extremely careful during disassembly. Personal injury can occur if spring force is not controlled.

9. Remove C5 clutch piston (18) from rear cover (3) by compressing spring and retainer assembly (17), using tool (J37030-3) tool base, washer, bearing, handle, and piston compressor (J37030-2). Remove retaining ring (19) and slowly release spring force.
10. Remove outer seal ring (20) and inner seal ring (21) from C5 clutch piston (18).
11. Inspect bearing cup (16). If worn or damaged, remove using tool (J3940).

**Rear Cover and P3 Planetary Module Assembly**

1. If removed, install new bearing cup (16), using bearing tool (J37033) and drive sleeve tool (J37034).
2. Install inner seal ring (21) and outer seal ring (20) onto C5 clutch piston (18).
3. Align tang notch on rear of C5 clutch piston (18) with tang in rear cover (3), while installing C5 clutch piston into rear cover.
4. Install spring and retainer assembly (17) while aligning tab in spring and retainer assembly with notch in rear cover (3).

**WARNING**

Rear cover spring and retainer assembly contains highly compressed springs. Be extremely careful during assembly. Personal injury can occur if the spring force is not controlled.

5. Compress spring and retainer assembly (17) using (J37030-3) tool base, washer, bearing, handle, and piston spring compressor (J37030-2). Install retaining ring (19) and slowly release spring force.
6. If removed, install cone and roller bearing (2). Use driver sleeve tool (J37034) and press bearing against shoulder on P3 planetary carrier (1).
7. If removed, press bushing (23) inside end of output shaft (22) using installer tool (J37036) and a press.
8. Install output shaft (22), thrust washer (6), and retaining ring (7).
9. Install two bearing assemblies (8) into center of pinion gear (13). Install thrust washers (9 and 14) inside P3 planetary carrier (1), align thrust washer tangs with slots in planetary carrier, and retain them with petrolatum. Slide pinion gear and bearing assemblies into side of P3 planetary carrier between thrust washers. Repeat procedure for remaining three pinion gears.
10. Install four pinion spindles (15) so that lower step is positioned for proper installation of indexing ring (5).
11. Install indexing ring (5) and retaining ring (4).
12. Measure pinion end play. Pinion end play must not exceed 0.037 in (0.94 mm). Check all four pinions.
13. Place P3 planetary carrier assembly (1) on work bench with output shaft up. Place rear cover (3) over output shaft.
14. If removed, install cone and roller bearing (12) into rear cover assembly (3) using drive sleeve tool J37034.
15. Install new locknut retainer (11).

**CAUTION**

Over-tightening bearing retainer locknut will damage cone and roller bearing assembly.

MODULE OVERHAUL - CONTINUED

Rear Cover and P3 Planetary Module Assembly - Continued

16. Install bearing retainer locknut (10). Tighten locknut to 55-65 lb-ft (74-88 Nm).

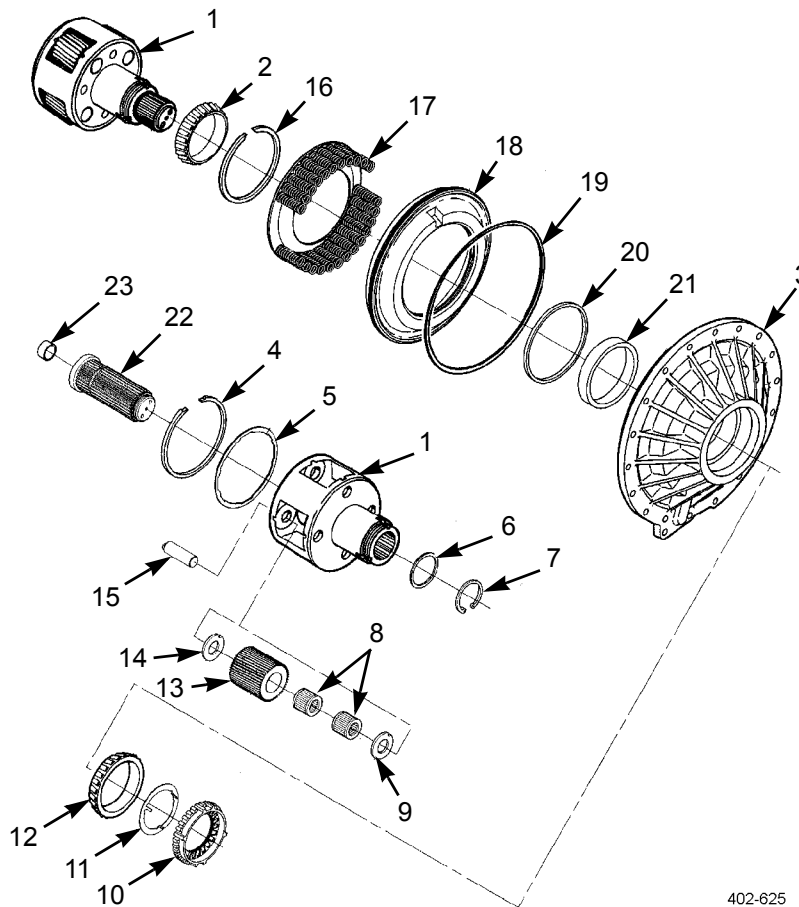

17. Position and support rear cover assembly (3) so that turning torque of P3 planetary carrier assembly can be checked after installation of bearing retainer locknut (10). Use tool (J37035-1) to check turning torque. Maximum turning torque is 27 lb-in (3 Nm).

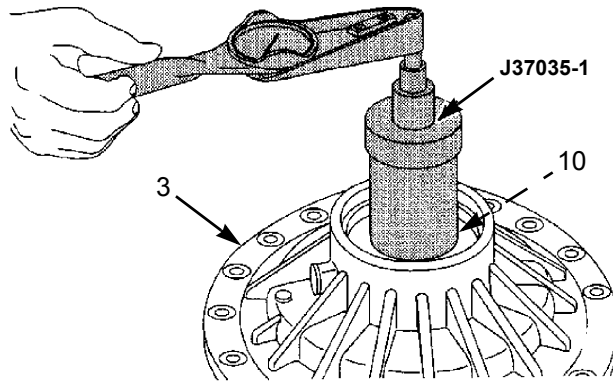

**MODULE OVERHAUL - CONTINUED****Control Valve Module Disassembly****NOTE**

The control valve module assembly springs and other parts can be mistakenly interchanged. Tag each part with its item name as it is removed and use valve tray set (J33163) to simplify correct valve reassembly.

1. Remove bolt (5) and two bolts (3) securing the suction filter housing (6).
2. Remove suction filter housing (6), filter (2), face seal (4), and gasket (1). Discard filter and gasket.
3. Remove four bolts (7) and wiring harness cover plate (8).
4. Tag and disconnect electrical connections.
5. Remove three bolts (10) and control harness assembly (9).
6. Remove three bolts (12) and rotating clutch solenoid body assembly (11).
7. Remove eight bolts (16) and stationary clutch solenoid assembly (15).
8. Remove two bolts (40) and main valve body assembly (87) (see page 0252 00-45 for illustration).

**NOTE**

Rotating clutch solenoid body disassembly procedures are steps 9 through 14.

9. Remove two bolts (14) and then remove C3 pressure switch (13) from rotating clutch solenoid body assembly (11).
10. Check resistance of C3 pressure switch. Maximum allowable resistance is 2 ohms when contacts are closed and must be 20,000 ohms minimum when contacts are open. Check pressure at which switch opens and closes. Both events must occur between 23-37 psi (104-255 kPa). Test block tool (J33884-25) is used to help make these checks.

**NOTE**

Solenoid retention pins (24) must be removed from bottom of solenoid body. Note grooved end of pin for positive retention.

11. Remove face seal (17), two solenoids (22), and one solenoid (23) by removing retention pins (24).
12. Remove three smaller O-rings (20) and three larger O-rings (21). Remove three solenoid regulator valves (19) and three springs (18).
13. Check resistance of each solenoid. Resistance must be 2-5 ohms.
14. Remove valve retention pin (25), stop (28), valve (26), and spring (27) from rotating clutch solenoid body (11).

**NOTE**

Stationary clutch solenoid body disassembly procedures are steps 15 through 20.

15. Remove two seals (38) from stationary clutch solenoid body (15).

**NOTE**

Solenoid retention pin (29) must be removed from bottom of solenoid body. Note grooved end of pin for positive retention.

16. Remove three solenoid retention pins (29) from bottom of solenoid body (15).
17. Remove three solenoids (33), six O-rings (34), three solenoid regulator valves (31), and three springs (30).
18. Check resistances of solenoids. Resistance must be 2-5 ohms.
19. Remove valve retention pin (32), stop (35), spring (36), and valve (37).



MODULE OVERHAUL - CONTINUED

Control Valve Module Disassembly - Continued

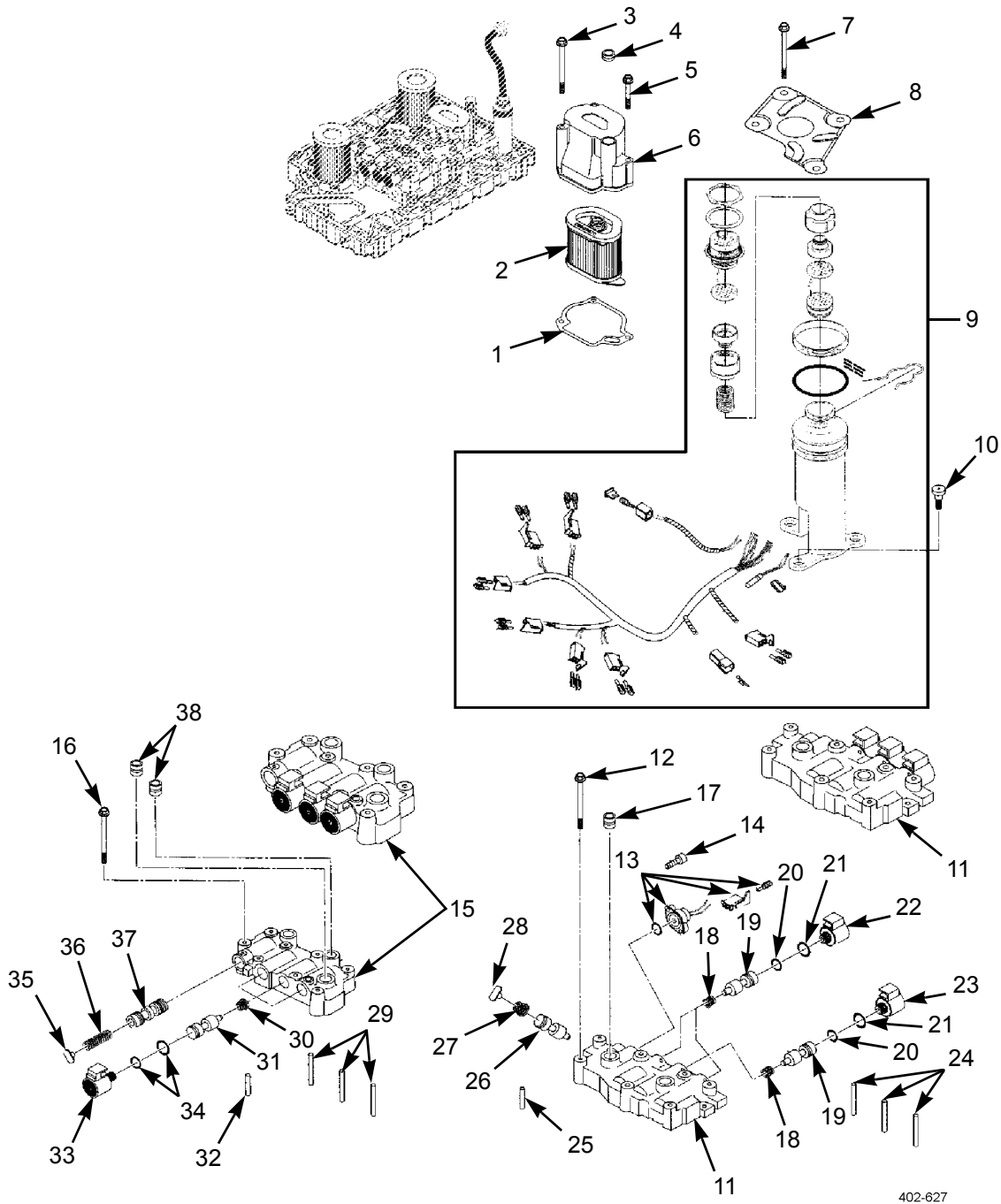

**MODULE OVERHAUL - CONTINUED****Control Valve Module Disassembly - Continued**

20. Remove solenoid separator plate (39).

**NOTE**

Main valve body disassembly procedures are steps 21 through 34.

21. If damaged, remove retention pin (74) from main valve body (87).

**NOTE**

Solenoid retention pins must be removed from bottom of valve body. Note grooved end of pin for positive retention.

22. Remove solenoid retention pin (49) from bottom of valve body (87).  
 23. Remove solenoid (71), small O-ring (72), and large O-ring (73).  
 24. Check resistances of solenoids. Resistance must be 2-5 ohms.  
 25. Remove valve retention pin (43). Remove stop (52), spring (51), and converter flow valve (50).  
 26. Remove valve retention pin (46), stop (53), spring (54), and lubrication regulator valve (55).

**WARNING**

Spring (57) is highly compressed. Be extremely careful during disassembly. Personal injury can occur if spring force is not controlled.

27. Install spring compressor tool (J35924). Compress spring (57), then remove valve retention pin (47). Carefully release spring force by rotating tool handle counterclockwise. Remove spring compressor tool.

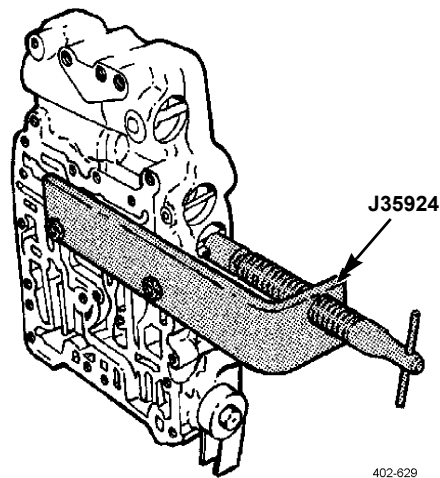

28. Remove stop (56), spring (57), and main regulator valve (58).  
 29. Push against stop (59) to compress spring (60) and remove valve retention pin (48). Slowly release pressure against stop and remove stop, spring, and main control valve (61).  
 30. Remove valve retention pin (45), stop (77), spring (76), and C2 latch valve (75).  
 31. Remove retention pin (41), stop (84), spring (85), and exhaust back pressure valve (86).

**MODULE OVERHAUL - CONTINUED**

**Control Valve Module Disassembly - Continued**

- 32. Remove retention pin (44), stop (78), spring (79), and C1 latching valve (80).
- 33. Remove retention pin (42), stop (81), spring (82), and converter regulator valve (83).

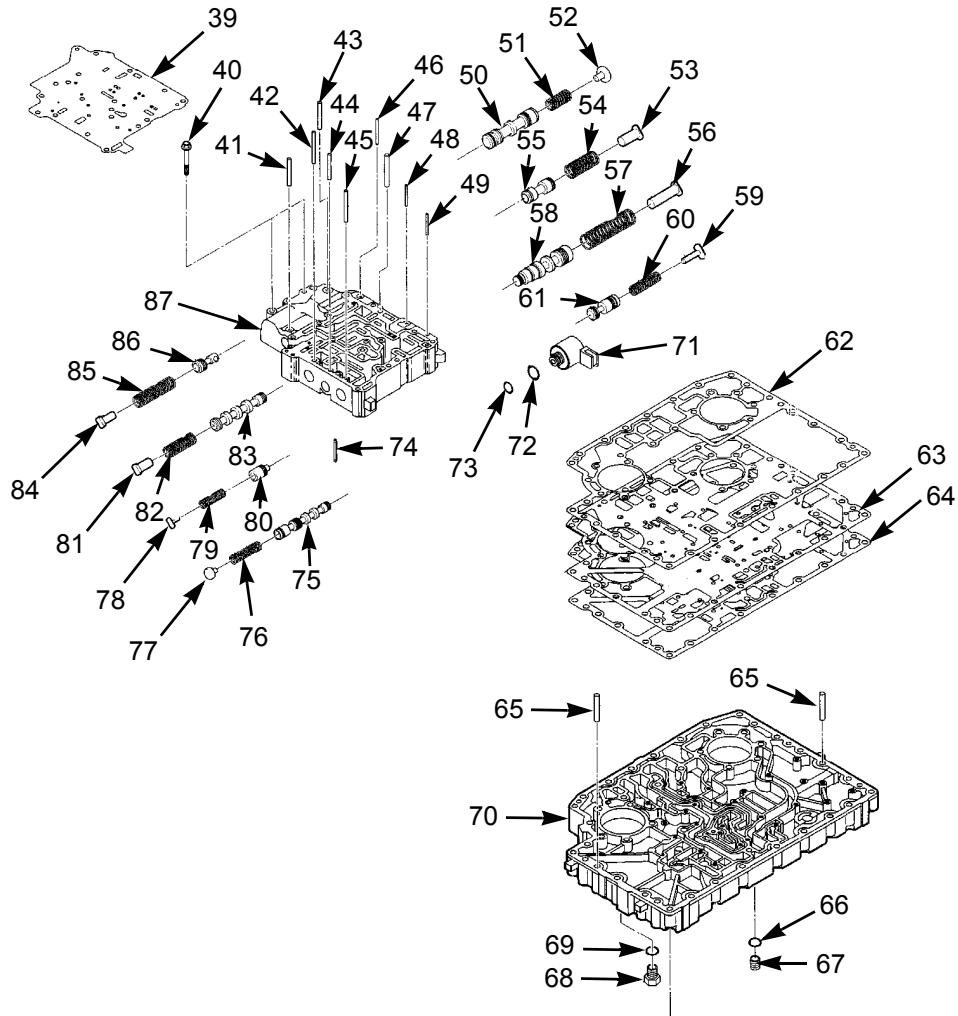

402-628

- 34. Remove gaskets (62 and 64) and separator plate (63) from channel plate assembly (70). Discard gaskets.

**NOTE**

Channel plate disassembly procedures are steps 35 through 37.

- 35. If damaged, remove two pins (65) from channel plate assembly (70).
- 36. Remove drain plug (67) and O-ring (66) from channel plate assembly (70). Discard O-ring.
- 37. Remove eight pressure tap plugs (68) and O-rings (69) from channel plate assembly (70). Discard O-ring.

**MODULE OVERHAUL - CONTINUED****Control Valve Module Assembly****NOTE**

Channel plate assembly procedures are steps 1 through 4.

1. Install eight pressure tap plugs (68) and new O-rings (69). Tighten plugs to 7-10 lb-ft (10-13 Nm).
2. Install drain plug (67) and new O-ring (66). Tighten drain plug to 18-24 lb-ft (25-32 Nm).
3. If removed, install two pins (65) in channel plate assembly (70).
4. Install new gaskets (62 and 64) with separator plate (63) on channel plate assembly (70).

**NOTE**

Main valve body assembly procedures are steps 5 through 18.

5. Install converter regulator valve (83), spring (82), and stop (81).
6. Install valve retention pin (42) by pushing against stop (81) to compress spring (82).
7. Install C1 latching valve (80), spring (79), and stop (78). Install retention pin (44).
8. Install exhaust back pressure valve (86), spring (85), and stop (84). Install retention pin (41).
9. Install C2 latch valve (75), spring (76), and stop (77). Install retention pin (45).

**WARNING**

Spring (57) is highly compressed. Be extremely careful during assembly. Personal injury can occur if spring force is not controlled.

10. Install main control valve (61), spring (60), and stop (59). Install retention pin (48).
11. Install main regulator valve (58), spring (57), and stop (56).
12. Using spring compressor tool (J35924), compress spring (57) and install valve retention pin (47).
13. Carefully remove compressor tool.
14. Install lubrication regulator valve (55), spring (54), and stop (53). Install retention pin (46).
15. Install converter flow valve (50), spring (51), and stop (52). Install retention pin (43).
16. Install new small O-ring (72) and new large O-ring (73) on solenoid (71). Install solenoid.
17. Install solenoid retention pin (49), smooth side first, from bottom of main valve body assembly (87).
18. If removed, install retention pin (74) in main valve body assembly (87).

MODULE OVERHAUL - CONTINUED

Control Valve Module Assembly - Continued

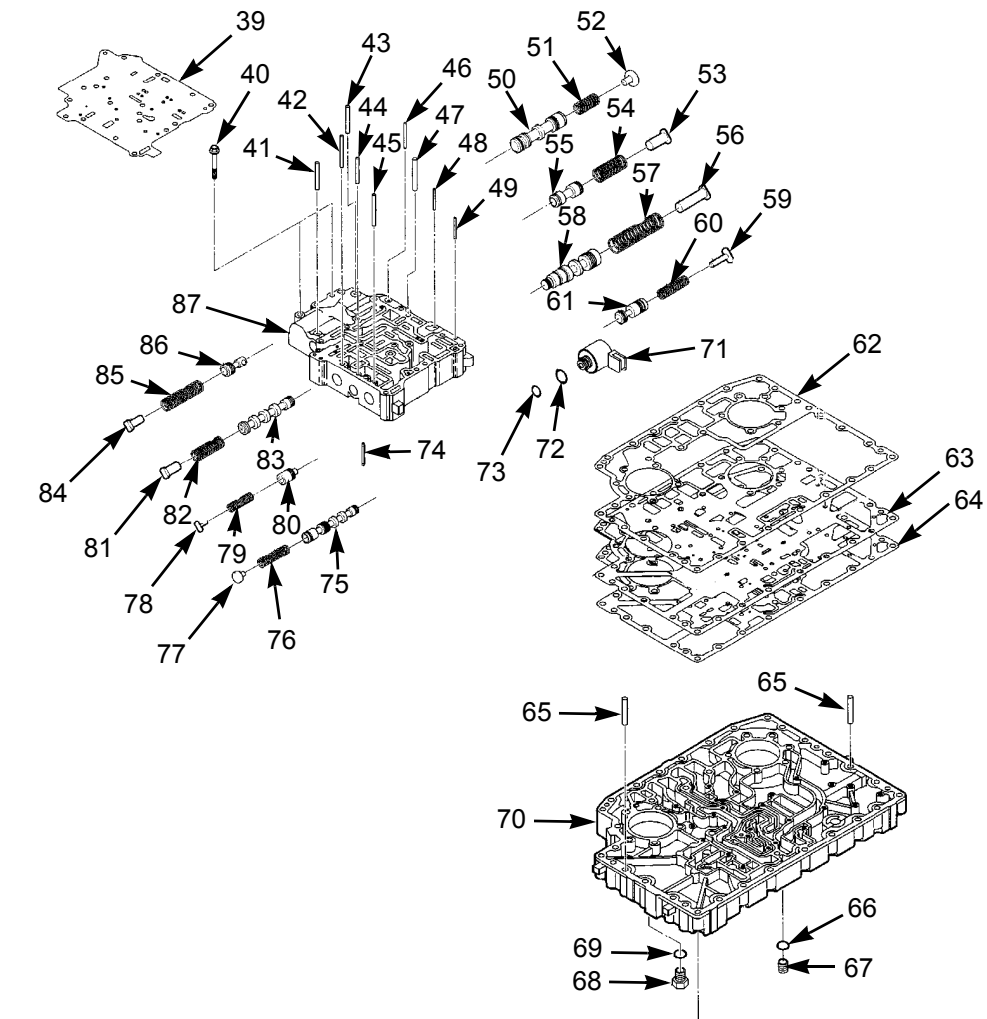

402-628

**MODULE OVERHAUL - CONTINUED****Control Valve Module Assembly - Continued****NOTE**

Stationary clutch solenoid body assembly procedures are steps 19 through 22.

19. Install valve (37), spring (36), and stop (35) in stationary clutch solenoid body (15). Install retention pin (32).
20. Install three springs (30), solenoid regulator valves (31), six new O-rings (34), and three solenoids (33).
21. As valve bores are filled, install three solenoid retention pins (29), smooth end first from bottom of solenoid body.
22. Install two new seals (38) in stationary clutch solenoid body (15).

**NOTE**

Rotating clutch solenoid body assembly procedures are steps 23 through 27.

23. Install spring (27), valve (26), and stop (28) in rotating clutch solenoid body (11) with retention pin (25).
24. Install three springs (18), three solenoid regulator valves (19), new smaller O-rings (20), and new larger O-rings (21).
25. Install face seal (17), two solenoids (22), and solenoid (23).
26. Install solenoid retention pins (24), smooth end first, from bottom of rotating clutch solenoid body (11).
27. Install pressure switch assembly (18) and two bolts (14). Tighten bolts to 44-71 lb-in (5-8 Nm).

**NOTE**

Control valve module assembly procedures are steps 28 through 37.

28. Install main valve body assembly (87) and two bolts (40) (see page 0248 00-45 for illustration). Tighten bolts only finger tight.
29. Install control harness assembly (9) with three bolts (10). Tighten bolts to 18-26 lb-in (2-3 Nm).
30. Install new gasket (1), new face seal (4) and new filter (2) in suction filter housing (6).
31. Install suction filter housing (6) with bolts (5) and two bolts (3). Tighten bolts only finger tight.
32. Install solenoid separator plate (39).
33. Install stationary clutch solenoid body assembly (15) with eight bolts (16). Tighten bolts only finger tight.
34. Install rotating clutch solenoid body (11) with three bolts (12). Tighten bolts only finger tight.
35. Install wiring harness cover plate (8) with four bolts (7). Tighten bolts only finger tight.
36. Connect all electrical connectors. Remove tags.
37. Evenly tighten cover plate bolts (7), suction filter bolts (3 and 5), valve body bolts (10, 12, and 16). Tighten all bolts to 7-10 lb-ft (10-13 Nm).

MODULE OVERHAUL - CONTINUED

Control Valve Module Assembly - Continued

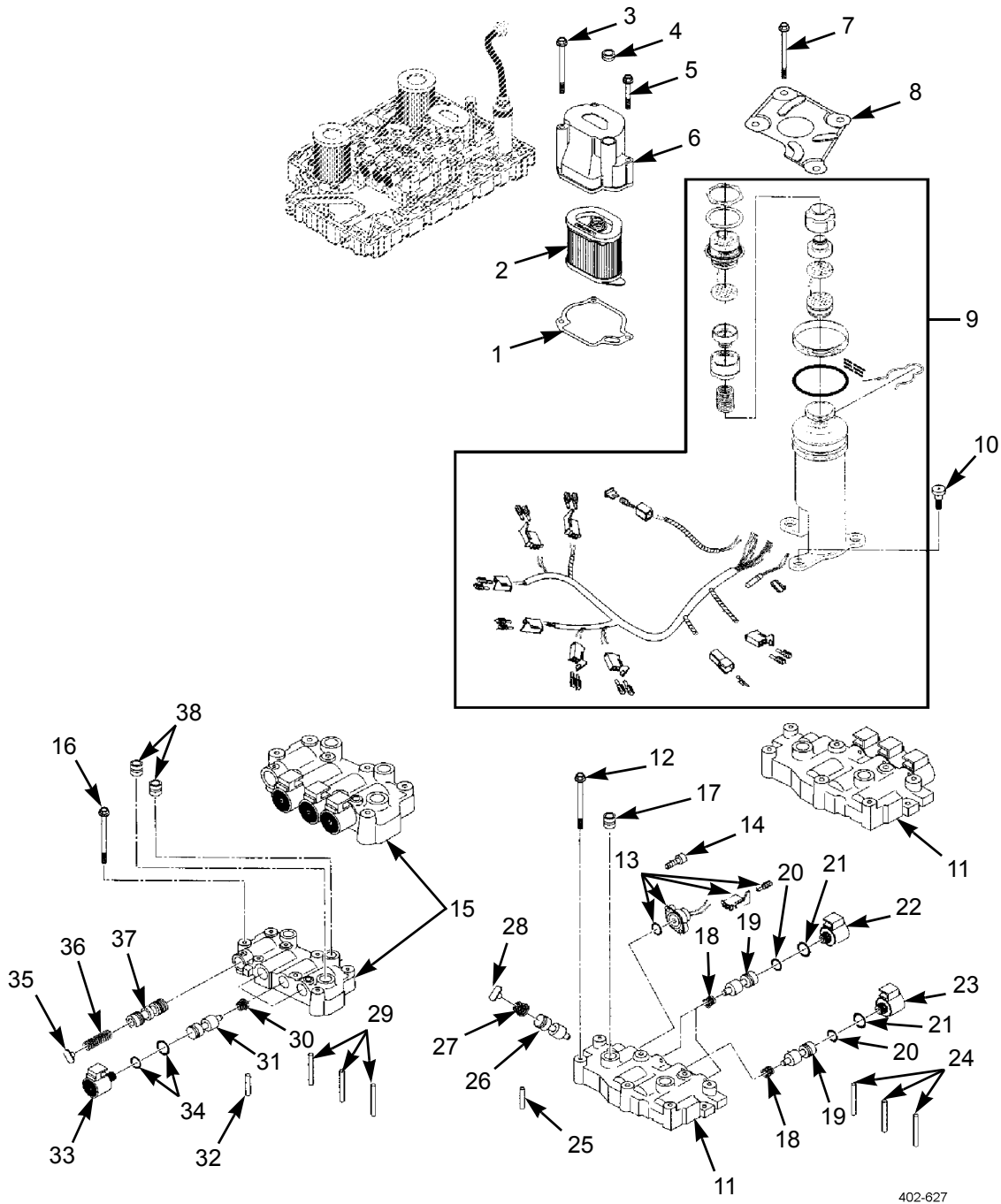

402-627

**ASSEMBLY**

Use extreme caution when handling heavy parts. Provide adequate support and use assistance during procedure. Ensure that any lifting device used is in good condition and of suitable load capacity. Keep clear of heavy parts supported only by lifting device. Failure to follow this warning may result in death or injury to personnel.

**NOTE**

- Ensure all transmission components are cleaned and well lubricated before reassembling transmission assembly.
- Before beginning assembly, attach bracket (J41445) and holding fixture (J35926) to main transmission housing. Use a suitable hoist to mount fixture and housing on a repair stand.
- Ensure main housing is horizontal when installing C3/C4 clutch Module.

**Installation of C3/C4 Clutch Assembly**

1. Install C3/C4 clutch assembly (51) through input end of main housing (24), aligning bolt holes in clutch assembly with holes in main housing.
2. Install two bolts (52), 180 degrees from each other, to hold clutch in place.
3. Rotate transmission housing on stand and install remaining 12 bolts (52). Tighten bolts to 38-45 lb-ft (51-61 Nm).

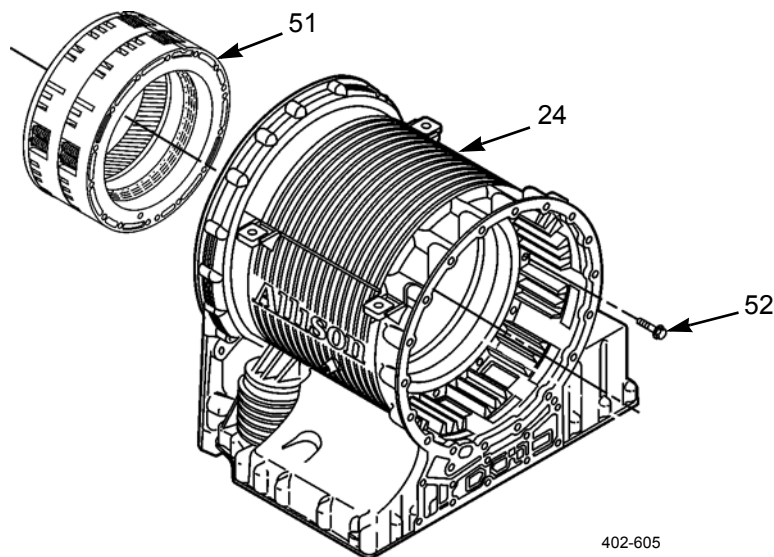
**Installation of Rotating Clutch Module and Front Support and Charging Pump Module**

1. Install an M16 eye bolt into turbine shaft (49). Using a suitable hoist, install rotating clutch module (50) into main housing (24). Remove eye bolt.
2. Lower front support and charging pump module (47) over top of turbine shaft (49).
3. Align bolt holes in front support and charging pump module (47) with threaded holes in main housing (24).
4. Install seven bolts (46) and seven bolts (48) in front support and charging pump module (47). Tighten bolts to 38-45 lb-ft (51-61 Nm).



**ASSEMBLY - CONTINUED**

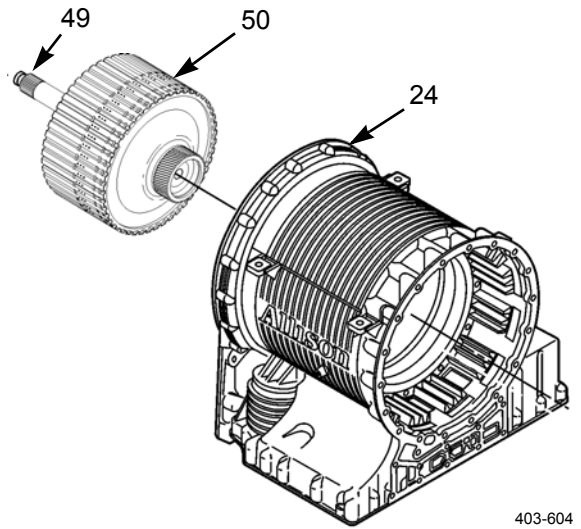
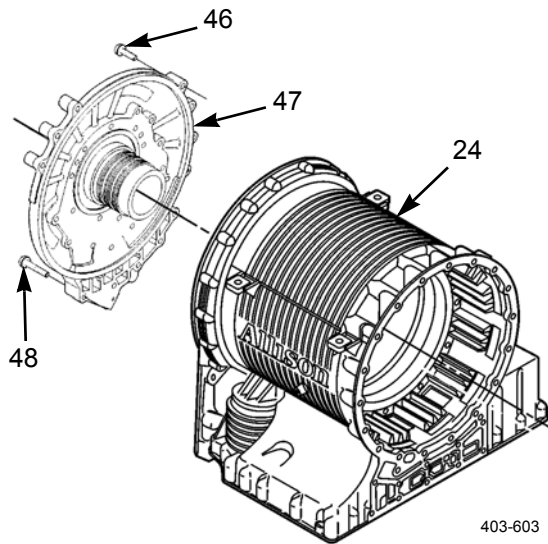

**Installation of P1/P2 Planetary Modules**

1. Install P1 planetary module (45), consisting of P1 carrier and P2 ring gear.
2. Mesh P1 pinion gears with P1 ring gear inside C3/C4 clutch assembly.
3. Install P2 planetary module (41), consisting of P2 carrier and P3 ring gear.
4. Mesh P2 pinion gears with P2 ring gear during installation.

**Installation of C5 Clutch Pack**

1. Install C5 clutch pack (42) in main housing (24). Clutch pack consists of nine steel reaction plates (44) and eight friction plates (43), stacked alternately, starting with a steel reaction plate.
2. Stack all plates so that plate cone faces same direction. Steel plates mesh with main housing (24) and reaction plates mesh with P3 ring gear.

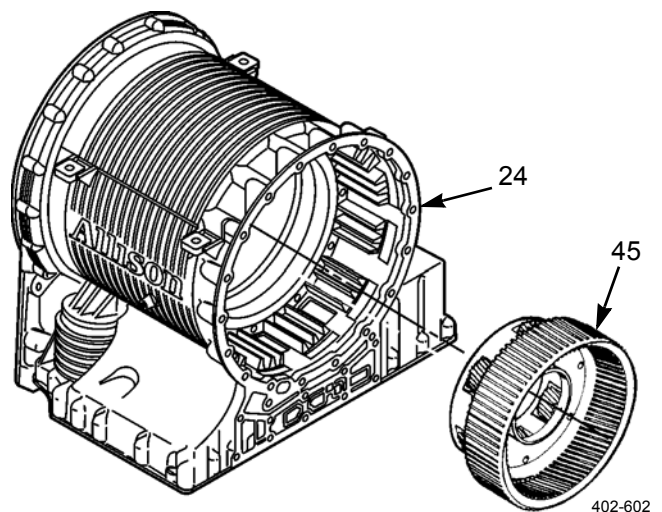
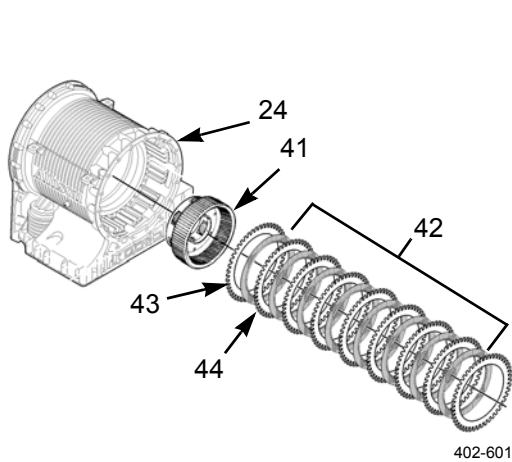

**ASSEMBLY - CONTINUED****Installation of Main Shaft Module and Selective Shim Measurement**

1. Install main shaft module assembly (38) in main housing (24), without selective shim (40) and thrust bearing (39).

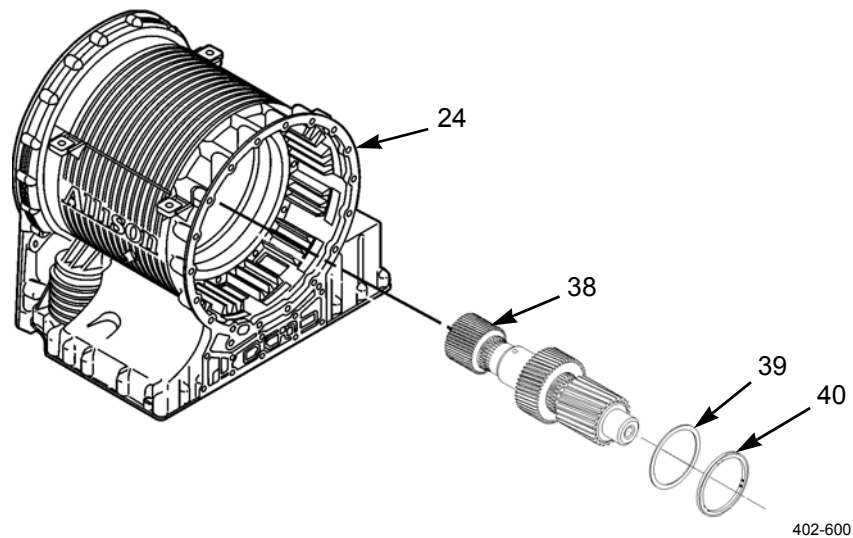

2. Place a straightedge across rear cover mounting surface.
3. Measure dimension "A", from top of straightedge to selective shim thrust surface on main shaft bearing spacer.
4. Measure dimension "B", thickness of straightedge. Subtract "B" from "A"; remainder is dimension "C".

**ASSEMBLY - CONTINUED**

**Installation of Main Shaft Module and Selective Shim Measurement - Continued**

5. Place rear cover, output end down (facing work bench). Install an uncompressed gasket on rear cover mounting surface and place a straightedge across P3 planetary carrier.
6. Measure dimension "D", from top of straightedge to rear cover mounting gasket.
7. Measure dimension "E", thickness of straightedge. Subtract dimension "E" from dimension "D"; remainder is dimension "F".
8. Dimension "G" is remainder of "C" minus "F" and determines thickness of selective shim (39).

**CAUTION**

Ensure thrust bearing is assembled with locating lip on either inner or outer thrust bearing race, not preventing race from contacting thrust surface of mating part. Failure to follow this caution leads to thrust bearing failure and incorrect shim selection to maintain proper part clearance.

9. Install proper thickness selective shim (40) and thrust bearing (39).

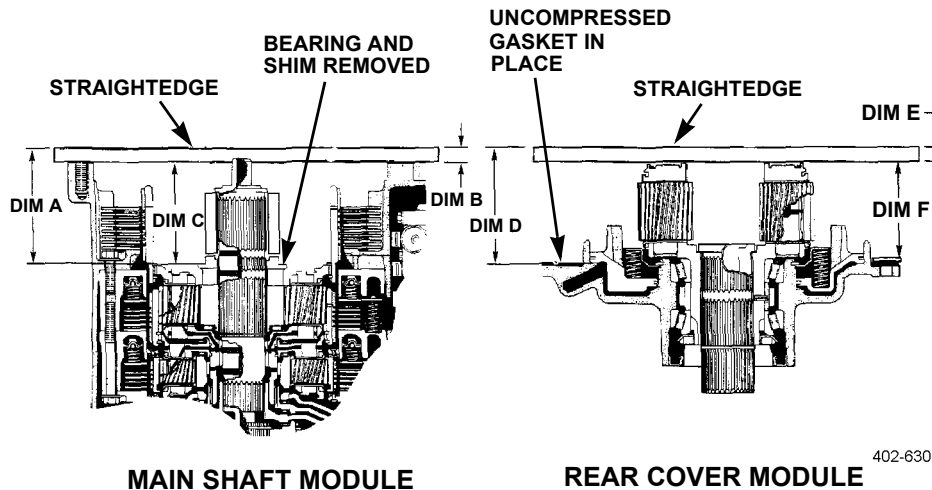

**PROCEDURE: FORMULA (C) - (F) = G**

DIM G	Use P/N	Shim ID
4.574-4.843 mm (0.180-0.190 in)	29503218	1 Notch
4.844-5.113 mm (0.192-0.201 in)	29503219	2 Notches
5.114-5.383 mm (0.202-0.212 in)	29503220	3 Notches
5.384-5.653 mm (0.213-0.223 in)	29503221	4 Notches
5.654-5.923 mm (0.224-0.233 in)	29503222	5 Notches
5.924-6.193 mm (0.234-0.244 in)	29503223	6 Notches
6.194-6.463 mm (0.245-0.254 in)	29503224	7 Notches

**ASSEMBLY - CONTINUED****Installation of Rear Cover Module**

1. Install new rear cover gasket (37) on main housing (24).
2. Place rear cover module (36) on main housing (24) using suitable hoist and sling as a lifting fixture.
3. Install 19 bolts (35). Evenly tighten bolts to 66-81 lb-ft (90-110 Nm).
4. Retighten retainer locknut using tool (J37035-1) to 55-65 lb-ft (74-88 Nm).

**NOTE**

Do not reuse locknut retainer locking tang once it has been bent. If all tangs have been used (bent), replace locknut retainer.

5. Locate one new locking tang on retainer and bend it up to hold retainer locknut.

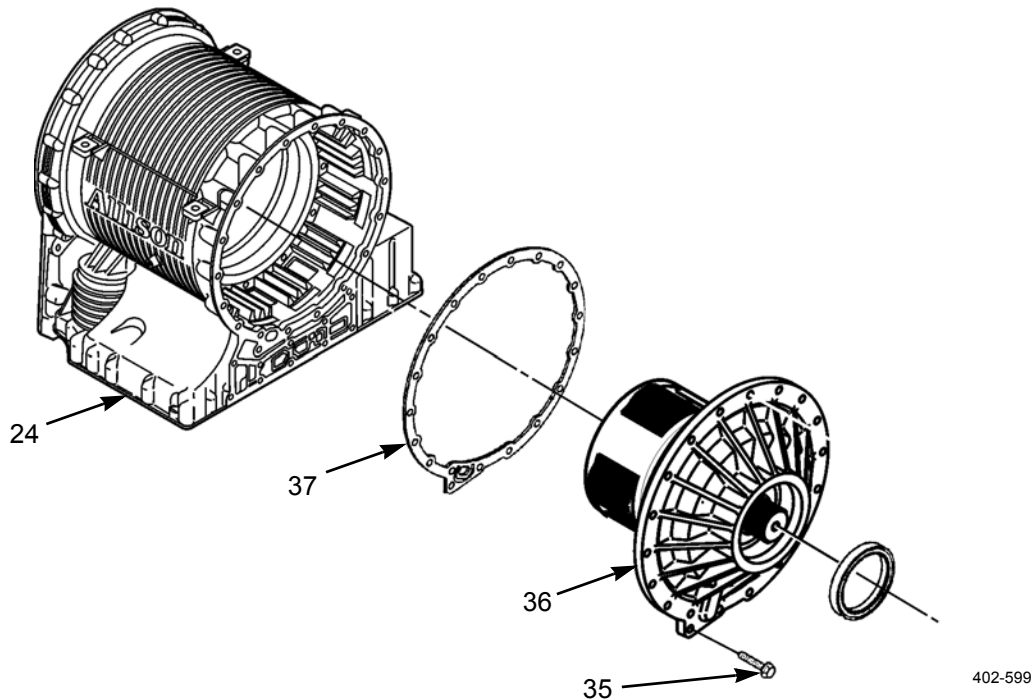

**ASSEMBLY - CONTINUED****Installation of Torque Converter Housing Module**

1. Position transmission with input end up. Install a new converter housing gasket (25) on main housing (24).
2. Lower torque converter housing (22) onto main housing (24) while rotating PTO drive gear to align gear teeth with charging pump.
3. Install seven bolts (23) into inside of torque converter housing (22). Use of mechanical fingers or similar tool may be required to insert and start bolts.
4. Install remaining 18 bolts (23). Tighten all bolts to 55-65 lb-ft (74-88 Nm).

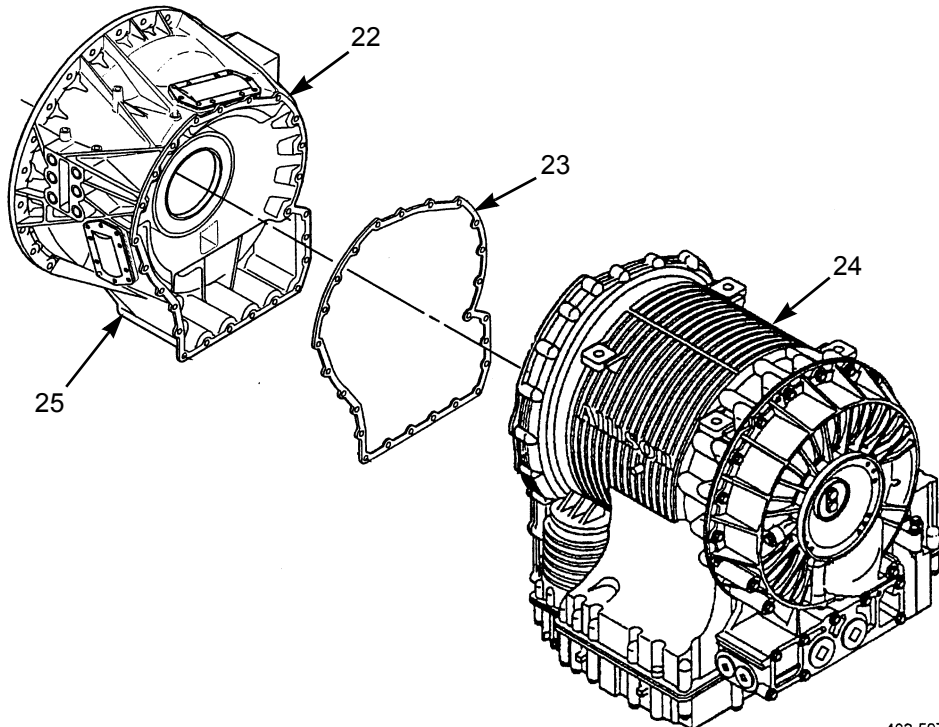

402-597

**ASSEMBLY - CONTINUED****Installation of Torque Converter Module and Selective Shim Measurement****NOTE**

- Torque converter is installed over turbine shaft which rotates inside stator shaft or ground sleeve. Splines on ground sleeve engage converter stator. Splines on turbine shaft engage converter turbine. End of turbine shaft is threaded and machined to accept converter retaining bolt and lockup seal ring.
  - Splines of ground sleeve and turbine shaft must engage with their respective splines in torque converter module. Tangs on converter-pump hub must engage charging pump's drive gear or PTO oil pump drive gear hub.
1. Using a suitable hoist and sling, install torque converter module (19) into torque converter housing (22).
  2. Ensure that torque converter module (19) is properly seated. Rotate PTO gear to engage pump hub with charging pump.
  3. Install converter end play gage tool (J38548) and tighten attaching bolts to 20-25 lb-ft (27-34 Nm). Install two bolts (16) into flexplate adapter (18). Use two bars at an angle to prevent turbine shaft rotation.
  4. Measure from top of end play gage tool (J38548) to face of turbine shaft and record it as dimension "B". Subtract dimension "B" from dimension "A" to determine dimension "C" (Note dimension "A" is height of tool J38548, 3.937 inch (100.00 mm)).
  5. Use dimension "C" and Table 1, Torque Converter Selective Shims, located at the end of this work package, to determine proper selective shim part number.
  6. Remove torque converter end play tool (J37548).
  7. Install selective shim (19) with step side down, toward turbine shaft. Install converter center bolt (14) with converter tightening tool (J38564) and retaining ring (21).

**NOTE**

Turbine and turbine shaft may rotate while attempting to tighten retaining bolt. Prevent turbine shaft from turning in same manner as in step number 3.

8. Tighten converter center bolt (14) to 74-88 lb-ft (100-120 Nm). Remove retaining ring (21) and tool (J38564) and replace with converter plug (20), O-ring (13), and retaining ring.
9. Install torque converter shipping bracket. Tighten shipping bracket mounting bolts to 38-45 lb-ft (51-61 Nm).

ASSEMBLY - CONTINUED

Installation of Torque Converter Module and Selective Shim Measurement

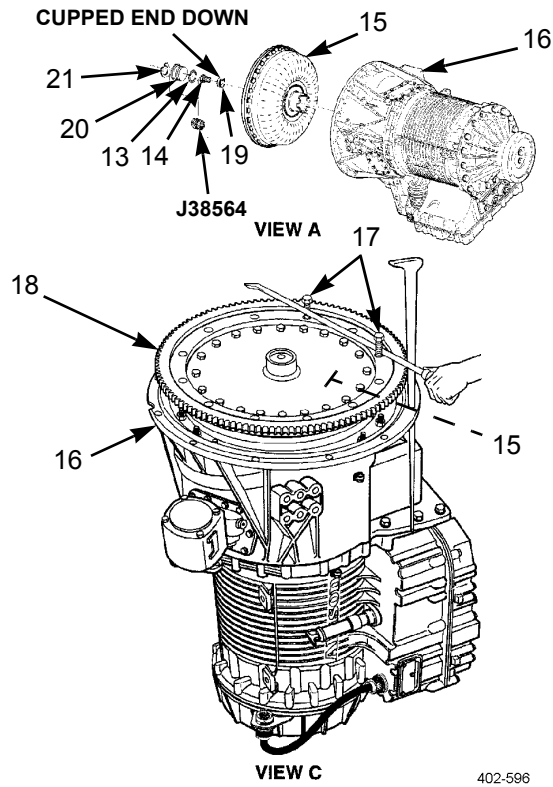

402-596

**ASSEMBLY - CONTINUED****Installation of Control Valve Module**

1. Position transmission in a vertical position, torque converter up.
2. Install two guide pins in two main housing bolt holes. Install new control module gasket (32) over guide pins.
3. Lubricate wiring harness feed-through hole with petrolatum.
4. With assistance, guide control module (33) onto main housing (24) and pass feed-through harness (28) through feed-through hole in the main housing.
5. Align control module (33) bolt holes with guide pins. Ensure feed-through harness standoff is aligned with hole in main housing (24).
6. Lower control module (33) over guide pins until it seats against main housing (24) and feed-through harness standoff seats against tapered hole in main housing.
7. Remove guide pins and install 43 bolts (34). Evenly tighten bolts to 38-45 lb-ft (51-61 Nm).
8. Install retaining nut (27) and lockwasher (28) to secure feed-through harness (29) to mounting bracket (26).
9. Install retaining nut (30) and lockwasher (31) to secure feed-through harness (29) to transmission housing (24).

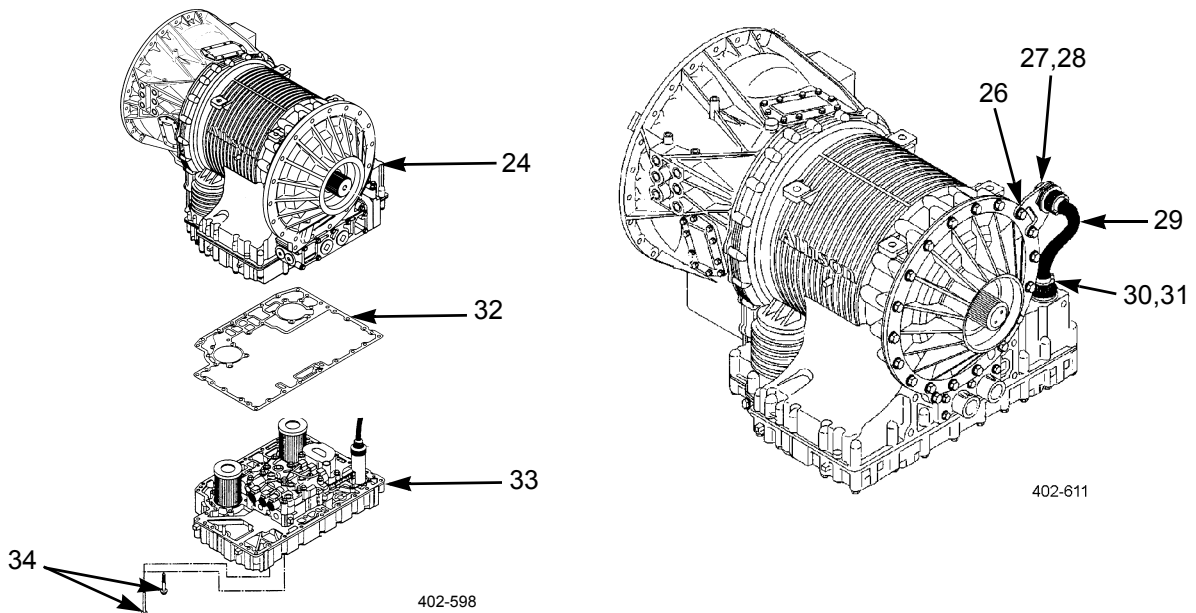



**ASSEMBLY - CONTINUED**

**Installation of Filters and Breather**

1. Install 12 bolts (6), two filter covers (5), new O-rings (4), new square cut seals (3), and new filters (2) in control module.
2. Install transmission breather vent (1) in torque converter housing.

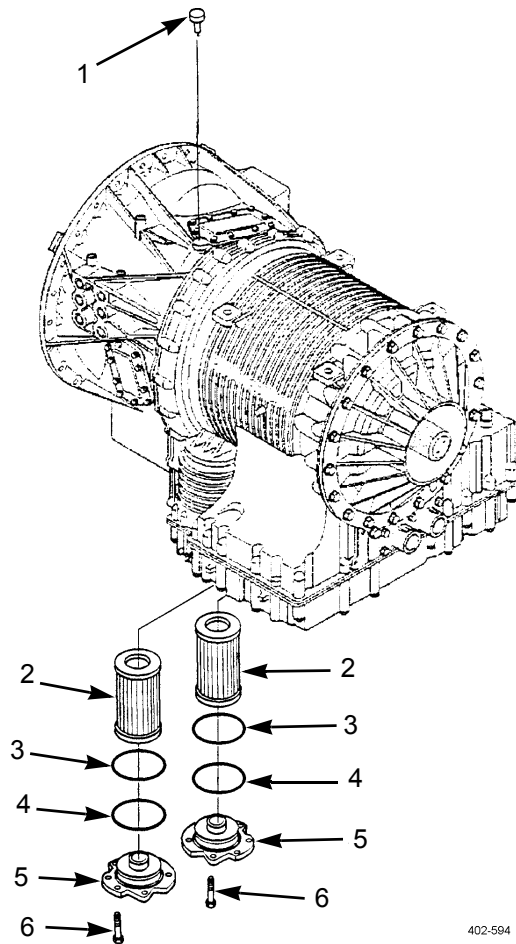

**ASSEMBLY - CONTINUED**

**Installation of Output Shaft and Oil Seal**

1. Install new oil seal (7) in rear cover.
2. Install output yoke (8) and new O-ring (9).
3. Insert bolt (12) through retainer plug (11). Install a new O-ring (10) on bolt so that O-ring seats against retainer plug.
4. Install retainer plug (11) into yoke (8). Tighten bolt (12) to 38-45 lb-ft (51-61 Nm).

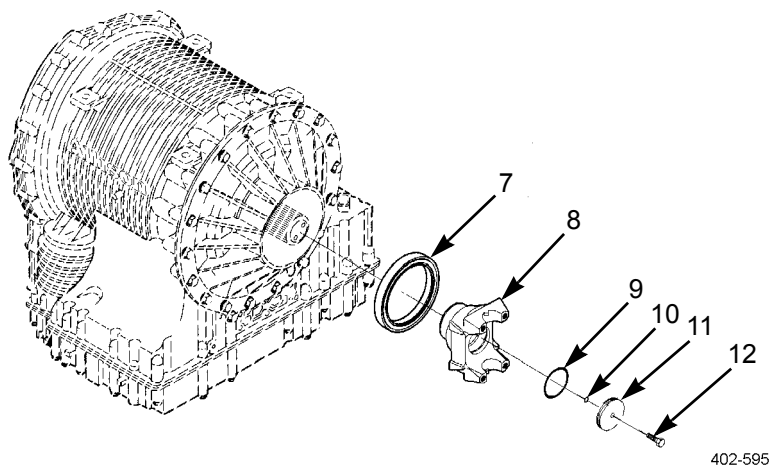

5. Install engine, turbine, and output speed sensors (WP 0112 00).

**TABULATED DATA**

**Table 1. Torque Converter Selective Shims.**

Dimension C	Use P/N	Shim Thickness (Ref.)	ID No.
0.4129-0.6598 mm (0.0163-0.0259 in)	29505688	4.000 mm (0.157 in)	0
0.6597-0.8378 mm (0.0260-0.0329 in)	29505681	4.203 mm (0.165 in)	1
0.8379-1.0158 mm (0.0330-0.0399 in)	29505682	4.381 mm (0.172 in)	2
1.0104-1.1938 mm (0.0400-0.0469 in)	29505683	4.559 mm (0.179 in)	3
1.1939-1.3708 mm (0.0470-0.0539 in)	29505684	4.736 mm (0.186 in)	4
1.3709-1.5488 mm (0.0540-0.0609 in)	29505685	4.914 mm (0.193 in)	5
1.5489-1.7268 mm (0.0610-0.0679 in)	29505686	5.092 mm (0.200 in)	6
1.7269-1.9048 mm (0.0680-0.0749 in)	29507793	5.230 mm (0.207 in)	7
1.9049-1.9733 mm (0.0750-0.0776 in)	29507794	5.448 mm (0.214 in)	8

**TABULATED DATA - CONTINUED**

**Table 2. Wear Limits Data.**

Description	Wear Limit	
	mm	inches
<b>TORQUE CONVERTER MODULE</b>		
Converter Cover Bushing, Maximum ID	66.91	2.634
Lockup Piston Assembly, Minimum Thickness	6.53	0.257
Damper Assembly Plate, Maximum Distortion	0.51	0.020
Damper Assembly Plate, Minimum Thickness	8.51	0.335
Turbine-to-damper, Maximum Spline Wear	0.38	0.015
Backplate, Maximum Distortion	0.15	0.006
Backplate, Minimum Wear Surface Thickness	11.79	0.464
Turbine Hub, Minimum OD	66.69	2.626
Stator Thrust Plate, Minimum Thickness	9.45	0.372
Converter Pump Hub, Minimum OD	88.99	3.504
<b>TORQUE CONVERTER HOUSING MODULE - PTO EQUIPPED</b>		
Bearing Retainer Bushing, Maximum ID	89.19	3.511
Oil Pump Drive Hub Seal, Minimum End Gap	1.18	0.046
Oil Pump Drive Hub Seal, Maximum End Gap	1.66	0.065
Oil Pump Drive Hub, Maximum Tank Wear	0.31	0.012
<b>FRONT SUPPORT AND CHARGING PUMP MODULE</b>		
Pump Housing Bushing, Maximum ID	89.19	3.511
Pump Housing Gear, Maximum Cavity Depth	19.04	0.750
Pump Housing Gear, Maximum Cavity Diameter	150.25	5.915
Driven Gear-to-pump Housing, Maximum Diametric Clearance	0.30	0.012
Gear Set, Maximum Gear Tooth Tip Clearance	0.15	0.006
Pump Gear Bushing, Maximum ID	66.93	2.635
Ground Sleeve, Minimum OD in Bushing Area	66.67	2.625
Spline OD, Maximum Total Runout	0.13	0.005
Front Support, Minimum OD	119.81	4.717
Front Support Seal, Minimum End Gap	1.00	0.040
Front Support Seal, Maximum End Gap	1.44	0.057

TABULATED DATA - CONTINUED

Table 2. Wear Limits Data - Continued.

Description	Wear Limit	
	mm	inches
<b>ROTATING CLUTCH MODULE</b>		
Turbine Shaft Bushing, Maximum ID	36.14	1.423
Turbine Seal, Minimum End Gap	0.65	0.026
Turbine Seal, Maximum End Gap	1.01	0.040
Drum Spline, Maximum Wear	0.38	0.015
Rotating Clutch Hub Bushing, Maximum ID	120.27	4.735
C1, C2 Clutch Backplate, Minimum Thickness	7.90	0.311
C1, C2 Clutch Backplate, Maximum Distortion	0.15	0.006
C1, C2 Friction Plate, Maximum Cone	0.25	0.010
C1, C2 Friction Plate, Minimum Thickness	2.92	0.115
C1, C2 Friction Plate, Minimum Oil Groove Depth	0.20	0.008
C1, C2 Reaction Steel Plate, Maximum Cone	0.25	0.010
C1, C2 Reaction Steel Plate, Minimum Thickness	2.41	0.095
C1, C2 Drive Hub, Maximum Spline Wear	0.38	0.015 <sup>c</sup>
C2 Backplate, Minimum Thickness	7.90	0.311
C2 Backplate, Maximum Distortion	0.15	0.006
<b>MAIN HOUSING MODULE</b>		
Backplate, Maximum Step Wear	0.13	0.005
Backplate, Maximum Distortion	0.15	0.006
P1 Ring Thrust Plate, Minimum Thickness at Wear Point	2.82	0.111
P1 Ring Gear Spline, Maximum Wear	0.38	0.015
C3, C4, C5 Friction Plate, Maximum Cone	0.25	0.010
C3, C4, C5 Friction Plate, Minimum Thickness	3.485	0.137
C3, C4, C5 Reaction (Steel) Plate, Maximum Cone	0.25	0.010
C3, C4, C5 Reaction (Steel) Plate, Minimum Thickness	2.41	0.095
C3, C4, Clutch Housings, Maximum Spline Wear	1.15	0.045
Main Housing, Maximum Spline Wear	1.15	0.045
<b>MAIN SHAFT MODULE - WIDE RATIO AND CLOSE RATIO</b>		
Main Shaft Bearing Journal, Minimum OD	52.98	2.086
Main Shaft Pilots (Both Ends), Minimum OD	35.92	1.414

## TABULATED DATA - CONTINUED

Table 2. Wear Limits Data - Continued.

Description	Wear Limit	
	mm	inches
<b>P1 PLANETARY MODULE</b>		
P1 Planetary Carrier Assembly, Maximum Pinion End Play	0.94	0.037
P1 Carrier Bushing, Maximum ID	89.32	3.517
P1 Pinion Thrust Washer, Minimum Thickness	1.40	0.055
P1 Pinion Trust Washer, Maximum Step Wear	0.12	0.005
P2 Ring Gear Spline, Maximum Wear	0.38	0.015
<b>P2 PLANETARY MODULE</b>		
P2 Planetary Carrier Assembly, Maximum Pinion End Play	0.94	0.037
P2 Carrier Bushing, Maximum ID	53.23	2.096
P2 Pinion Thrust Washer, Minimum Thickness	1.40	0.055
P2 Pinion Thrust Washer, Maximum Step Wear	0.12	0.005
P3 Ring Gear Spline, Maximum Wear	0.38	0.015
<b>REAR COVER AND P3 MODULE</b>		
P3 Planetary Carrier Assembly, Maximum End Play	0.94	0.037
Output Shaft Bushing, Maximum ID	36.14	1.423
Output Shaft, Maximum Spline Wear	0.38	0.015
P3 Pinion Thrust Washer, Minimum Thickness	1.40	0.055
P3 Pinion Thrust Washer, Maximum Step Wear	0.12	0.005
<b>OUTPUT FLANGE AND YOKE</b>		
Journal Seal, Maximum OD	85.0	3.346

Table 3. Wear Limits and Spring Data.

Spring	Part Number	Color Code	No. Of Coils	Wire Dia mm (in)	Spring Od mm (in)	Approx Free Length mm (in)	Length Under Load	
							mm (in)	n (lb)
Stator	29501300	No Code	N/A	N/A	N/A	17.8 (0.70)	5.7 (0.224)	0.9 (0.2)
Main Relief	29507709	No Code	10	3.25 (0.128)	17.96 (0.707)	52.4 (2.06)	40.7 (1.60)	474 (106.5)
C2 Return	29505719	No Code	11.5*	2.04* (0.080)	19.06* (0.750)	70.76* (2.786)	28.2 (1.110)	5185** (1165.6)
C1 Return	29509453	No Code	12*	2.10* (0.083)	16.0* (0.630)	57.53* (2.265)	34.8 (1.37)	4649** (1045.4)
C3 Return	29506206	No Code	13*	2.10* (0.083)	15.0* (0.590)	52.3* (2.06)	35.4 (1.39)	274.4** (61.69)
C3 Retainer	29507882	No Code	4*	2.36* (0.093)	12.62* (0.497)	11.2* (0.44)	9.3 (0.37)	16408** (3689)
C3 Retainer	29515628	No Code	4*	2.36* (0.093)	12.62* (0.497)	11.1* (0.44)	10.40 (0.41)	15403** (3463)
C4 Return	29506206	No Code	13*	2.10* (0.083)	15.0* (0.590)	52.3* (2.06)	35.4 (1.39)	274.4** (6169)
C4 Retainer	29507882	No Code	4*	2.36* (0.093)	12.62* (0.497)	11.2* (0.44)	9.3 (0.37)	16408** (3689)
C4 Retainer	29515628	No Code	4*	2.36* (0.093)	12.62* (0.497)	11.1* (0.44)	10.40 (0.41)	15403** (3463)
Retarder	6880775	Yellow/ Red Stripe	12	1.93 (0.076)	16.61 (0.654)	53.8 (2.12)	35.30 (1.390)	81.4 (18.30)
Retarder Control	29510495	Silver	7.5	1.40 (0.055)	15.1 (0.594)	3.08 (1.212)	18.0 (0.71)	33 (7.42)
Retarder Control	29512792	Lt. Green (on end)	7.5	1.40 (0.055)	15.09 (0.594)	33.69 (1.326)	18.0 (0.71)	40 (9.0)
Retarder Control	29510494	Orange	7	1.60 (0.063)	15.50 (0.610)	27.8 (1.09)	18.0 (0.71)	44 (9.9)

\* Individual springs

\*\* For complete spring assembly

Table 3. Wear Limits and Spring Data - Continued.

Spring	Part Number	Color Code	No Of Coils	Wire Dia mm (in)	Spring Od mm (in)	Approx. Free Length mm (in)	Length Under Load	
							mm (in)	n (lb)
Retarder Exh. Back	23049391	No Code	17	0.61 (0.024)	7.80 (0.307)	29.2 (1.14)	18.2 (0.72)	2 (0.5)
C5 Return	29503036	No Code	12*	2.10* (0.083)	17.00* (0.669)	57.3* (2.26)	37.6 (1.48)	3086** (693.8)
Solenoid Regulator	29502195	No Code	4	0.67 (0.026)	11.05 (0.440)	6.5 (0.26)	3.45 (0.14)	3 (0.7)
Accumulator Relay	29507455	Silver	12.8	1.28 (0.050)	11.68 (0.460)	43.6 (1.72)	20.0 (0.79)	47 (10.6)
Overdrive	23049332	Orange	12	0.76 (0.030)	7.75 (0.305)	26.6 (1.05)	12.5 (0.49)	12.0 (2.7)
Solenoid Regulator	29502195	No Code	4	0.67 (0.026)	11.05 (0.440)	6.5 (0.26)	3.45 (0.14)	3 (0.7)
Lockup	23049326	Yellow	10	1.37 (0.054)	14.1 (0.555)	42.1 (1.66)	17.0 (0.67)	49 (11.0)
Lube Regulator	23049327	Red	13	1.22 (0.048)	11.1 (0.437)	46.3 (1.82)	3.5 (0.93)	47 (10.6)
Main Regulator	29500963	Lt. Blue	15	2.87 (0.113)	22.00 (0.866)	98.5 (3.88)	54.6 (2.15)	305 (68.6)
Control Main	23049325	Orange	10	1.83 (0.072)	14.8 (0.583)	44.6 (1.76)	24.0 (0.95)	131 (29.5)
C2 Latch	29501071	Lt. Green	11	1.32 (0.052)	11.43 (0.450)	41.3 (1.63)	19.0 (0.75)	71.0 (16.0)
Exh. Back	23049391	No Code	17	0.61 (0.024)	7.80 (0.307)	29.2 (1.14)	18.2 (0.72)	2 (0.5)
C1 Latch	6885065	Blue	12	1.37 (0.054)	16.26 (0.640)	46.2 (1.82)	29.2 (1.15)	18 (4.0)
Converter Regulator	29507456	Pink	10.2	1.53 (0.060)	11.00 (0.433)	30.3 (1.19)	22.8 (0.90)	54 (12.1)

\* Individual springs

\*\* For complete spring assembly

END OF WORK PACKAGE

0248 00-63/(0248 00-64 Blank)

Change 1

TM 9-2320-303-24-2





**TRANSMISSION OVERHAUL (M915A4R2)****0248 01****THIS WORK PACKAGE COVERS**

Disassembly, Module Overhaul, Assembly, Tabulated Data

**INITIAL SETUP****Maintenance Level**

General Support

**Tools and Special Tools**

Tool kit, general mechanic's (Item 102, WP 0313 00)  
 Tool kit, transmission (Item 104, WP 0313 00)  
 Adapter, torque wrench (Item 2, WP 0313 00)  
 Bracket, mounting (Item 6, WP 0313 00)  
 Bracket, vehicular components (Item 7, WP 0313 00)  
 Bushing, sleeve (Item 8, WP 0313 00)  
 Caliper, micrometer (Item 9, WP 0313 00)  
 Compressor, spring (Item 12, WP 0313 00)  
 Compressor, spring (Item 13, WP 0313 00)  
 Compressor, spring (Item 14, WP 0313 00)  
 Gage, depth, micrometer (Item 23, WP 0313 00)  
 Gage, profile (Item 25, WP 0313 00)  
 Inserter and remover (Item 38, WP 0313 00)  
 Inserter and remover (Item 40, WP 0313 00)  
 Inserter, bearing and bushing (Item 41, WP 0313 00)  
 Inserter, bearing and bushing (Item 42, WP 0313 00)  
 Inserter, bearing and bushing (Item 43, WP 0313 00)  
 Inserter, bearing and bushing (Item 44, WP 0313 00)  
 Inserter, bearing and bushing (Item 45, WP 0313 00)  
 Inserter, bearing and bushing (Item 46, WP 0313 00)  
 Inserter, seal (Item 47, WP 0313 00)  
 Inserter, seal (Item 48, WP 0313 00)

**Tools and Special Tools - Continued**

Inserter, seal (Item 49, WP 0313 00)  
 Inserter, seal (Item 50, WP 0313 00)  
 Installer, seal (Item 51, WP 0313 00)  
 Installer, slinger (Item 51.1, WP 0313 00)  
 Lifting bracket, flywheel (Item 57, WP 0313 00)  
 Parts kit, valves (Item 63, WP 0313 00)  
 Press, arbor (Item 71, WP 0313 00)  
 Puller kit, universal (Item 74, WP 0313 00)  
 Remover, seal (Item 75.1, WP 0313 00)  
 Remover, wheel bearing cup (Item 76, WP 0313 00)  
 Ring, retaining (Item 77, WP 0313 00)  
 Ring, retaining (Item 78, WP 0313 00)  
 Sling, nylon (Item 86, WP 0313 00)  
 Socket, socket wrench (Item 88, WP 0313 00)  
 Socket, socket wrench (Item 89, WP 0313 00)  
 Spanner (Item 91, WP 0313 00)  
 Switch, pressure (Item 95, WP 0313 00)  
 Wrench, torque, 0-300 lb-in. (Item 109, WP 0313 00)  
 Wrench, torque, 15-75 lb-ft (Item 110, WP 0313 00)

**Materials/Parts**

Oil, lubricating (Item 27, WP 0312 00)  
 Petrolatum, technical (Item 37, WP 0312 00)  
 Tags, marker (Item 42, WP 0312 00)

**Personnel Required**

Two

**Equipment Condition**

Transmission installed on maintenance stand  
 Engine, turbine, and output speed sensors removed (WP 0112 00)

**DISASSEMBLY**



**WARNING**



Use extreme caution when handling heavy parts. Provide adequate support and use assistance during procedure. Ensure that any lifting device used is in good condition and of suitable load capacity. Keep clear of heavy parts supported only by lifting device. Failure to follow this warning may result in death or injury to personnel.

**NOTE**

Confirm transmission has been drained prior to disassembly.

**Removal of Filters and Breather**

1. Remove 12 bolts (6), two filter covers (5), O-rings (4), square cut seals (3), and filters (2). Discard O-rings, seals, and filters.
2. Remove transmission breather vent (1) from torque converter housing.

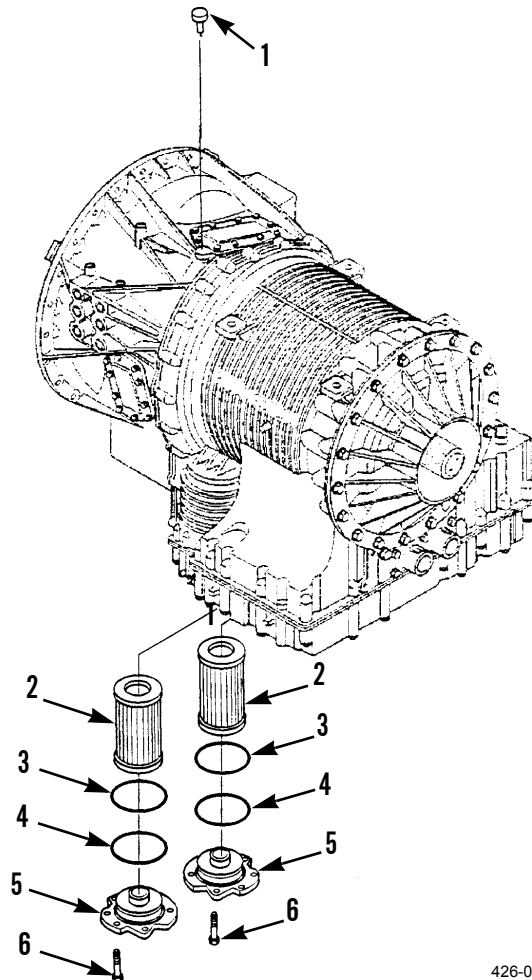

426-067

**DISASSEMBLY - CONTINUED****Removal of Output Shaft and Oil Seal**

1. Remove bolt (13), retainer plug (12), and O-rings (10 and 11) from output shaft yoke (9). Discard O-rings.
2. Remove slinger (8).
3. Remove oil seal (7) using puller (J24171-A). Discard oil seal.

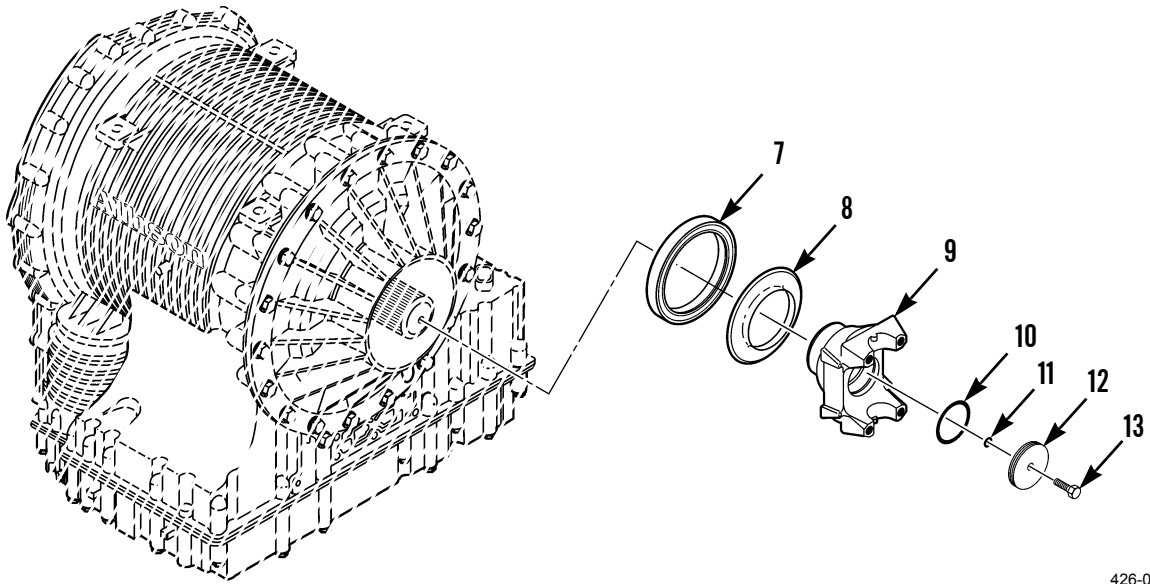

426-068

**DISASSEMBLY - CONTINUED**

**Removal of Torque Converter Module**

1. Remove any brackets installed to prevent torque converter movement.
2. Keep torque converter cover from turning by using bar, two bolts, and screwdriver (see View C).
3. Remove threaded plug (14) and O-ring (15). Discard O-ring.
4. Attempting to loosen bolt (16) may cause turbine and turbine shaft to rotate. Hold the turbine and turbine shaft stationary by using one of two methods that follow:
  - a. If control module is removed, insert a screwdriver into vanes on rotating clutch module (see View B).
  - b. If control module is in place, apply lockup clutch by applying restricted air pressure through lockup pressure tap located on main housing (see View D). Insert bar into a torque converter housing bolt hole. Insert two bolts into flexplate adapter bolt holes, then place a screwdriver at an angle to prevent converter rotation (see View C).
5. Install two bolts (20) into flexplate adapter (21). Use two bars at an angle to prevent rotation of torque converter (18).
6. Using converter bolt tool J38564, remove bolt (16).
7. Remove shim (17) located under bolt (16).
8. Attach a suitable lifting sling to flexplate adapter (21) by positioning adapter connections equal distances apart from each other.
9. Using a suitable hoist, remove torque converter (18) from torque converter housing (19). Place torque converter on a work bench supported by two wooden blocks.

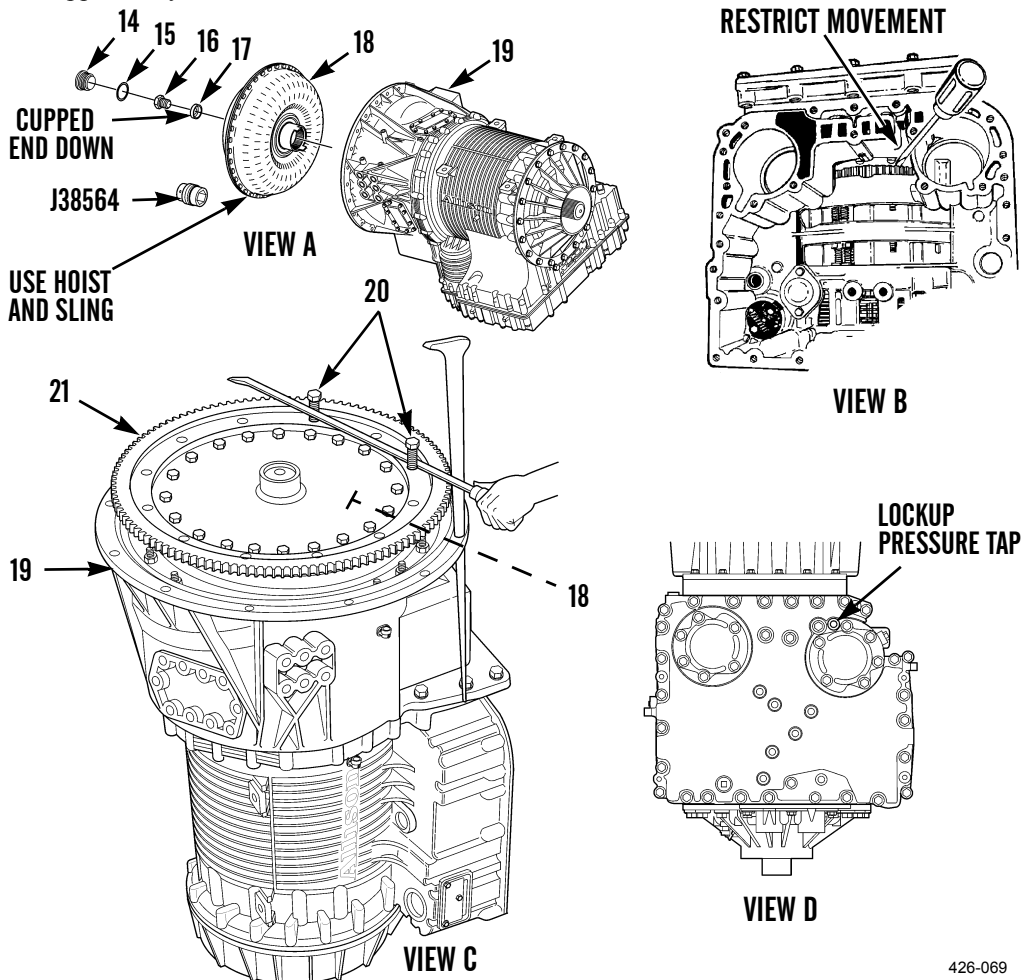

426-069

**DISASSEMBLY - CONTINUED****Removal of Torque Converter Housing Module**

1. Remove 25 bolts (25) securing converter housing (22) to main housing module (24).
2. Attach suitable lifting sling and hoist to converter housing (22).
3. Remove converter housing (22) and gasket (23) from main housing (24). Discard gasket.

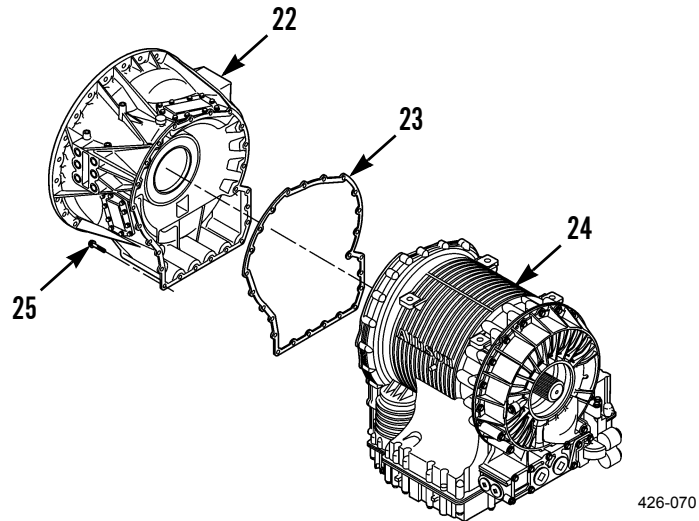

**DISASSEMBLY - CONTINUED**

**Removal of Control Valve Module**



Use extreme caution when handling heavy parts. Provide adequate support and use assistance during procedure. Ensure that any lifting device used is in good condition and of suitable load capacity. Keep clear of heavy parts supported only by lifting device. Failure to follow this warning may result in death or injury to personnel.

1. Remove 43 bolts (28 and 29) and control module (27) from main housing module (24) including bolts retaining filter covers.
2. Loosen control module (27) from main housing (24) by installing jacking screws into control module bolt holes that bottom out against main housing.
3. Remove gasket (26) from control module (27) or from main housing (24). Discard gasket.

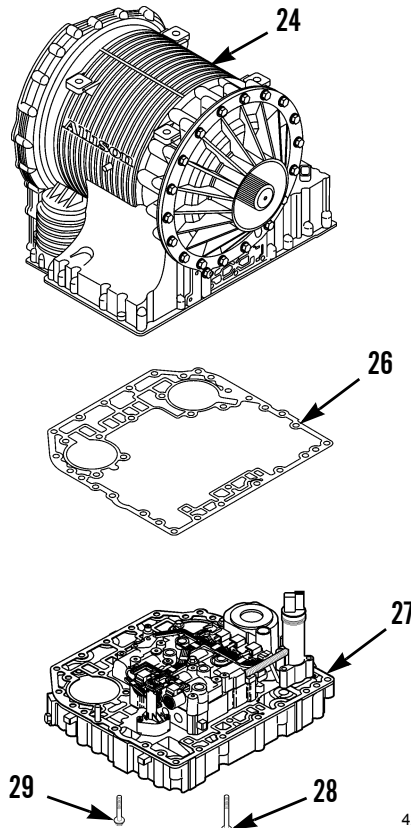

426-071

**DISASSEMBLY - CONTINUED****Removal of Rear Cover Module**

4. Remove 19 bolts (33), washers (32) securing rear cover module (31) to main housing (24).
5. Remove rear cover module (31) and gasket (30) from main housing (24). Discard gasket.

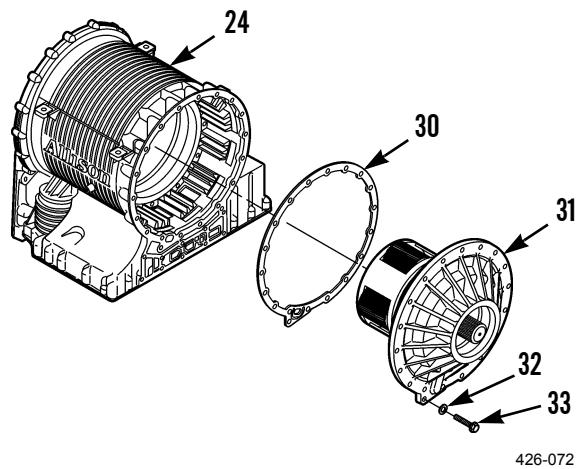
**Removal of Main Shaft Module**

Remove main shaft module assembly (34) with thrust bearing (35) and selective shim (36) from main housing (24). Tag thrust bearing and shim to aid in assembly and identification.

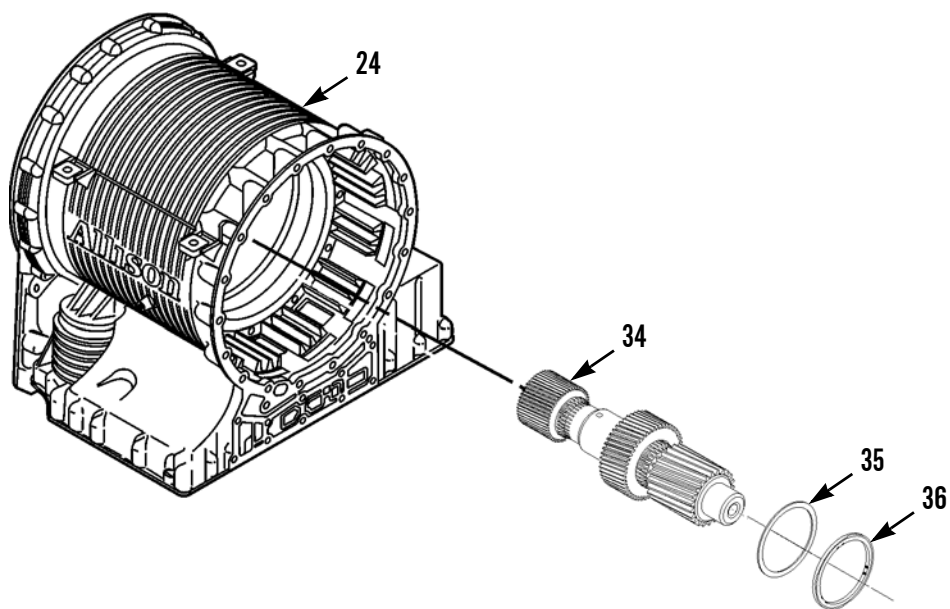

**DISASSEMBLY - CONTINUED****Removal of P2 Planetary Module, C5 Clutch Pack, and P1 Planetary Module**

1. Lift P2 planetary module (37) from main housing (24).
2. Lift C5 clutch pack (38), containing eight friction plates (39) and nine steel reaction plates (40), from main housing (24).
3. Measure, tag, and note thickness and cone of each friction plate (39). Minimum thickness is 0.137 in. (3.48 mm). Maximum allowable cone is 0.010 in. (0.25 mm).
4. Measure, tag, and note thickness and cone of each steel reaction plate (40). Minimum thickness is 0.095 in. (2.41 mm). Maximum allowable cone is 0.010 in. (0.25 mm).
5. Lift P1 planetary module (41) from main housing (24).

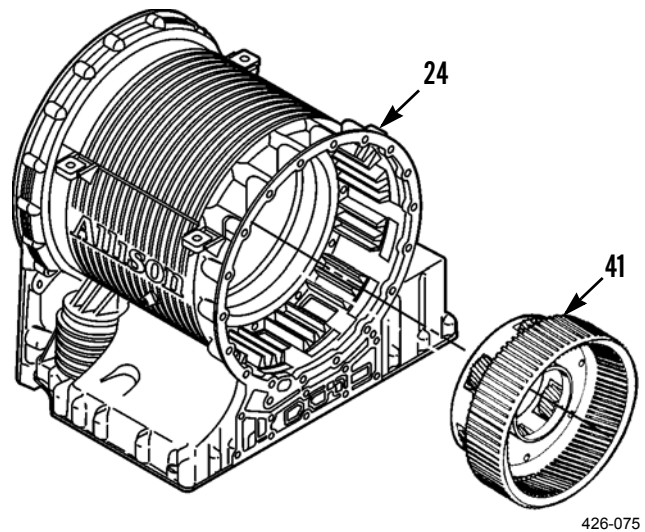
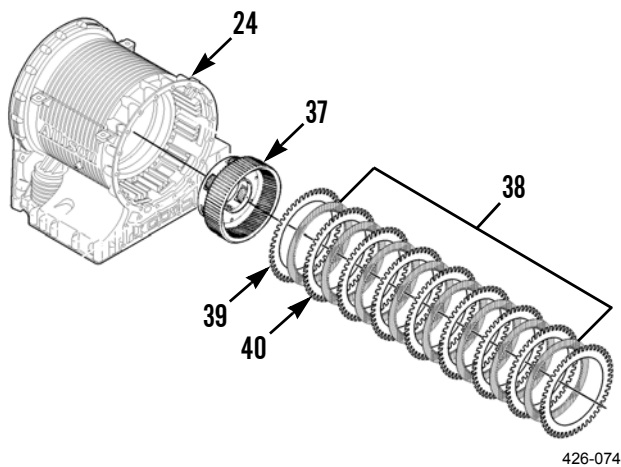



**DISASSEMBLY - CONTINUED****Removal of Front Support/Charging Pump Module and Rotating Clutch Module****NOTE**

Note size and position of 14 bolts securing front support and charging pump module to main housing, to aid during assembly.

1. Remove seven bolts (42) and seven bolts (44) securing front support and charging pump module (43) to main housing (24).
2. Lift front support and charging pump module (43) from main housing (24).
3. Install an M16 lifting eye bolt into turbine shaft (45). Attach a suitable hoist to lifting eye.
4. Using hoist, remove turbine shaft (45) and rotating clutch module (46) from main housing (24).

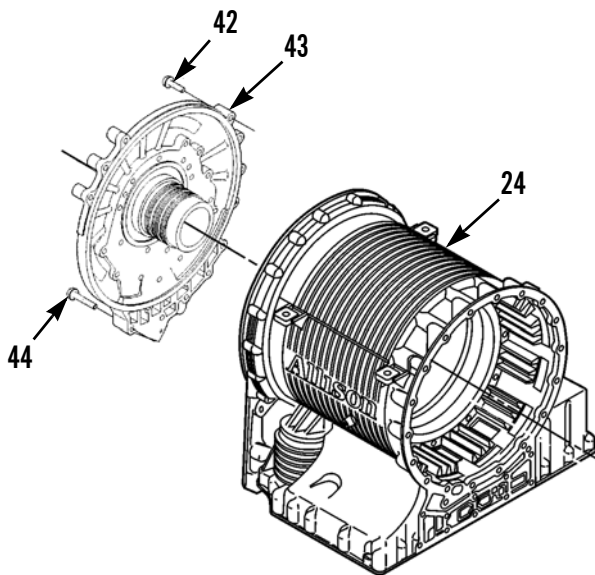

426-076

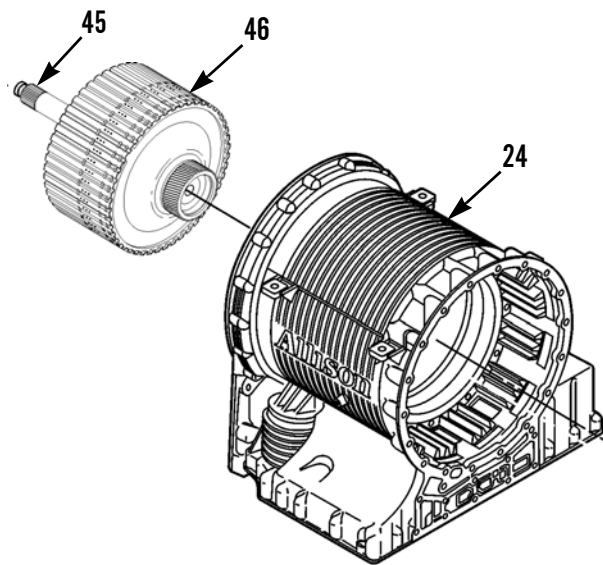

426-077

**Removal of C3/C4 Clutch Assembly**

1. Remove 14 bolts (48) securing C3/C4 clutch assembly (47) in main housing (24).
2. Remove C3/C4 clutch assembly (47) by sliding it out of input end of main housing (24).
3. Inspect and measure C5 clutch plate splines inside main housing (24) for wear. Maximum wear allowed is 0.045 in. (1.15 mm).

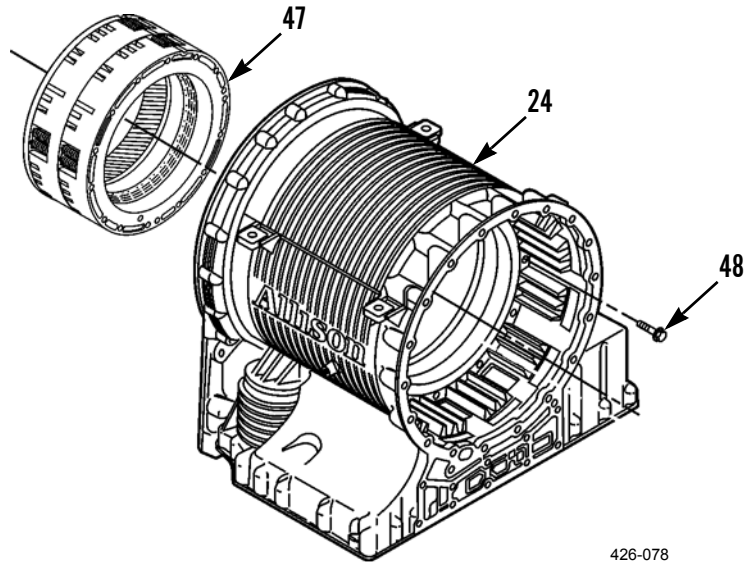

426-078

**MODULE OVERHAUL****Torque Converter Module Disassembly****NOTE**

Prior to disassembling torque converter, note balance marks or mark a line across converter cover to pump assembly with a scribe. These marks will ensure correct assembly of torque converter and reduce balance problems.

1. Place converter assembly (6) on a flat work surface with pump drive tangs downward.
2. Remove 36 nuts (1) from outer diameter of cover assembly (2).
3. Remove 36 T-headed bolts (12) from outer diameter of pump assembly (13).
4. Carefully, without prying, remove cover assembly (2) from pump assembly (13).
5. Remove and discard O-ring (15) from between converter assembly halves.
6. Remove turbine assembly (28) from cover assembly (2).
7. Remove stator assembly (19) from pump assembly (13).
8. Remove thrust bearing race (14) from pump assembly (13).
9. Remove thrust bearing assembly (27) from turbine assembly (28).
10. Remove bearing assembly (16), race (17), and selective shim (18) from pump assembly (13).
11. Remove retaining ring (25) and star plate (26) from stator assembly (19).

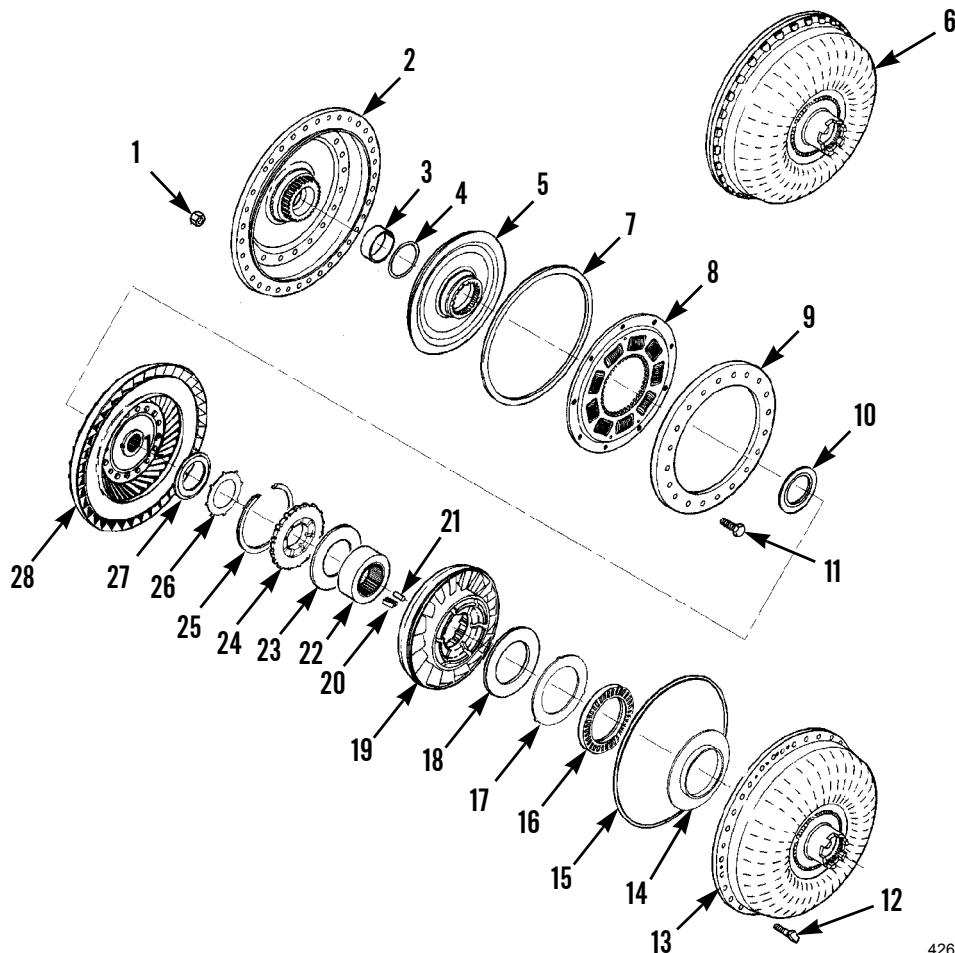

426-079

**MODULE OVERHAUL - CONTINUED****Torque Converter Module Disassembly - Continued**

12. Remove thrust plate (24) from stator assembly (19). Measure, note, and tag thrust plate. Minimum thickness allowed is 0.372 in. (9.45 mm).
13. Remove thrust washer (23) from stator assembly (19).
14. Remove stator race (22), 13 springs (20), and rollers (21). Inspect components for damage.
15. Remove 44 bolts (11) securing lockup clutch backup plate (9) to cover assembly (2). Remove backup plate from cover.
16. Measure thickness of backup plate wear surface. Minimum thickness allowed is 0.464 in. (11.79 mm). Check for backup plate distortion. Maximum distortion allowed is 0.006 in. (0.15 mm).
17. Remove lockup clutch damper assembly (8) from cover assembly (2). Perform the following measurements.
  - a. Lockup clutch thickness: minimum thickness allowed is 0.335 in. (8.51 mm).
  - b. Lockup clutch distortion: maximum allowable distortion is 0.020 in. (0.51 mm).
  - c. Spline wear check: measure between turbine and lockup clutch damper. Maximum allowable wear is 0.015 in. (0.38 mm) on either spline.
18. Remove lockup clutch piston (5), inner seal ring (4), and outer seal ring (7) from cover assembly (2). Measure thickness of lockup clutch piston. Minimum thickness allowed is 0.257 in. (6.53 mm).
19. Inspect and measure inside diameter (ID) of converter cover bushing (3). Maximum allowed inside diameter of bushing is 2.634 in. (66.90 mm). Remove bushing if replacement is necessary.
20. Remove thrust bearing (10) from converter cover (2).

**MODULE OVERHAUL - CONTINUED**

**Torque Converter Module Disassembly - Continued**

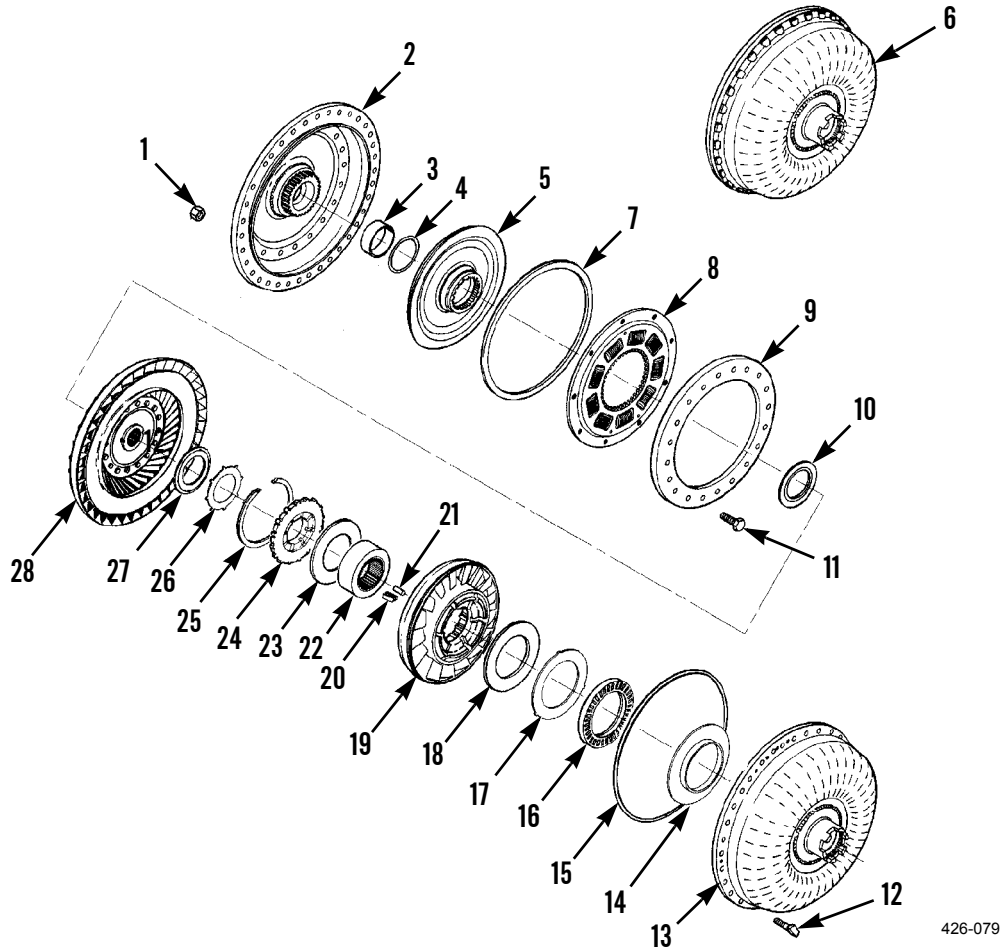

**Torque Converter Module Assembly**

1. Install stator race (22) into stator assembly (19).
2. Install 13 springs (20) and rollers (21) into stator assembly (19). Use petrolatum to help hold springs and rollers in place.

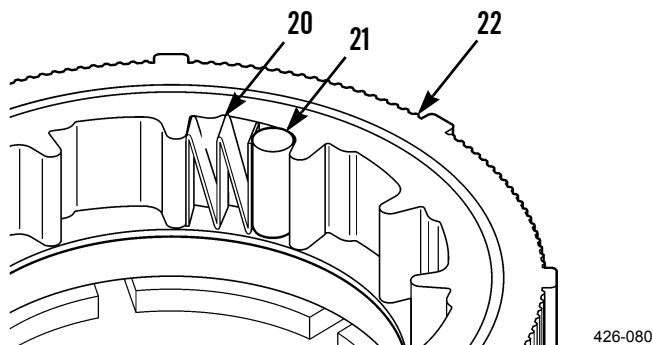

**MODULE OVERHAUL - CONTINUED****Torque Converter Module Assembly - Continued**

3. Install thrust washer (23) and thrust plate (24) on stator assembly (19).
4. Install star plate (26) and retaining ring (25).
5. Install bearing assembly (16), race (17), and selective shim (18) to pump assembly (13).

**CAUTION**

When installing thrust bearings, ensure that locating lip on either inner or outer thrust bearing race is not preventing race from contacting thrust surface of mating part. Failure to follow this caution leads to premature thrust bearing failure and incorrect shim selection to maintain proper internal part clearance.

6. Install thrust bearing assembly (27) into turbine assembly (28).
7. If removed, install new bushing (3) into cover assembly (2), using installer tool (J39949).
8. Insert turbine assembly (28) into converter cover bushing (10). Check for free rotation.
9. Install thrust bearing (10) in cover assembly (2).
10. Install lockup clutch piston inner seal ring (4) on hub of cover assembly (2).
11. Install lockup clutch piston outer seal ring (7) on outside diameter of lockup clutch piston (5).
12. Install lockup clutch piston (5).
13. Install lockup clutch damper assembly (8) in cover assembly (2).
14. Install lockup clutch backup plate (9). Secure backup plate with 44 bolts (11). Tighten bolts to 22-26 lb-ft (30-35 Nm).
15. Install turbine (28) into cover assembly (2), aligning balance mark on turbine with balance mark on lockup clutch damper assembly (8).
16. Install stator assembly (19) in cover assembly (2).
17. Install 36 T-headed bolts (12) into flange of pump assembly (13).
18. Install thrust bearing race (14) into pump assembly (13).
19. Install O-ring (15) onto cover assembly (2).
20. With balance marks aligned, position pump assembly (13) over cover assembly (2).
21. Install four nuts (1) evenly spaced around cover assembly (2) onto T-headed bolts (12). Tighten nuts to 22-26 lb-ft (30-35 Nm).

MODULE OVERHAUL - CONTINUED

Torque Converter Module Assembly - Continued

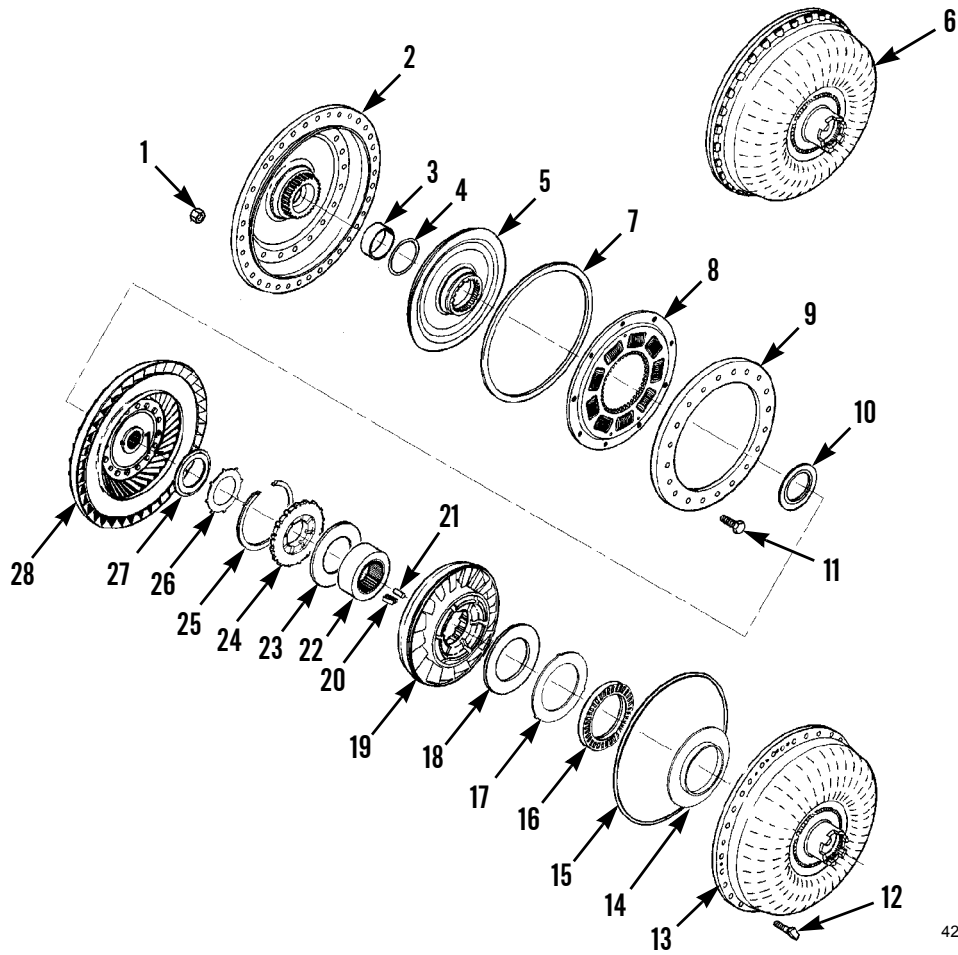

426-079

**MODULE OVERHAUL - CONTINUED**

**Torque Converter Module Assembly - Continued**

**NOTE**

Perform steps 22 through 27 to determine torque converter selective shim dimensions.

22. Using a depth micrometer, measure from top of torque converter drive tang surface to thrust surface of turbine hub. This dimension is "A".
23. Remove bolt from tool (J38548). Install tool into torque converter and position converter on work surface so converter is supported by tool.
24. Using a depth micrometer, measure from top of torque converter drive tang surface to thrust surface of turbine hub. This dimension is "B".
25. Subtract dimension "B" from dimension "A" to get dimension "C".
26. Dimension "C" should be 0.0060-0.0139 in. (0.153-0.353 mm). If dimension is not correct, a shim is required. If the dimension is correct, proceed to step 29.
27. If a shim is required, select appropriate shim from list below:

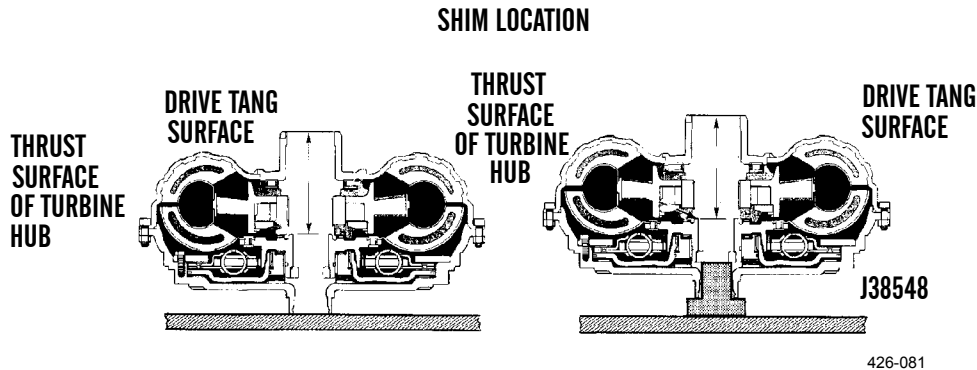

Dimension C	Use P/N	Shim Thickness
0.0140-0.0229 inch (0.356-0.581 mm)	29503879	0.009-0.011 inch (0.23-0.27 mm)
0.0230-0.0319 inch (0.585-0.810 mm)	29503880	0.018-0.020 inch (0.46-0.50 mm)
0.0320-0.0394 inch (0.813-1.000 mm)	29503881	0.027-0.029 inch (0.69-0.73 mm)

28. Disassemble torque converter and install selected shim. Repeat step 22 through 27 to confirm dimension "C".
29. Install remaining 32 nuts (1) and tighten to 22-26 lb-ft (30-35 Nm).



**MODULE OVERHAUL - CONTINUED****Torque Converter Housing Module Disassembly**

1. Remove ten bolts (11), PTO cover (10), and gasket (9). Discard gasket.
2. Remove 11 bolts (1) securing bearing retainer assembly (2) and PTO gear (12) assembly to converter housing (8).
3. Remove seal rings (3 and 4) from bearing retainer (2). Discard seal rings.
4. Remove bearing retainer oil seal (15) using tool (J24171-A). Discard oil seal.
5. Inspect bushing (14) for damage or wear. Maximum allowable bushing ID is 3.511 in. (89.19 mm). Remove if damaged or worn.
6. Remove oil pump drive hub (5) from PTO gear (12).
7. Inspect oil pump drive hub (5) for excessive wear on drive tangs. Maximum allowable tang wear is 0.012 in. (0.31 mm).
8. Remove seal ring (7) from PTO gear (12).
9. Inspect PTO gear bearings (6 and 13). If damaged, remove and discard.

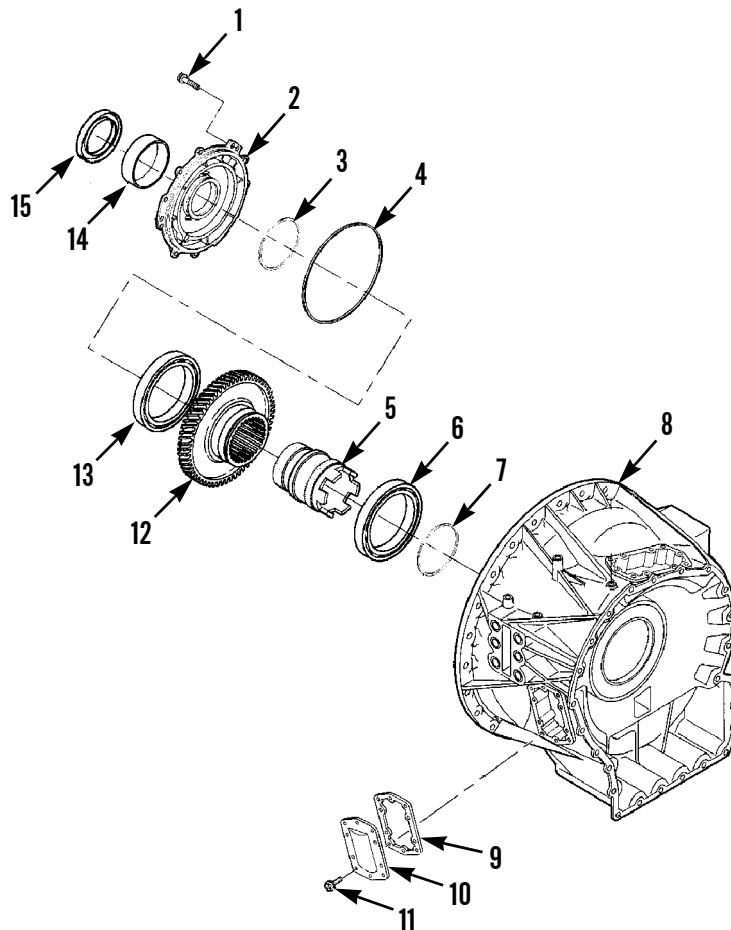

426-082

**MODULE OVERHAUL - CONTINUED****Torque Converter Housing Module Assembly**

1. If PTO gear bearings (6 and 13) were discarded, install new bearings using tool (J37041).

**CAUTION**

Oil pump drive hub can be incorrectly installed backwards. Position oil pump drive hub tangs toward oil pump.

2. Install oil pump drive hub (5) into PTO gear (12), aligned with hub tangs toward oil pump.

**NOTE**

Butt-joint seal rings require special handling during assembly. Seal rings contain materials that absorb moisture from atmosphere, causing them to expand. Check seal ring end clearance before installation to ensure seal ring has not expanded.

3. Install seal ring (7) into seal ring bore of torque converter pump housing and measure end gap with feeler gage. Seal ring end gap must be 0.047-0.065 in. (1.19-1.65 mm). If seal ring is not within tolerance, ring has expanded and must be replaced.
4. Remove seal ring (7) from pump housing seal ring bore and install onto PTO gear (12).
5. If removed, install bearing retainer bushing (14) using press and tools (J37038 and J8092).
6. Install new seal ring (4) onto bearing retainer (2) and install new oil seal (15) using press and tools (J37032 and J37034).
7. Install new seal ring (3) into seal ring bore in PTO gear (12) and measure end gap with thickens gage.
8. Seal ring (3) end gap must be 0.047-0.065 in. (1.19-1.65 mm). If seal ring is not within tolerance, ring has expanded and must be replaced.
9. Remove seal ring (3) from seal ring bore in PTO gear (12) and install seal ring onto bearing retainer (2).
10. Using a mallet, lightly tap PTO gear (12) assembly into converter housing (8) until gear assembly is seated.
11. Use guide bolts to install bearing retainer assembly (2), rocking retainer while installing into converter housing (8).
12. Install 11 bolts (1) to secure bearing retainer assembly (2) and PTO gear (12) assembly into converter housing (8). Tighten bolts to 38-45 lb-ft. (51-61 Nm).
13. Install PTO cover (10) and new gasket (9) with ten bolts (11). Tighten bolts to 38-45 lb-ft (51-61 Nm).

**MODULE OVERHAUL - CONTINUED**

**Torque Converter Housing Module Assembly - Continued**

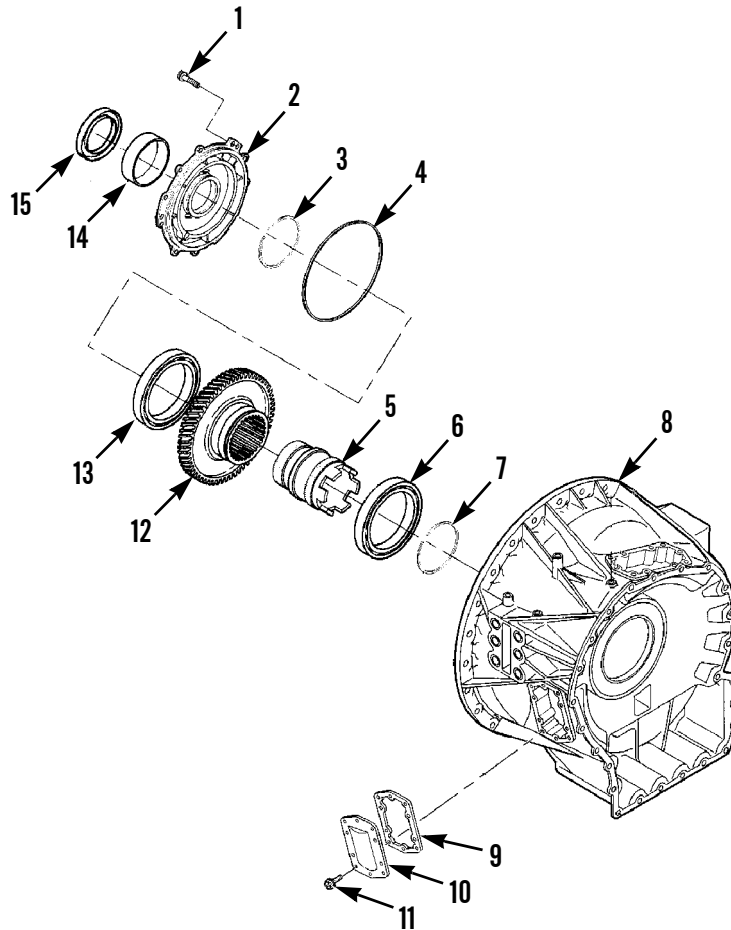

426-082

**MODULE OVERHAUL - CONTINUED**

**Front Support and Charging Oil Pump Module Disassembly**

1. Remove three seal rings (18) from hub of front support assembly (10).
2. Remove eight bolts (16) securing pump housing assembly (4) to front support assembly (10).
3. Remove pump housing (4) and gear set (5 and 6) from front support (10).
4. Remove O-ring (1) and oil seal assembly (2) using tool J24171-A.

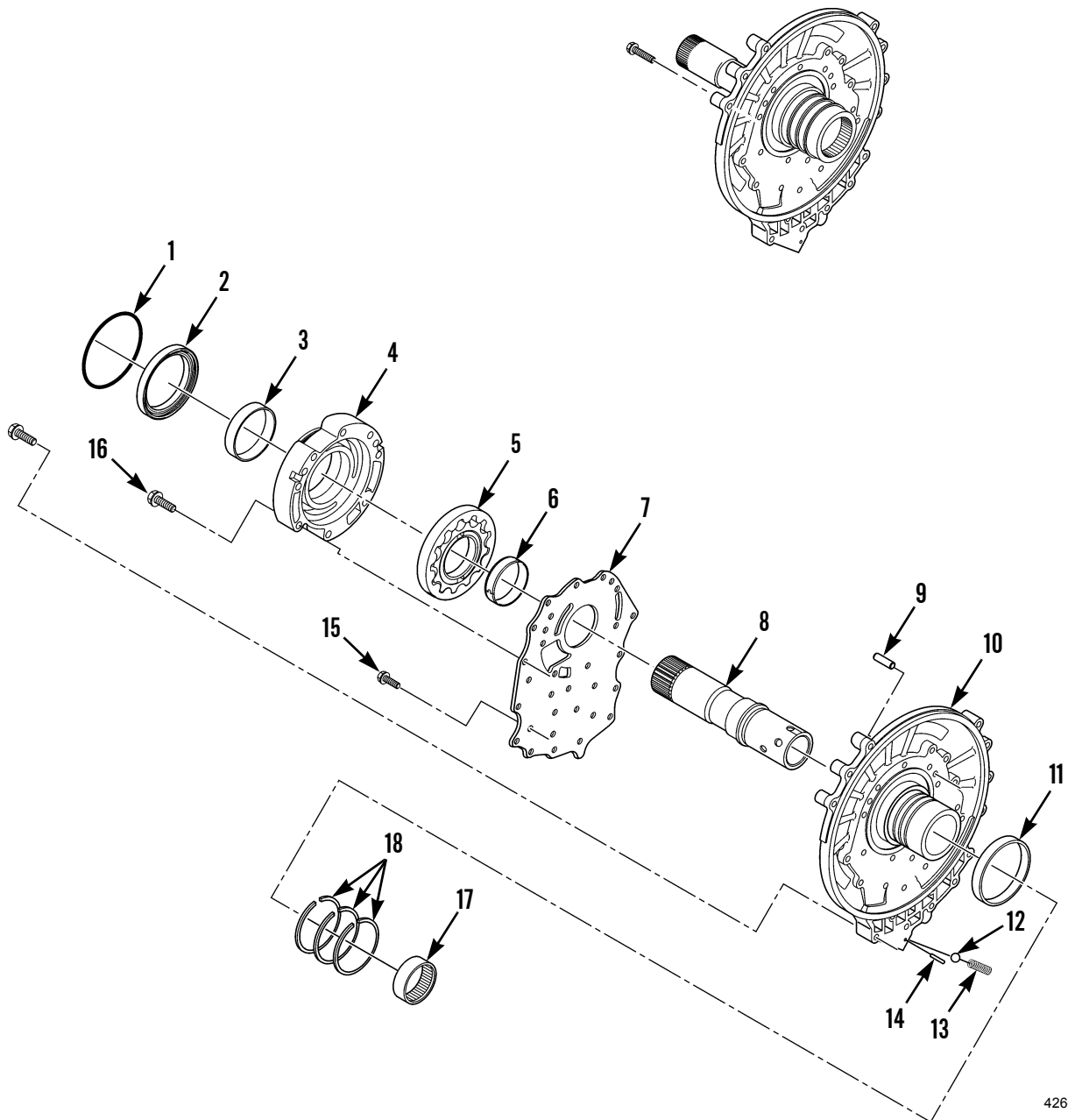

426-083

**MODULE OVERHAUL - CONTINUED**

**Front Support and Charging Oil Pump Module Disassembly - Continued**

5. Measure gear cavity depth of pump housing. Maximum depth allowed is 0.75 in. (19.04 mm).

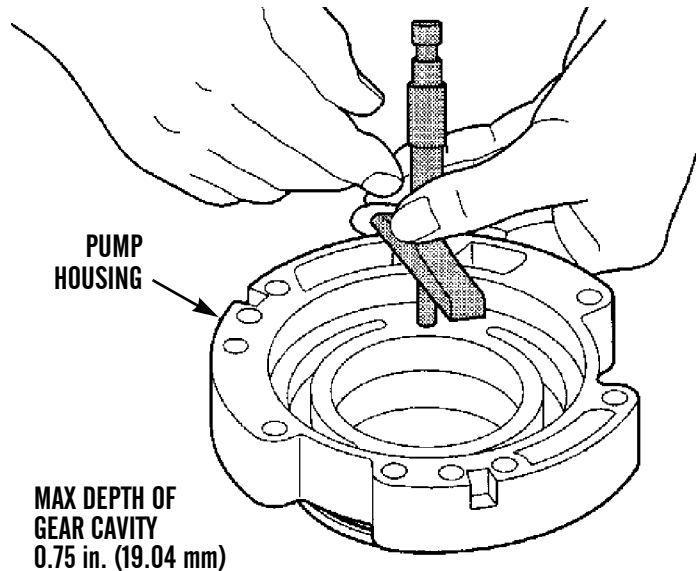

6. Measure gear cavity diameter of pump housing (4). Maximum depth allowed is 5.915 in. (150.25 mm).

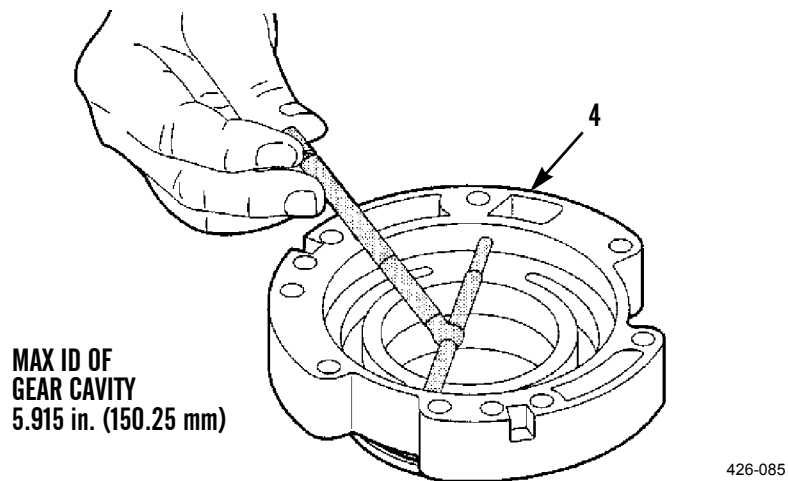

**MODULE OVERHAUL - CONTINUED**

**Front Support and Charging Oil Pump Module Disassembly - Continued**

7. Measure inside diameter of bushing (3) inside pump housing (4). Maximum inside diameter allowed is 3.511 in. (89.19 mm). Replace bushing if worn or damaged.
8. Install gear set (5 and 6) into pump housing (4). Measure pump gear side clearance of both gears. Maximum allowable clearance is 0.004 in. (0.10 mm).

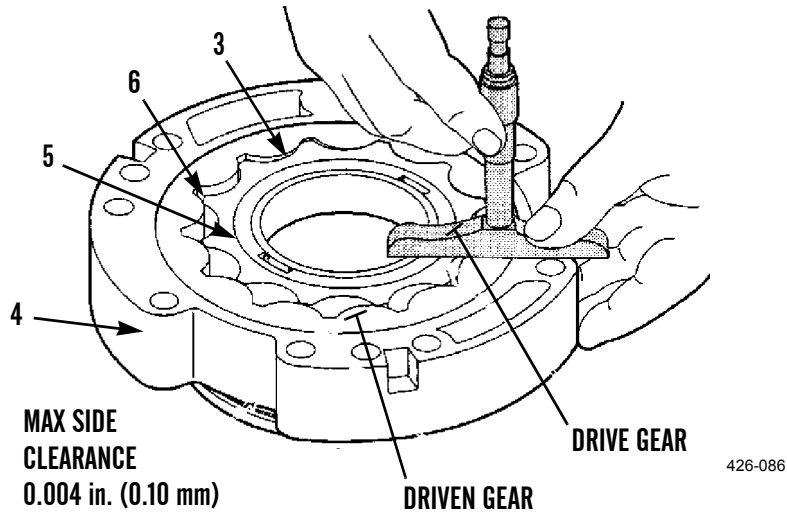

9. Measure gear tooth tip clearance. Maximum allowable clearance is 0.006 in. (0.15 mm).

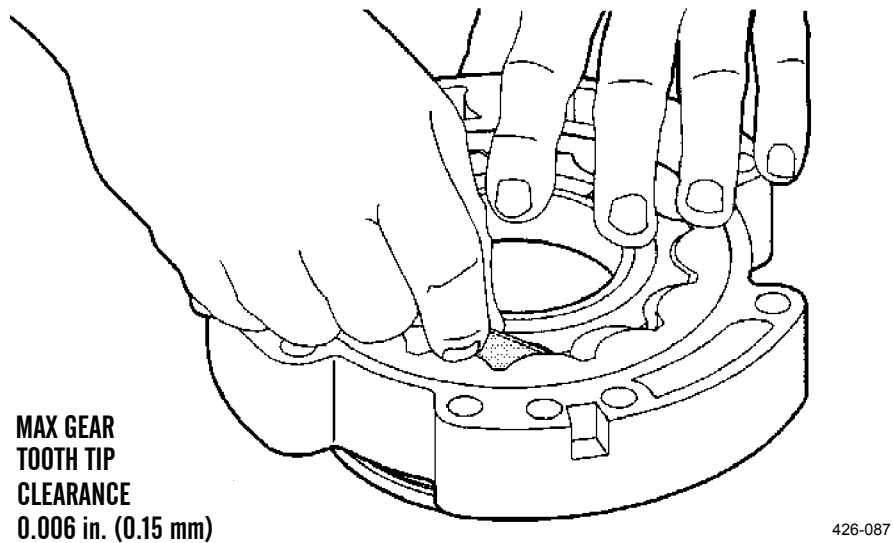

**MODULE OVERHAUL - CONTINUED****Front Support and Charging Oil Pump Module Disassembly - Continued**

10. Measure driven gear to pump housing clearance. Maximum allowable clearance is 0.012 in. (0.30 mm).

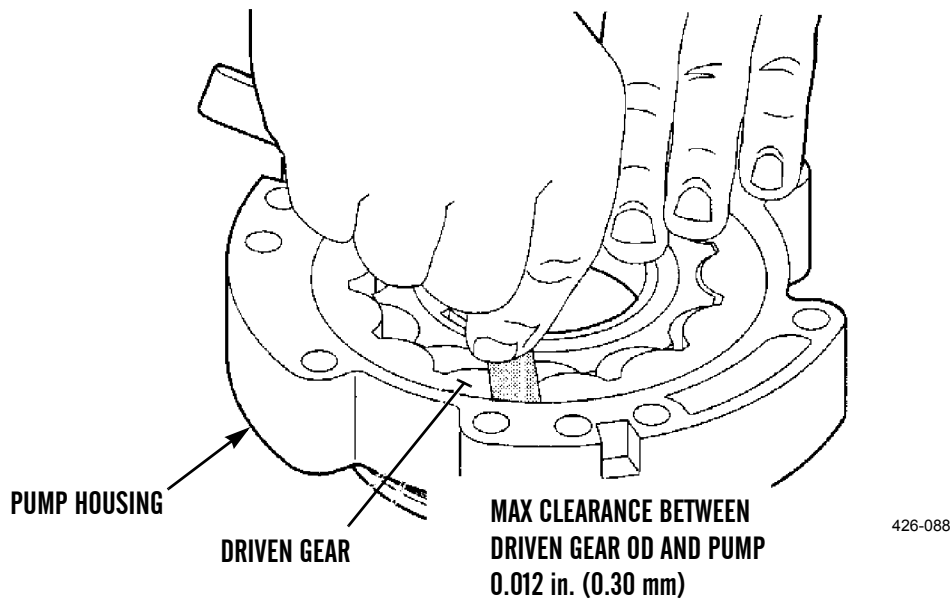

11. Inspect and measure bushing (6) inside inner gear of gear set (5). The maximum ID of bushing is 2.635 in. (66.93 mm). If bushing is damaged or out of tolerance, remove.
12. Remove 14 bolts (15) securing wear plate (7) to front support (10). Remove wear plate.
13. Inspect roller bearing (17). If damaged, remove using drift and hammer.
14. Inspect and measure front support sleeve (11). Minimum OD diameter of front support sleeve is 4.717 in. (119.81 mm). If sleeve is damaged or out of tolerance, remove.
15. Inspect front support dowel pins (9). If damaged, remove.
16. Inspect ground sleeve (8). If damaged or worn, press from front support (10).
17. Using tool (J41462), compress spring (13) until load is removed from dowel pin (14). Remove dowel pin and carefully release load on spring by rotating handle on tool in counterclockwise direction. When spring has reached its free length, remove tool. Remove spring and ball (12) from front support (10). Check spring tension in accordance with Table 3, Wear Limits and Spring Data, located at the end of this work package.
18. Inspect ball seat area of front support (10) for damage. If damage is found, replace front support.

MODULE OVERHAUL - CONTINUED

Front Support and Charging Oil Pump Module Disassembly - Continued

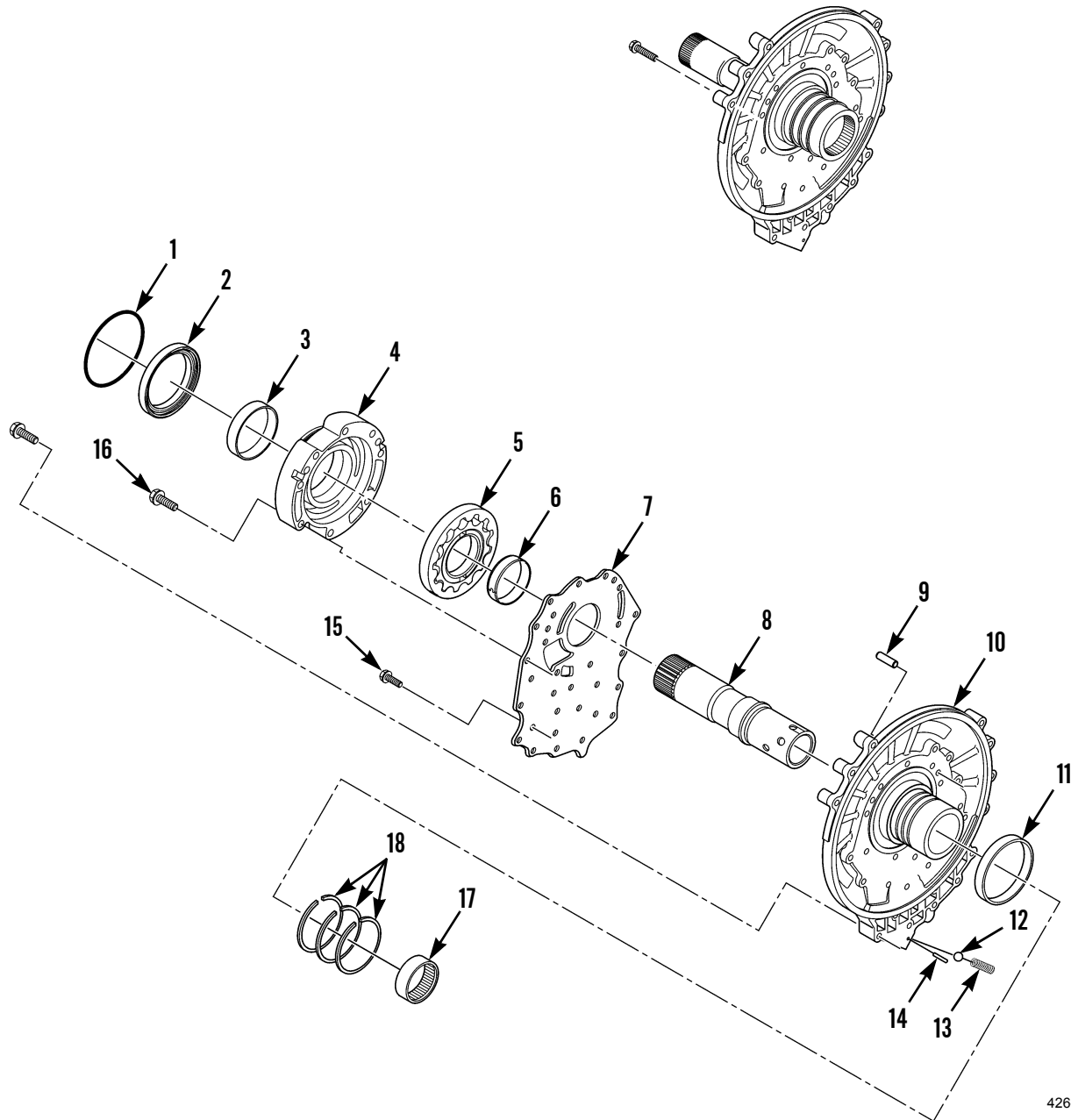

426-083



**MODULE OVERHAUL - CONTINUED****Front Support and Charging Oil Pump Module Assembly**

1. Replace front support (10) if damage to ball seat or other area is found.
2. Replace spring (13) if spring load did not meet load specifications.
3. Install ball (12) and spring (13) into front support (10). Compress spring using tool J41462 until dowel pin (14) can be inserted to retain spring.
4. Install ground sleeve (8). Place front support (10) on press bed. Machined flat at base of ground sleeve must align with "up" arrow cast on front support.
5. Press ground sleeve (8) into front support (10) to shoulder. Total runout of spline outside diameter must not exceed 0.005 in. (0.13 mm).
6. Install dowel pins (9). Press pins to height of 0.57 in. (14.5 mm) from surface of front support (10).
7. Align lubrication hole in sleeve (8) with relief valve bore (bottom of front support), and install sleeve using a press and tools J37041 and J37034.
8. Install wear plate (7) and 14 bolts (15). Tighten bolts to 38-45 lb-ft (51-61 Nm).
9. Install bearing (17) using a press and tools J37038 and J8092. Press bearing flush to 0.010 in. (0.25 mm) below surface.
10. Install bushing (6) into pump housing using a press and tools J37038 and J8092.
11. Install oil seal (2) using a press and tools J37032 and J37034.
12. Install O-ring (1).
13. Install bushing (6) into drive (inner) gear of gear set (5). Align staking in pore-staked bushing with slots in inside gear of gear set. Use tool 39954.
14. Lubricate pump gear set (5) and install gear set in pump housing (4).
15. Install pump housing (4) to front support (10) with eight bolts (16). Tighten bolts to 38-45 lb-ft (51-61 Nm).
16. Measure end gap of three rotating sealrings (18) before installation. Insert sealrings into rotating clutch hub bore and measure end gap with a feeler gauge. Sealring end gap MUST BE 0.040-0.056 in. (1.00-1.44 mm).
17. Install three rotating sealrings (18) on front support (10) hub.

**MODULE OVERHAUL - CONTINUED**

**Rotating Clutch Module Disassembly**

1. Remove thrust bearing (5) and retaining ring (19) from rotating clutch module (9). Inspect thrust bearing. If worn, discard.
2. Remove P1 sun gear assembly (21) and thrust bearing (20) from rotating clutch module (9).
3. Remove C2 retaining ring (22) and backplate (23).
4. Measure wear surface thickness of C2 backplate (23). Minimum thickness allowed is 0.311 in. (7.90 mm). Check flatness of backplate. Maximum allowable distortion is 0.006 in. (0.15 mm).

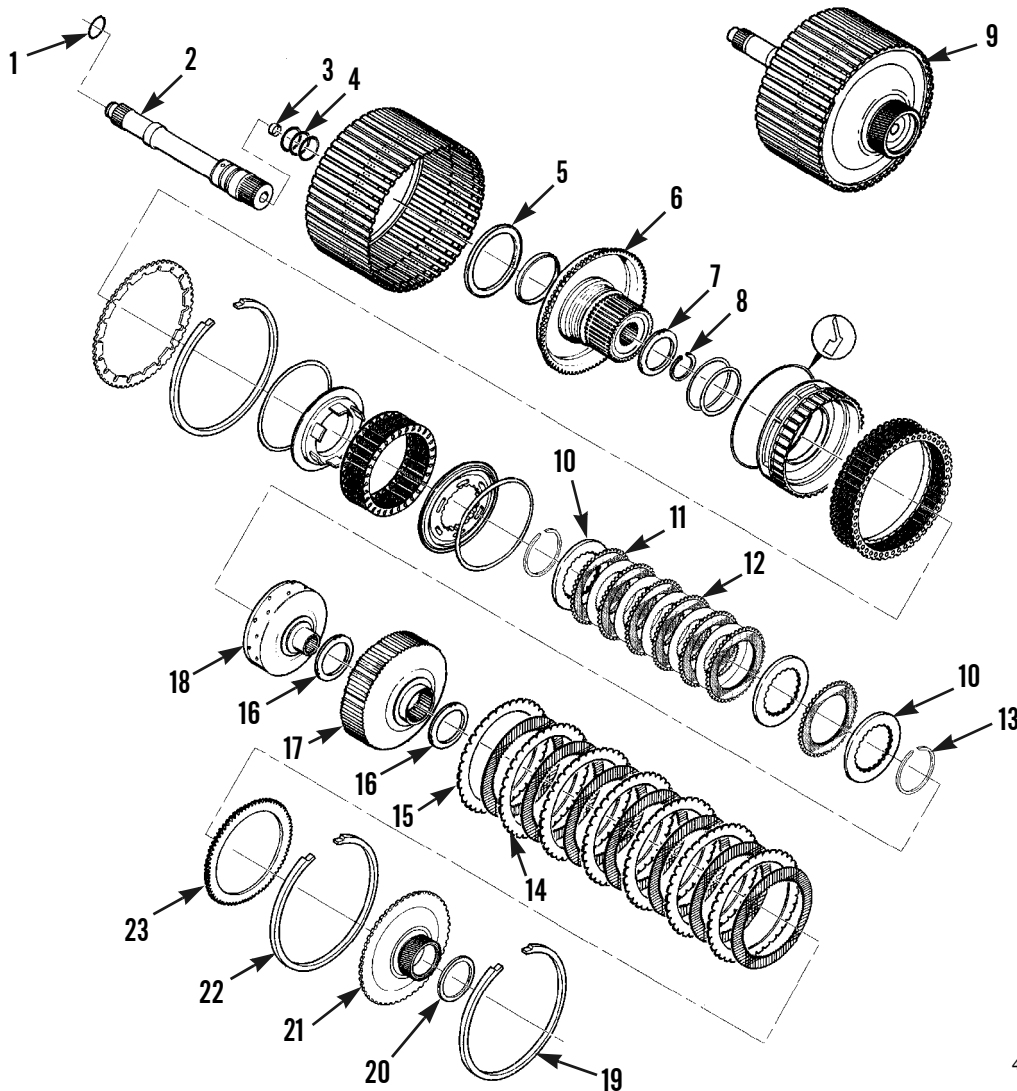

426-090

5. Remove C2 clutch pack containing seven friction plates (14) and seven steel reaction plates (15). Perform the following measurements:
  - a. Friction plate thickness: minimum thickness allowed is 0.115 in. (2.92 mm).
  - b. Friction plate oil groove depth: minimum depth allowed is 0.008 in. (0.20 mm).

**MODULE OVERHAUL - CONTINUED****Rotating Clutch Module Disassembly - Continued**

- c. Friction plate cone: maximum cone allowed is 0.010 in. (0.25 mm).
- d. Reaction plate thickness: minimum thickness allowed is 0.095 in. (2.41 mm).
- e. Reaction plate cone: maximum cone allowed is 0.010 in. (0.25 mm).
6. Remove C2 (17) and C1 (18) drive hubs with two thrust bearings (16). Measure drive hub splines. Maximum allowable spline wear is 0.015 in. (0.38 mm).
7. Remove C1 retaining ring (13), two backplates (10), seven friction plates (11), and six steel reaction plates (12). Perform the following measurements:
  - a. Friction plate thickness: minimum thickness allowed is 0.115 in. (2.92 mm).
  - b. Friction plate oil groove depth: minimum depth allowed is 0.008 in. (0.20 mm).
  - c. Friction plate cone: maximum cone allowed is 0.010 in. (0.25 mm).
  - d. Reaction plate thickness: minimum thickness allowed is 0.095 in. (2.41 mm).
  - e. Reaction plate cone: maximum cone allowed is 0.010 in. (0.25 mm).
  - f. Backplate thickness: minimum thickness allowed is 0.311 in. (7.90 mm).
  - g. Backplate flatness: maximum allowable distortion is 0.006 in. (0.15 mm).
8. Remove thrust bearing (7) from clutch hub assembly (6).
9. Remove retaining ring (8) and turbine shaft (2) from clutch hub (6).
10. Inspect and measure bushing (3) inside end of turbine shaft (2). Maximum ID allowed is 1.423 in. (36.14 mm).
11. Remove three seal rings (4) and O-ring (1) from turbine shaft (2). Discard O-ring.

**MODULE OVERHAUL - CONTINUED**

**Rotating Clutch Module Disassembly - Continued**

**WARNING**

The rotating clutch piston springs are highly compressed and must be properly released. Failure to follow this warning may result in personnel injury.

12. Place rotating clutch (9) on tool base (J37030-3) so rotating drum is supported by tool tangs (View C).
13. Install tool (J35923-2) with bearing, washer, and handle. Tighten tool, compressing C1 balance piston (33) and C1 spring assembly (34). Remove retaining ring (31) (View A).

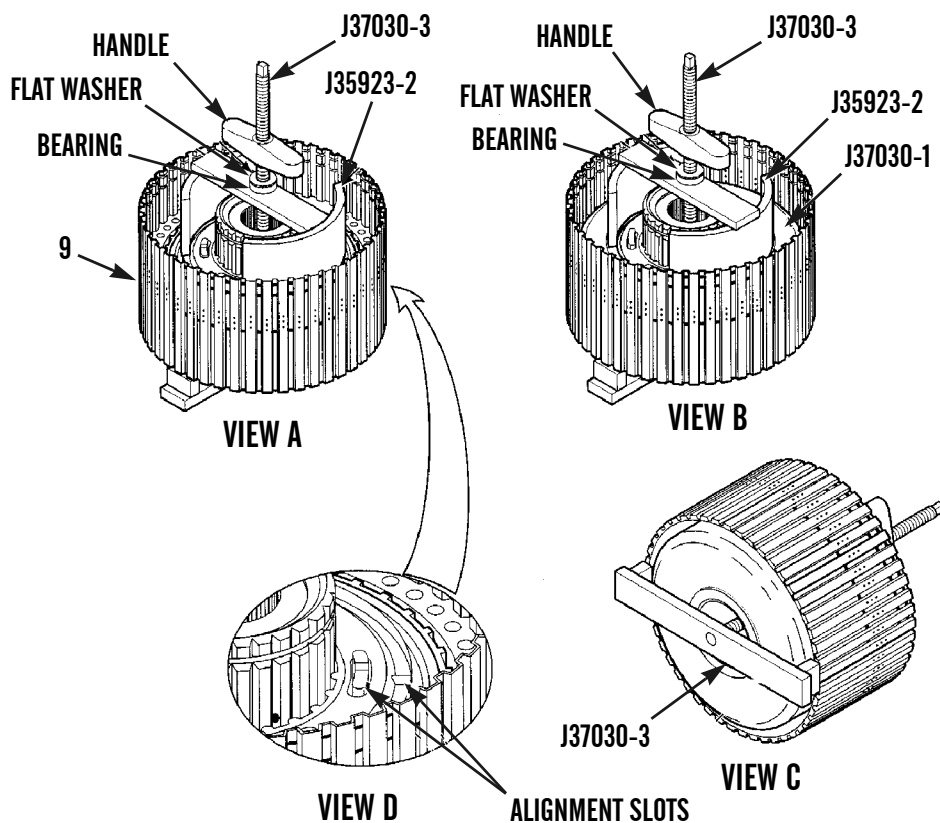

426-091

14. Release spring tension by rotating handle in counterclockwise direction. Remove tool (J35923-2) with bearing, washer, and handle.
15. Remove C1 balance piston (33), seal ring (32), and C1 spring assembly (34).
16. Install tools (J37030-3, J37030-1, and J35923), bearing, washer, and handle. Tighten tool and remove retaining ring (37). Remove tools after relieving spring tension. Remove spring assembly (30) and spring plate (38) (View B).

**MODULE OVERHAUL - CONTINUED**

**Rotating Clutch Module Disassembly - Continued**

17. Lift rotating drum (24) from clutch hub (6) and C1/C2 pistons (29 and 35). Inspect clutch splines of rotating drum. Maximum spline wear allowed is 0.015 in. (0.38 mm).
18. Remove C1/C2 pistons (29 and 35) and seal rings (28 and 36) from clutch hub (6), by rocking pistons from side to side.
19. Inspect and measure ID of rotating clutch hub housing bushing (25). Maximum allowable ID of bushing is 4.735 in. (120.27 mm). Remove bushing from clutch hub (6) if replacement is necessary. Avoid damaging bushing bore.
20. Remove piston seal rings (26 and 27) from clutch hub (6).
21. Separate C1 piston (35) and seal ring (36) from C2 piston (29) and seal ring (28) by lightly tapping on C1 piston.

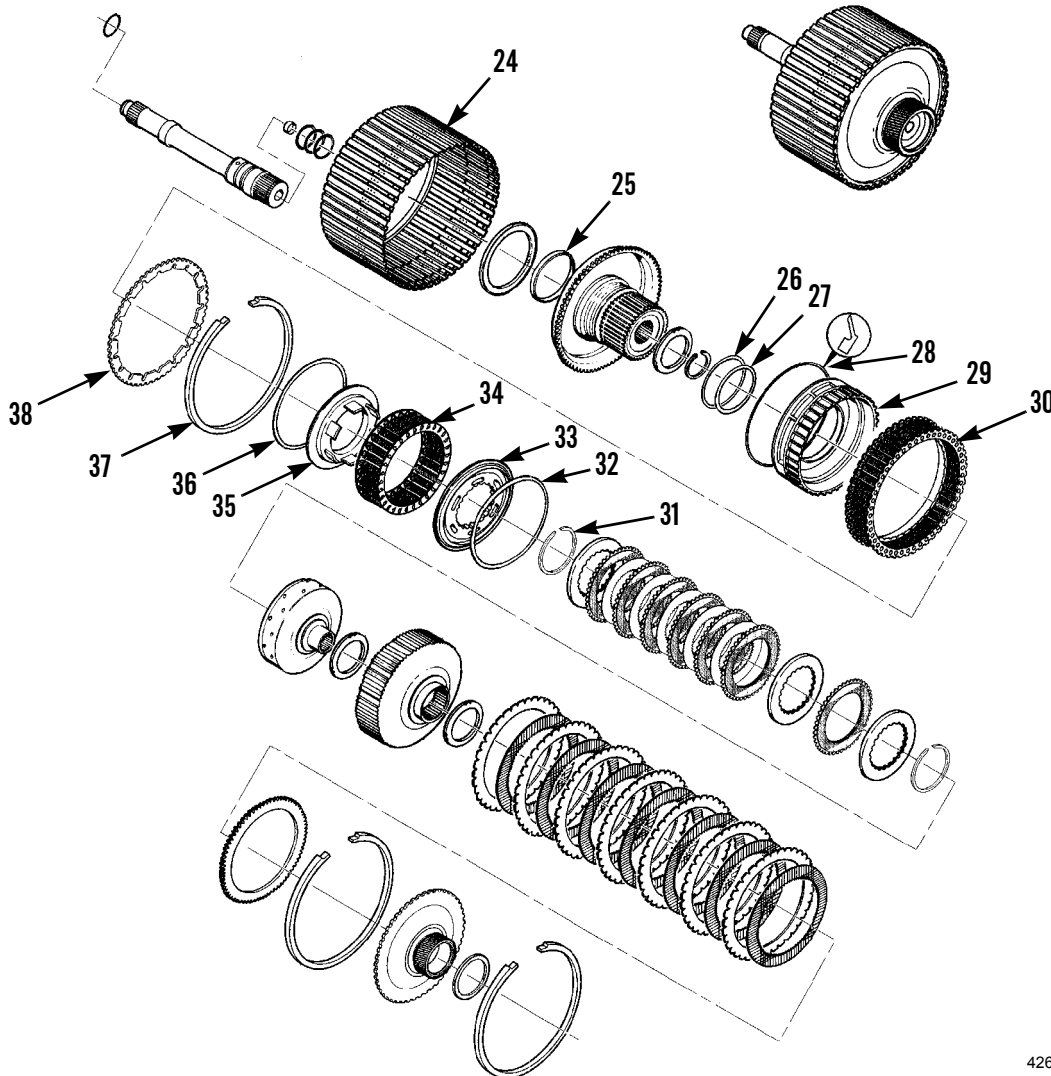

426-090

**MODULE OVERHAUL - CONTINUED****Rotating Clutch Module Assembly**

1. If rotating clutch hub bushing (25) was removed, install new bushing using tool (J37040).
2. Install piston seal ring (26) on clutch hub (6), and piston seal ring (27) into C2 piston (29). Install clutch hub and piston seal ring (36) into C1 piston (35).
3. With a mallet, lightly tap C2 piston (29) into clutch hub (6).
4. Align notch on C1 piston (35) with lubrication orifice on rotating drive hub. With a mallet, lightly tap C1 piston onto center of C2 piston (29) and over clutch hub (6).
5. Install rotating drum (24) over clutch hub (6) and C1/C2 pistons (29 and 35).
6. Install C2 spring assembly (30). Index spring assembly with drive hub tangs and splines on C2 piston (29). Ensure C2 spring assembly has made contact with bottom of slots in C2 piston. If spring assembly did not reach bottom, remove spring assembly and reannex in next spline on rotating drum. Repeat this process until C2 spring is in proper position.
7. Install C2 spring plate (38). Index spring plate with drive hub tangs and splines on C2 piston (29).

**WARNING**

The rotating clutch piston springs are highly compressed and must be properly released. Failure to follow this warning may result in personnel injury.

8. Place rotating clutch on tool base (J37030-3) so that rotating drum is supported by tool tangs. Install tool (J37030-1 and J35923-2), that includes bearing, washer, and handle. Tighten tool to compress C2 spring assembly (30) and install retaining ring (37) (View B, page 0083 00-24). Remove tools.
9. Install seal ring (32) onto balance piston (33).
10. Install C1 spring assembly (34). Align mark on balance piston (33) with slot on C1 piston (35). Position balance piston onto the C1 piston.
11. Install tool (J35923-2) with bearing, washer, and handle. Tighten tool, compressing C1 balance piston (33) and C1 spring assembly (34). Install retaining ring (31) (View A, page 0083 00-24). Remove tools.
12. If turbine shaft bushing (3) was removed, replace using tool (J37036).
13. Lubricate with transmission oil and install new O-ring (1) on turbine shaft (2).

**NOTE**

Butt-joint seal rings require special handling during assembly. Seal rings contain materials that absorb moisture from atmosphere causing them to expand. Check seal ring end clearance before installation to ensure seal ring has not expanded.

14. Install each rotating seal ring (4) into ground sleeve bore and measure end gap. Seal ring end gap must be 0.026-0.040 in. (0.65-1.01 mm). Install three rotating seal rings with correct end gap, into rear of turbine shaft (20).
15. Install turbine shaft (2) and retain with retaining ring (8).

**CAUTION**

Ensure thrust bearing is assembled with locating lip on either inner or outer thrust bearing race not preventing race from contacting thrust surface of mating part. Failure to follow this caution leads to thrust bearing failure and incorrect shim selection to maintain proper part clearance.

16. Install thrust bearing (7) on rotating clutch hub (6).

**MODULE OVERHAUL - CONTINUED**

**Rotating Clutch Module Assembly - Continued**

17. Install C1 clutch pack: first install one backplate (10), then alternately install friction (11) and steel reaction plates (12), starting with a friction plate and ending with a backplate. Secure clutch pack in place with retaining ring (13).
18. Install C1 drive hub (18) over clutch pack while aligning external splines.
19. Install thrust bearing (16) on each side of C2 drive hub (17), then position this group over C1 drive hub (18).
20. Install C2 clutch plates, alternating between friction plates (14) and steel reaction plates (15), starting with steel reaction plates.
21. Install C2 backplate (23) and retaining ring (22).
22. Install thrust bearing (20) on sun gear (21).
23. Install P1 sun gear assembly (21) and retaining ring (19).
24. Install thrust bearing (5) on rotating clutch module (9).

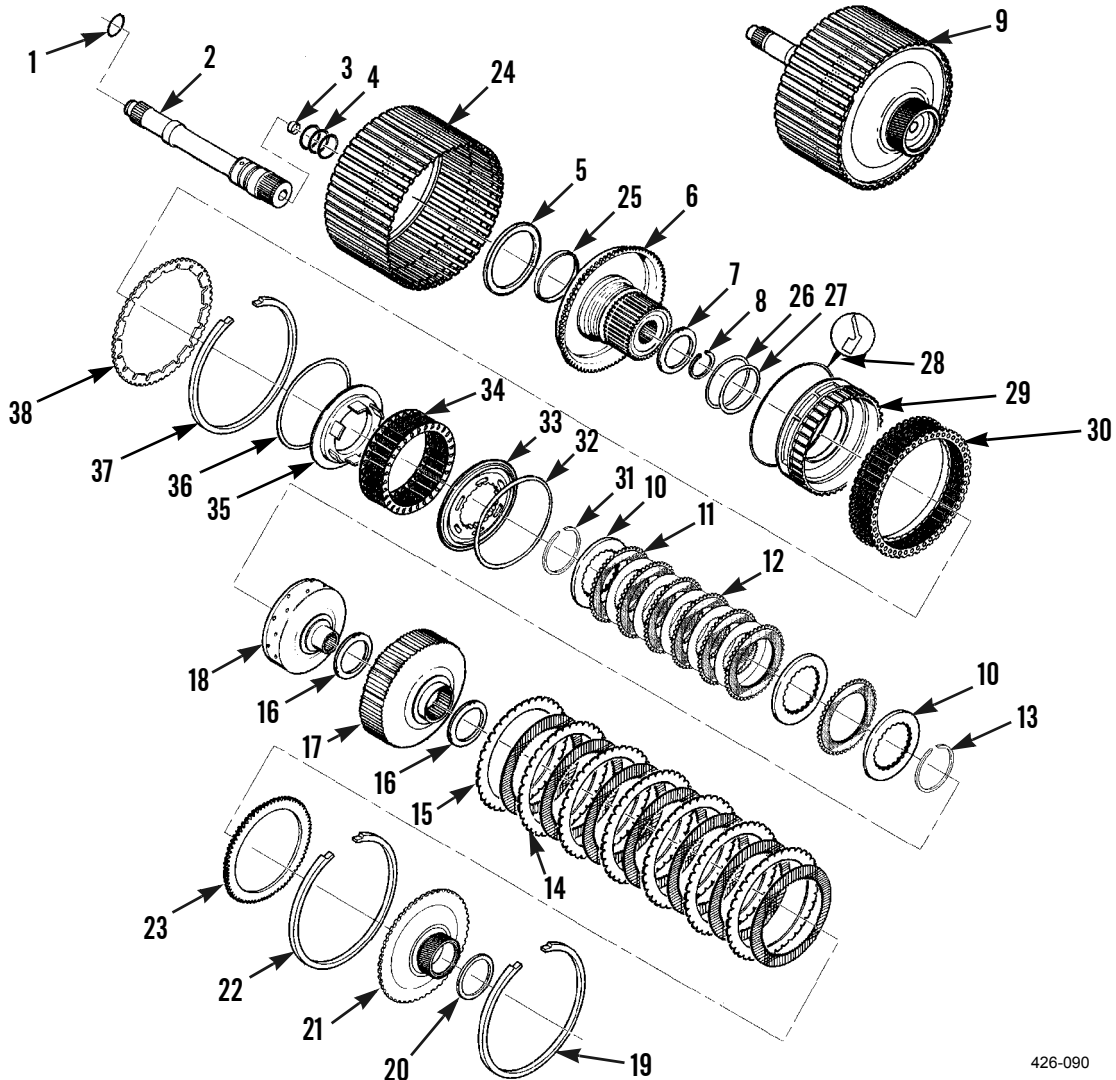

426-090

**MODULE OVERHAUL - CONTINUED****C3/C4 Clutch Assembly and Main Housing Module Disassembly**

1. Remove rivets (17) and nameplate (16) if damaged.
2. Inspect inner C5 clutch plate splines of main housing (18). Maximum allowable spline wear is 0.045 in. (1.15 mm).
3. Remove 14 bolts (1) and C3 backplate (2).
4. Inspect and measure four thrust plates (3) and C3 backplate (2). Perform the following measurements:
  - a. Thrust plate thickness at contact surface: minimum allowable thickness is 0.111 in. (2.82 mm).
  - b. Backplate distortion: maximum allowable distortion is 0.006 in. (0.15 mm).
  - c. Backplate step wear: maximum allowable wear is 0.005 in. (0.13 mm).
5. Remove P1 ring gear (4) and inspect clutch splines of P1 ring gear. Maximum allowable spline wear is 0.015 in. (0.38 mm).
6. Remove and measure C3 clutch pack: five friction plates (5) and four steel reaction plates (6). Perform the following measurements:
  - a. Friction plate thickness: minimum allowable thickness is 0.137 in. (3.48 mm).
  - b. Friction plate: maximum allowable cone is 0.010 in. (0.25 mm).
  - c. Steel reaction plate thickness: minimum allowable thickness is 0.128 in. (3.25 mm).
  - d. Steel reaction plate: maximum allowable cone is 0.010 in. (0.25 mm).
7. Remove piston return plate (7).
8. Inspect and measure piston return plate (7). Minimum allowable thickness of plate is 0.193 in. (4.91 mm).
9. Remove C3 clutch piston (8).
10. Remove and inspect six thrust plates (9) in C3 housing (10). Perform the following measurements:
  - a. Thrust plate thickness: minimum allowable at contact surface is 0.111 in. (2.82 mm).
  - b. Backplate distortion: maximum allowable is 0.006 in. (0.15 mm). Maximum allowable stepwear is 0.005 in. (0.13 mm).
  - c. Spline wear in housing: maximum allowable is 0.045 in. (1.15 mm).
11. Remove and measure C4 clutch pack: five friction plates (15) and six steel reaction plates (14). Perform the following measurements:
  - a. Friction plate thickness: minimum allowable thickness is 0.137 in. (3.48 mm).
  - b. Friction plate: maximum allowable cone is 0.010 in. (0.25 mm).
  - c. Steel reaction plate thickness: minimum allowable thickness is 0.128 in. (3.25 mm).
  - d. Steel reaction plate: maximum allowable cone is 0.010 in. (0.25 mm).
12. Remove and inspect piston return plate (13). Minimum allowable thickness 0.193 in. (4.91 mm).



**MODULE OVERHAUL - CONTINUED**

**C3/C4 Clutch Assembly and Main Housing Module Disassembly - Continued**

13. Remove piston (12) from C4 housing (11). Inspect splines in housing. Maximum spline wear allowed is 0.045 in. (1.15 mm).

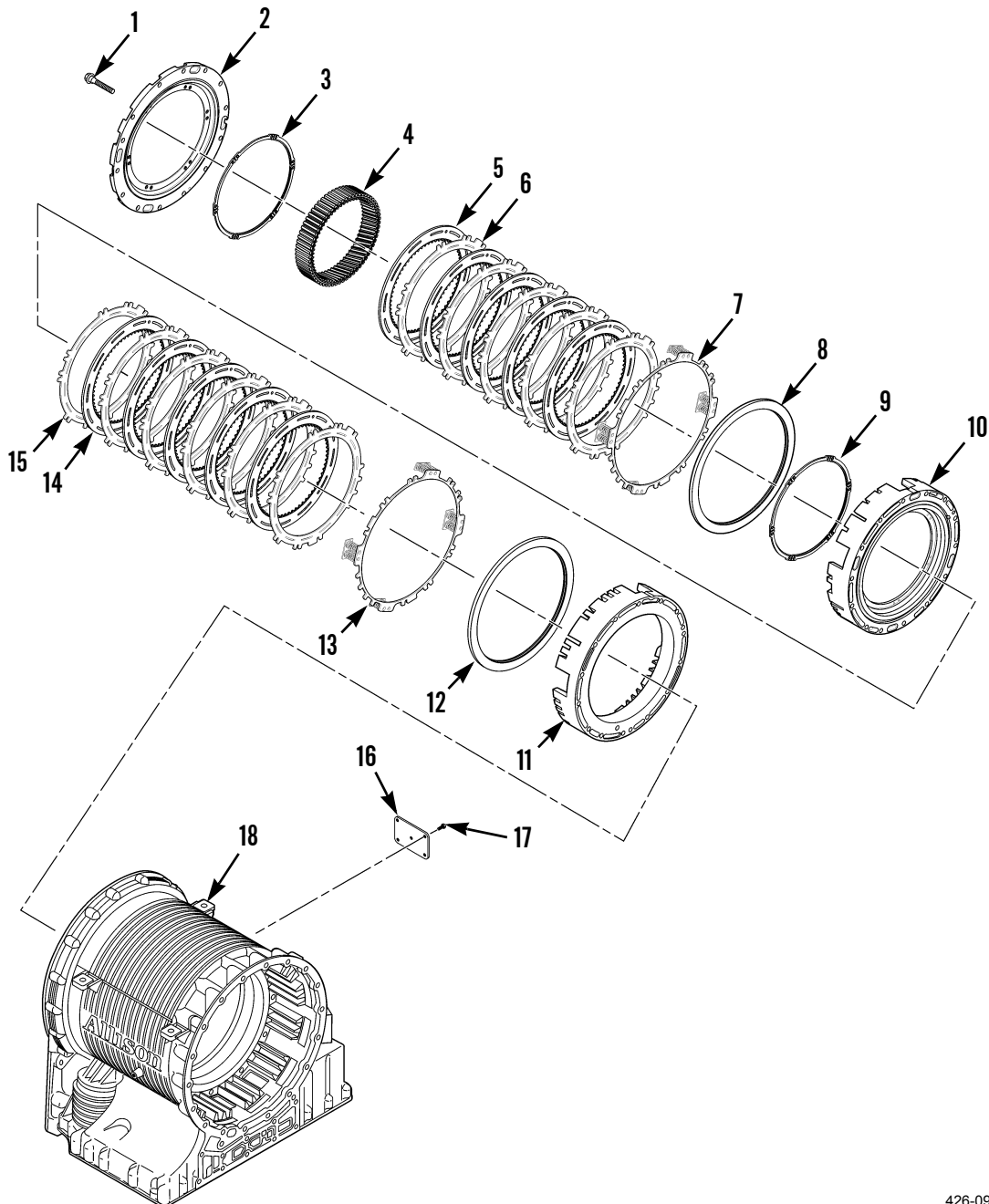

426-092

**MODULE OVERHAUL - CONTINUED****C3/C4 Clutch Assembly and Main Housing Module Assembly**

1. Install piston (12) into C4 housing (11).
2. Install piston return plate (13).
3. Install C4 clutch pack, starting with a friction plate (15). Alternately install five friction plates and six steel reaction plates (14).
4. Install six thrust plates (9) into C3 clutch housing (10). Thrust plates must be tightly attached to housing; no movement is allowed.
5. Install C3 clutch piston (8) into C3 clutch housing (10).
6. Install C3 clutch housing (10) with clutch piston (8) on top of assembled C4 clutch housing (11). Ensure index notches on clutch housings are aligned.
7. Install piston return plate (7).
8. Install P1 ring gear (4).
9. Install C3 clutch pack: starting with a friction plate (5), alternately install five friction plates and five steel reaction plates (6).
10. Install four thrust plates (3) into C3 backplate (2). Thrust plate **MUST BE** tightly attached to backplate; no movement is allowed.
11. Install C3 backplate assembly (2), aligning notches on C3 and C4 housings.
12. Install 14 bolts (1) into C3/C4 clutch assembly. Tighten bolts to 38-45 ft-lb (51-61 Nm).
13. Install nameplate (16) and rivets (17) if removed.

**MODULE OVERHAUL - CONTINUED**

**C3/C4 Clutch Assembly and Main Housing Module Assembly - Continued**

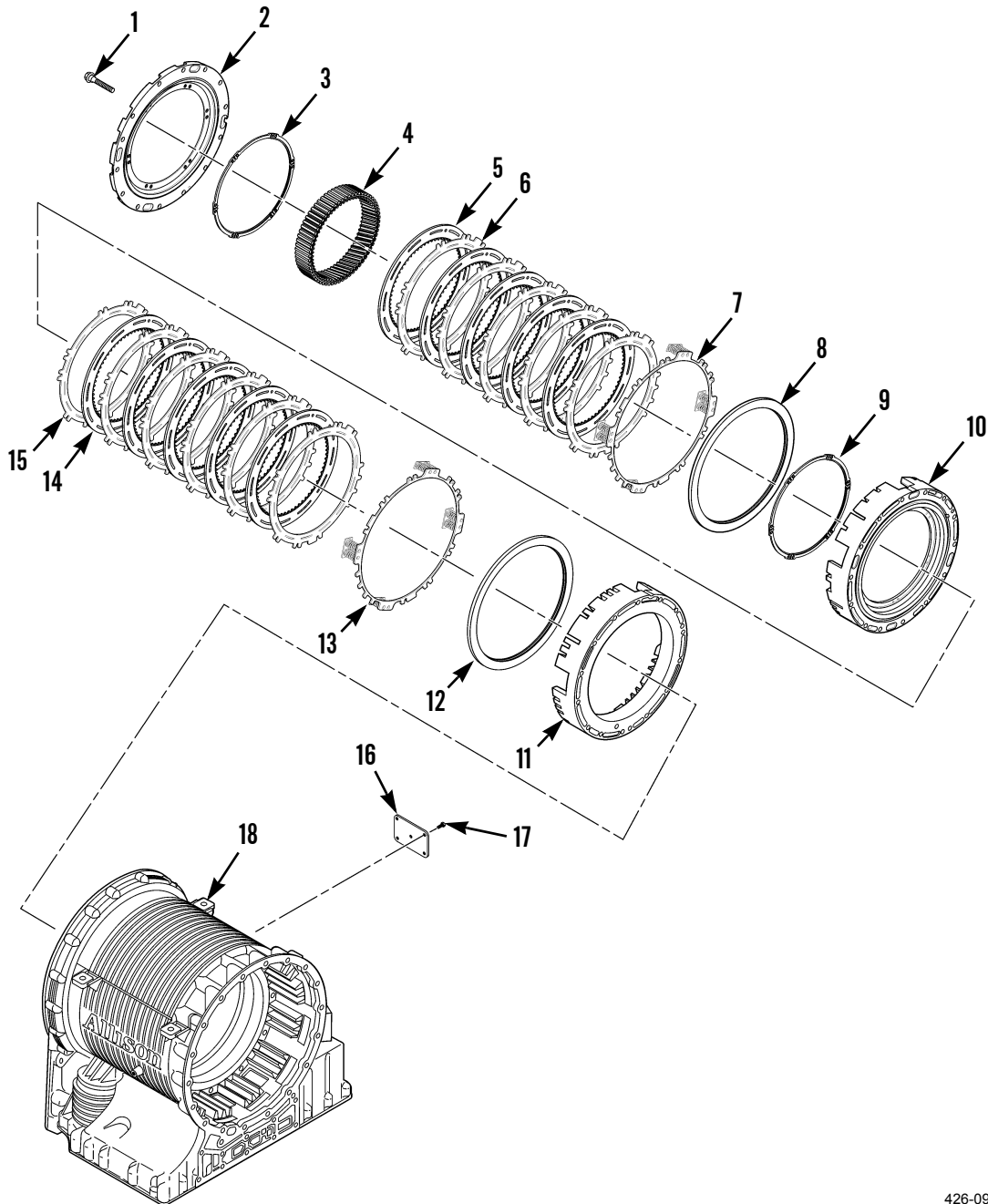

426-092

**MODULE OVERHAUL - CONTINUED****Main Shaft Module Disassembly**

1. Remove external spiral retaining ring (1) and P2 sun gear (2) from main shaft (6).
2. Remove bearing spacer (3), thrust bearing (5), and selective shim (4) from main shaft (6).
3. Inspect and measure main shaft (6). Inspect for evidence of wear, chipped or cracked splines or teeth. Measure main shaft in accordance with Table 2, Wear Limits Data, located at the end of this work package.

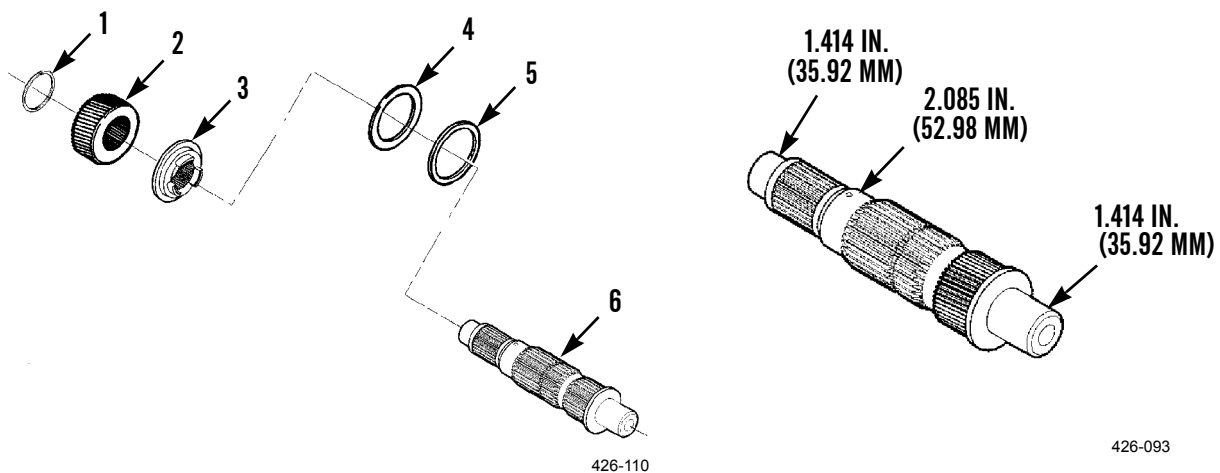
**Main Shaft Module Assembly****NOTE**

Do not install thrust bearing (5) and selective shim (4) until final transmission assembly. Measurement for selective shim is performed during final buildup.

1. Install bearing spacer (3) on main shaft (6).
2. Install P2 sun gear (2) and external spiral retaining ring (1) on main shaft (6).

**P1 Planetary Module Disassembly**

1. Remove internal retaining ring (1) from P2 planetary ring gear (5) and remove P2 planetary ring gear from planetary module (2).
2. Check P1 planetary carrier assembly (3) for pinion end play. Pinion end play must not exceed 0.037 in. (0.94 mm). Check all six pinion gears.
3. Remove retaining ring (13) and indexing ring (12).
4. Remove six pinion spindles (11) from P1 planetary carrier (3).
5. Remove pinion gear (9), thrust washers (7 and 10), and two bearing assemblies (8) from side of P1 planetary carrier (3). Repeat procedure for remaining pinion gears.
6. Measure thickness and step wear of thrust washers (7 and 10). Minimum thrust washer thickness allowed is 0.055 in. (1.40 mm). Maximum step wear allowed is 0.005 in. (0.12 mm).
7. Remove thrust bearing (4) from P1 planetary carrier (3).

**MODULE OVERHAUL - CONTINUED**

**P1 Planetary Module Disassembly - Continued**

8. Inspect and measure bushing (6) inside P1 planetary carrier (3) for wear or damage. Maximum ID allowed is 3.516 in. (89.32 mm). If bushing is worn, remove and replace.
9. Check spline wear of P1 planetary carrier (3) and P2 planetary ring gear (5). Maximum allowed spline wear is 3.015 in. (0.38 mm).

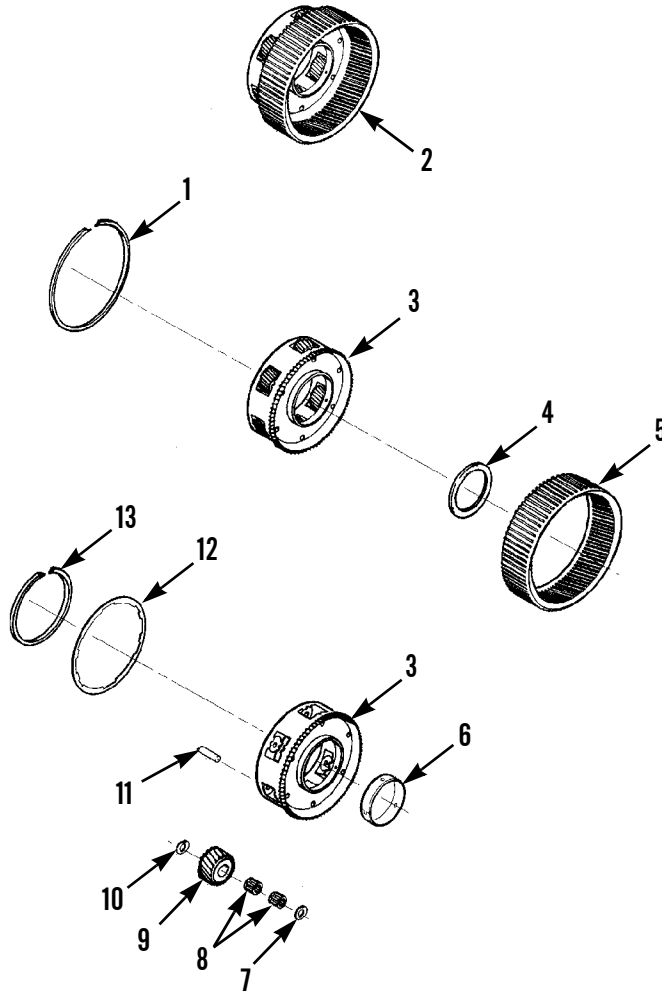

426-094

**MODULE OVERHAUL - CONTINUED**

**P1 Planetary Module Assembly**

1. If removed, install bushing (6) into P1 planetary carrier (3) using a press and tool (J37038). Press new bushing flush to 0.016 in. (0.40 mm) below surface.
2. Install two bearing assemblies (8) into center of pinion gear (9). Install thrust washers (7 and 10) inside P1 planetary carrier (3), align thrust washer tangs with slots in planetary, and retain them with petrolatum. Slide pinion gear and bearing assemblies into side of P1 planetary carrier between thrust washers. Repeat procedure for remaining five pinion gears.
3. Install six spindles (11) so that lower step is positioned for proper installation of indexing ring (12).
4. Install indexing ring (12) and retaining ring (13) to secure pinion gears in place.
5. Measure pinion end play. Pinion end play must not exceed 0.037 in. (0.94 mm). Check all six pinion gears.
6. Install P2 planetary ring gear (5) over P1 planetary carrier assembly (3).
7. Install internal retaining ring (1) into P2 planetary ring gear (5), connecting P1 planetary carrier assembly (3) and P2 planetary ring gear.

**CAUTION**

Ensure thrust bearing is assembled with locating lip on either inner or outer thrust bearing race not preventing race from contacting thrust surface of mating part. Failure to follow this caution leads to thrust bearing failure and incorrect shim selection to maintain proper part clearance.

8. Install thrust bearing (4) on P1 planetary carrier (3).

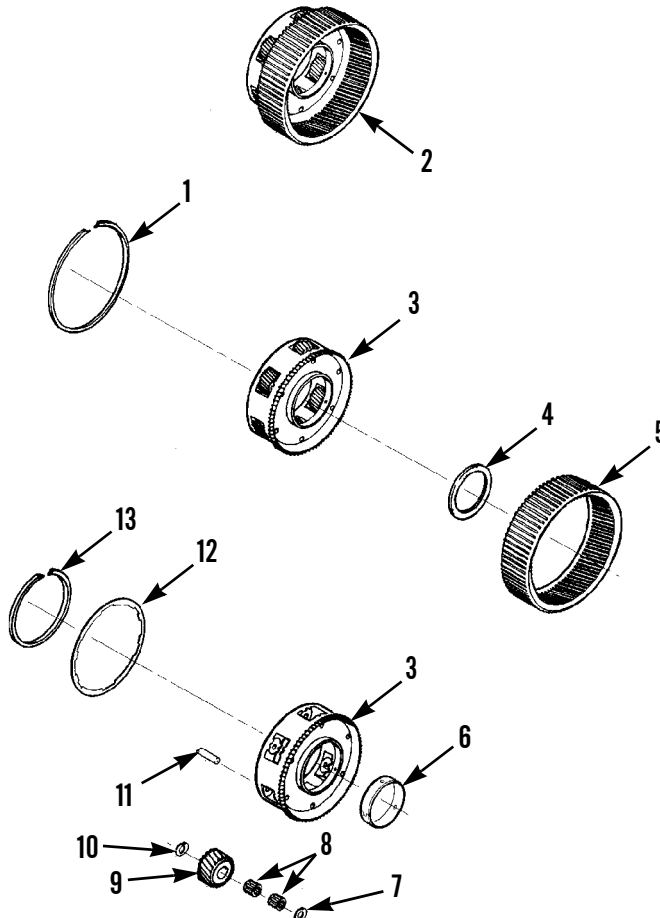

426-094

**MODULE OVERHAUL - CONTINUED****P2 Planetary Module Disassembly**

1. Remove retaining ring (1) and P3 planetary ring gear (4) from planetary module (3). Remove and inspect thrust bearing (5).
2. Check P2 planetary carrier assembly (2) for pinion end play. Pinion end play must not exceed 0.037 in. (0.94 mm). Check all six pinion gears.
3. Remove internal retaining ring (13), indexing ring (12), and four pinion spindles (7) from P2 planetary carrier (2).
4. Remove pinion gear (9), thrust washers (8 and 11), and two bearing assemblies (10) from side of P2 planetary carrier (2). Repeat procedure for remaining pinion gears.
5. Measure thickness and step wear of thrust washers (8 and 11). Minimum thrust washer thickness allowed is 0.055 in. (1.40 mm). Maximum step wear allowed is 0.005 in. (0.12 mm).
6. Inspect and measure bushing (6) inside P2 planetary carrier (2) for wear or damage. Maximum ID allowed is 2.096 in. (53.23 mm). If bushing is worn, remove and replace.
7. Check spline wear of P2 planetary carrier (2) and P3 planetary ring gear (4). Maximum allowed spline wear is 0.015 in. (0.38 mm).

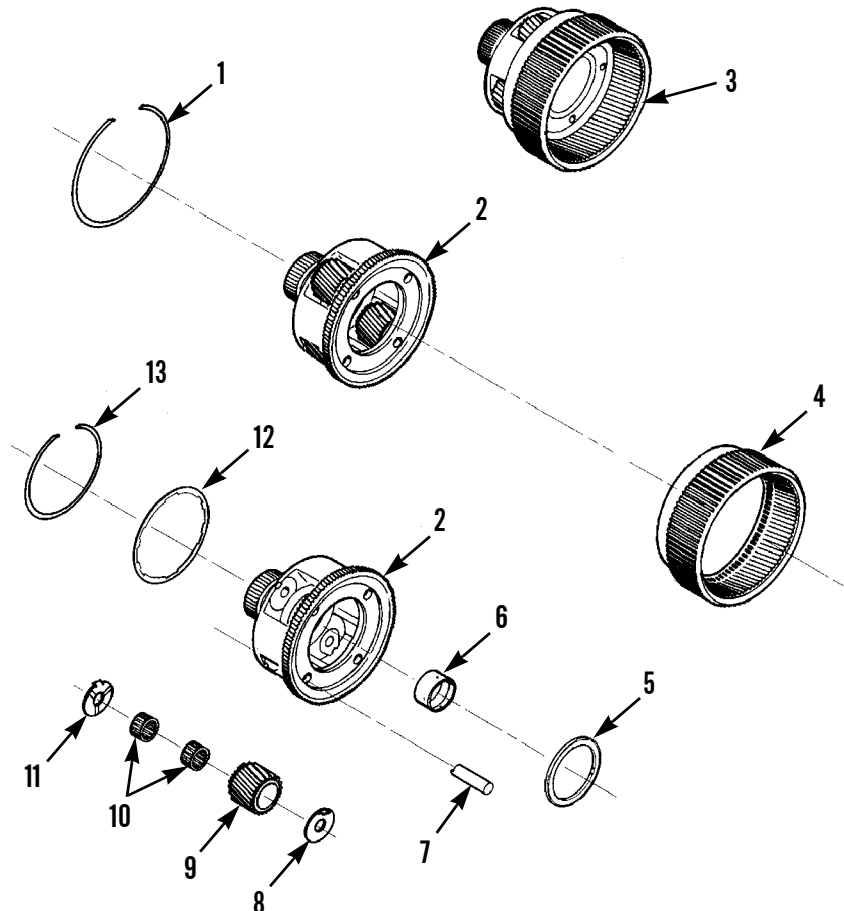

426-095

**MODULE OVERHAUL - CONTINUED****P2 Planetary Module Assembly**

1. If removed, replace bushing (6) into P2 planetary carrier (2) using a press and tool (J37036). Press new bushing flush to 0.016 in. (0.40 mm) below surface.
2. Install two bearing assemblies (10) into center of pinion gear (9). Install thrust washers (8 and 11) inside P2 planetary carrier (2), align thrust washer tangs with slots in planetary, and retain them with petrolatum. Slide pinion gear and bearing assemblies into side of P2 planetary carrier between thrust washers. Repeat procedure for remaining five pinion gears.
3. Install four pinion spindles (7) so that lower step is positioned for proper installation of indexing ring (12).
4. Install indexing ring (12) and retaining (13) to secure pinion gears in place.
5. Measure pinion end play. Pinion end play must not exceed 0.037 in. (0.94 mm). Check all four pinion gears.
6. Install P3 planetary ring gear (4) over P2 planetary carrier assembly (2).
7. Install retaining ring (1) into P3 planetary ring gear (4) so that P2 planetary carrier and P3 planetary ring gear are assembled.
8. Install thrust bearing (5) on planetary module (3).

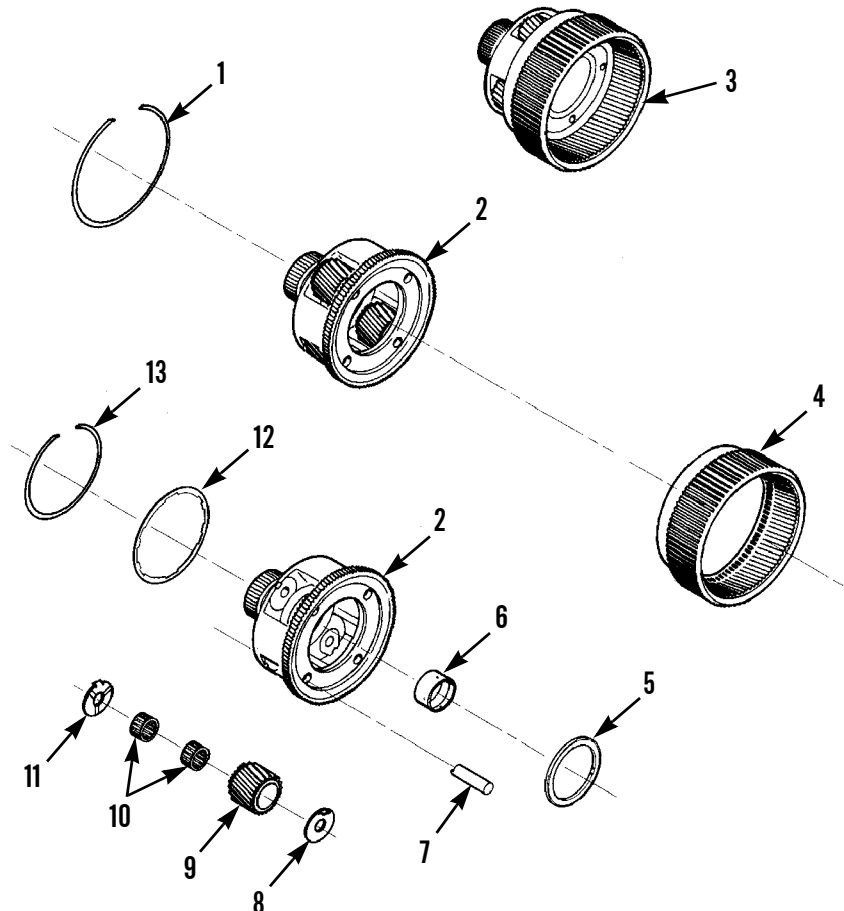

426-095



**MODULE OVERHAUL - CONTINUED**

**Rear Cover and P3 Planetary Module Disassembly**

1. Straighten tangs of locknut retainer (11) to allow removal of bearing retainer locknut (10). Remove bearing retainer locknut using tool (J37035). Remove locknut retainer.
2. Support rear cover assembly (3) so that P3 planetary carrier assembly (1) can be removed. Place tool (J37035-1) over output shaft splines and against threaded shoulder of P3 planetary carrier. Using a hydraulic press or a mallet, press on tool (J37035-1) to separate planetary carrier from rear cover.
3. Inspect rear cover cone and roller bearing (12). If worn or damaged, remove using tool (J3940).

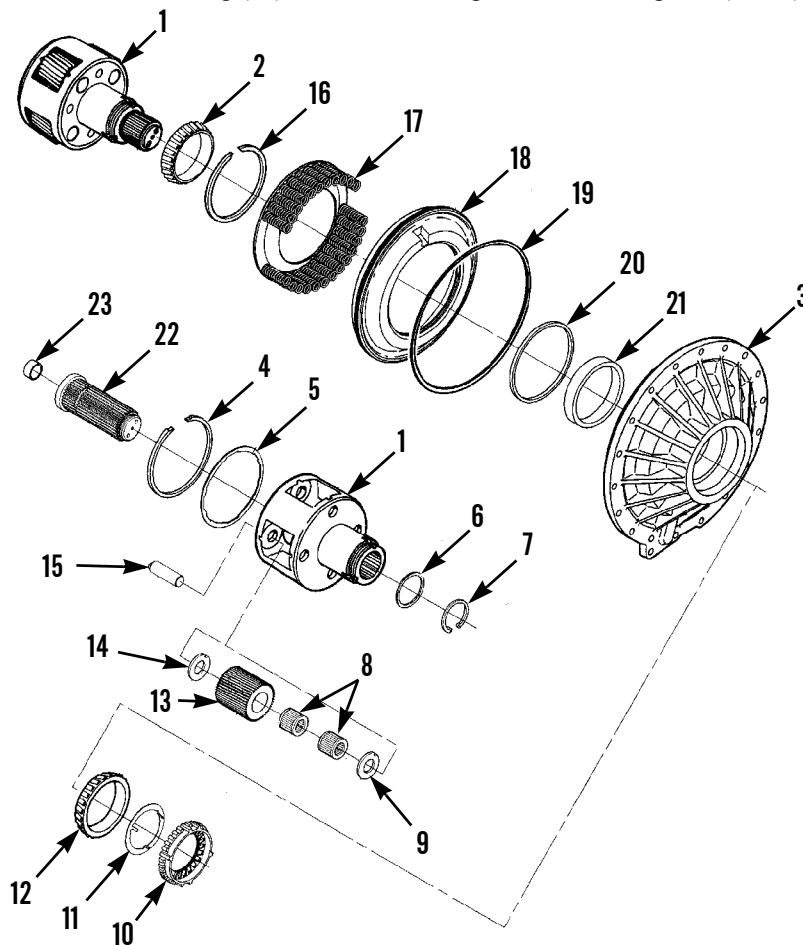

426-096



**WARNING**

Place P3 planetary carrier assembly on its side during disassembly to avoid possible hand injury.

4. Remove retaining ring (7) and thrust washer (6) from P3 planetary carrier assembly (1).
5. Inspect planetary carrier cone and roller bearing (2). If worn or damaged, remove.

**MODULE OVERHAUL - CONTINUED****Rear Cover and P3 Planetary Module Disassembly - Continued**

6. Remove retaining ring (4), indexing ring (5), and four pinion spindles (15) from P3 planetary carrier (1).
7. Remove pinion gear (13), thrust washers (9 and 14), and two bearing assemblies (8) from side of the P3 planetary carrier (1). Repeat procedures for remaining pinion gears. Measure thickness and step wear of thrust washers. Minimum thrust washer thickness allowed is 0.055 in. (1.40 mm). Maximum step wear allowed is 0.005 in. (0.12 mm).
8. Inspect and measure bushing (23) inside end of output shaft (22) for damage or wear. The maximum ID of bushing is 1.423 in. (36.14 mm).

**WARNING**

Rear cover spring and retainer assembly contains highly compressed springs. Be extremely careful during disassembly. Personal injury can occur if spring force is not controlled.

9. Remove C5 clutch piston (18) from rear cover (3) by compressing spring and retainer assembly (17), using tool (J37030-3) tool base, washer, bearing, handle, and piston compressor (J37030-2). Remove retaining ring (19) and slowly release spring force.
10. Remove outer seal ring (20) and inner seal ring (21) from C5 clutch piston (18).
11. Inspect bearing cup (16). If worn or damaged, remove using tool (J3940).

**Rear Cover and P3 Planetary Module Assembly**

1. If removed, install new bearing cup (16), using bearing tool (J37033) and drive sleeve tool (J37034).
2. Install inner seal ring (21) and outer seal ring (20) onto C5 clutch piston (18).
3. Align tang notch on rear of C5 clutch piston (18) with tang in rear cover (3), while installing C5 clutch piston into rear cover.
4. Install spring and retainer assembly (17) while aligning tab in spring and retainer assembly with notch in rear cover (3).

**WARNING**

Rear cover spring and retainer assembly contains highly compressed springs. Be extremely careful during assembly. Personal injury can occur if the spring force is not controlled.

5. Compress spring and retainer assembly (17) using (J37030-3) tool base, washer, bearing, handle, and piston spring compressor (J37030-2). Install retaining ring (19) and slowly release spring force.
6. If removed, install cone and roller bearing (2). Use driver sleeve tool (J37034) and press bearing against shoulder on P3 planetary carrier (1).
7. If removed, press bushing (23) inside end of output shaft (22) using installer tool (J37036) and a press.
8. Install output shaft (22), thrust washer (6), and retaining ring (7).
9. Install two bearing assemblies (8) into center of pinion gear (13). Install thrust washers (9 and 14) inside P3 planetary carrier (1), align thrust washer tangs with slots in planetary carrier, and retain them with petrolatum. Slide pinion gear and bearing assemblies into side of P3 planetary carrier between thrust washers. Repeat procedure for remaining three pinion gears.
10. Install four pinion spindles (15) so that lower step is positioned for proper installation of indexing ring (5).
11. Install indexing ring (5) and retaining ring (4).
12. Measure pinion end play. Pinion end play must not exceed 0.037 in. (0.94 mm). Check all four pinions.
13. Place P3 planetary carrier assembly (1) on work bench with output shaft up. Place rear cover (3) over output shaft.
14. If removed, install cone and roller bearing (12) into rear cover assembly (3) using drive sleeve tool J37034.
15. Install new locknut retainer (11).

**MODULE OVERHAUL - CONTINUED**

**Rear Cover and P3 Planetary Module Assembly - Continued**

**CAUTION**

Over-tightening bearing retainer locknut will damage cone and roller bearing assembly.

16. Install bearing retainer locknut (10). Tighten locknut to 55-65 lb-ft (74-88 Nm).

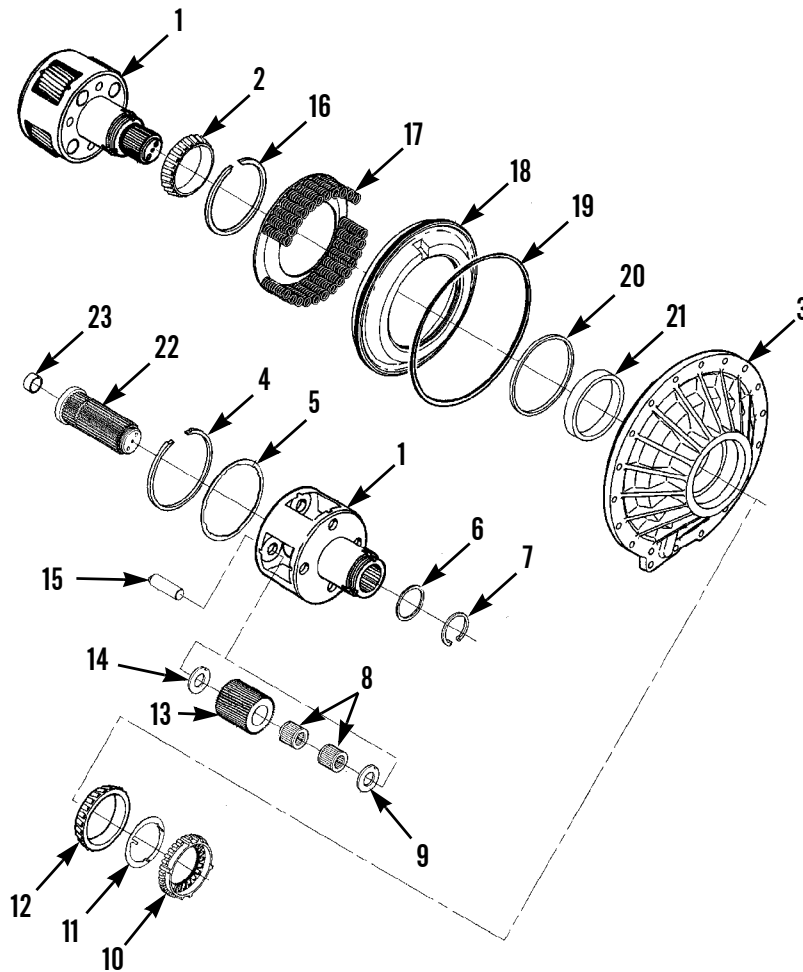

426-096

**MODULE OVERHAUL - CONTINUED****Rear Cover and P3 Planetary Module Assembly - Continued**

17. Position and support rear cover assembly (3) so that turning torque of P3 planetary carrier assembly can be checked after installation of bearing retainer locknut (10). Use tool (J37035-1) to check turning torque. Maximum turning torque is 27 lb-in. (3 Nm).

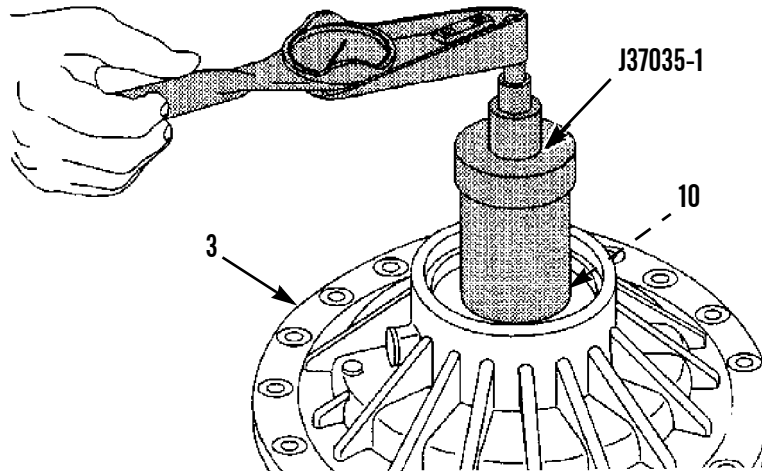

426-097



**MODULE OVERHAUL - CONTINUED****Control Valve Module Disassembly****NOTE**

The control valve module assembly springs and other parts can be mistakenly interchanged. Tag each part with its item name as it is removed and use valve tray set (J33163) to simplify correct valve reassembly.

1. Remove bolt (5) and two bolts (3) securing the suction filter housing (6).
2. Remove suction filter housing (6), filter (2), face seal (4), and gasket (1). Discard filter and gasket.
3. Remove four bolts (7) and wiring harness cover plate (8).
4. Tag and disconnect electrical connections.
5. Remove three bolts (10) and control harness assembly (9).
6. Remove three bolts (12) and rotating clutch solenoid body assembly (11).
7. Remove eight bolts (16) and stationary clutch solenoid assembly (15).
8. Remove two bolts (40) and main valve body assembly (87) (see page 0252 00-49 for illustration).

**NOTE**

Rotating clutch solenoid body disassembly procedures are steps 9 through 14.

9. Remove two bolts (14) and then remove C3 pressure switch (13) from rotating clutch solenoid body assembly (11).
10. Check resistance of C3 pressure switch. Maximum allowable resistance is 2 ohms when contacts are closed and must be 20,000 ohms minimum when contacts are open. Check pressure at which switch opens and closes. Both events must occur between 23-37 psi (104-255 kPa). Test block tool (J33884-25) is used to help make these checks.

**NOTE**

Solenoid retention pins (24) must be removed from bottom of solenoid body. Note grooved end of pin for positive retention.

11. Remove face seal (17), two solenoids (22), and one solenoid (23) by removing retention pins (24).
12. Remove three smaller O-rings (20) and three larger O-rings (21). Remove three solenoid regulator valves (19) and three springs (18).
13. Check resistance of each solenoid. Resistance must be 2-5 ohms.
14. Remove valve retention pin (25), stop (28), valve (26), and spring (27) from rotating clutch solenoid body (11).

**NOTE**

Stationary clutch solenoid body disassembly procedures are steps 15 through 20.

15. Remove two seals (38) from stationary clutch solenoid body (15).

**NOTE**

Solenoid retention pin (29) must be removed from bottom of solenoid body. Note grooved end of pin for positive retention.

16. Remove three solenoid retention pins (29) from bottom of solenoid body (15).
17. Remove three solenoids (33), six O-rings (34), three solenoid regulator valves (31), and three springs (30).
18. Check resistances of solenoids. Resistance must be 2-5 ohms.
19. Remove valve retention pin (32), stop (35), spring (36), and valve (37).

MODULE OVERHAUL - CONTINUED

Control Valve Module Disassembly

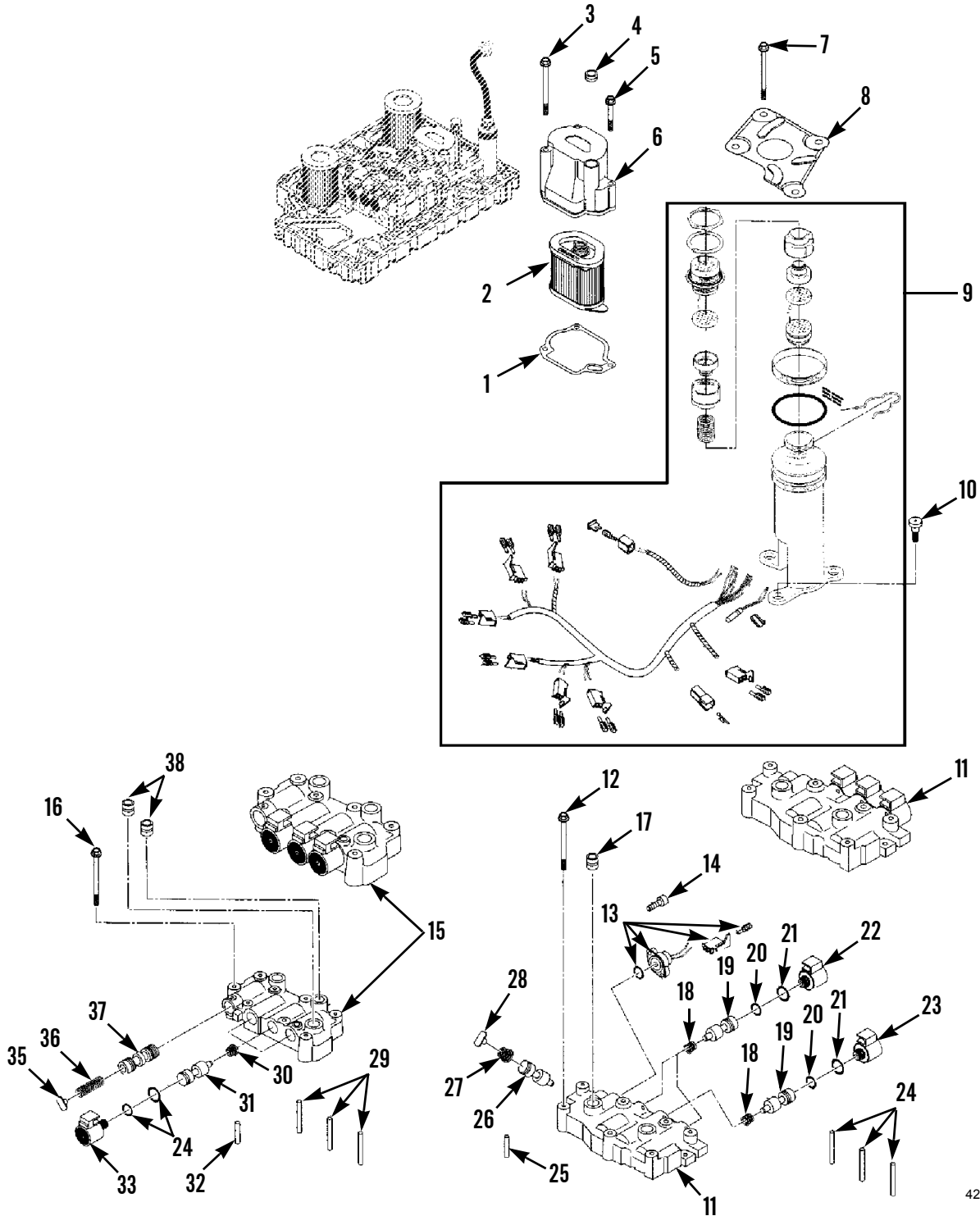

426-098

**MODULE OVERHAUL - CONTINUED****Control Valve Module Disassembly - Continued**

20. Remove solenoid separator plate (39).

**NOTE**

Main valve body disassembly procedures are steps 21 through 34.

21. If damaged, remove retention pin (74) from main valve body (87).

**NOTE**

Solenoid retention pins must be removed from bottom of valve body. Note grooved end of pin for positive retention.

22. Remove solenoid retention pin (49) from bottom of valve body (87).  
23. Remove solenoid (71), small O-ring (72), and large O-ring (73).  
24. Check resistances of solenoids. Resistance must be 2-5 ohms.  
25. Remove valve retention pin (43). Remove stop (52), spring (51), and converter flow valve (50).  
26. Remove valve retention pin (46), stop (53), spring (54), and lubrication regulator valve (55).

**WARNING**

Spring (57) is highly compressed. Be extremely careful during disassembly. Personal injury can occur if spring force is not controlled.

27. Install spring compressor tool (J35924). Compress spring (57), then remove valve retention pin (47). Carefully release spring force by rotating tool handle counterclockwise. Remove spring compressor tool.

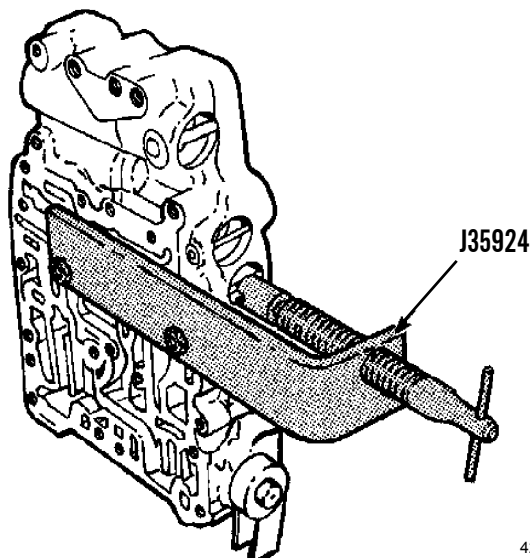

426-099



**MODULE OVERHAUL - CONTINUED**

**Control Valve Module Disassembly - Continued**

28. Remove stop (56), spring (57), and main regulator valve (58).
29. Push against stop (59) to compress spring (60) and remove valve retention pin (48). Slowly release pressure against stop and remove stop, spring, and main control valve (61).
30. Remove valve retention pin (45), stop (77), spring (76), and C2 latch valve (75).
31. Remove retention pin (41), stop (84), spring (85), and exhaust back pressure valve (86).
32. Remove retention pin (44), stop (78), spring (79), and C1 latching valve (80).
33. Remove retention pin (42), stop (81), spring (82), and converter regulator valve (83).

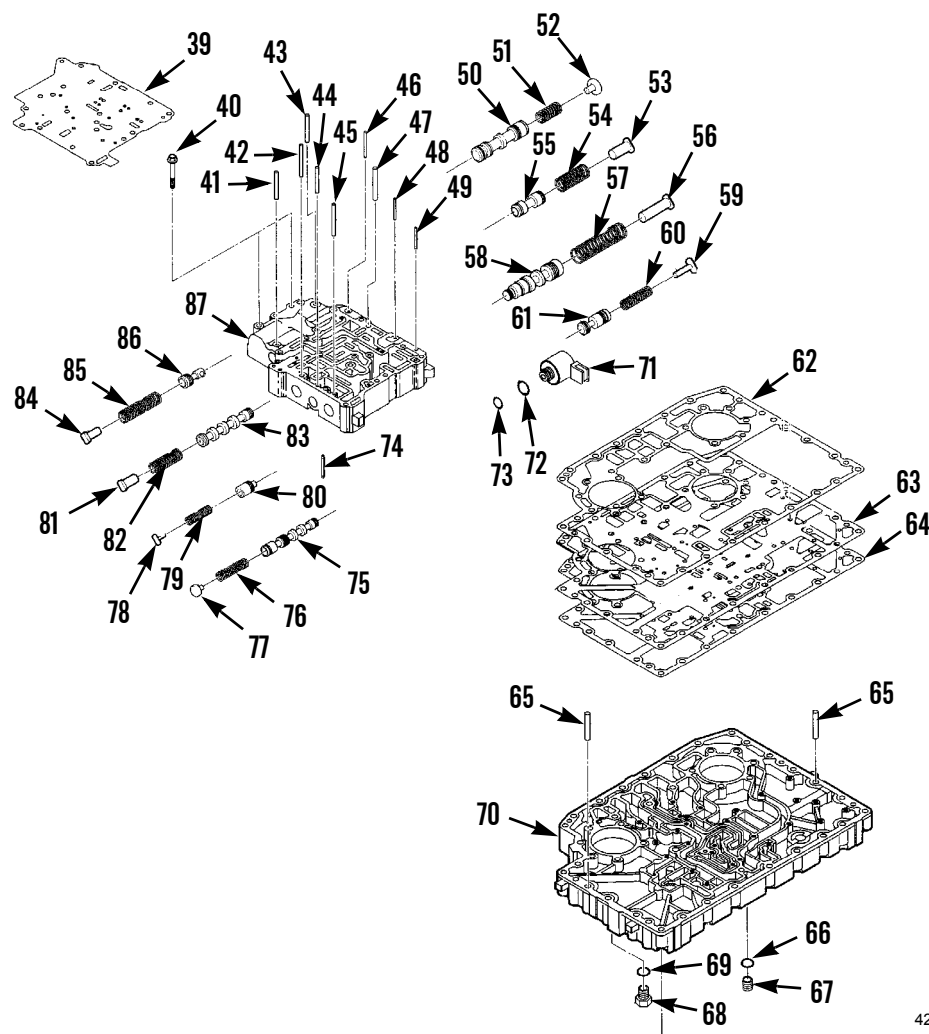

426-100

**MODULE OVERHAUL - CONTINUED****Control Valve Module Disassembly - Continued**

34. Remove gaskets (62 and 64) and separator plate (63) from channel plate assembly (70). Discard gaskets.

**NOTE**

Channel plate disassembly procedures are steps 35 through 37.

35. If damaged, remove two pins (65) from channel plate assembly (70).
36. Remove drain plug (67) and O-ring (66) from channel plate assembly (70). Discard O-ring.
37. Remove eight pressure tap plugs (68) and O-rings (69) from channel plate assembly (70). Discard O-ring.

**Control Valve Module Assembly****NOTE**

Channel plate assembly procedures are steps 1 through 4.

1. Install eight pressure tap plugs (68) and new O-rings (69). Tighten plugs to 7-10 lb-ft (10-13 Nm).
2. Install drain plug (67) and new O-ring (66). Tighten drain plug to 18-24 lb-ft (25-32 Nm).
3. If removed, install two pins (65) in channel plate assembly (70).
4. Install new gaskets (62 and 64) with separator plate (63) on channel plate assembly (70).

**NOTE**

Main valve body assembly procedures are steps 5 through 18.

5. Install converter regulator valve (83), spring (82), and stop (81).
6. Install valve retention pin (42) by pushing against stop (81) to compress spring (82).
7. Install C1 latching valve (80), spring (79), and stop (78). Install retention pin (44).
8. Install exhaust back pressure valve (86), spring (85), and stop (84). Install retention pin (41).
9. Install C2 latch valve (75), spring (76), and stop (77). Install retention pin (45).

**WARNING**

Spring (57) is highly compressed. Be extremely careful during assembly. Personal injury can occur if spring force is not controlled.

10. Install main control valve (61), spring (60), and stop (59). Install retention pin (48).
11. Install main regulator valve (58), spring (57), and stop (56).
12. Using spring compressor tool (J35924), compress spring (57) and install valve retention pin (47).
13. Carefully remove compressor tool.
14. Install lubrication regulator valve (55), spring (54), and stop (53). Install retention pin (46).
15. Install converter flow valve (50), spring (51), and stop (52). Install retention pin (43).
16. Install new small O-ring (72) and new large O-ring (73) on solenoid (71). Install solenoid.
17. Install solenoid retention pin (49), smooth side first, from bottom of main valve body assembly (87).
18. If removed, install retention pin (74) in main valve body assembly (87).

MODULE OVERHAUL - CONTINUED

Control Valve Module Assembly - Continued

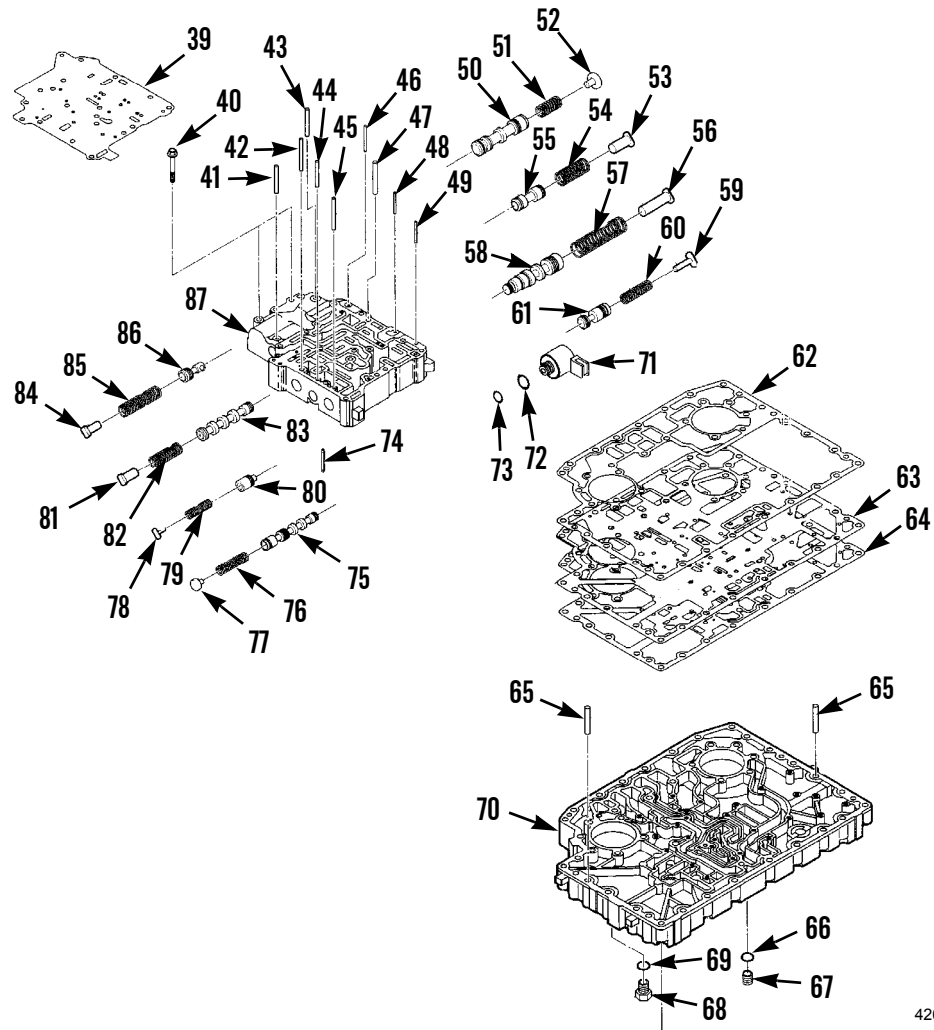

426-100

**MODULE OVERHAUL - CONTINUED****Control Valve Module Assembly - Continued****NOTE**

Stationary clutch solenoid body assembly procedures are steps 19 through 22.

19. Install valve (37), spring (36), and stop (35) in stationary clutch solenoid body (15). Install retention pin (32).
20. Install three springs (30), solenoid regulator valves (31), six new O-rings (34), and three solenoids (33).
21. As valve bores are filled, install three solenoid retention pins (29), smooth end first from bottom of solenoid body.
22. Install two new seals (38) in stationary clutch solenoid body (15).

**NOTE**

Rotating clutch solenoid body assembly procedures are steps 23 through 27.

23. Install spring (27), valve (26), and stop (28) in rotating clutch solenoid body (11) with retention pin (25).
24. Install three springs (18), three solenoid regulator valves (19), new smaller O-rings (20), and new larger O-rings (21).
25. Install face seal (17), two solenoids (22), and solenoid (23).
26. Install solenoid retention pins (24), smooth end first, from bottom of rotating clutch solenoid body (11).
27. Install pressure switch assembly (18) and two bolts (14). Tighten bolts to 44-71 lb-in. (5-8 Nm).

**NOTE**

Control valve module assembly procedures are steps 28 through 37.

28. Install main valve body assembly (87) and two bolts (40) (see page 0248 01-51 for illustration). Tighten bolts only finger tight.
29. Install control harness assembly (9) with three bolts (10). Tighten bolts to 18-26 lb-in. (2-3 Nm).
30. Install new gasket (1), new face seal (4) and new filter (2) in suction filter housing (6).
31. Install suction filter housing (6) with bolts (5) and two bolts (3). Tighten bolts only finger tight.
32. Install solenoid separator plate (39).
33. Install stationary clutch solenoid body assembly (15) with eight bolts (16). Tighten bolts only finger tight.
34. Install rotating clutch solenoid body (11) with three bolts (12). Tighten bolts only finger tight.
35. Install wiring harness cover plate (8) with four bolts (7). Tighten bolts only finger tight.
36. Connect all electrical connectors. Remove tags.
37. Evenly tighten cover plate bolts (7), suction filter bolts (3 and 5), valve body bolts (10, 12, and 16). Tighten all bolts to 7-10 lb-ft (10-13 Nm).

MODULE OVERHAUL - CONTINUED

Control Valve Module Assembly - Continued

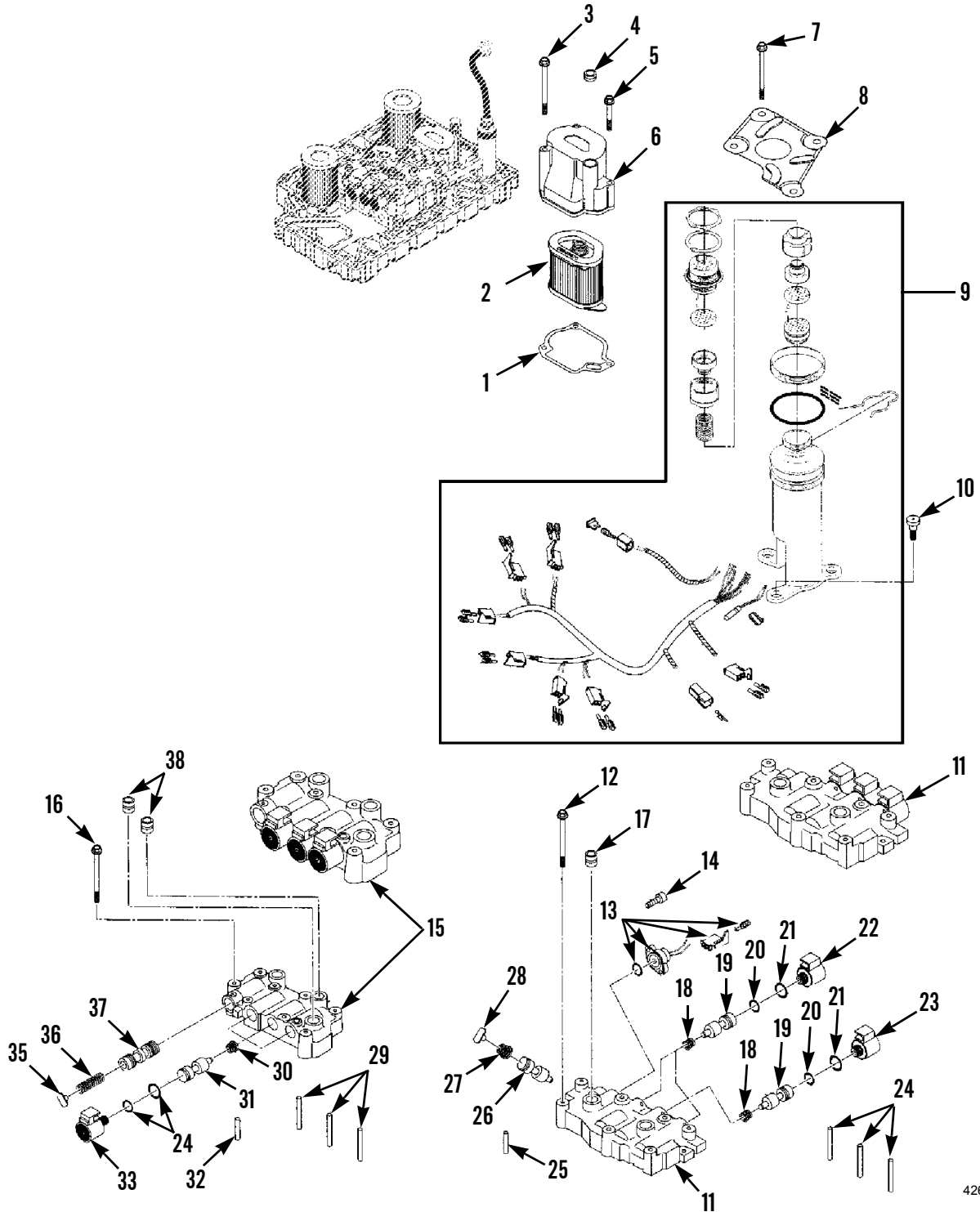

426-098

**ASSEMBLY****WARNING**

Use extreme caution when handling heavy parts. Provide adequate support and use assistance during procedure. Ensure that any lifting device used is in good condition and of suitable load capacity. Keep clear of heavy parts supported only by lifting device. Failure to follow this warning may result in death or injury to personnel.

**NOTE**

- Ensure all transmission components are cleaned and well lubricated before reassembling transmission assembly.
- Before beginning assembly, attach bracket (J41445) and holding fixture (J35926) to main transmission housing. Use a suitable hoist to mount fixture and housing on a repair stand.
- Ensure main housing is horizontal when installing C3/C4 clutch Module.

**Installation of C3/C4 Clutch Assembly**

1. Install C3/C4 clutch assembly (47) through input end of main housing (24), aligning bolt holes in clutch assembly with holes in main housing.
2. Install two bolts (48), 180 degrees from each other, to hold clutch in place.
3. Rotate transmission housing on stand and install remaining 12 bolts (48). Tighten bolts to 38-45 lb-ft (51-61 Nm).

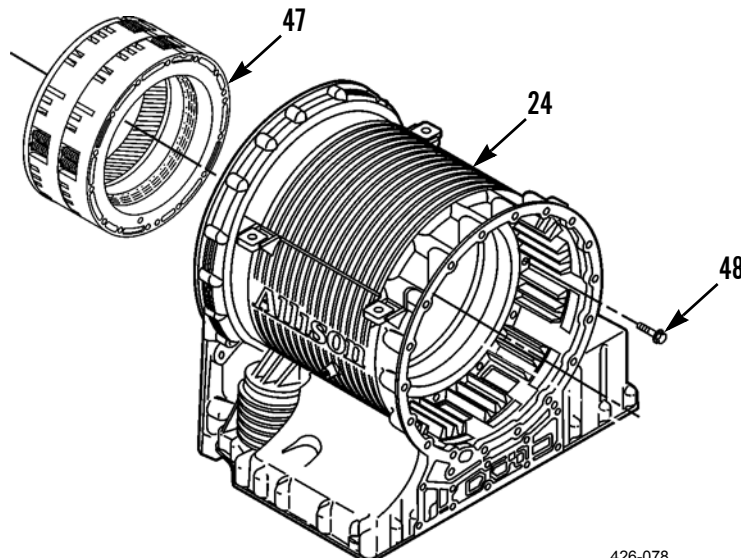

426-078

**ASSEMBLY - CONTINUED**

**Installation of Rotating Clutch Module and Front Support and Charging Pump Module**

1. Install an M16 eye bolt into turbine shaft (45). Using a suitable hoist, install rotating clutch module (46) into main housing (24). Remove eye bolt.
2. Lower front support and charging pump module (43) over top of turbine shaft (45).
3. Align bolt holes in front support and charging pump module (43) with threaded holes in main housing (24).
4. Install seven bolts (42) and seven bolts (44) in front support and charging pump module (43). Tighten bolts to 38-45 lb-ft (51-61 Nm).

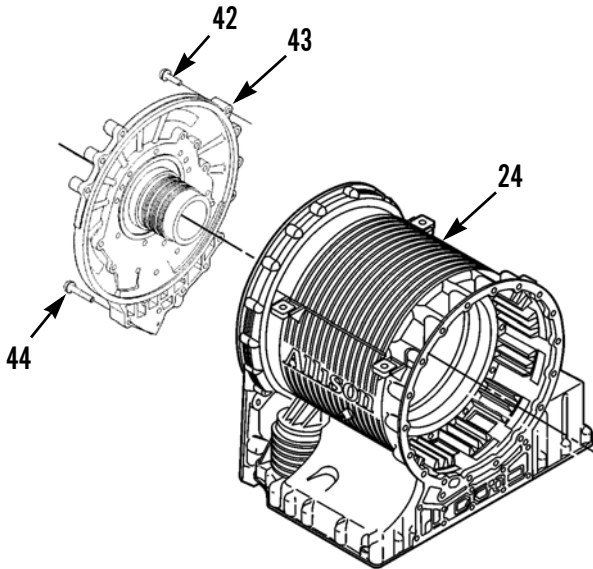

426-076

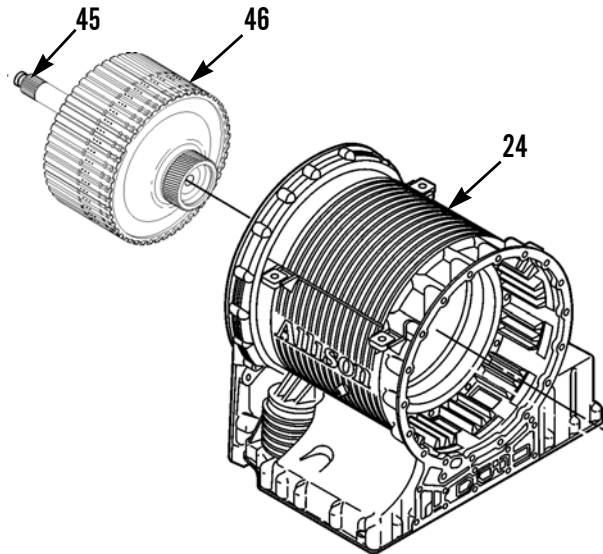

426-077

**Installation of P1/P2 Planetary Modules**

1. Install P1 planetary module (41), consisting of P1 carrier and P2 ring gear.
2. Mesh P1 pinion gears with P1 ring gear inside C3/C4 clutch assembly.
3. Install P2 planetary module (37), consisting of P2 carrier and P3 ring gear.
4. Mesh P2 pinion gears with P2 ring gear during installation.

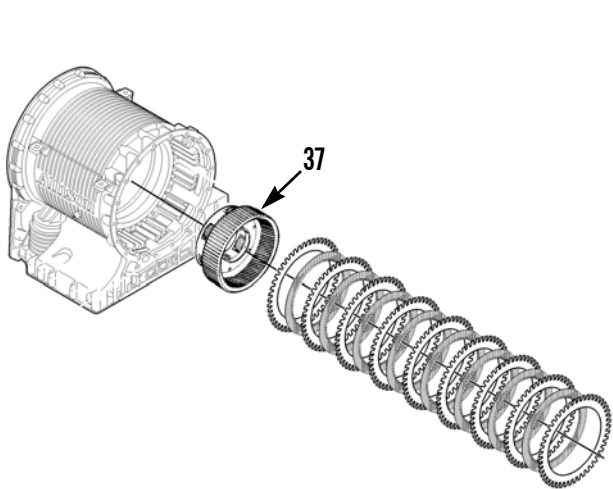

426-074

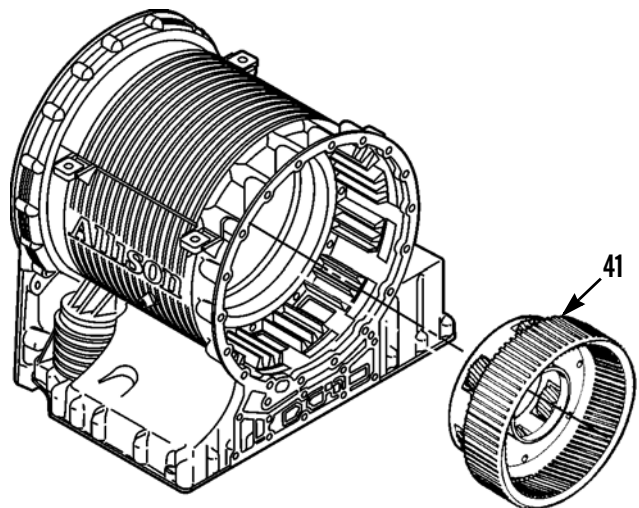

426-075

**ASSEMBLY - CONTINUED****Installation of C5 Clutch Pack**

1. Install C5 clutch pack (38) in main housing (24). Clutch pack consists of nine steel reaction plates (40) and eight friction plates (39), stacked alternately, starting with a steel reaction plate.
2. Stack all plates so that plate cone faces same direction. Steel plates mesh with main housing (24) and reaction plates mesh with P3 ring gear.

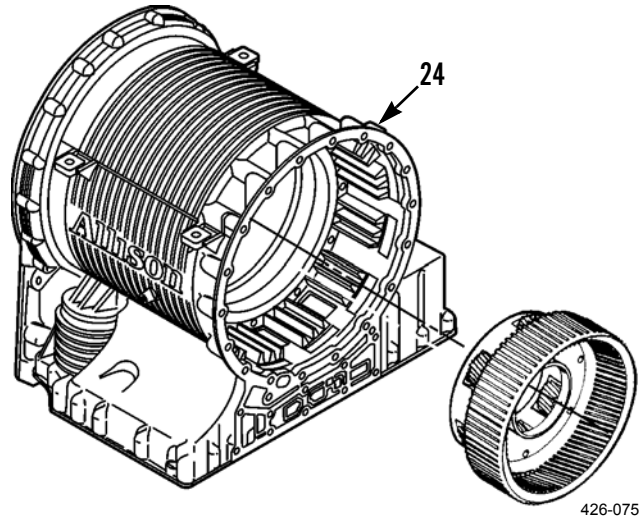
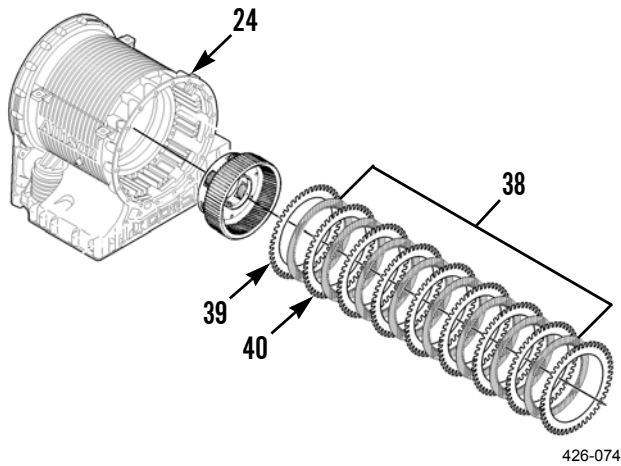



**ASSEMBLY - CONTINUED**

**Installation of Main Shaft Module and Selective Shim Measurement**

1. Install main shaft module assembly (34) in main housing (24), without selective shim (36) and thrust bearing (35).

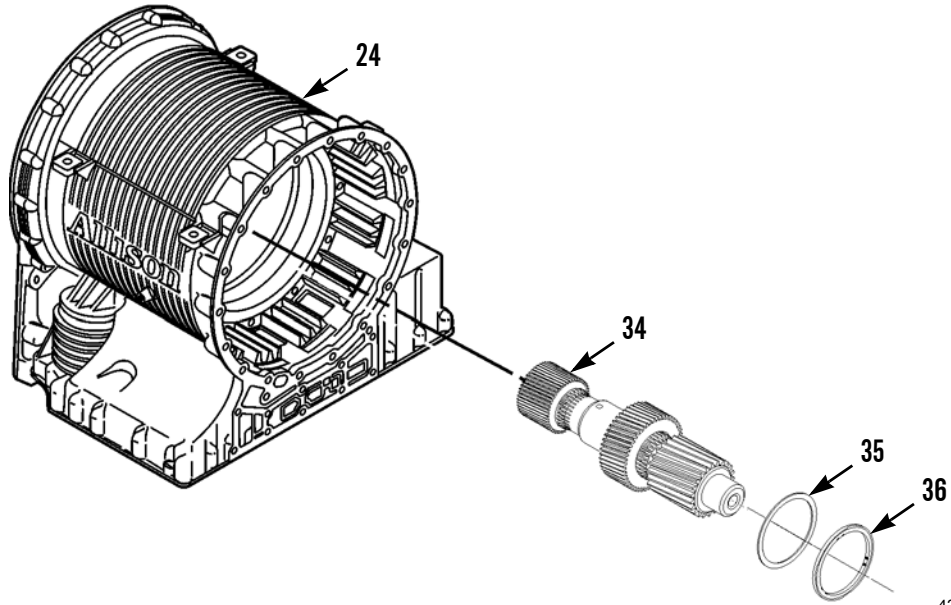

**ASSEMBLY - CONTINUED**

**Installation of Main Shaft Module and Selective Shim Measurement - Continued**

2. Place a straightedge across rear cover mounting surface.
3. Measure dimension "A", from top of straightedge to selective shim thrust surface on main shaft bearing spacer.
4. Measure dimension "B", thickness of straightedge. Subtract "B" from "A"; remainder is dimension "C".
5. Place rear cover, output end down (facing work bench). Install an uncompressed gasket on rear cover mounting surface and place a straightedge across P3 planetary carrier.
6. Measure dimension "D", from top of straightedge to rear cover mounting gasket.
7. Measure dimension "E", thickness of straightedge. Subtract dimension "E" from dimension "D"; remainder is dimension "F".
8. Dimension "G" is remainder of "C" minus "F" and determines thickness of selective shim (36).

**CAUTION**

Ensure thrust bearing is assembled with locating lip on either inner or outer thrust bearing race, not preventing race from contacting thrust surface of mating part. Failure to follow this caution leads to thrust bearing failure and incorrect shim selection to maintain proper part clearance.

9. Install proper thickness selective shim (36) and thrust bearing (35).

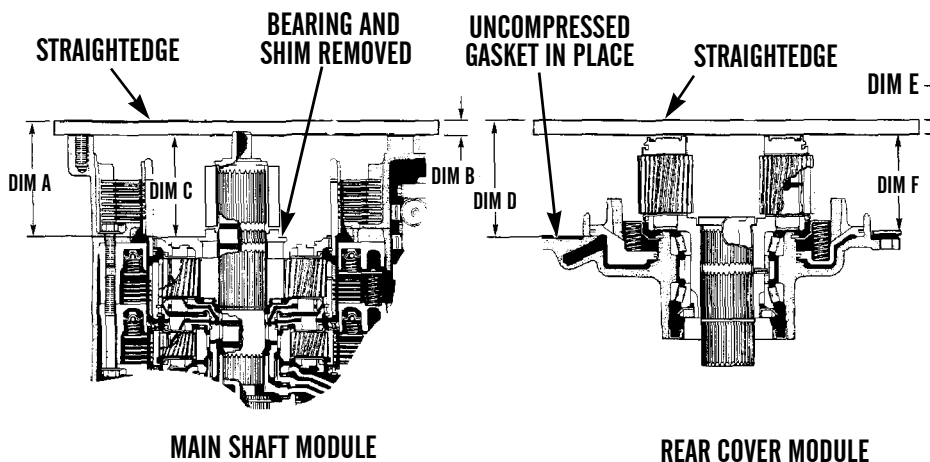

426-101

**PROCEDURE: FORMULA (C) - (F) = G**

DIM G	Use P/N	Shim ID
4.574-4.843 mm (0.180-0.190 in.)	29503218	1 Notch
4.844-5.113 mm (0.192-0.201 in.)	29503219	2 Notches
5.114-5.383 mm (0.202-0.212 in.)	29503220	3 Notches
5.384-5.653 mm (0.213-0.223 in.)	29503221	4 Notches
5.654-5.923 mm (0.224-0.233 in.)	29503222	5 Notches
5.924-6.193 mm (0.234-0.244 in.)	29503223	6 Notches
6.194-6.463 mm (0.245-0.254 in.)	29503224	7 Notches

**ASSEMBLY - CONTINUED****Installation of Rear Cover Module**

1. Install guide bolts to ease rear cover module (31) installation and keep gasket (30) in place.
2. Install new rear cover gasket (30) on main housing (24).
3. Place rear cover module (31) on main housing (24) using suitable hoist and sling as a lifting fixture.
4. Install 5 bolts (33).
5. Remove guide bolts and install remaining 14 bolts (33). Evenly tighten bolts to 74-88 lb-ft (100-120 Nm).

**NOTE**

Do not reuse locknut retainer locking tang once it has been bent. If all tangs have been used (bent), replace locknut retainer.

6. Retighten locknut retainer using tool (J37035-1) to 55-65 lb-ft (74-88 Nm).

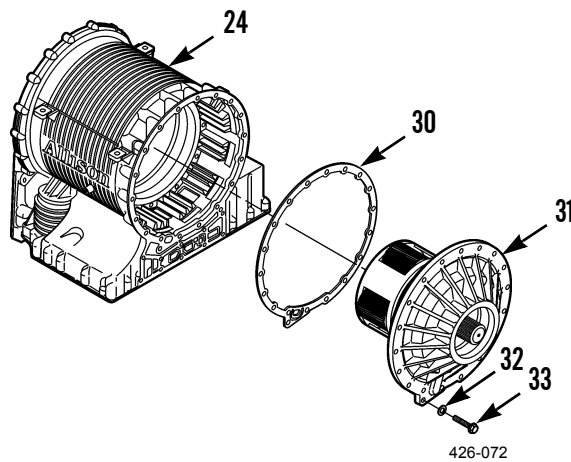

**ASSEMBLY - CONTINUED****Installation of Torque Converter Housing Module**

1. Install guide bolts to ease converter housing (22) installation and keep gasket (23) in place.
2. Position transmission with input end up. Install a new converter housing gasket (23) on main housing (24).
3. Lower torque converter housing (22) onto main housing (24) while rotating PTO drive gear to align gear teeth with charging pump.
4. Install seven bolts (25) into inside of torque converter housing (22). Use of mechanical fingers or similar tool may be required to insert and start bolts.
5. Remove guide bolts and install remaining 18 bolts (25). Tighten all bolts to 55-65 lb-ft (74-88 Nm)

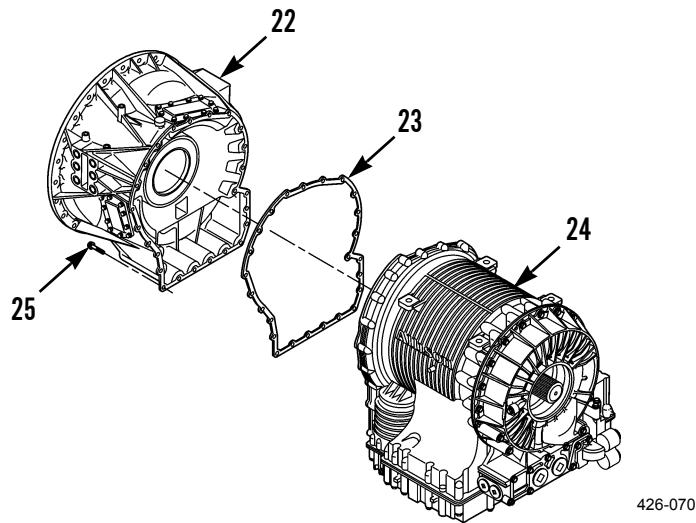

**ASSEMBLY - CONTINUED****Installation of Torque Converter Module and Selective Shim Measurement****NOTE**

- Torque converter is installed over turbine shaft which rotates inside stator shaft or ground sleeve. Splines on ground sleeve engage converter stator. Splines on turbine shaft engage converter turbine. End of turbine shaft is threaded and machined to accept converter retaining bolt and lockup seal ring.
  - Splines of ground sleeve and turbine shaft must engage with their respective splines in torque converter module. Tangs on converter-pump hub must engage charging pump's drive gear or PTO oil pump drive gear hub.
1. Using a suitable hoist and sling, install torque converter module (18) into torque converter housing (19).
  2. Ensure that torque converter module (18) is properly seated. Rotate PTO gear to engage pump hub with charging pump.
  3. Install converter end play gage tool (J38548) and tighten attaching bolts to 20-25 lb-ft (27-34 Nm). Install two bolts (20) into flexplate adapter (21). Use two bars at an angle to prevent turbine shaft rotation.
  4. Measure from top of end play gage tool (J38548) to face of turbine shaft and record it as dimension "B". Subtract dimension "B" from dimension "A" to determine dimension "C" (Note dimension "A" is height of tool J38548, 3.937 inch (100.00 mm).
  5. Use dimension "C" and Table 1, Torque Converter Selective Shims, located at the end of this work package, to determine proper selective shim part number.
  6. Remove torque converter end play tool (J37548).

**NOTE**

Turbine and turbine shaft may rotate while attempting to tighten retaining bolt. Prevent turbine shaft from turning in same manner as in step number 3.

7. Install threaded plug (14) and new O-ring (15). Tighten plug to 37-44 lb-ft (51-61 Nm).
8. Install torque converter shipping bracket. Tighten shipping bracket mounting bolts to 38-45 lb-ft (51-61 Nm).

ASSEMBLY - CONTINUED

Installation of Torque Converter Module and Selective Shim Measurement-Continued

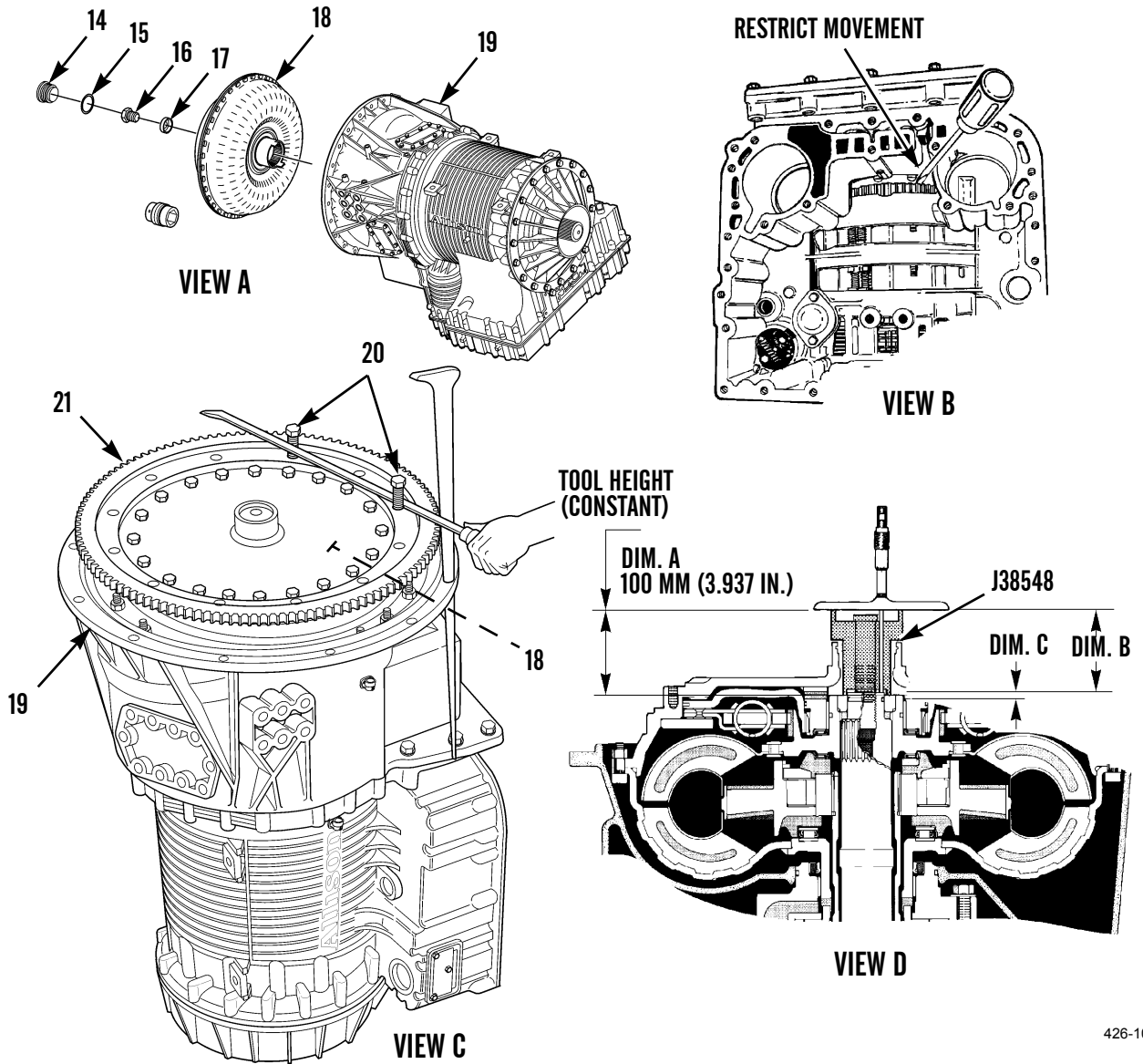

426-102

**ASSEMBLY - CONTINUED**

**Installation of Control Valve Module**

1. Position transmission in a vertical position, torque converter up.
2. Install two guide pins in two main housing bolt holes. Install new control module gasket (26) over guide pins.



Use extreme caution when handling heavy parts. Provide adequate support and use assistance during procedure. Ensure that any lifting device used is in good condition and of suitable load capacity. Keep clear of heavy parts supported only by lifting device. Failure to follow this warning may result in death or injury to personnel.

3. Guide control module (27) onto main housing (24).
4. Align control module (27) bolt holes with guide pins.
5. Install 41 bolts (28 and 29) securing control module (27) to main housing (24).
6. Remove two guide pins and install remaining two bolts (28 and 29). Tighten bolts to 38-45 lb-ft (51-61 Nm).

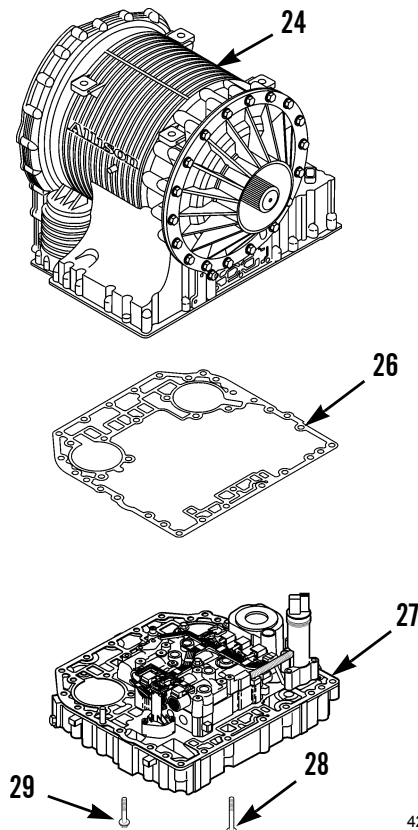

426-071

**ASSEMBLY - CONTINUED**

**Installation of Filters and Breather**

1. Install 12 bolts (6), two filter covers (5), new O-rings (4), new square cut seals (3), and new filters (2) in control module.
2. Install transmission breather vent (1) in torque converter housing.

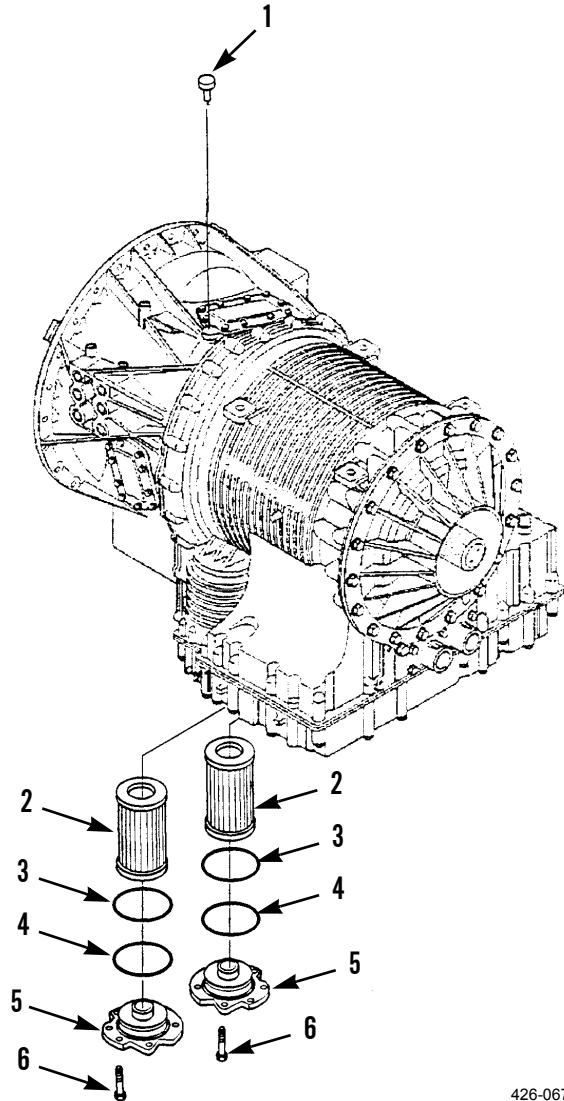

426-067



**ASSEMBLY - CONTINUED**

**Installation of Output Shaft and Oil Seal**

1. Install new oil seal (7) in rear cover.
2. Install slinger (8) using tool J46150.
3. Install output shaft yoke (9), new O-rings (10 and 11), retainer plug (12) and bolt (13). Tighten bolt to 38-45 lb-ft (51-61 Nm).

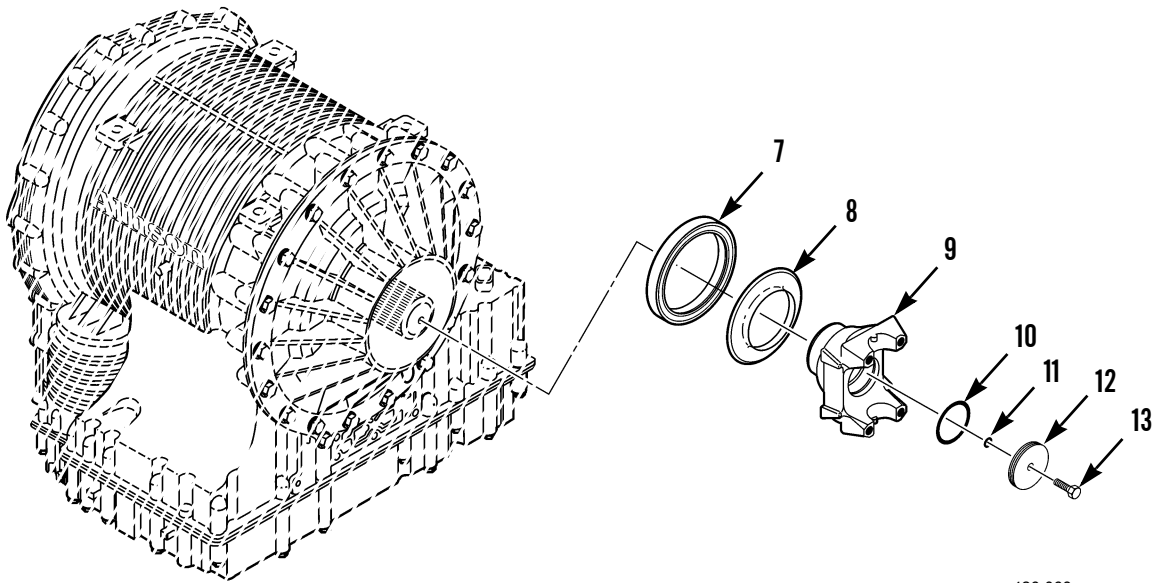

426-068

4. Install engine, turbine, and output speed sensors (WP 0112 00).

**TABULATED DATA**

**Table 1. Torque Converter Selective Shims.**

Dimension C	Use P/N	Shim Thickness (Ref.)	ID No.
0.4129-0.6598 mm (0.0163-0.0259 in.)	29505688	4.000 mm (0.157 in.)	0
0.6597-0.8378 mm (0.0260-0.0329 in.)	29505681	4.203 mm (0.165 in.)	1
0.8379-1.0158 mm (0.0330-0.0399 in.)	29505682	4.381 mm (0.172 in.)	2
1.0159-1.1938 mm (0.0400-0.0469 in.)	29505683	4.559 mm (0.179 in.)	3
1.1939-1.3708 mm (0.0470-0.0539 in.)	29505684	4.736 mm (0.186 in.)	4
1.3709-1.5488 mm (0.0540-0.0609 in.)	29505685	4.914 mm (0.193 in.)	5
1.5489-1.7268 mm (0.0610-0.0679 in.)	29505686	5.092 mm (0.200 in.)	6
1.7269-1.9048 mm (0.0680-0.0749 in.)	29507793	5.270 mm (0.207 in.)	7
1.9049-1.9733 mm (0.0750-0.0776 in.)	29507794	5.448 mm (0.214 in.)	8

**TABULATED DATA - CONTINUED**

**Table 2. Wear Limits Data.**

Description	Wear Limit	
	mm	inches
<b>TORQUE CONVERTER MODULE</b>		
Converter Cover Bushing, Maximum ID	66.91	2.634
Lockup Piston Assembly, Minimum Thickness	6.53	0.257
Damper Assembly Plate, Maximum Distortion	0.51	0.020
Damper Assembly Plate, Minimum Thickness	8.51	0.335
Turbine-to-damper, Maximum Spline Wear	0.38	0.015
Backplate, Maximum Distortion	0.15	0.006
Backplate, Minimum Wear Surface Thickness	11.79	0.464
Turbine Hub, Minimum OD	66.69	2.626
Turbine Hub Sealring, Maximum ID	61.77	2.432
Stator Thrust Plate, Minimum Thickness	9.45	0.372
Converter Pump Hub, Minimum OD	88.99	3.504
<b>TORQUE CONVERTER HOUSING MODULE - PTO EQUIPPED</b>		
Bearing Retainer Bushing, Maximum ID	89.19	3.511
Oil Pump Drive Hub Seal, Minimum End Gap	1.18	0.046
Oil Pump Drive Hub Seal, Maximum End Gap	1.66	0.065
Oil Pump Drive Hub, Maximum Tank Wear	0.31	0.012
<b>FRONT SUPPORT AND CHARGING PUMP MODULE</b>		
Pump Housing Bushing, Maximum ID	89.19	3.511
Pump Housing Gear, Maximum Cavity Depth	19.04	0.750
Pump Housing Gear, Maximum Cavity Diameter	150.25	5.915
Driven Gear-to-pump Housing, Maximum Diametric Clearance	0.30	0.012
Gear-To-Plate, Maximum Side Clearance	0.10	0.004
Gear Set, Maximum Gear Tooth Tip Clearance	0.15	0.006
Pump Gear Bushing, Maximum ID	66.93	2.635
Ground Sleeve, Minimum OD in Bushing Area	66.67	2.625
Spline OD, Maximum Total Runout	0.13	0.005
Front Support, Minimum OD	119.81	4.717
Front Support Seal, Minimum End Gap	1.00	0.040
Front Support Seal, Maximum End Gap	1.44	0.057

**TABULATED DATA - CONTINUED**

**Table 2. Wear Limits Data - Continued.**

Description	Wear Limit	
	mm	inches
<b>ROTATING CLUTCH MODULE</b>		
Turbine Shaft Bushing, Maximum ID	36.14	1.423
Turbine Seal, Minimum End Gap	0.65	0.026
Turbine Seal, Maximum End Gap	1.01	0.040
Drum Spline, Maximum Wear	0.38	0.015
Rotating Clutch Hub Bushing, Maximum ID	120.27	4.735
C1 Clutch Apply Plate, Minimum Thickness	5.90	0.232
C1 Clutch Apply Plate or C2 Backplate, Maximum Distortion	0.15	0.006
C1, C2 Friction Plate, Maximum Cone	0.25	0.010
C1, C2 Friction Plate, Minimum Thickness	2.92	0.115
C1, C2 Friction Plate, Minimum Oil Groove Depth	0.20	0.008
C1, C2 Reaction Steel Plate, Maximum Cone	0.25	0.010
C1, C2 Reaction Steel Plate, Minimum Thickness	2.41	0.095
C1 Clutch Backplate, Minimum Thickness @ ID	9.90	0.390
C1, C2 Drive Hub, Maximum Spline Wear	0.38	0.015
C2 Backplate, Minimum Thickness	7.90	0.311
<b>MAIN HOUSING MODULE</b>		
Backplate, Maximum Step Wear	0.13	0.005
Backplate, Maximum Distortion	0.15	0.006
P1 Ring Thrust Plate, Minimum Thickness at Wear Point	2.82	0.111
P1 Ring Gear Spline, Maximum Wear	0.38	0.015
C3, C4, C5 Friction Plate, Maximum Cone	0.25	0.010
C3, C4, C5 Friction Plate, Minimum Thickness	3.485	0.137
C3, C4 Friction Plate, Maximum Friction Material Erosion Around Lubrication Slots	4.00	0.157
C3, C4, C5 Reaction (Steel) Plate, Maximum Cone	0.25	0.010
C3, C4, C5 Reaction (Steel) Plate, Minimum Thickness	3.25	0.128
C3, C4 Piston Return Plate, Minimum Thickness	4.91	0.193
C3, C4, Clutch Housings, Maximum Spline Wear	1.15	0.045
Main Housing, Maximum Spline Wear	1.15	0.045
<b>MAIN SHAFT MODULE - WIDE RATIO AND CLOSE RATIO</b>		
Main Shaft Bearing Journal, Minimum OD	52.98	2.086
Main Shaft Pilots (Both Ends), Minimum OD	35.92	1.414
Main Shaft Splines, Maximum Wear	0.38	0.015

## TABULATED DATA - CONTINUED

Table 2. Wear Limits Data - Continued.

Description	Wear Limit	
	mm	inches
<b>P1 PLANETARY MODULE</b>		
P1 Planetary Carrier Assembly, Maximum Pinion End Play	0.94	0.037
P1 Carrier Bushing, Maximum ID	89.32	3.517
P1 Pinion Thrust Washer, Minimum Thickness	1.40	0.055
P1 Pinion Thrust Washer, Maximum Step Wear	0.12	0.005
P2 Ring Gear Spline, Maximum Wear	0.38	0.015
<b>P2 PLANETARY MODULE</b>		
P2 Planetary Carrier Assembly, Maximum Pinion End Play	0.94	0.037
P2 Carrier Bushing, Maximum ID	53.23	2.096
P2 Pinion Thrust Washer, Minimum Thickness	1.40	0.055
P2 Pinion Thrust Washer, Maximum Step Wear	0.12	0.005
P3 Ring Gear Spline, Maximum Wear	0.38	0.015
<b>REAR COVER AND P3 MODULE</b>		
P3 Planetary Carrier Assembly, Maximum End Play	0.94	0.037
Output Shaft Bushing, Maximum ID	36.14	1.423
Output Shaft, Maximum Spline Wear	0.38	0.015
P3 Pinion Thrust Washer, Minimum Thickness	1.40	0.055
P3 Pinion Thrust Washer, Maximum Step Wear	0.12	0.005
<b>OUTPUT FLANGE AND YOKE</b>		
Journal Seal, Maximum OD	85.0	3.346

Table 3. Wear Limits and Spring Data.

Spring	Part Number	Color Code	No. Of Coils	Wire Dia mm (in.)	Spring Od mm (in.)	Approx Free Length mm (in.)	Length Under Load	
							mm (in)	n (lb)
Stator	29501300	No Code	N/A	N/A	N/A	17.8 (0.70)	5.7 (0.224)	0.9 (0.2)
Main Relief	29507709	No Code	10	3.25 (0.128)	17.96 (0.707)	52.4 (2.06)	40.7 (1.60)	474 (106.5)
C2 Return	29505719	No Code	11.5*	2.04* (0.080)	19.06* (0.750)	70.76* (2.786)	28.2 (1.110)	5185** (1165.6)
C1 Return	29509453	No Code	12*	2.10* (0.083)	16.0* (0.630)	57.53* (2.265)	34.8 (1.37)	4649** (1045.4)
C1 Return	29537301	No Code	11.8*	2.17* (0.085)	16.8* (0.661)	52.89* (2.082)	34.5* (1.358)	4893** (1100.0)
C3 Return	29542504	Pink	13.8	2.10* (0.083)	15.0* (0.590)	55.55* (2.187)	39.25 (1.545)	143.5** (32.3)
C3 Retainer	29507882	No Code	4*	2.36* (0.093)	12.62* (0.497)	11.2* (0.44)	9.3 (0.37)	16408** (3689)
C3 Retainer	29515628	No Code	4*	2.36* (0.093)	12.62* (0.497)	11.1* (0.44)	10.40 (0.41)	15403** (3463)
C4 Return	29506206	No Code	13*	2.10* (0.083)	15.0* (0.590)	52.3* (2.06)	35.4 (1.39)	274.4** (6169)
C4 Retainer	29507882	No Code	4*	2.36* (0.093)	12.62* (0.497)	11.2* (0.44)	9.3 (0.37)	16408** (3689)
C4 Retainer	29515628	No Code	4*	2.36* (0.093)	12.62* (0.497)	11.1* (0.44)	10.40 (0.41)	15403** (3463)
Retarder	6880775	Yellow/ Red Stripe	12	1.93 (0.076)	16.61 (0.654)	53.8 (2.12)	35.30 (1.390)	81.4 (18.30)
Retarder Control	29510495	Silver	7.5	1.40 (0.055)	15.1 (0.594)	3.08 (1.212)	18.0 (0.71)	33 (7.42)
Retarder Control	29512792	Lt. Green (on end)	7.5	1.40 (0.055)	15.09 (0.594)	33.69 (1.326)	18.0 (0.71)	40 (9.0)
Retarder Control	29510494	Orange	7	1.60 (0.063)	15.50 (0.610)	27.8 (1.09)	18.0 (0.71)	44 (9.9)

\* Individual springs

\*\* For complete spring assembly

Change 1

Table 3. Wear Limits and Spring Data - Continued.

Spring	Part Number	Color Code	No Of Coils	Wire Dia mm (in)	Spring Od mm (in)	Approx. Free Length mm (in)	Length Under Load	
							mm (in)	n (lb)
Retarder Exh. Back	23049391	No Code	17	0.61 (0.024)	7.80 (0.307)	29.2 (1.14)	18.2 (0.72)	2 (0.5)
C5 Return	29503036	No Code	12*	2.10* (0.083)	17.00* (0.669)	57.3* (2.26)	37.6 (1.48)	3086** (693.8)
Solenoid Regulator	29502195	No Code	4	0.67 (0.026)	11.05 (0.440)	6.5 (0.26)	3.45 (0.14)	3 (0.7)
Accumulator Relay	29507455	Silver	12.8	1.28 (0.050)	11.68 (0.460)	43.6 (1.72)	20.0 (0.79)	47 (10.6)
Overdrive	23049332	Orange	12	0.76 (0.030)	7.75 (0.305)	26.6 (1.05)	12.5 (0.49)	12.0 (2.7)
Solenoid Regulator	29502195	No Code	4	0.67 (0.026)	11.05 (0.440)	6.5 (0.26)	3.45 (0.14)	3 (0.7)
Lockup	23049326	Yellow	10	1.37 (0.054)	14.1 (0.555)	42.1 (1.66)	17.0 (0.67)	49 (11.0)
Lube Regulator	23049327	Red	13	1.22 (0.048)	11.1 (0.437)	46.3 (1.82)	3.5 (0.93)	47 (10.6)
Main Regulator	29500963	Lt. Blue	15	2.87 (0.113)	22.00 (0.866)	98.5 (3.88)	54.6 (2.15)	305 (68.6)
Control Main	23049325	Orange	10	1.83 (0.072)	14.8 (0.583)	44.6 (1.76)	24.0 (0.95)	131 (29.5)
C2 Latch	29501071	Lt. Green	11	1.32 (0.052)	11.43 (0.450)	41.3 (1.63)	19.0 (0.75)	71.0 (16.0)
Exh. Back	23049391	No Code	17	0.61 (0.024)	7.80 (0.307)	29.2 (1.14)	18.2 (0.72)	2 (0.5)
C1 Latch	6885065	Blue	12	1.37 (0.054)	16.26 (0.640)	46.2 (1.82)	29.2 (1.15)	18 (4.0)
Converter Regulator	29507456	Pink	10.2	1.53 (0.060)	11.00 (0.433)	30.3 (1.19)	22.8 (0.90)	54 (12.1)

\* Individual springs

\*\* For complete spring assembly

END OF WORK PACKAGE

0248 01-70

TM 9-2320-303-24-2

**THIS WORK PACKAGE COVERS**

Removal, Installation

**INITIAL SETUP**

**Maintenance Level**

Direct Support

**Tools and Special Tools**

Tool kit, general mechanic's (Item 102, WP 0313 00)

Jack, hydraulic (Item 52, WP 0313 00)

Wrench, torque, 50-250 lb-ft (Item 111, WP 0313 00)

Wrench, torque, 100-600 lb-ft (Item 112, WP 0313 00)

Wrench set, socket, 3/4 in drive (Item 113, WP 0313 00)

**Materials/Parts**

Compound, antiseize (Item 11, WP 0312 00)

Compound, sealing (Item 16, WP 0312 00)

Pin, cotter (P/N MS24665-359) (3)

**Personnel Required**

Two

**Equipment Condition**

Front brake spider and brake chamber bracket removed (WP 0123 00)

ABS sensor removed (WP 0091 00)

**REMOVAL**

**NOTE**

Procedure is the same for both sides except where noted.

1. On left side, remove cotter pin (3) and castellated nut (2) and set drag link (1) aside. Discard cotter pin.
2. Remove two cotter pins (5), two castellated nuts (6), and tie rod (4). Discard cotter pins.

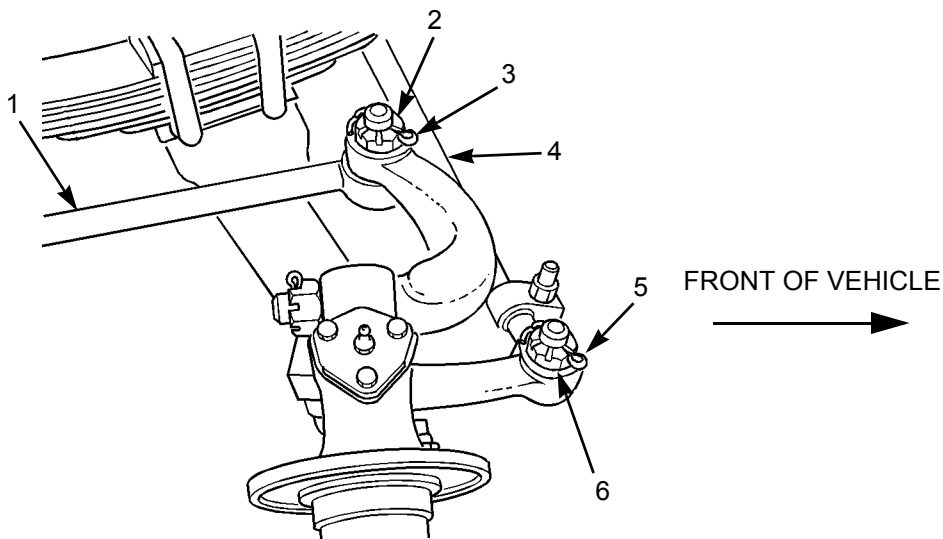

402-631

**REMOVAL - CONTINUED**



Front axle weighs 1,060 lb (481 kg). Support front axle with suitable floor jack during removal to prevent possible injury to personnel.

**NOTE**

Make sure front of vehicle is blocked up enough to allow removal of axle.

3. Position suitable floor jack under center of axle (12) and secure axle to floor jack.

**NOTE**

Note position of axle stops during removal to aid in installation.

4. Remove eight nuts (10), eight washers (11), four U-bolts (8), and two axle stops (7).
5. Lower axle (12) and remove from vehicle.
6. Remove spacer (14) and shim (9).
7. Remove pin (13) from spacer (14).
8. Using lifting device, remove axle (12) from floor jack.

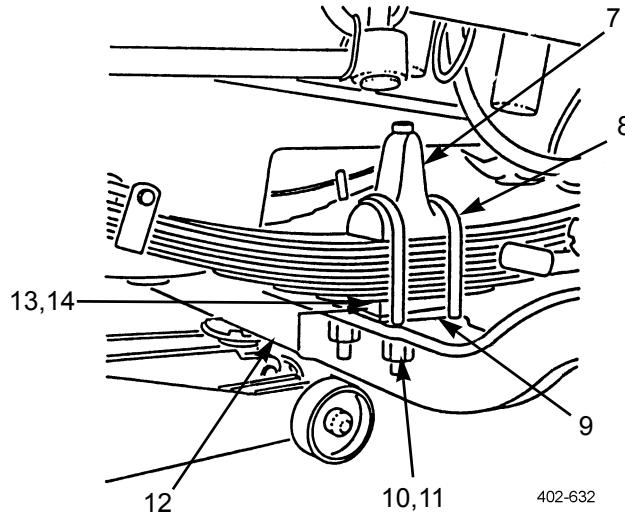

**INSTALLATION**



Front axle weighs 1,060 lb (481 kg). Support front axle with suitable floor jack during installation to prevent possible injury to personnel.



**INSTALLATION - CONTINUED****NOTE**

Procedure is the same for both sides except where noted.

1. With axle (12) installed and secured on suitable floor jack, position axle under vehicle.
2. Coat bottom of shim (9) with sealing compound and install shim on axle (12) with wide end of shim toward rear of vehicle.
3. Install pin (13) in spacer (14).
4. Coat top of spacer (14) with sealing compound and install spacer on top of shim (9).
5. Install axle (12).
6. Coat bottom and U-bolt saddles of two axle stops (7) with antiseize compound.
7. Install two axle stops (7), four U-bolts (8), eight washers (11), and eight nuts (10) on axle (12). Tighten nuts to 380-460 lb-ft (515-624 Nm).
8. Remove floor jack from under vehicle.
9. Install tie rod (4) and two castellated nuts (5). Tighten nuts to 165-180 lb-ft (224-244 Nm).
10. Install two new cotter pins (6) through two castellated nuts (5).
11. On left side, install drag link (1) and castellated nut (3). Tighten nut to 165-180 lb-ft (224-244 Nm).
12. Install new cotter pin (2) through castellated nut (3).
13. Install ABS sensor (WP 0091 00).
14. Install front brake spider and brake chamber bracket (WP 0123 00).

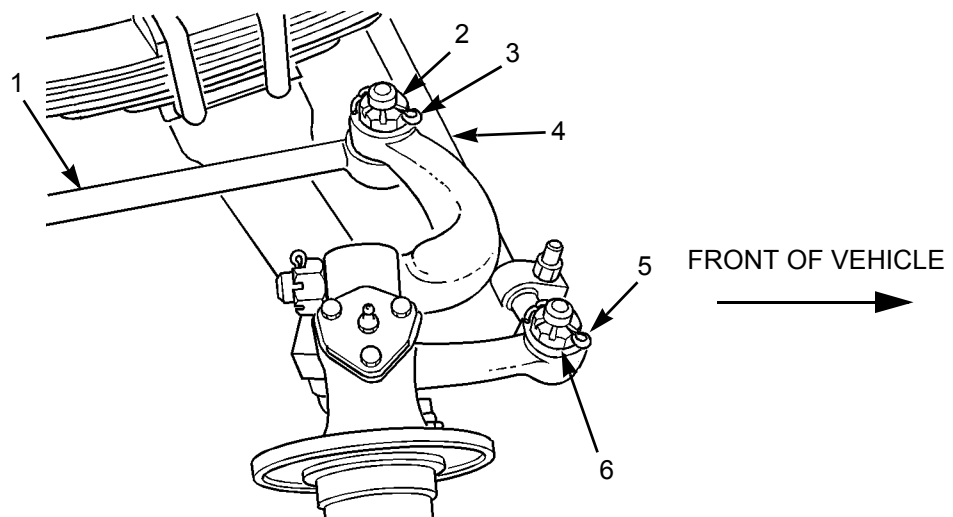

402-631

**END OF WORK PACKAGE**



**FRONT AXLE REPLACEMENT (M915A4R2)****0249 01****THIS WORK PACKAGE COVERS**

Removal, Installation

**INITIAL SETUP****Maintenance Level**

Direct Support

**Tools and Special Tools**

Tool kit, general mechanic's (Item 102, WP 0313 00)

Jack, hydraulic (Item 52, WP 0313 00)

Wrench, torque, 50-250 lb-ft (Item 111, WP 0313 00)

Wrench, torque, 100-600 lb-ft (Item 112, WP 0313 00)

Wrench set, socket, 3/4 in drive (Item 113, WP 0313 00)

**Materials/Parts**

Compound, antiseize (Item 11, WP 0312 00)

Compound, sealing (Item 16, WP 0312 00)

Pin, cotter (P/N MS24665-359) (3)

**Personnel Required**

Two

**Equipment Condition**

Front brake spider and brake chamber bracket removed (WP 0123 00)

ABS sensors removed (WP 0091 00)

Front shock absorbers removed (WP 0173 01)

**WARNING**

Use extreme caution when handling heavy parts. Provide adequate support and use assistance during procedure. Ensure that any lifting device used is in good condition and of suitable load capacity. Keep clear of heavy parts supported only by lifting device. Failure to follow this warning may result in death or injury to personnel.

**REMOVAL****NOTE**

Procedure is the same for both sides except where noted.

1. On left side, remove cotter pin (2) and castellated nut (1) and set drag link (6) aside. Discard cotter pin.
2. Remove two cotter pins (4), castellated nuts (5), and tie rod (3). Discard cotter pins.

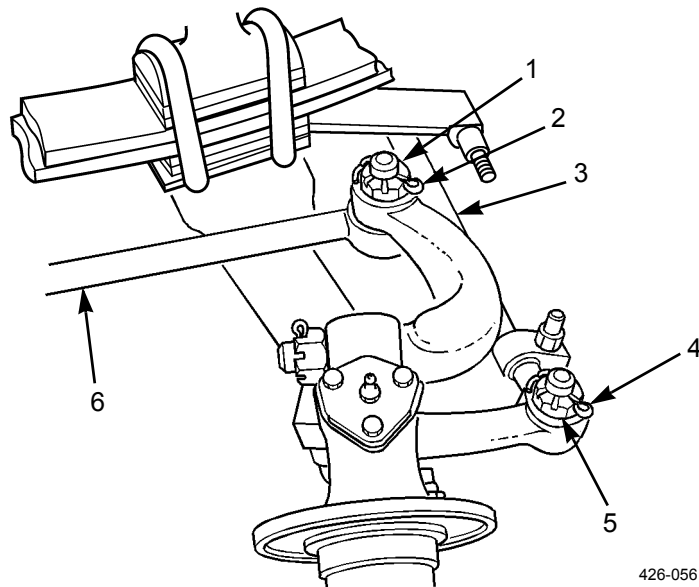
**WARNING**

Front axle weighs 1060 lb (481 kg). Support front axle with a suitable floor jack during removal to prevent possible injury to personnel.

**NOTE**

Ensure front of vehicle is blocked up enough to allow removal of axle.

3. Position suitable floor jack under center of axle (16) and secure axle to floor jack.

**NOTE**

Note position of axle stops during removal to aid in installation.

4. Remove eight nuts (14), and washers (15), four U-bolts (8), two axle stops (7), and two spacers (9).
5. Lower axle (16) and remove axle from two spring assemblies (17). Move axle away from front of vehicle.
6. Remove shock absorber bracket (10), spacer (12), and shim (13) from top of axle (16).
7. Remove pin (11) from axle (16).

**REMOVAL - CONTINUED**

8. Using lifting device, remove axle (16) from floor jack.

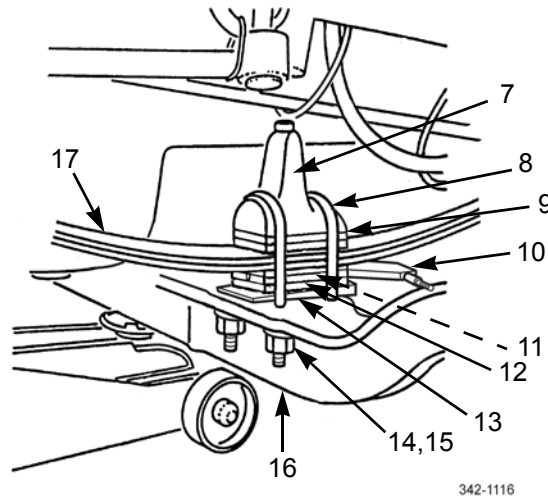
**INSTALLATION****WARNING**

Front axle weighs 1060 lb (481 kg). Support front axle with a suitable floor jack during removal to prevent possible injury to personnel.

**NOTE**

Procedure is the same for both sides except where noted.

1. Install pin (11) into axle (16).
2. With axle (16) installed and secured on suitable floor jack, position axle at front of vehicle.
3. Coat bottom of shim (13) with sealing compound and install shim on axle (16) with wide end of shim toward rear of vehicle.
4. Position spacer (12) and shock absorber bracket (10) to top of shim (13).
5. Coat contact area of shock absorber bracket (10) with sealing compound.
6. Position axle (16) to two spring assemblies (17).
7. Coat U-bolt saddles of two axle stops (7) with sealing compound. Coat threads of U-bolts (8) with antiseize compound.
8. Install two axle stops (7), four U-bolts (8), eight washers (15), and eight nuts (14) to axle (16). Tighten nuts to 380-460 lb-ft (515-624 Nm).
9. Remove floor jack from under vehicle.
10. Install tie rod (3) and two castellated nuts (5). Tighten nuts to 165-180 lb-ft (224-244 Nm).
11. Install two new cotter pins (4) through castellated nuts (5).
12. On left side, install drag link (6) and castellated nut (1). Tighten nut to 165-180 lb-ft (224-244 Nm).
13. Install new cotter pin (2) through castellated nut (1).

***INSTALLATION - CONTINUED***

14. Install front shock absorbers (WP 0173 01).
15. Install ABS sensors (WP 0242 00).
16. Install front brake spider and brake chamber bracket (WP 0123 00).

**END OF WORK PACKAGE**

**THIS WORK PACKAGE COVERS**

Adjustment

**INITIAL SETUP**

**Maintenance Level**

Direct Support

**Tools and Special Tools**

Tool kit, general mechanic's (Item 102, WP 0313 00)

Wrench, torque, 100-600 lb-ft (Item 112, WP 0313 00)

**Tools and Special Tools - Continued**

Wrench set, socket, 3/4 in drive (Item 113, WP 0313 00)

**Materials/Parts**

Compound, antiseize (Item 11, WP 0312 00)

**ADJUSTMENT**

**NOTE**

The following caster adjustment must be performed with the assistance of a local Freightliner dealer or a supporting Contractor Logistic Support (CLS) maintenance activity.

1. Measure caster angle. Angle must be +3.5 to +6.5 degrees.

**NOTE**

Perform steps 2 through 9 if caster angle is incorrect.

2. Remove four nuts (4) and washers (3) from two U-bolts (1).

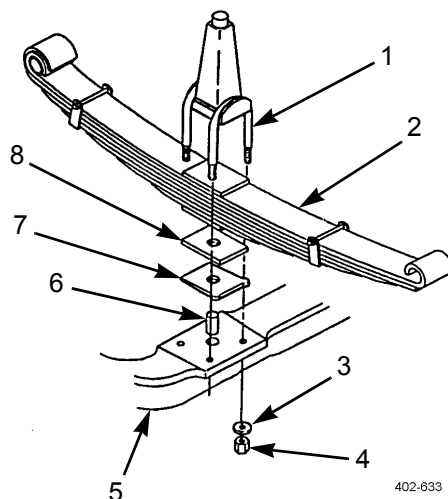

**ADJUSTMENT - CONTINUED****WARNING**

Before removing shim(s), ensure vehicle is properly supported to prevent possible injury to personnel.

3. Raise spring (2) high enough from axle (5) to allow removal of shim(s) (7).
4. Remove spacer (8), shim(s) (7), and dowel (6).
5. Install dowel (6) in axle (5).

**WARNING**

If more than one shim is to be added, shims must be welded together prior to installation. Failure to do so may cause shim slippage resulting in equipment damage and/or injury to personnel.

**NOTE**

Install shims with tapered end toward front of vehicle.

6. Install new shim(s) (7) to obtain +3.5 to +6.5 degrees of caster angle.

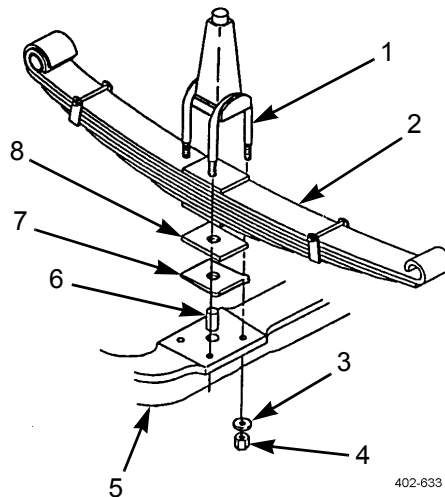
**NOTE**

Ensure dowel protrudes through shim(s) enough to hold spacer in place. If dowel does not protrude into spacer, replace dowel.

7. Install spacer (8).
8. Lower spring (2) onto axle (5).
9. Coat threads of two U-bolts (1) with antiseize compound.
10. Install four washers (3) and nuts (4) on two U-bolts (1). Tighten nuts to 380-460 lb-ft (515-624 Nm).

**END OF WORK PACKAGE**



---

**TIE ROD MAINTENANCE**

---

0251 00

**THIS WORK PACKAGE COVERS**Removal, Disassembly, Assembly, Installation

---

**INITIAL SETUP****Maintenance Level**

Direct Support

**Materials/Parts**

Pin, cotter (P/N MS24665-359) (2)

**Tools and Special Tools**

Tool kit, general mechanic's (Item 102, WP 0313 00)

Wrench, torque, 50-250 lb-ft (Item 111, WP 0313 00)

**References**WP 0118 00

---

**REMOVAL**

Remove cotter pin (2) and castellated nut (3) at each end of tie rod (1). Remove tie rod. Discard cotter pins.

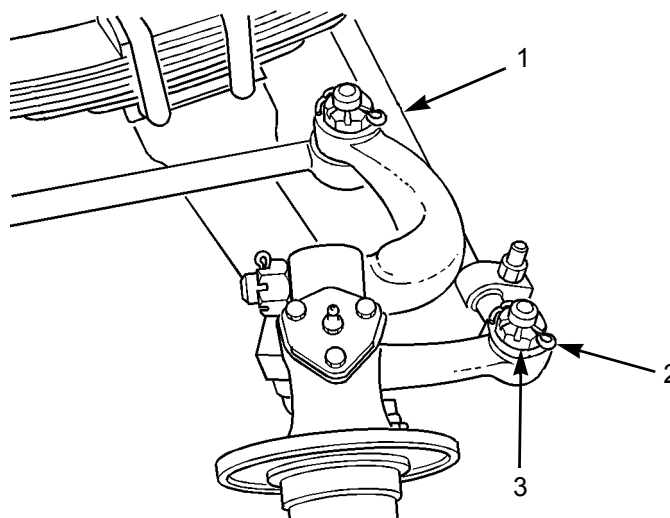

402-631

**DISASSEMBLY****NOTE**

Procedure is the same for both tie rod ends.

1. Remove locknut (4) and capscrew (8).
2. Remove dust cover (5).

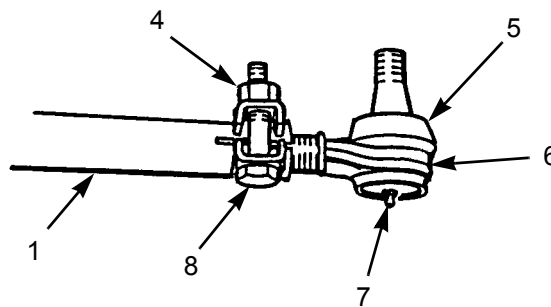

402-634

**NOTE**

- Note number of turns necessary to remove tie rod end.
- Left tie rod end has left-hand threads and right tie rod end has right-hand threads.

3. Remove tie rod end (6) from tie rod (1).
4. If damaged, remove lubrication fitting (7).

**ASSEMBLY****NOTE**

Procedure is the same for both tie rod ends.

1. If removed, install new lubrication fitting (7).

**NOTE**

Left tie rod end has left-hand threads and right tie rod end has right-hand threads.

2. Install tie rod end (6) on tie rod (1), the same number of turns noted during disassembly.
3. Install dust cover (5).
4. Install capscrew (8) and locknut (4).

**INSTALLATION**

1. Install each end of tie rod (1) with castellated nut (3) and new cotter pin (2). Tighten castellated nuts to 165-180 lb-ft (224-244 Nm).

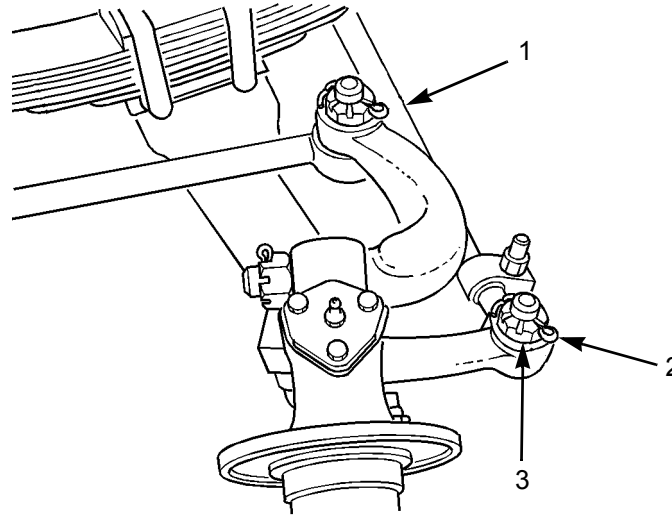

402-631

2. Check front axle toe-in alignment (WP 0118 00).

**END OF WORK PACKAGE**



**FRONT CROSS TUBE ARM REPLACEMENT**

**0252 00**

**THIS WORK PACKAGE COVERS**

Removal, Installation

**INITIAL SETUP**

**Maintenance Level**

Direct Support

**Tools and Special Tools**

Tool kit, general mechanic's (Item 102, WP 0313 00)

Multiplier, torque wrench (Item 61, WP 0313 00)

Wrench, torque, 100-600 lb-ft (Item 112, WP 0313 00)

**Tools and Special Tools - Continued**

Wrench set, socket, 3/4 in drive (Item 113, WP 0313 00)

**Materials/Parts**

Pin, cotter (P/N MS24665-499)

**Equipment Condition**

Tie rod removed (WP 0251 00)

**REMOVAL**

**NOTE**

Procedure is the same for both cross tube arms.

Remove cotter pin (3), castellated nut (2), cross tube arm (4), and woodruff key (1). Discard cotter pin.

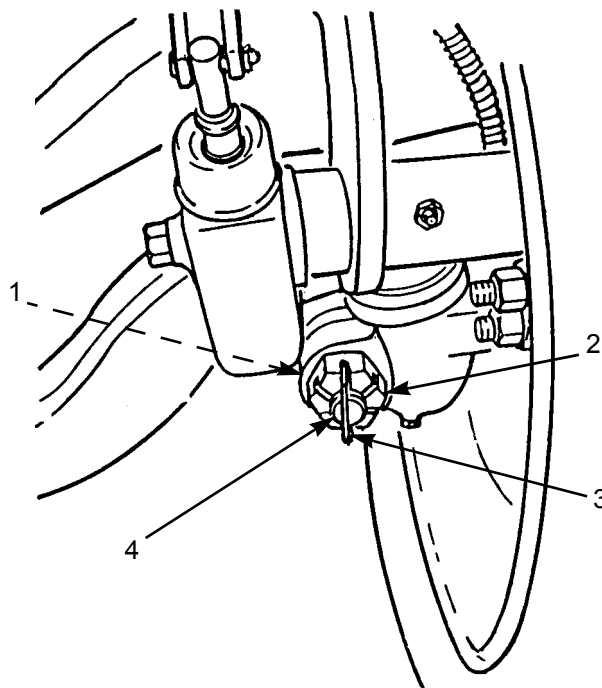

402-635

**INSTALLATION****NOTE**

Procedure is the same for both cross tube arms.

1. Install woodruff key (1), cross tube arm (4), and castellated nut (2). Tighten castellated nut to 550-740 lb-ft (746-1003 Nm).

**CAUTION**

Castellated nut may be tightened to 1,025 lb-ft (1390 Nm) for purpose of installing cotter pin. Overtightening may damage steering arm.

2. Install new cotter pin (3).

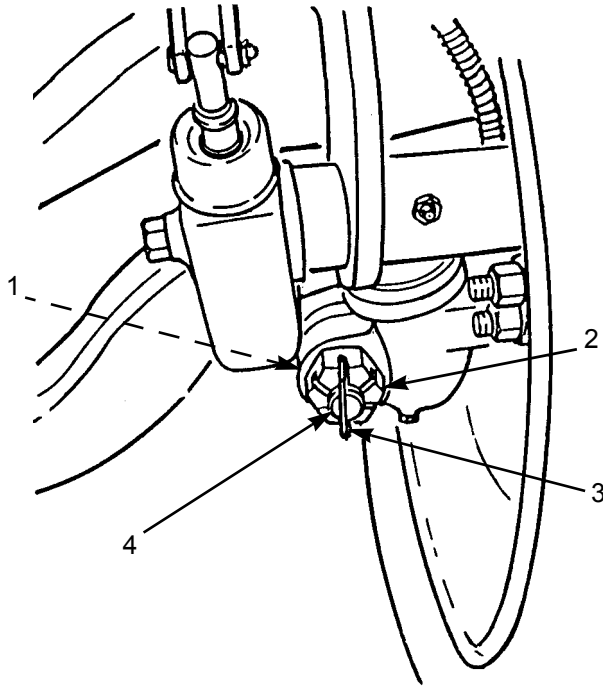

402-635

3. Install tie rod (WP 0251 00).

**END OF WORK PACKAGE**

**FRONT STEERING ARM REPLACEMENT**

**0253 00**

**THIS WORK PACKAGE COVERS**

Removal, Installation

**INITIAL SETUP**

**Maintenance Level**

Direct Support

**Tools and Special Tools**

Tool kit, general mechanic's (Item 102, WP 0313 00)

Multiplier, torque wrench (Item 61, WP 0313 00)

Wrench, torque, 100-600 lb-ft (Item 112, WP 0313 00)

**Tools and Special Tools - Continued**

Wrench set, socket, 3/4 in drive (Item 113, WP 0313 00)

**Materials/Parts**

Pin, cotter (P/N MS24665-499)

**Equipment Condition**

Drag link removed (WP 0158 00)

Front brake spider and brake chamber bracket removed (WP 0123 00)

**REMOVAL**

Remove cotter pin (1), castellated nut (4), steering arm (3), and woodruff key (2). Discard cotter pin.

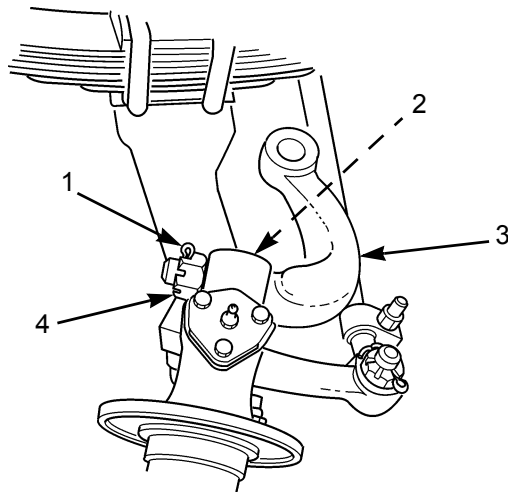

402-636

**INSTALLATION**

1. Install woodruff key (2), steering arm (3), and castellated nut (4). Tighten castellated nut to 775-1,050 lb-ft (1051-1424 Nm).

**CAUTION**

Castellated nut may be tightened to 1,450 lb-ft (1966 Nm) for purposes of installing cotter pin. Overtightening may damage steering arm.

2. Install new cotter pin (1).

---

**FRONT STEERING ARM REPLACEMENT - CONTINUED**

---

**0253 00**

***INSTALLATION - CONTINUED***

3. Install drag link (WP 0158 00).
4. Install front brake spider and brake chamber bracket (WP 0123 00).

**END OF WORK PACKAGE**



**FRONT STEERING KNUCKLE REPLACEMENT**

**0254 00**

**THIS WORK PACKAGE COVERS**

Removal, Installation

**INITIAL SETUP**

**Maintenance Level**

Direct Support

**Tools and Special Tools**

- Tool kit, general mechanic's (Item 102, WP 0313 00)
- Dial indicator set (Item 18, WP 0313 00)
- Driver, bushing (Item 22, WP 0313 00)
- Jack, hydraulic (Item 52, WP 0313 00)
- Press, arbor (Item 71, WP 0313 00)
- Wrench, torque, 15-75 lb-ft (Item 110, WP 0313 00)

**Materials/Parts**

- Tags, marker (Item 42, WP 0312 00)
- Bushing (P/N R210088) (2)
- Gasket (P/N 3208-M-1027) (2)
- Seal assembly (P/N A-1205-X-1428) (4)
- Shim (P/N 2203-K-3001)
- Shim (P/N 2203-L-3002)

**References**

- TM 9-2320-303-10
- WP 0024 00

**Equipment Condition**

- Tie rod removed (WP 0251 00)
- Front cross tube arm removed (WP 0252 00)
- Front steering arm removed (WP 0253 00)

**NOTE**

Procedure is the same for both steering knuckles.

**REMOVAL**

1. If damaged, remove two lubrication fittings (3).
2. Remove six cap screws (1), flat washers (2), two caps (6), gaskets (5), and seal assemblies (4). Discard gaskets and seal assemblies.
3. Remove two nuts (7).

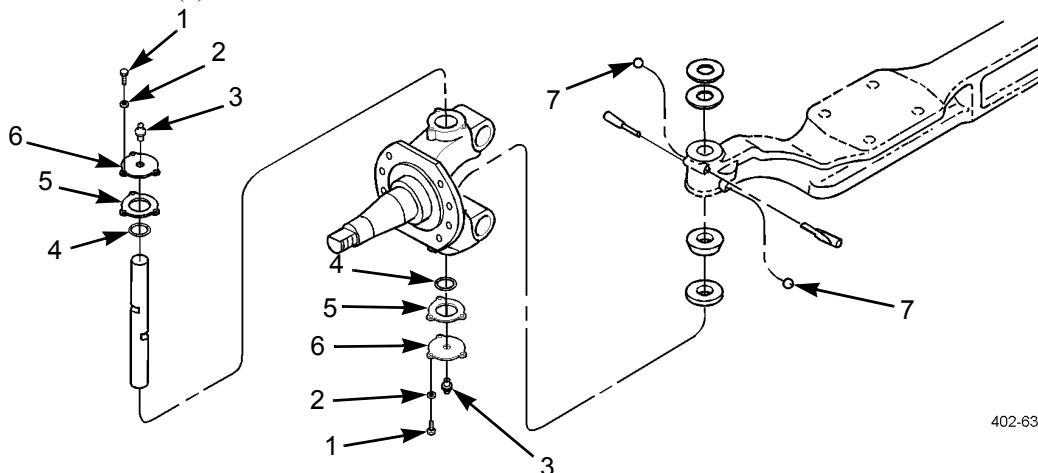

402-637

**REMOVAL - CONTINUED****NOTE**

Tag draw keys prior to removal to aid in installation.

4. Remove two draw keys (11).

**CAUTION**

Be careful when removing pin. If pin is dropped, damage may occur.

5. Remove pin (8).
6. Remove steering knuckle (9), thrust bearing (13), shim(s) (10), and seal assembly (12). Discard seal assembly and shim(s).

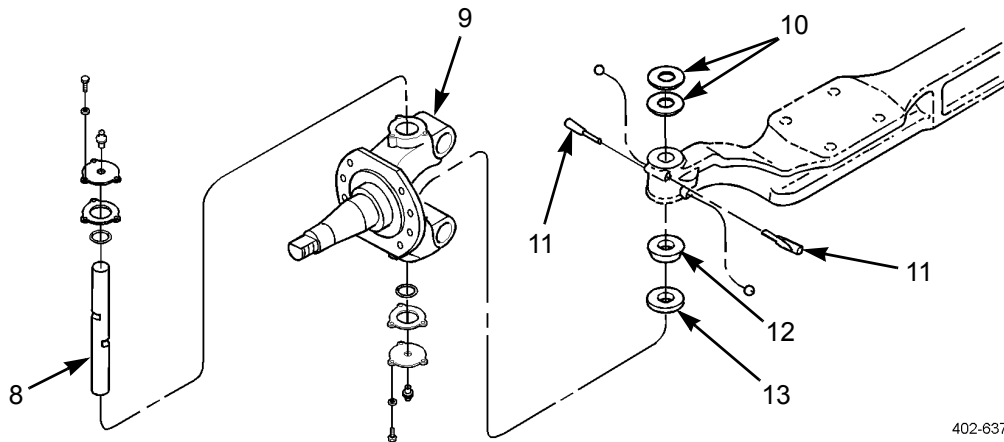

7. Remove two bushings (14) from steering knuckle (9). Discard bushings.

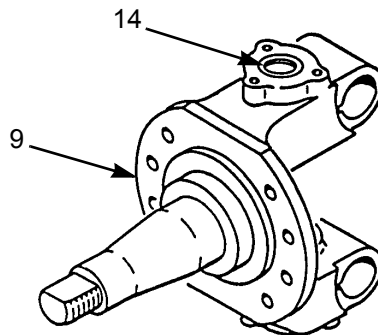

402-638

**INSTALLATION**

1. Using bushing driver, install two new bushings (14) as follows:
  - a. Press bushing (14) into steering knuckle (9) 1/8 in (3.2 mm) and relieve pressure.
  - b. Press bushing (14) into steering knuckle (9) another 1/2 in (12.7 mm) and relieve pressure.

**INSTALLATION - CONTINUED**

- c. Press bearing (14) into steering knuckle (9) another 5/16 in (7.9 mm) below seal counterbore.

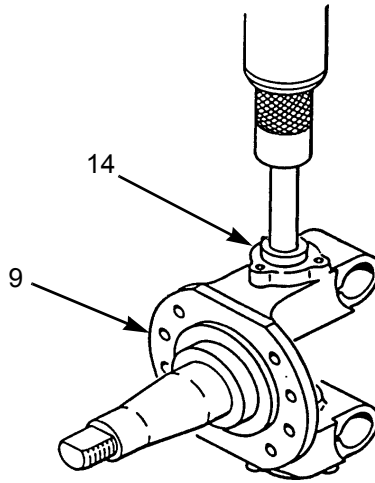

402-639

2. Install new seal assembly (12) on chamfered side of thrust bearing (13).
3. Install steering knuckle (9).
4. Install thrust bearing (13) and seal assembly (12).
5. Using suitable jack, raise steering knuckle (9) until seal assembly (12) is flush with bottom side of axle.
6. Using thickness gage, measure and record distance between top side of axle and steering knuckle (9).

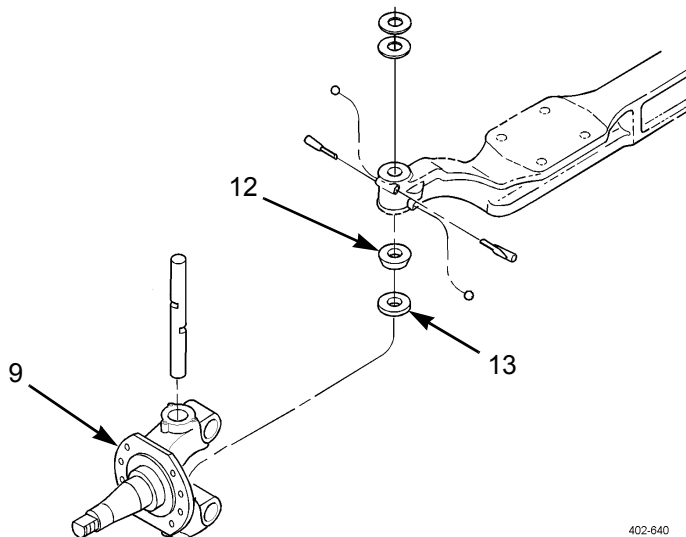

402-640

**INSTALLATION - CONTINUED****WARNING**

Shims are delicate and sharp. Use extreme caution when aligning shims to prevent cutting fingers or bending inside diameter of shims. Damage to shims will require complete disassembly and replacement of damaged parts.

7. Install new shims (10) of thickness equal to measurement from step 6.

**CAUTION**

Ensure shim(s) is not blocking passage for pin installation to prevent damage to equipment.

**NOTE**

- Ensure draw key slots align with draw key holes.
- If pin will not pass completely through steering knuckle, but did pass through shim(s), lower jack to align thrust bearing and seal assembly to allow passage of pin.

8. Install pin (8) in steering knuckle (9).
9. Install two draw keys (11) and nuts (7). Tighten nuts to 30-40 lb-ft (41-54 Nm).

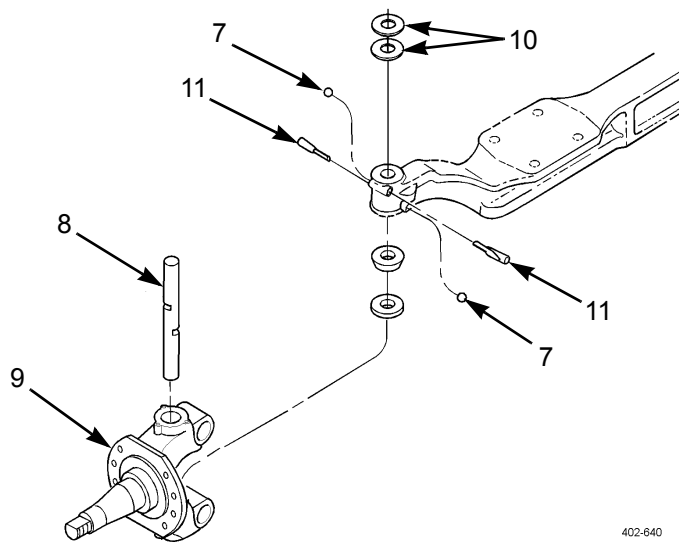

402-640

10. Position steering knuckle (9) in straight-ahead position and install dial indicator on steering knuckle as shown.
11. Pry up on steering knuckle (9) while observing dial indicator. Vertical end play must be 0.001-0.025 in (0.03-0.64 mm). If vertical end play is less than 0.001 in (0.03 mm), remove shim(s) (10) to achieve vertical end play. If vertical end play is more than 0.025 in (0.64 mm), add shim(s) to reduce vertical end play.
12. If shim(s) (10) is to be added or removed, perform removal steps 3 through 7 and installation steps 1 through 11 until correct vertical end play is achieved.

INSTALLATION - CONTINUED

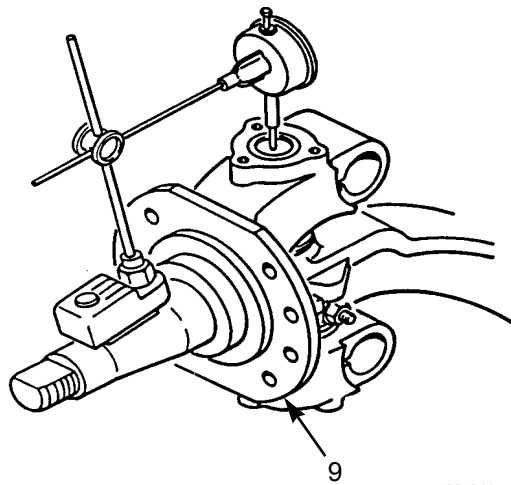

402-641

13. Install two new seal assemblies (4), new gaskets (5), caps (6), six flat washers (2), and cap screws (1). Tighten cap screws to 20-30 lb-ft (27-41 Nm).
14. If removed, install two new lubrication fittings (3).

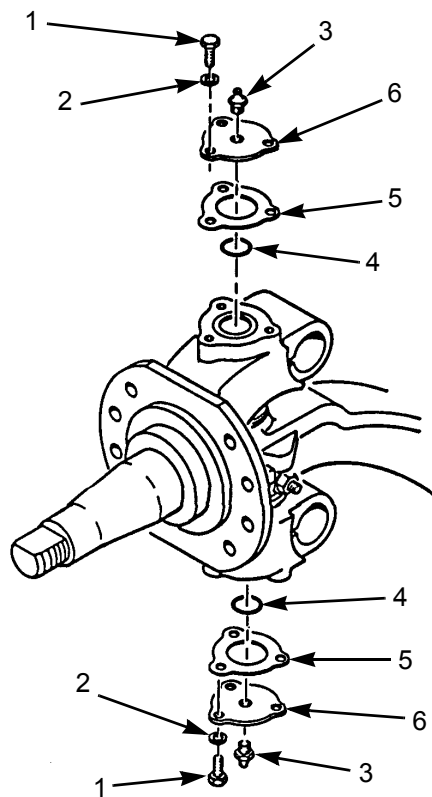

402-642

---

**FRONT STEERING KNUCKLE REPLACEMENT - CONTINUED**

---

**0254 00**

***INSTALLATION - CONTINUED***

15. Install front steering arm (WP 0253 00).
16. Install front cross tube arm (WP 0252 00).
17. Install tie rod (WP 0251 00).
18. Lubricate steering knuckle (WP 0024 00).

**END OF WORK PACKAGE**

---

**REAR AXLE REPLACEMENT****0255 00**

---

**THIS WORK PACKAGE COVERS**Removal, Installation

---

**INITIAL SETUP****Maintenance Level**

Direct Support

**Tools and Special Tools**

Tool kit, general mechanic's (Item 102, WP 0313 00)

Jack, hydraulic (Item 52, WP 0313 00)

Wrench, torque, 50-250 lb-ft (Item 111, WP 0313 00)

**Materials/Parts**

Nut, lock (P/N 23-09247-210) (16)

**Equipment Condition**

Air system drained (TM 9-2320-303-10)

Rear brakeshoes and linings removed (WP 0124 00)

Drivelines removed (WP 0116 00)

Rear anti-lock brake system (ABS) sensors removed (WP 0092 00)

Axle oil drained (WP 0120 00)

---

**REMOVAL****WARNING**

Axle housing is heavy and can injure personnel if dropped. Support axle housing during removal.

**NOTE**

Procedure is the same for all rear axles except where noted.

**REMOVAL - CONTINUED**

1. Disconnect two air lines (6) from brake chamber (5).

**NOTE**

Note position of spider assembly prior to removal to aid in installation.

2. Remove eight locknuts (1), eight washers (2), eight screws (3), eight washers (4), and spider assembly (8) from axle housing (7).
3. Repeat steps 1 and 2 for opposite side of axle housing (7).

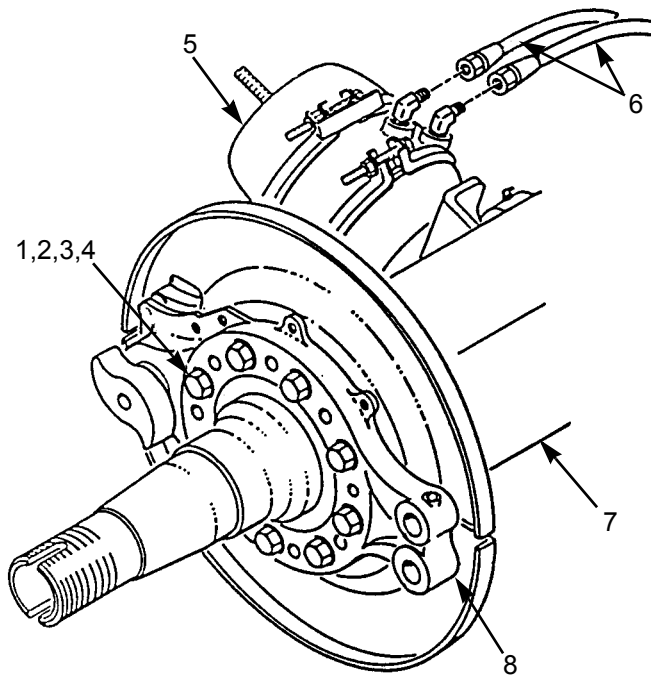

402-643

**NOTE**

If axle is to be reinstalled, tag spacers.

4. Remove two nuts (14), two washers (13), two screws (10), two washers (11), spacer(s) (12) if installed, and torque rod (9). Move torque rod out of the way.

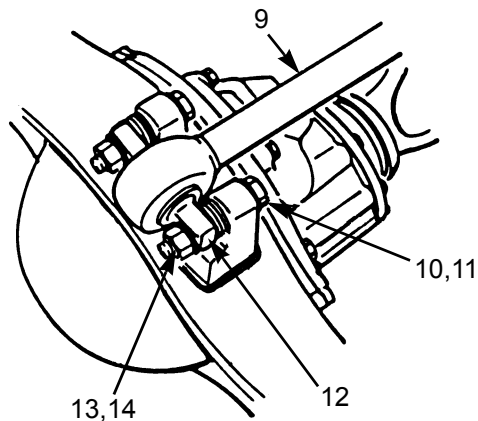

402-644



**REMOVAL - CONTINUED**

5. Place suitable jack under equalizing beam saddle cap (15) and raise tandem until companion axles and wheels are off the ground. Lower until wheels cannot be rotated by hand.
6. Repeat step 5 for opposite side of tandem.

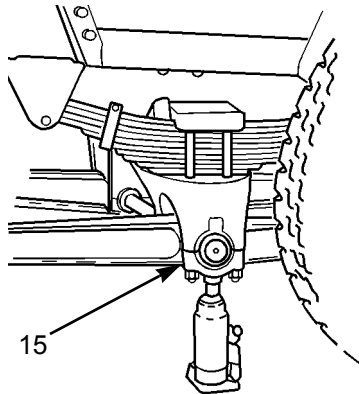

402-645

7. Using suitable roller jack, support axle housing (7).
8. Remove nut (16), washer (17), screw (18), washer (19), and two bushings (20).
9. Repeat step 8 for opposite side.

**NOTE**

If axle housing is being replaced, remove differential carrier assembly in accordance with WP 0256 00 for forward-rear axle or WP 0258 00 for rear-rear axle.

10. Separate axle housing (7) from equalizing beam (21) and move axle housing from under vehicle.

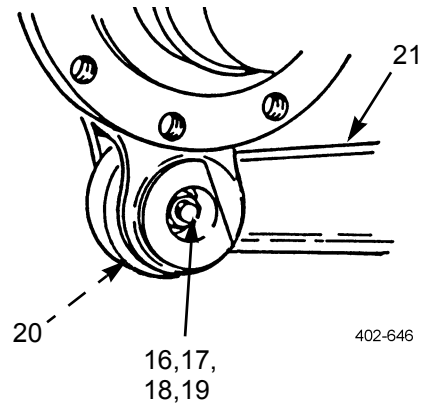
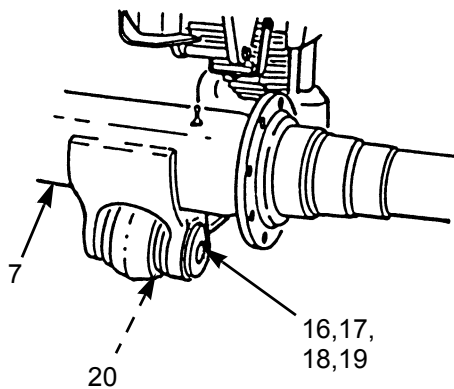

402-646

**INSTALLATION**

**WARNING**

Axle housing is heavy and can injure personnel if dropped. Support axle housing during installation.

**NOTE**

- Procedure is the same for all rear axles except where noted.
- If axle housing was replaced, install differential carrier assembly in accordance with WP 0256 00 for forward-rear axle or WP 0258 00 for rear-rear axle.

1. Align axle housing (7) with equalizing beam end (21) and install two bushings (20), washer (16), screw (17), washer (18), and new locknut (19). Tighten screw to 210-240 lb-ft. (285-325 Nm).

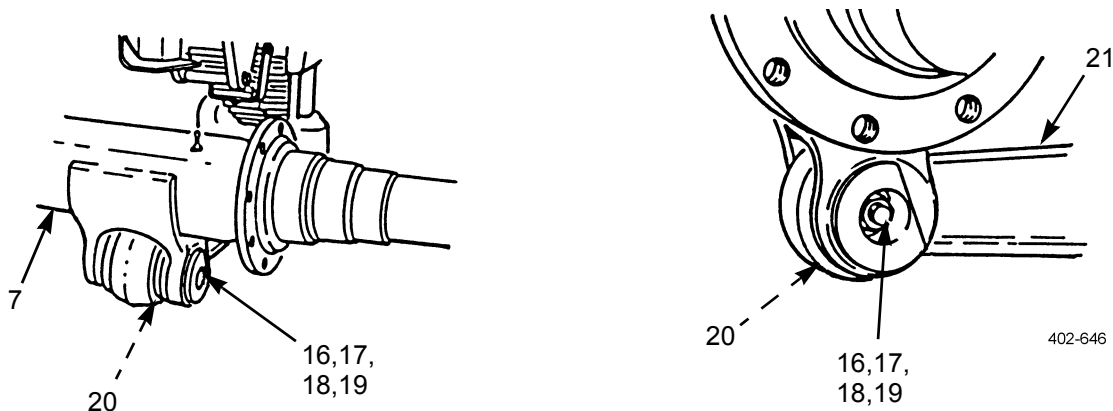

2. Repeat step 1 for opposite side.

**NOTE**

If reinstalling axle, perform step 3. If installing new axle, perform step 4.

3. Install torque rod (9), any spacer(s) (12), two washers (10), two screws (11), two washers (14), and two new locknuts (13). Tighten locknuts to 120-152 lb-ft (163-206 Nm).
4. Install torque rod (9), two washers (10), two screws (11), two washers (14), and two new locknuts (13). Hand-tighten locknuts.

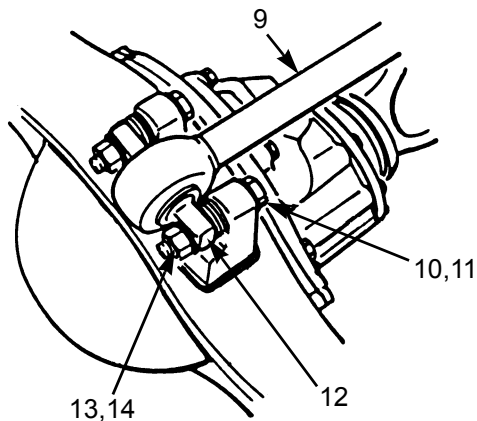

**INSTALLATION - CONTINUED**

5. Install spider assembly (8), eight washers (1), eight screws (2), eight washers (3), and eight new locknuts (4) on axle housing (7). Tighten locknuts to 135-145 lb-ft (183-197 Nm).
6. Connect two air lines (6) in brake chamber (5).

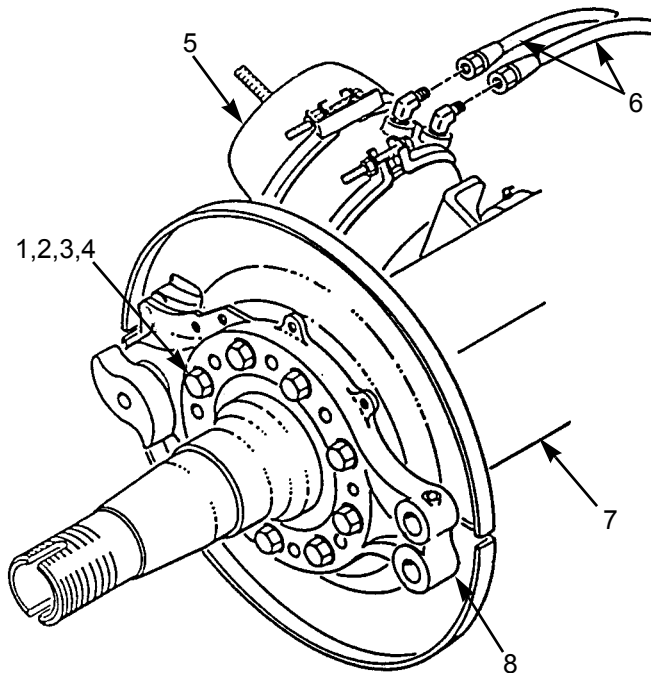

402-643

7. Install rear brakeshoes and linings (WP 0124 00).
8. Fill axle with oil (WP 0120 00).
9. Install rear anti-lock brake system (ABS) sensors (WP 0092 00).

**END OF WORK PACKAGE**



---

**FORWARD-REAR AXLE DIFFERENTIAL CARRIER REPLACEMENT**

---

**0256 00**

**THIS WORK PACKAGE COVERS**

Removal, Installation

---

**INITIAL SETUP**

**Maintenance Level**

Direct Support

**Tools and Special Tools**

Tool kit, general mechanic's (Item 102, WP 0313 00)

Jack, hydraulic (Item 52, WP 0313 00)

Wrench, torque, 50-250 lb-ft (Item 111, WP 0313 00)

**Materials/Parts**

Compound, sealing (Item 15, WP 0312 00)

Rags, wiping (Item 39, WP 0312 00)

**Personnel Required**

Two

**References**

TM 9-2320-303-10

**Equipment Condition**

Air system drained (TM 9-2320-303-10)

Drivelines disconnected (WP 0116 00)

Axle oil filter removed (WP 0120 00)

Axle oil drained (WP 0120 00)

---

**WARNING**

- Forward-rear axle differential carrier weighs 1,160 lb (526 kg). Attach suitable floor jack prior to removal or installation to prevent possible injury to personnel.
- Adhesives, solvents, and sealing compounds can burn easily, can give off harmful vapors, and are harmful to skin and clothing. To avoid injury or death, keep away from open fire and use in well-ventilated area. If adhesive, solvent, or sealing compound gets on skin or clothing, wash immediately with soap and water.

**REMOVAL**

1. Disconnect air line (3).

**WARNING**

Forward-rear axle differential carrier weighs 1,160 lb (526 kg). Attach suitable floor jack prior to removal to prevent possible injury to personnel.

**NOTE**

If axle assembly has been removed from vehicle, perform steps 2 and 3 only.

2. Remove 10 capscrews (4), 10 washers (5), two nuts (1), and two washers (2).
3. Loosen differential carrier (7) by tapping around flange.
4. Remove differential carrier (7) from axle (6) and lower differential carrier onto floor jack. Roll differential carrier from under vehicle.

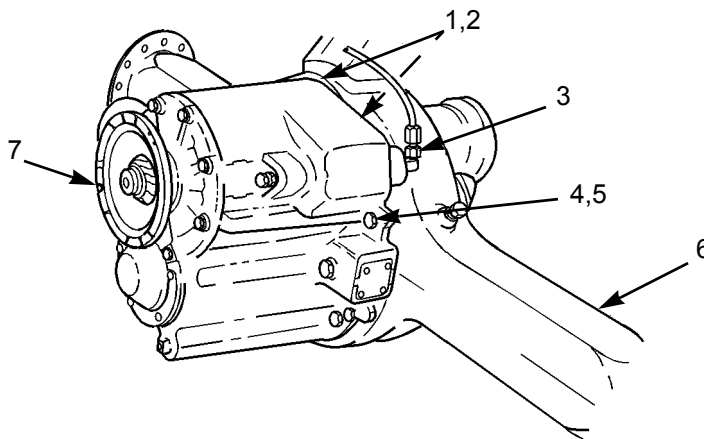

402-647

5. If damaged, remove oil filter adapter (8).

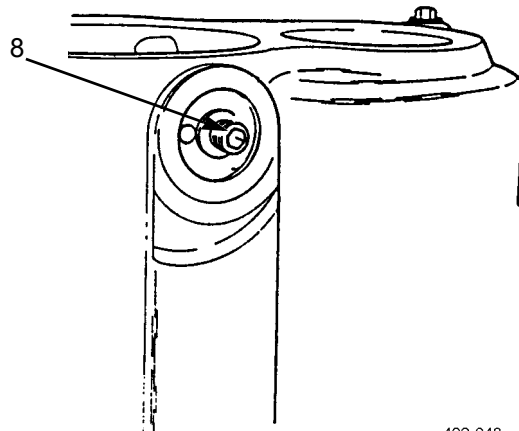

402-648

**INSTALLATION**

1. If removed, install new oil filter adapter (8).

**WARNING**

Forward-rear axle differential carrier weighs 1,160 lb (526 kg). Attach suitable floor jack prior to installation to prevent possible injury to personnel.

**CAUTION**

Make sure both mating surfaces have been completely cleaned to prevent damage to equipment.

2. Install differential carrier (7) on floor jack and roll differential carrier into position under vehicle.

**WARNING**

Adhesives, solvents, and sealing compounds can burn easily, can give off harmful vapors, and are harmful to skin and clothing. To avoid injury or death, keep away from open fire and use in well-ventilated area. If adhesive, solvent, or sealing compound gets on skin or clothing, wash immediately with soap and water.

**NOTE**

If axle assembly has been removed from vehicle, perform steps 3 through 5 only.

3. Apply 1/8-in. bead of sealing compound around mating surface of axle (6).
4. Attach suitable hoist and install differential carrier (7), two washers (1), and two nuts (2). Do not tighten nuts.
5. Install 10 washers (5) and 10 capscrews (4). Tighten 10 capscrews and two nuts to 150-230 lb-ft (203-312 Nm).
6. Connect air line (3).
7. Install axle oil filter (WP 0120 00).
8. Connect drivelines (WP 0116 00).
9. Fill axle with oil (WP 0120 00).

**END OF WORK PACKAGE**





**THIS WORK PACKAGE COVERS**

Disassembly, Cleaning, Inspection, Repair or Replacement, Assembly

**INITIAL SETUP**

**Maintenance Level**

General Support

**Tools and Special Tools**

Tool kit, general mechanic's (Item 102, WP 0313 00)

Dial indicator set (Item 18, WP 0313 00)

Gloves, welder's (Item 29, WP 0313 00)

Holding bar, pinion (Item 35, WP 0313 00)

Multiplier, torque wrench (Item 61, WP 0313 00)

Press, arbor (Item 71, WP 0313 00)

Puller, universal (Item 73, WP 0313 00)

Wrench, strap (Item 107, WP 0313 00)

Wrench, torque, 0-300 lb-in (Item 109, WP 0313 00)

Wrench, torque, 15-75 lb-ft (Item 110, WP 0313 00)

Wrench, torque, 100-600 lb-ft (Item 112, WP 0313 00)

**Materials/Parts**

Adhesive, silicone rubber (Item 5, WP 0312 00)

Detergent (Item 18, WP 0312 00)

Grease, GAA (Item 23, WP 0312 00)

**Materials/Parts - Continued**

Oil, lubricating (Item 33, WP 0312 00)

Paste, Prussian blue (Item 36, WP 0312 00)

Rags, wiping (Item 39, WP 0312 00)

Solder (Item 40, WP 0312 00)

Cotter pin (P/N 1199-R-2176) (2)

Gasket (P/N 2208-C-445)

Gasket (P/N 3208-Y-25)

Nut, lock (P/N 40X-1026)

Nut, lock (P/N 40X-1145)

Seal, oil (P/N A-1205-W-1895)

Seal, o-ring (P/N 5X-1034) (2)

**Personnel Required**

Two

**References**

TM 9-214

**Equipment Condition**

Forward-rear axle differential carrier removed (WP 0260 00)



**WARNING**



Forward-rear axle differential carrier weighs 1160 lb (526 kg). Attach suitable lifting device when lifting assembly to prevent possible injury to personnel.

**OUTPUT SHAFT REMOVAL AND DISASSEMBLY**a. **Removal.**

- (1) Disconnect inter-axle driveline from yoke (3) of output shaft (14). (Refer to WP 0116 00).

**NOTE**

It may be necessary to use a yoke puller to remove the yoke from the shaft.

- (2) Remove nut (1), washer (2), yoke (3) and bushing (4) from output shaft (14).
- (3) Remove four capscrews (8) and washers (9) and pull the cage (12) and shaft assembly from the axle housing. To free the cage from the housing, it may be necessary to tap the shaft and cage with a soft mallet. Care must be taken not to damage seal. Remove and discard gasket (13).

b. **Disassembly.****CAUTION**

The spacer diameter must be less than the outer diameter of the output shaft to avoid damaging the oil seal and bearings.

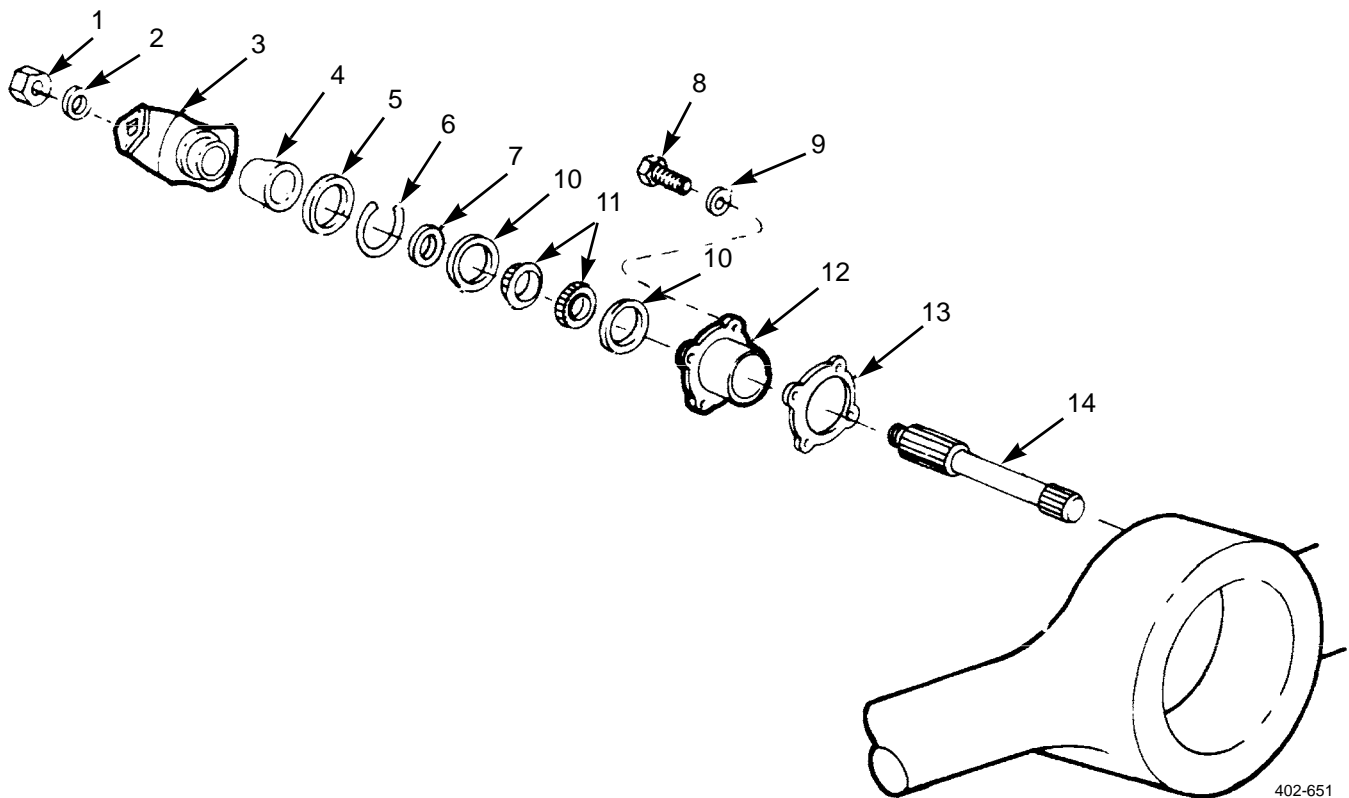

- (1) Press the output shaft (14) from the cage (12) by placing the shaft and cage in a press. Position cage to the top. Use a spacer against the output shaft threaded end and press the output shaft from the cage.

**OUTPUT SHAFT REMOVAL AND DISASSEMBLY - CONTINUED****NOTE**

The oil seal, snap ring spacer and bearings will remain in the bearing cage. If disassembly is required, continue with step *b*; otherwise set aside for assembly.

- (2) Remove the oil seal (5) from the cage (12), using a suitable tool such as a screwdriver to pry seal out. Be careful not to damage the inner diameter of the cage. Discard seal after removal.
- (3) Remove the retaining ring (6) from its groove in the cage inner diameter using retaining ring pliers.
- (4) Remove washer (7), two bearing cups (10) and two bearing cones (11) from cage (12).

**DIFFERENTIAL CARRIER DISASSEMBLY****a. Remove Gear Cover Assembly.**

- (1) Place the complete differential carrier (19) in a suitable repair stand. Lift the unit by the input (front) yoke (15) using a chain fall.
- (2) Place the differential carrier (19) in an upright position (input yoke pointing upward).
- (3) Using a suitable wrench or socket, loosen the input yoke nut (16). However, do not remove. Leave the nut and yoke on the input shaft at this time to facilitate gear cover (17) removal.

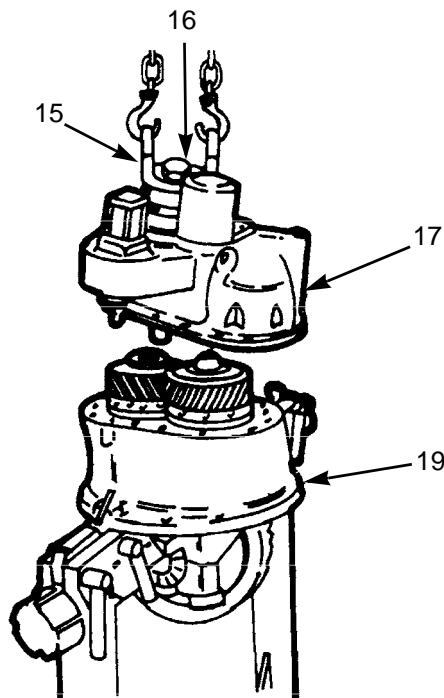

402-652

**DIFFERENTIAL CARRIER DISASSEMBLY - CONTINUED**

- (4) Remove 12 gear cover-to-carrier capscrews (21) and washers (20).

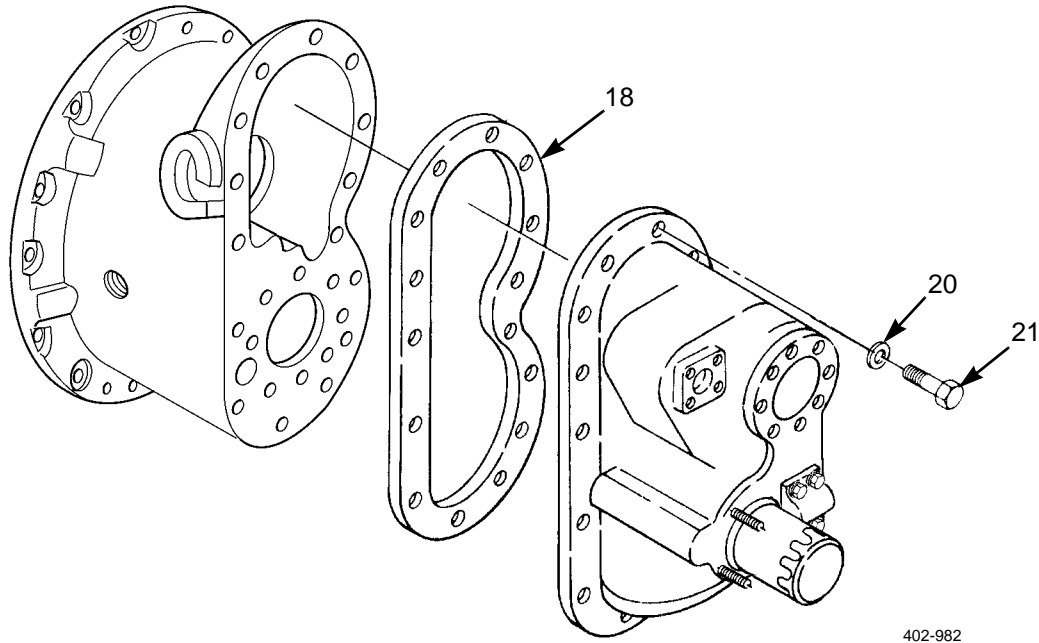

**DIFFERENTIAL CARRIER DISASSEMBLY - CONTINUED****CAUTION**

Do not use pry bars, chisels or wedges to loosen the cover. This will damage the cover and carrier flange mating surfaces.

- (5) Separate the gear cover (17) from the carrier (19) by attaching a chain fall to the input yoke (15). It may be necessary to use a rawhide mallet to break the cover from the carrier.

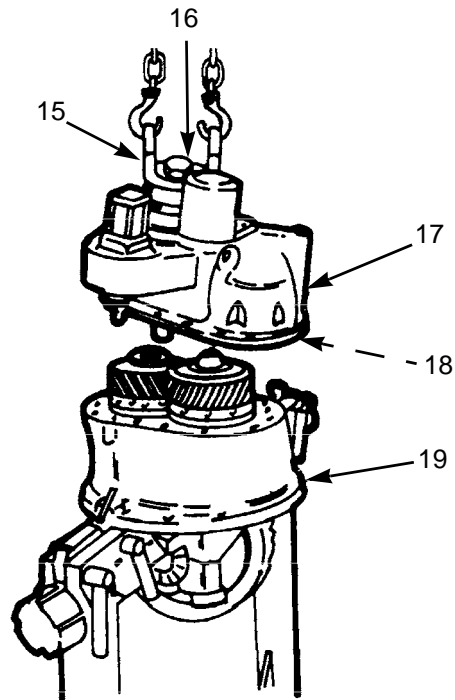

402-652

- (6) After separating the parts, remove the cover-to-carrier gasket (18). Discard gasket.

**DIFFERENTIAL CARRIER DISASSEMBLY - CONTINUED**b. **Remove Oil Filter and Pump.****NOTE**

There may be approximately one pint of lubricant remaining within the filter. Be careful not to spill it when removing the filter.

- (1) Remove two nuts (22) and cover (23). Using a strap wrench, remove filter element (24) from the gear cover (17).

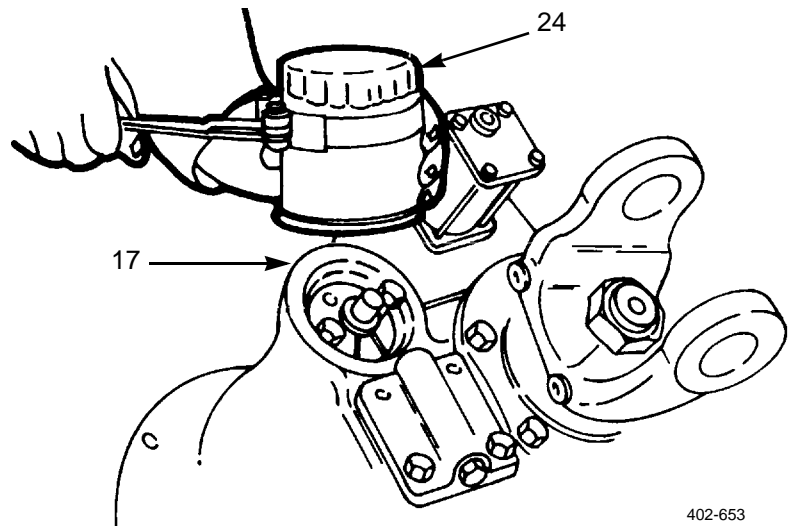
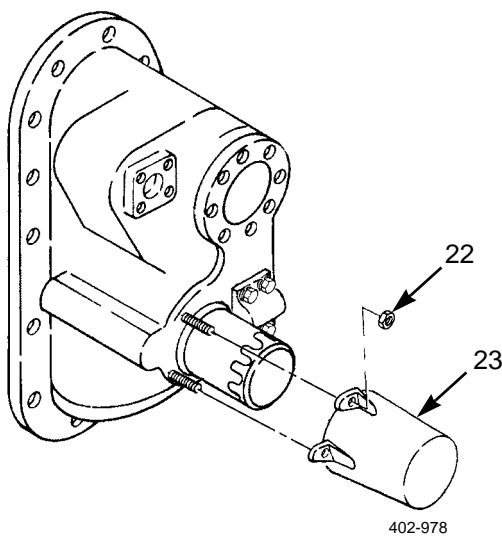

- (2) Disassemble the oil filter adapter (25) from the gear cover (17) by removing capscrews and washers.
- (3) Check the adapter (25) casting and threads on the filter mounting tube. If threads are stripped or casting is cracked, discard and replace during reassembly.

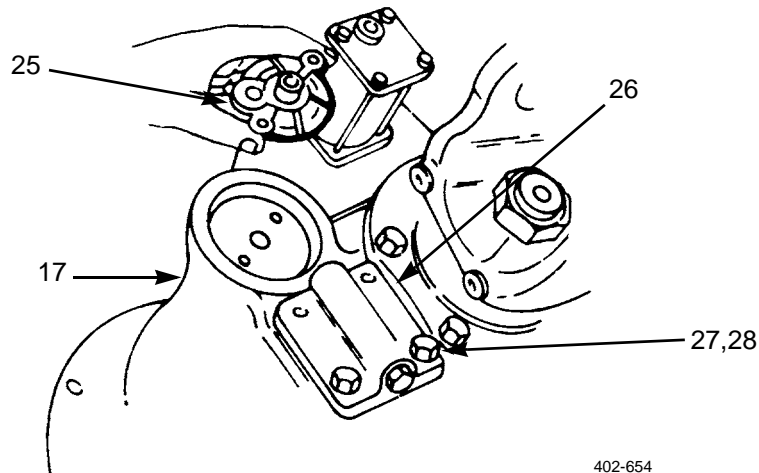

**DIFFERENTIAL CARRIER DISASSEMBLY - CONTINUED**

- (4) Remove two capscrews (27), washers (28) and oil pump relief valve cover (26) assembly.
- (5) Remove the pump oil driven gears (29) from their shaft within the oil pump cavity.

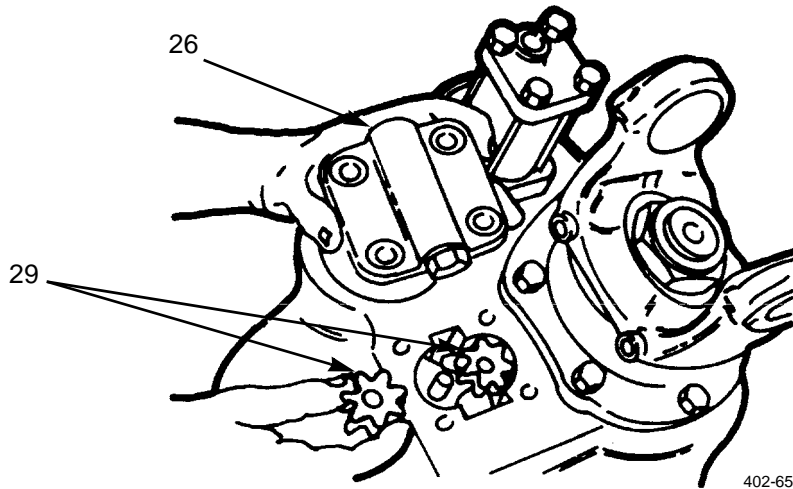

402-655

- (6) Disassemble the oil pump relief valve cover (26) assembly by unthreading the hollow plug (32) and removing the spring (31) and ball (30) from the cover cavity.

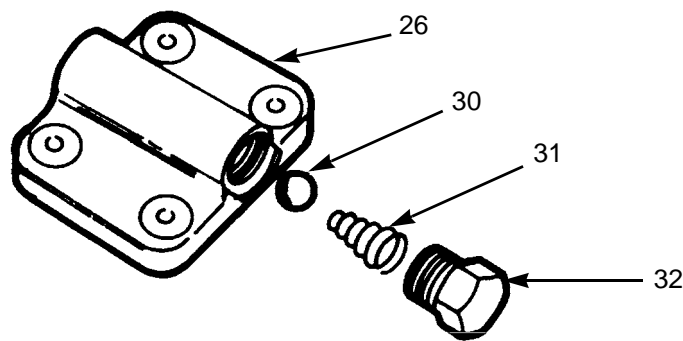

402-656

**DIFFERENTIAL CARRIER DISASSEMBLY - CONTINUED**

- c. **Remove Input Shaft, Forward Bearing, and Shift Collar.**

**NOTE**

To remove the interaxle differential shift collar, it is necessary to disassemble the input shaft from the gear cover. Use the following procedure.

- (1) Remove the input yoke nut and washer from the input shaft (33).

**CAUTION**

If the input oil seal is not to be serviced, care must be taken when pulling the yoke so as not to damage the seal in the bearing. Do not use a hammer to loosen yoke. This will damage the yoke and splines and cause excessive yoke run out and misalignment.

- (2) Remove the input yoke (15) from the input shaft (33) using a yoke puller.

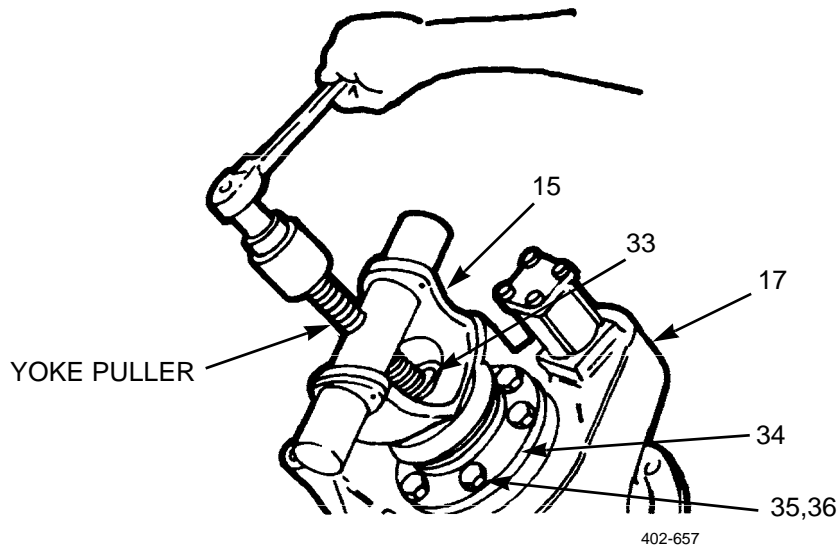



**DIFFERENTIAL CARRIER DISASSEMBLY - CONTINUED****NOTE**

In step (3), as the input shaft is pressed through the gear cover and the interaxle differential shift collar inside the cover, the collar will drop from the shift fork and shaft. Also, the input bearing will remain loose in the cover. If seal and/or bearing removal is necessary, continue with step (4).

- (3) Using a press, remove the input shaft (33) from the gear cover (17). Press out shaft from the front (input end).
- (4) Disassemble the input bearing cover (34) from the gear cover (17) by removing cage-to-cover capscrews (35) and washers (36). Remove bearing cover, bearing (37), and shim pack (38). The bearing cup (39) will remain in the cover.
- (5) Remove the oil seal (40) from the bearing cover (34) using a press and suitable sleeve. If press is not available, use a drift and hammer and tap out seal.

**NOTE**

Keep the shim pack from under the bearing cover wired together for reassembly.

- (6) Remove the bearing cup (39) from the cover (34) by using a press or suitable puller.

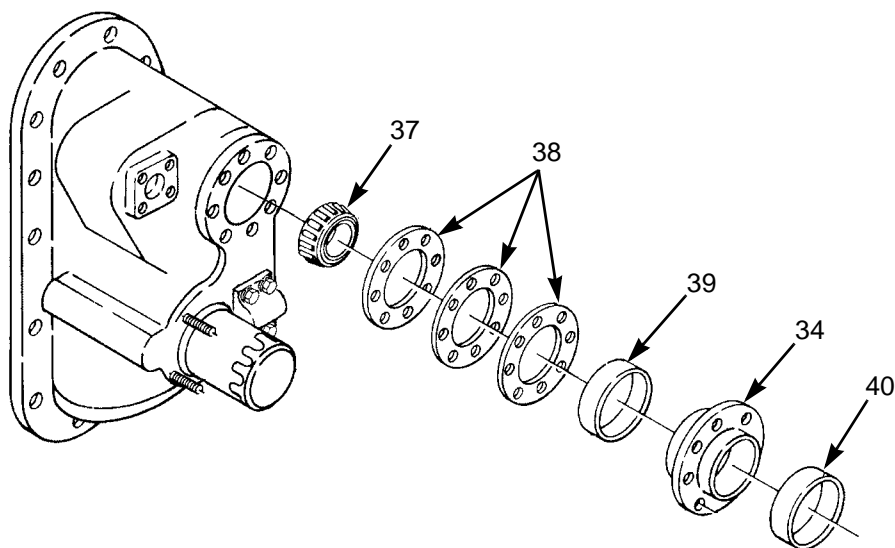

402-980A

**DIFFERENTIAL CARRIER DISASSEMBLY - CONTINUED**d. **Remove Shift Unit and Oil Pump Drive Gear.****NOTE**

To remove the oil pump drive gear and shaft assembly, it is necessary to first remove the shift unit components.

- (1) Using a screwdriver or other sharp-bladed tool: bend back the shift unit cover bolt retainer (45) ears. There is one retainer per bolt (41) with one ear bent against the bolt head and two ears bent against the top cover (42). Discard retainers.
- (2) Remove the four cover bolts (41) and pull the air chamber (44) with shaft (43) from its seat on the gear cover (17).

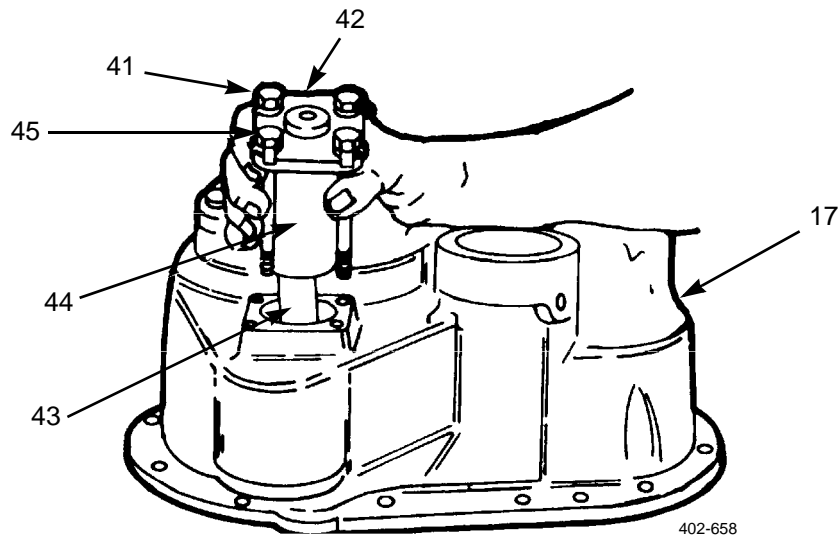

**DIFFERENTIAL CARRIER DISASSEMBLY - CONTINUED****NOTE**

The components within the air chamber are not serviceable as individual parts. If the air chamber is defective, the complete unit must be replaced.

- (3) Working from the inside of the gear cover (17), remove the shift fork (47) to shift shaft roll pin (48). Use a small diameter drift or punch and hammer to tap the pin out.
- (4) Remove the shift shaft (46), spring (49) and fork (47) from inside the gear cover by first pulling the shift shaft through the air chamber opening in the gear cover (17). The fork and spring will drop out after shaft removal.

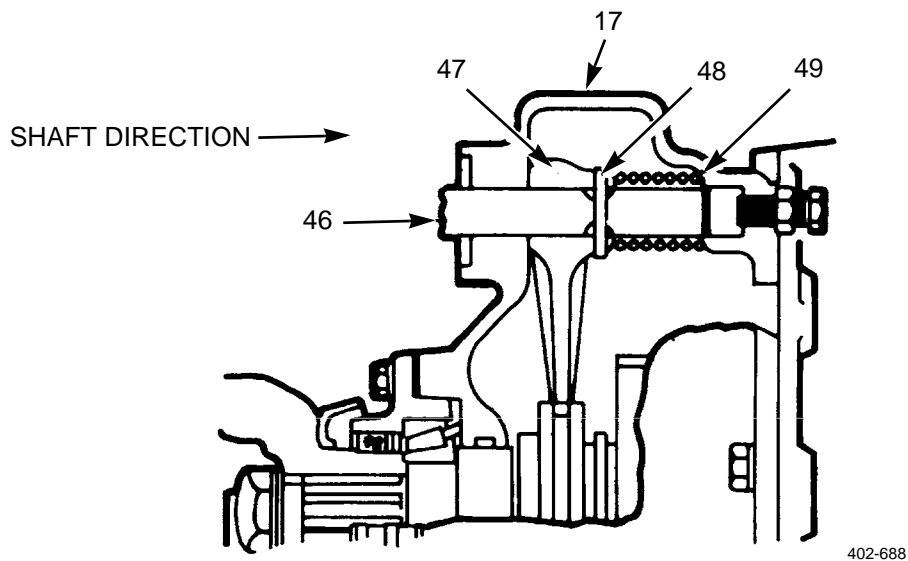

- (5) If desired, remove the shift shaft adjusting screw and jam nut from the gear cover (17).
- (6) Remove the oil pump drive gear (50) and shaft (53) from housing by removing lockring (52) and washer (51), then pull out gear and shaft from the helical gear cover.

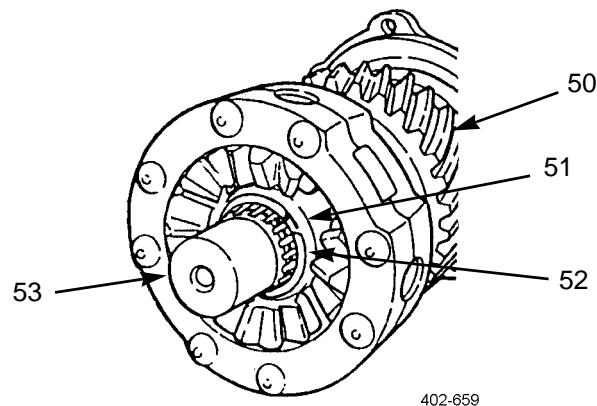

**DIFFERENTIAL CARRIER DISASSEMBLY - CONTINUED**e. **Disassemble Interaxle Differential.**

- (1) Remove the internal oil filter screen (58) from the carrier housing (59). If the screen is damaged in any way, discard it. Otherwise, set it aside for cleaning.
- (2) Lift off the interaxle differential forward side gear (55) and drive gear (54), as an assembly, and thrust washer (56) from the interaxle differential (57) located at top of the carrier (59).

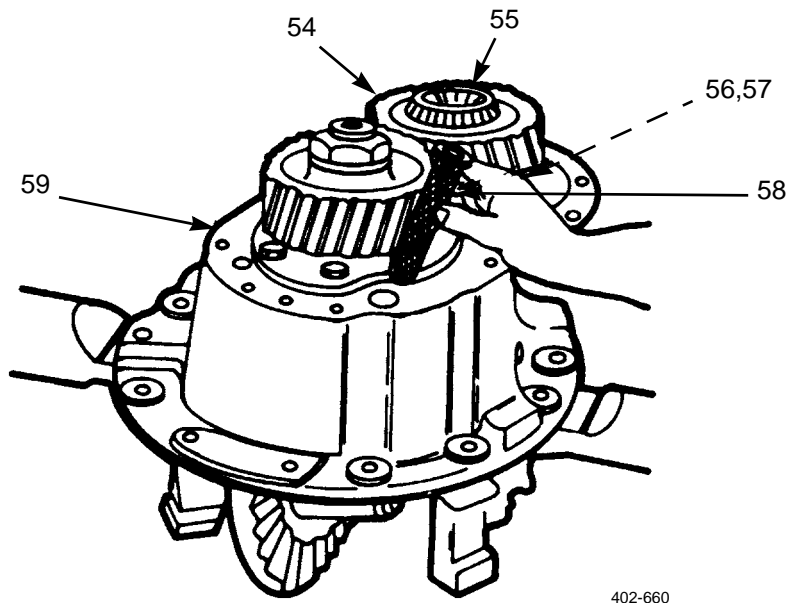
**CAUTION**

Do not press the side gear out by the gear teeth; damage to the teeth surfaces will occur.

- (3) Separate the interaxle forward side gear (55) from the helical drive gear (54). Place the assembly in a press and use a sleeve with an outer diameter that will fit the front hub portion of the side gear.
- (4) Remove woodruff key (60) from side gear (55).

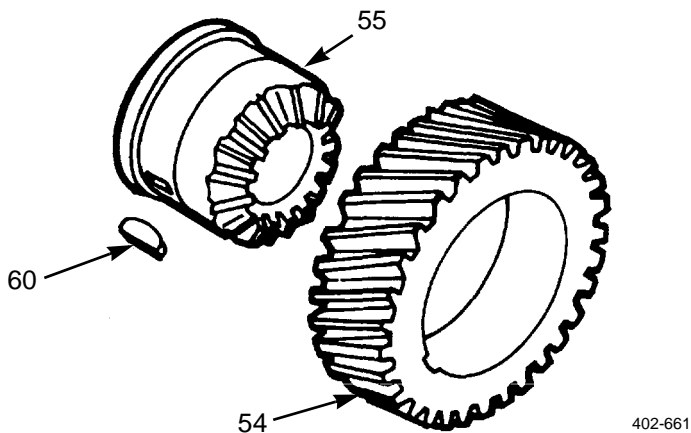

**DIFFERENTIAL CARRIER DISASSEMBLY - CONTINUED**

- (5) Lift out the interaxle differential (57) from the carrier housing (59).

**NOTE**

The rear side gear and rear input bearing will remain loose in the carrier housing. (Refer to step (8)).

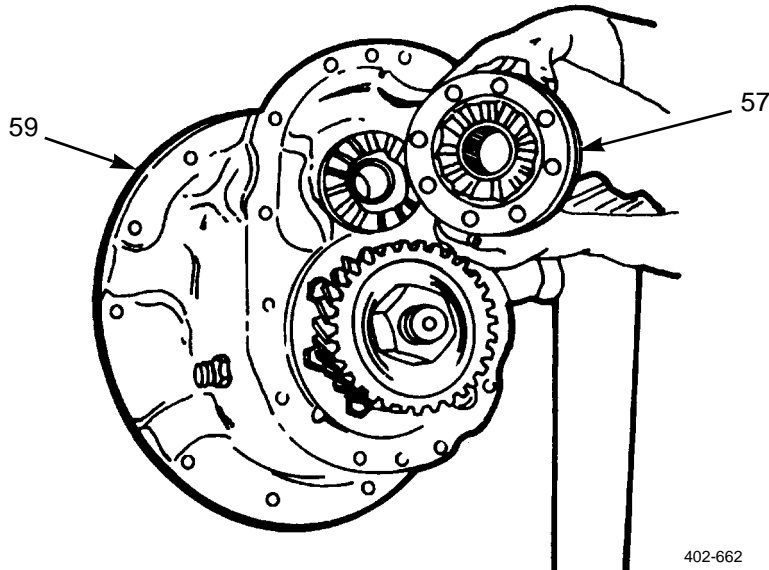

- (6) Match-mark the case halves (64 and 67) with a punch for correct alignment at reassembly.
- (7) Disassemble the case halves (64 and 67) by removing eight rivets (69). Remove the spider (68), four pinions (66), and thrust washers (65).
- (8) Lift out the rear side gear (63) and bearing cone (62) from the carrier (59). The bearing cup (61) will remain in the carrier. If replacement is necessary, remove the cup using a suitable bearing puller.
- (9) To remove the bearing cone (62) from the rear side gear (63), place the gear in a press. Use a suitable sleeve and press the gear from the bearing cone. If a press is not available, use a suitable bearing puller.

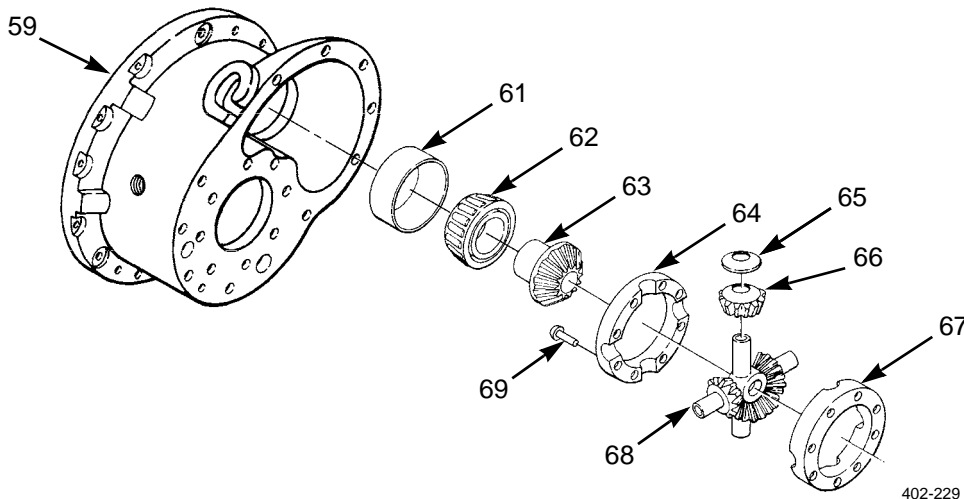

**DIFFERENTIAL CARRIER DISASSEMBLY - CONTINUED**f. **Remove Main Differential and Ring Gear Assembly.**

- (1) With the carrier (59) still in an upright position, loosen the jam nut (79) and back off the ring gear thrust screw (78).
- (2) Rotate the carrier (59) 180° and bring the ring gear (77) to an upright position.
- (3) Check and record the backlash. This information will be needed in reassembly unless a new gear set is used.
- (4) Center punch one differential carrier (59) leg and bearing cap (72) to identify for reassembly.
- (5) Remove the carrier cap capscrews (70), washers (71), and cotter pins (73) from both sides of the carrier. Discard cotter pins.
- (6) Remove the bearing adjusting rings (74) and the carrier caps (72).
- (7) Remove cups (75) from ring gear assembly (77).
- (8) Lift out the differential and ring gear assembly (77).

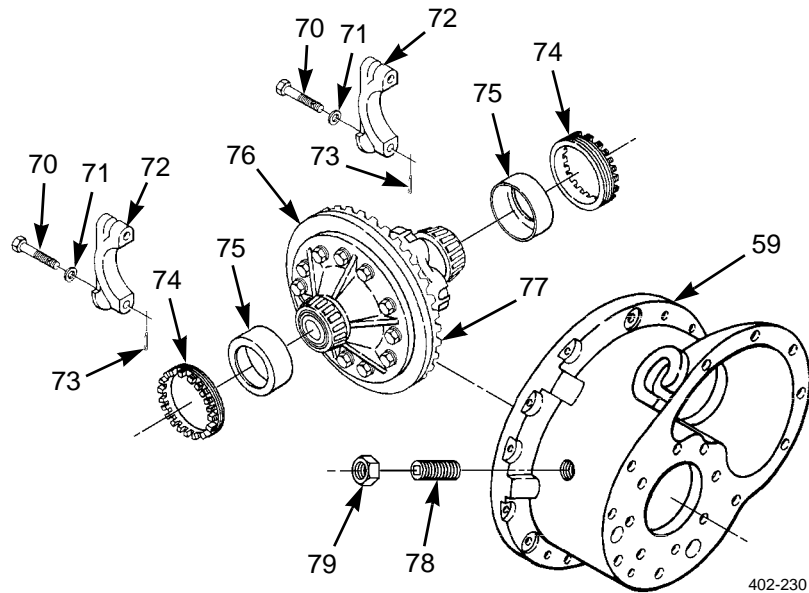

**DIFFERENTIAL CARRIER DISASSEMBLY - CONTINUED**

g. **Disassemble Main Differential and Ring Gear Assembly.**

- (1) If original identification marks are not clear, mark the differential case halves with a punch or chisel for correct alignment on reassembly.

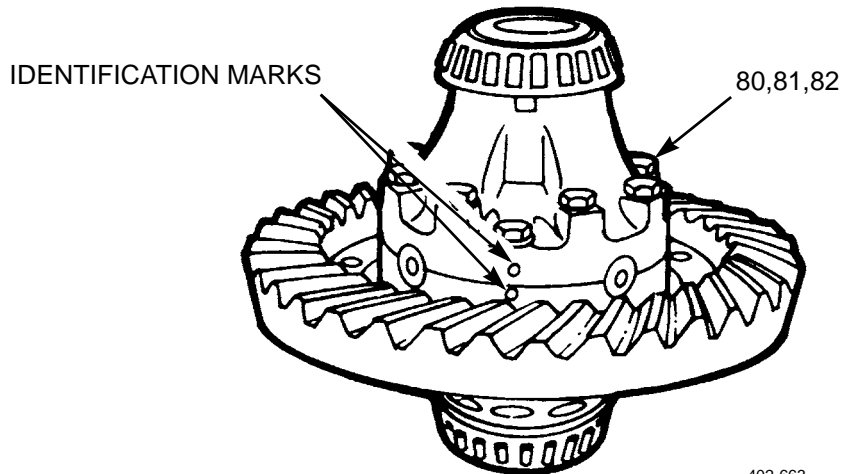

402-663

- (2) Remove the lockwire (if used), capscrews (80), washers (81), and nuts (82). Separate the case halves.
- (3) Remove the spider (88) assembly.
- (4) Remove two side gears (83), two spring retainers (84), two springs (85) and two driven clutches (86) with holdout ring (87) assemblies from spider (88) assembly.

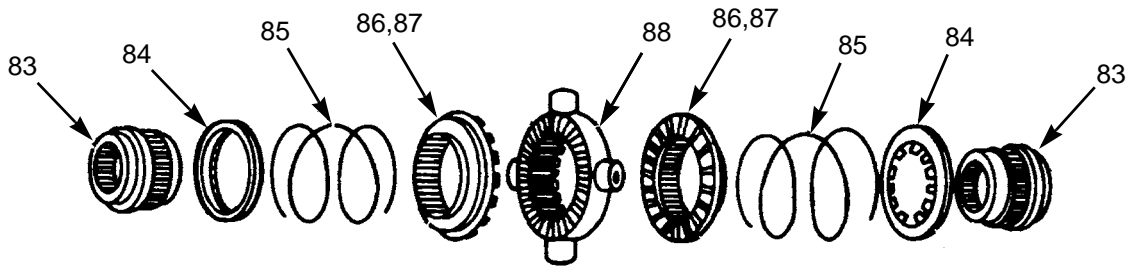

402-664

- (5) If ring gear is to be replaced for any reason, remove rivets and separate the gear from the case, as follows:
  - (a) Carefully center-punch rivets in center of the head.
  - (b) Use a drill 1/32-inch smaller than body of rivet to drill through rivet head from gear side.
  - (c) Punch out the rivets.
  - (d) If necessary to replace differential bearings, remove with a suitable puller.

**DIFFERENTIAL CARRIER DISASSEMBLY - CONTINUED****h. Remove Pinion Shaft and Cage Assembly.**

- (1) Loosen the pinion cage capscrews (101) until the heads contact the back (under) face of the helical driven gear (98). Continue loosening the capscrews approximately three turns each, alternating with the other capscrews. This will avoid cocking the bearing cage (95) in the carrier (59) while the capscrews act as puller screws.
- (2) Continue loosening the capscrews (101) until the cage (95), capscrews (102), and washers (101) are removed. Remove the shims (94) from under the bearing cage and wire together for reassembly.

**CAUTION**

It may be necessary to tap out the pinion and bearing cage assembly by using a brass bar and hammer on the pinion shaft end. Care should be exercised not to damage the bearing. In either case, the bearing will remain on the pinion.

- (3) Remove pinion nut (100) and washer (99).
- (4) Press pinion shaft (90) out from bearing cage (95), bearings (91 and 97) and driven gear (98).
- (5) Remove outer bearing (97) from bearing cage (95) and bearing spacer (93) from pinion shaft (90).
- (6) If necessary, remove the pinion inner bearing (91) and bearing (89) with a suitable puller.
- (7) If necessary, replace pinion bearing cups (92 and 96), remove with a suitable puller (if cups are in good condition, do not remove).

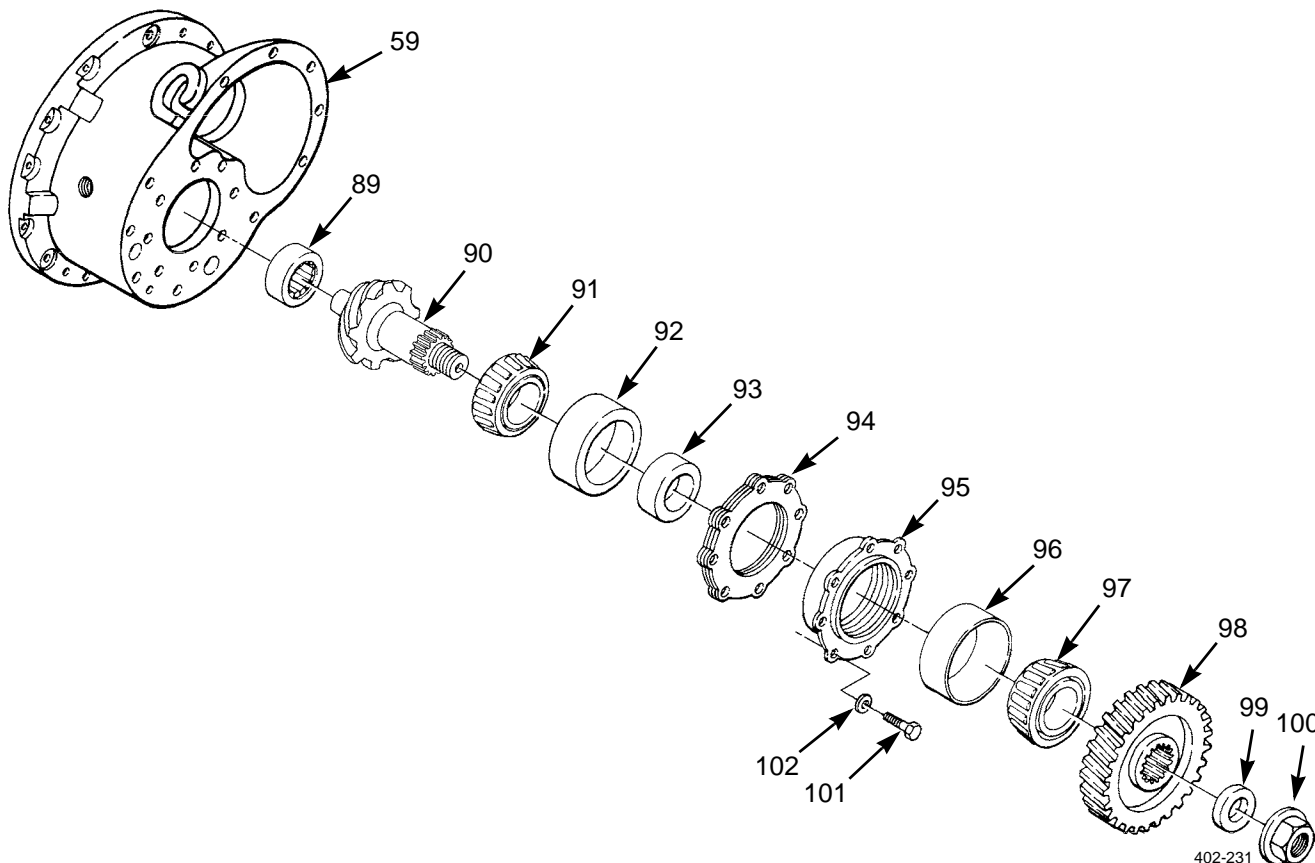



**CLEANING**a. **Ground or Polished Surface Parts.****WARNING**

Exercise care to avoid skin rashes, fire hazards, and inhalation of vapors when using solvent-type cleaners.

**CAUTION**

Do not use gasoline. Do not clean these parts in a hot solution tank or with water and alkaline solutions, such as sodium hydroxide, orthosilicates, or phosphates. Do not steam clean assembled drive units after they have been removed from the housing. When this method of cleaning is used, water is trapped in the cored passage of the castings and in the close clearances between parts as well as on the parts. This can lead to corrosion (rust) of critical parts of the assembly and the possibility of circulating rust particles in the lubricant. Premature failure of bearings, gears and other parts can be caused by this practice. Assembled drive units cannot be properly cleaned by steam cleaning, dipping or slushing. Complete drive unit disassembly is a necessary requisite to thorough cleaning.

- (1) Parts having ground and polished surfaces, such as gears, bearings, shafts and collars, should be cleaned in detergent (Item 18, WP 0312 00).
- (2) Clean all mating surfaces where fiber or liquid gasket material is used. It may be necessary to use a scraper to completely remove gasket materials. Be careful, not to damage mating surfaces.

b. **Rough Parts.****WARNING**

Exercise care to avoid skin rashes and inhalation of vapors when using alkali cleaners.

Rough parts, such as differential carrier castings, cast brackets, and some brake parts may be cleaned in hot solution tanks with mild alkali solution detergent (Item 18, WP 0312 00) providing these parts are not ground or polished. The parts should remain in the tank long enough to be thoroughly cleaned and heated through. This will aid the evaporation of the rinse water. The parts should be thoroughly rinsed after cleaning to remove all traces of alkali. If this solution is not available, dry cleaning solvent may be used.

- c. **Complete Assemblies.** Completely assembled axles may be steam cleaned on the outside only, to facilitate initial removal and disassembly, provided all openings are closed. Breathers, vented shift units, and all other openings should be tightly covered or closed to prevent the possibility of water entering the assembly.
- d. **Drying.** Parts should be thoroughly dried immediately after cleaning. Use soft, clean, lintless absorbent paper towels or wiping rags free of abrasive material, such as lapping compound, metal filings or contaminated oil. Bearings should never be dried by spinning with compressed air.
- e. **Corrosion Prevention.** Parts that have been cleaned, dried, inspected, and are to be immediately reassembled should be coated with light oil to prevent corrosion. If these parts are to be stored for any length of time, they should be treated with a good *rust preventive* and wrapped in special paper or other material designed to prevent corrosion.

**INSPECTION**

- a. **Tapered Roller Bearings.** Inspect all bearings, cups and cones, including those not removed from parts of the drive unit, and replace if rollers or cups are worn, pitted or damaged in any way. Remove parts needing replacement with a suitable puller or in a press with sleeves. Avoid the use of drifts and hammers. They may easily mutilate or distort component parts. If any of the following bearing conditions exist, the bearings must be replaced:
  - (1) Large ends of rollers worn flush to recess, or radii at large ends of rollers worn sharp.
  - (2) Visible step wear, particularly at the small end of the roller track.
  - (3) Deep indentations, cracks or breaks in bearing cup and/or cone surfaces.
  - (4) Bright rubbing marks on the dark phosphate surfaces of the bearing cage.
  - (5) Etching or pitting on functioning surfaces.
  - (6) Spalling or flaking on bearing cup and/or cone surfaces.
- b. **Drive Pinion Gear and Ring Gear.** Inspect the pinion shaft and ring gear for wear or damage. Gears which are worn, ridged, pitted, or scored should be replaced. When necessary to replace either the pinion shaft or ring gear of a set, the entire gear set must be replaced.
- c. **Differential Gears.** Inspect the differential assembly for the following.
  - (1) Check for pitted, scored or worn thrust surfaces of differential case halves, thrust washers, spider trunnions, and differential gears. Thrust washers must be replaced in sets. The use of a combination of old and new washers will result in premature failure.
  - (2) Inspect for wear or damage to the differential pinion and side gear teeth. Always replace differential pinions and side gears in sets.
- d. **Helical Gears.** Inspect helical gears for wear or damage. Gears which are worn, ridged, pitted or scored, should be replaced. Helical gears must be replaced in sets. New helical gears in sets must be permanently marked with matching or timing symbols to aid in correctly positioning the teeth of both gears at reassembly.

**REPAIR OR REPLACEMENT**

- a. **General.**
  - (1) Replace all worn or damaged parts. Hexnuts with rounded corners, all lockwashers, oil seals and gaskets or silicone gasket material should be replaced at the time of overhaul.
  - (2) Remove nicks, mars, and burrs from machined or ground surfaces. Threads must be clean and free to obtain accurate adjustment and correct torque. Studs must be tight prior to reassembling the parts.
  - (3) When assembling component parts, use a press where possible.
- b. **Silastic Application.**
  - (1) Removal of all gaskets including silicone is accomplished by peeling or scraping the used gasket off the carrier-to-housing surfaces.

**REPAIR OR REPLACEMENT - CONTINUED**

- (2) Application of silastic is as follows:
  - (a) Remove dirt, grease or moisture from the surface of the carrier and housing.
  - (b) Dry the surface.
  - (c) Apply thin bead, approximately 1/8-inch diameter completely around one mating surface and all fastener holes to assure complete sealing and prevent leakage.

**WARNING**

- Minor concentrations of acetic acid vapor may be produced during application.
  - Adequate ventilation should be provided when silicone is applied in confined areas. Further, eye contact may cause irritation.
  - If eye contact takes place, flush eyes with water for 15 minutes and have eyes examined by a doctor.
- (d) Assemble the components immediately to permit silastic to spread evenly.

**c. Wear Sleeve Replacement.**

- (1) Place the yoke on its side in a vise.

**CAUTION**

Do not completely split or penetrate the sleeve bushing and damage the yoke.

- (2) Using a cold chisel, notch the wear sleeve slightly to expand the sleeve bushing and permit its removal from the yoke.

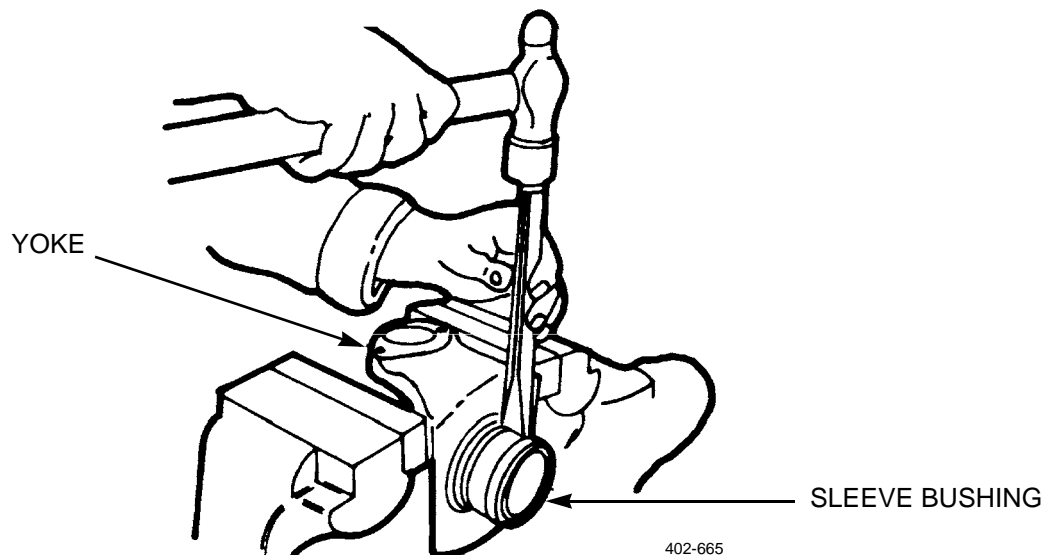

**REPAIR OR REPLACEMENT - CONTINUED**

- (3) Remove the sleeve bushing.

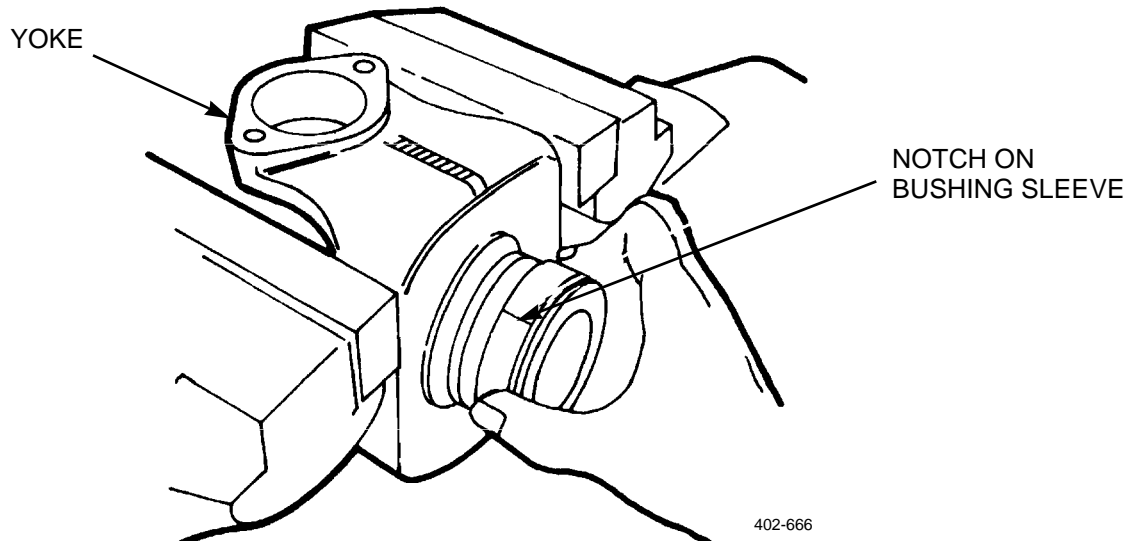

- (4) If unsuccessful, notch the sleeve bushing in the same location again

**NOTE**

Do not split the sleeve bushing.

- (5) Remove the sleeve bushing.
- (6) If unsuccessful, rotate the yoke 180°, notch slightly again, and remove sleeve bushing.

**NOTE**

Replacement of the sleeve bushing requires sleeve bushing driver.

- (7) Grease the o-ring inside the tool with bearing grease (Item 23, WP 0312 00) to facilitate sliding new sleeve bushing into the tool.

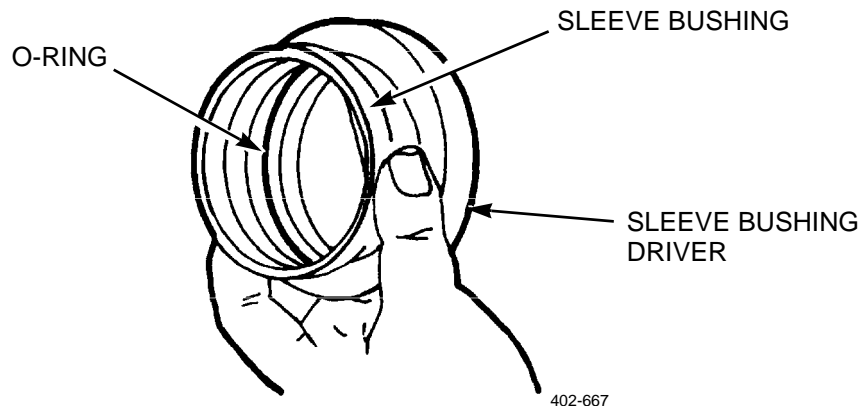

**REPAIR OR REPLACEMENT - CONTINUED**

- (8) Position the driver and sleeve bushing into the tool cavity, tapered end first.
- (9) Place the driver and sleeve bushing squarely against the hub end of the yoke.

**CAUTION**

Do not install the sleeve bushing by striking the driver, as this practice may cause excessive expansion of the sleeve bushing and will permit the sleeve bushing to rotate on the yoke.

- (10) Employing a small mechanical press, place the driver, sleeve bushing and yoke into the press.

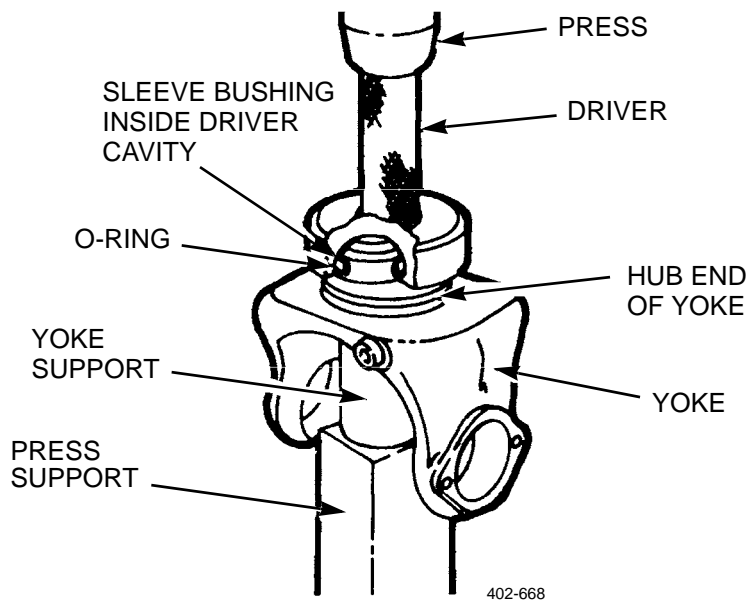

- (11) Activate the press, forcing the driver to push the sleeve bushing onto the yoke until it bottoms.

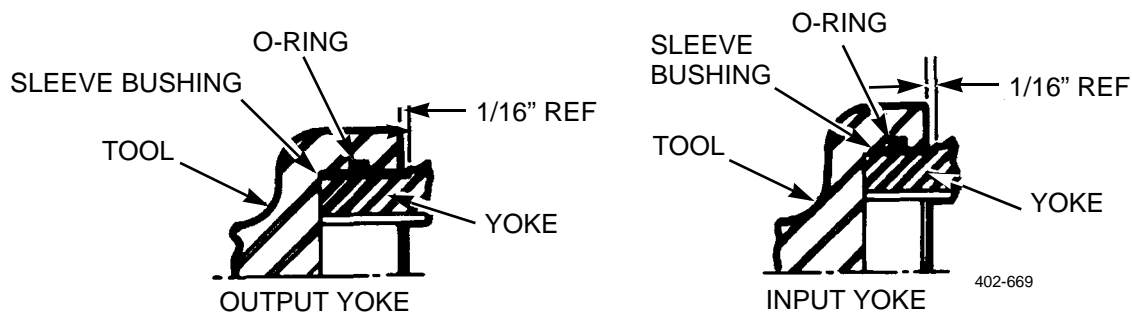

- (12) When removing the driver, pull the driver straight off. Do not work the driver in a circular or alternately back-and-forth motion, as this may damage the sleeve bushing surface.
- (13) Examine the sleeve bushing after installation for nicks or burrs that may cut or wear the seal. These may be removed by careful filing.

**DIFFERENTIAL CARRIER ASSEMBLY****CAUTION**

Pinion gear and ring gear are a matched set and have a common number etched on each. Before assembly, check numbers.

a. **Assemble Pinion Shaft and Cage Assembly.****NOTE**

Before assembling, coat all parts of bearings with recommended axle lubricant (Item 33, WP 0312 00).

- (1) Press rear bearing firmly against the pinion shaft (90) shoulder with a suitable sleeve against the bearing inner race.
- (2) Press the bearing (89) into position on the pinion end.
- (3) To retain the bearing (89) on the pinion end, it is necessary to stake the pinion shaft (90) at three points. Use the proper staking tool to fit over the end of the pinion and bearing to correctly achieve this.

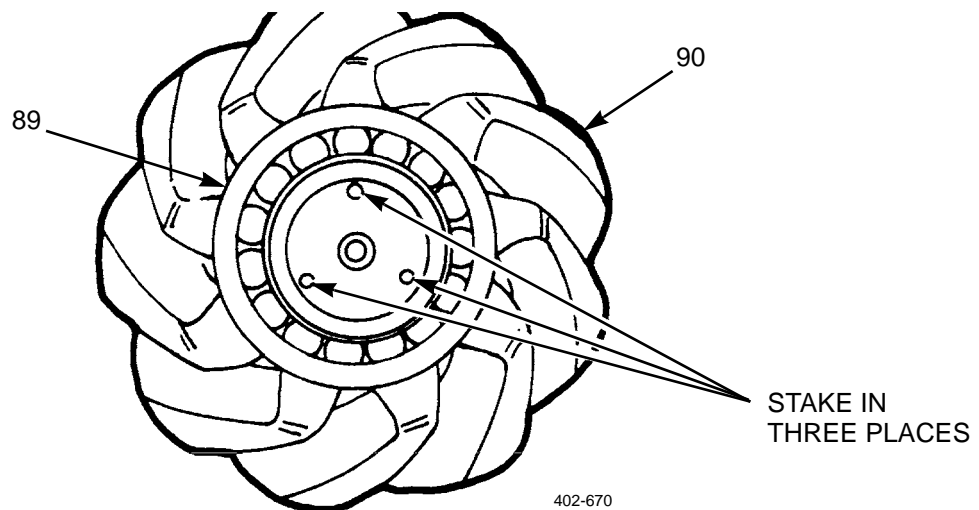
**CAUTION**

Do not strike the bearing or attempt to stake bearing onto pinion shaft using a punch and hammer – damage will result. Staking points are not to be spotted at the root angle grooves of the pinion (if present) or in the original staking points if using the original bearing.

- (4) Position the pinion shaft (90) with bearing (89) pointing upward in a press and place the staking tool over the pinion end and bearing. Apply a 3.5 ton pressure to the staking tool.

**DIFFERENTIAL CARRIER ASSEMBLY**

- (5) If new cups (92 and 96) are to be installed, press the cups into bearing cage (95) using suitable sleeve. Make sure the cups are firmly against the cage shoulders.
- (6) Insert the pinion shaft (90), bearing assembly (91), and bearing assembly (97) in the bearing cage (95) and position the spacer (93) over the pinion shaft.
- (7) Press the forward bearing (97) firmly against the spacer (93).
- (8) Rotate the bearing cage (95) several revolutions to assure normal bearing contact.
- (9) While in the press under pressure, check the bearing preload torque. Wrap a soft wire around the cage pilot and pull on a horizontal line with a pound scale. (If the press is not equipped with a pressure gage, the pinion nut may be tightened to the correct torque and the preload checked in a vise).

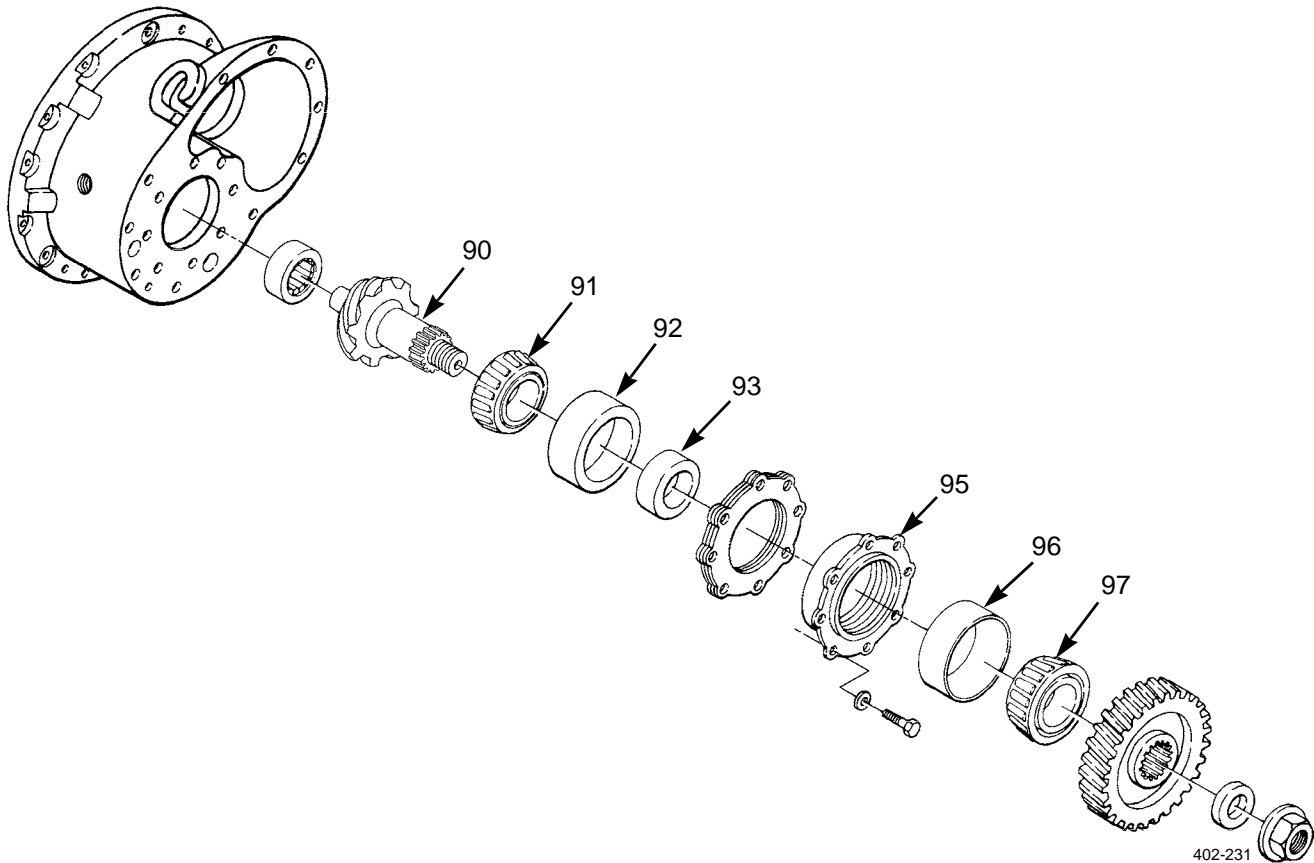

**DIFFERENTIAL CARRIER ASSEMBLY**

**NOTE**

For new pinion bearings, the rotating torque must be within 5-25 lb-in. For reused pinion bearings, the rotating torque must be within 5-15 lb-in.

- (10) If the rotating torque is not within these values, use a thinner spacer (93) to increase, or a thicker spacer to decrease the preload torque. The correct pressure and nut (100) torque for checking pinion bearing preload are as follows:

<b>Pinion Shaft Thread Size</b>	<b>Required Nut Torque To Obtain Correct Preload</b>	<b>Required Pressure To Obtain Correct Preload</b>
1-3/4x 12	900-1200 lb-ft (1220-1627 Nm)	11-14 tons (10-12.7 metric tons)

- (11) Insert pinion cage to carrier capscrews (101) and washers (102) in their respective holes in the bearing cage (95).

**NOTE**

If the helical driven gear must be replaced with a new gear, replace both the drive and driven gears as a set.

- (12) Press the drive pinion helical gear (98) against the forward bearing (97) and install washer (99) and pinion shaft nut (100).
- (13) Using a suitable holder on gear (98), tighten the pinion shaft nut (100) to the required torque.
- (14) Recheck pinion bearing preload torque. If rotating torque is not within specified values, repeat the foregoing procedure.
- (15) If the original gears are reused, install the original shim pack. If gears have been replaced, alter the original shim pack as follows: Note the variation from the nominal assembly dimension on both the old and new pinion. (The nominal dimension is stamped and the variation is etched on the nose of the pinion.) Increase or reduce the shim (94) pack in accordance with the change in the variation from the old to the new pinion. After changing the sign of the old variation – plus-to-minus or minus-to-plus – add to the new variation (sign unchanged).
- (16) Position the pinion shaft and cage assembly in the carrier (59) and tap into place with a soft mallet. Make certain that capscrews (101) are aligned with respective holes in carrier, and that bearing cage (95) is not cocked in its bore.
- (17) Start turning in pinion cage capscrews (101) approximately three turns each and alternating with other capscrews. This will avoid cocking the bearing cage (95) in the carrier while the capscrews push the cage into position. When the cage is seated in the carrier loosen the capscrews and then retighten to torque of 80-105 lb-ft (108-142 Nm).



**DIFFERENTIAL CARRIER ASSEMBLY**

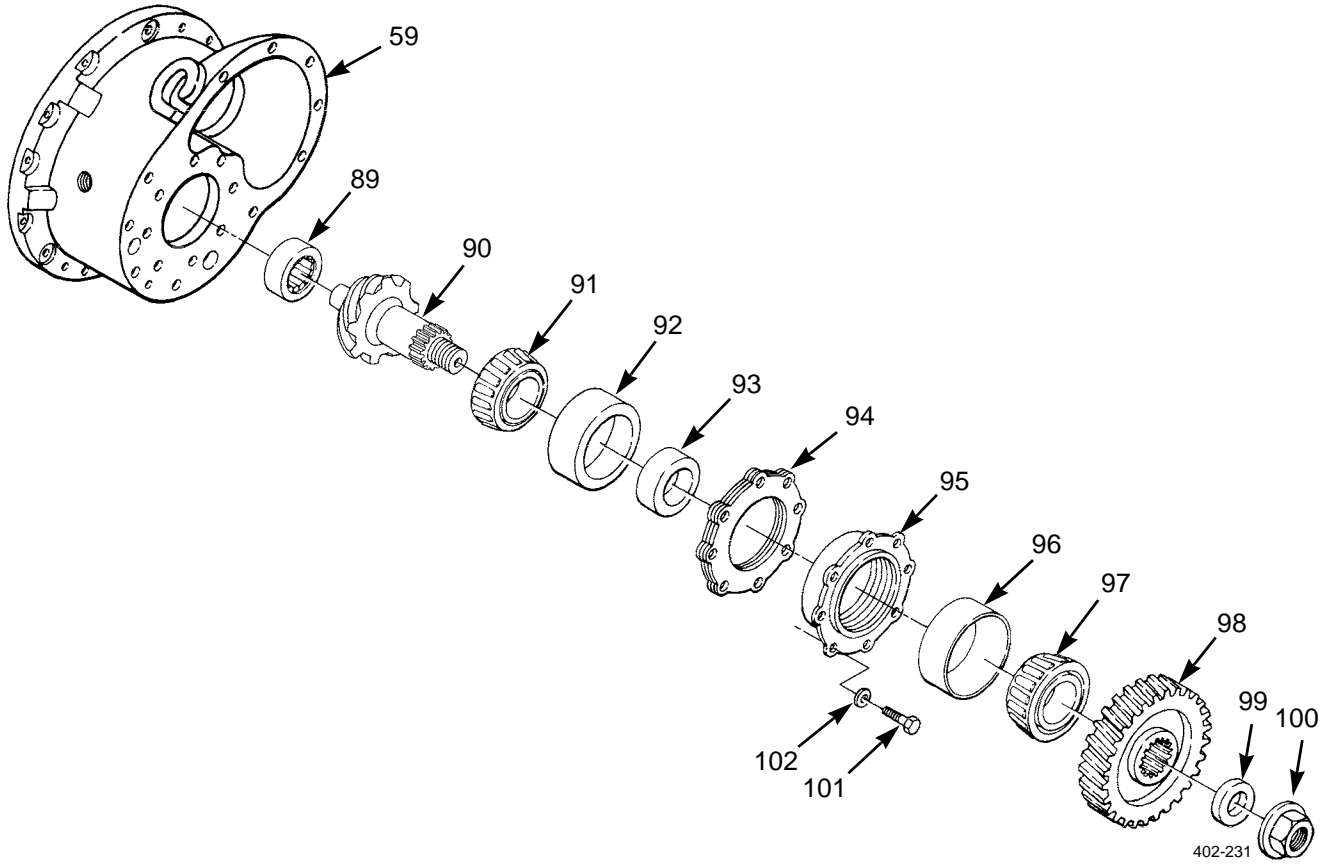

**DIFFERENTIAL CARRIER ASSEMBLY - CONTINUED**

- b. Assemble the Main Differential and Ring Gear Assembly.

**CAUTION**

The ring gear should not be pressed or driven on the case, as this would cause excessive metal particles to lodge between the gear and the case, thus resulting in gear run-out. Proper installation should, therefore, incorporate preheating the gear to assure correct interference fit and to eliminate metal pick up.

- (1) Heat the ring gear (77) in oil to approximately 1600°F-1800°F (71.1°C-82.2°C) for about ten minutes before assembly.
- (2) If ring gear (77) has been separated from case (76), fasten with 12 bolts (80), washers (81), and nuts (82). Torque to 180-230 lb-ft (244-312 Nm).

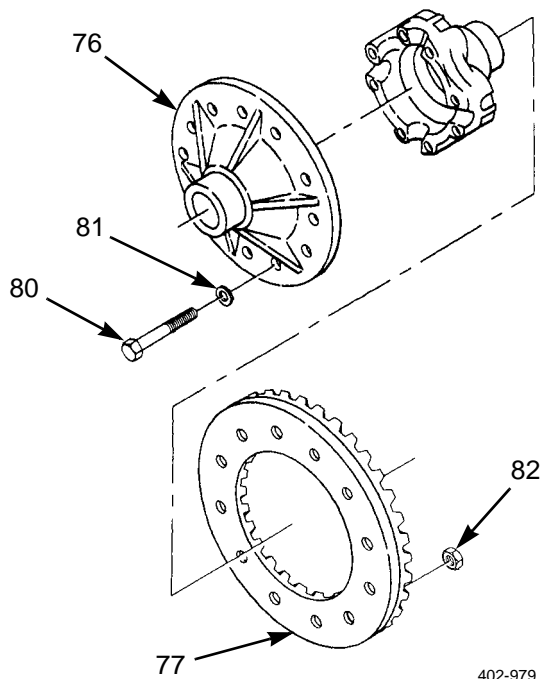

- (3) Assemble and install spider (88) assembly as follows.
  - (a) Lightly lubricate all parts with recommended gear case lubricant (Item 33, WP 0312 00).
  - (b) Lay ring gear and large half of case on bench with the bearing end of case (76) hub down and the inner case facing upward. Be sure no thrust washers are inside the case.

**DIFFERENTIAL CARRIER ASSEMBLY - CONTINUED**

- (c) Place the ground hub of a side gear (83) into the bore of the case (76), being sure the side gear will rotate freely in the case.
- (d) Assemble a spring retainer (84) over the side gear (83) splines, with the side gear flange firmly seated into the cupped section of the retainer. Make sure this part is installed correctly. Incorrect assembly of the spring retainer can limit the spring movement and prevent proper spider (88) assembly operation.

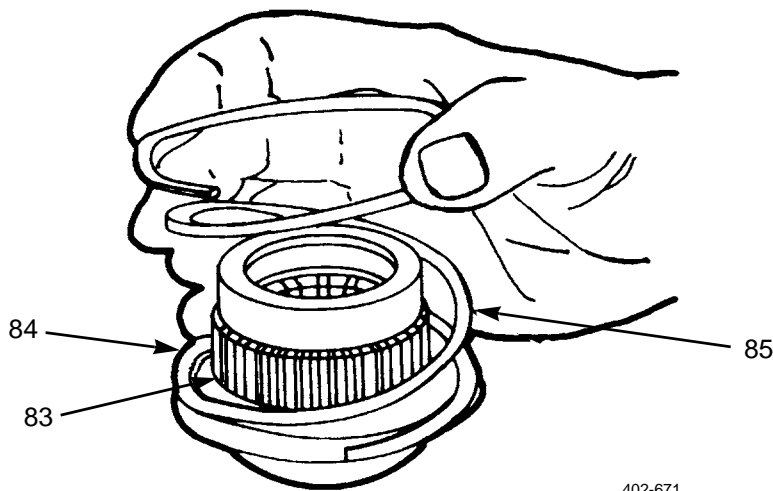

- (e) Place a spring (85) over the side gear (83) inner hub and splines and against the spring retainer (84) seat. Some models have tapered, conically-shaped springs and the end with the smaller diameter should fit against the spring retainer.
- (f) Assemble the clutch (86) (or the clutch and holdout ring (87) assembly if silent-type) over the spring with the clutch teeth up. Check to see if spring is functioning freely by compressing clutch over the side gear splines.

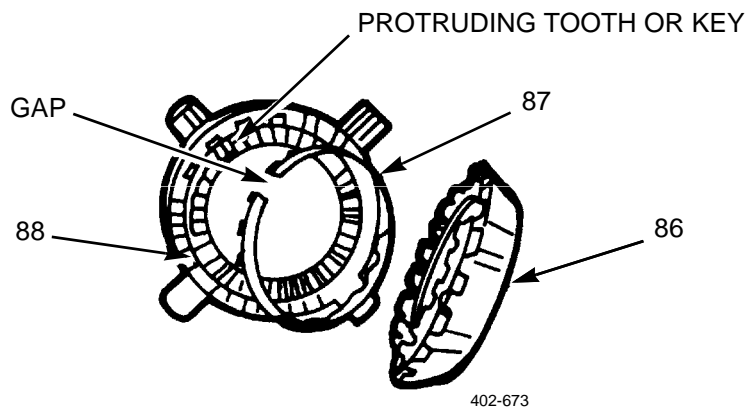

**DIFFERENTIAL CARRIER ASSEMBLY - CONTINUED**

- (g) Check to see that spring (85) is not binding and coils do not overlap and there is good contact between the end coil and the spring retainer when the clutch and side gear splines are fully indexed.

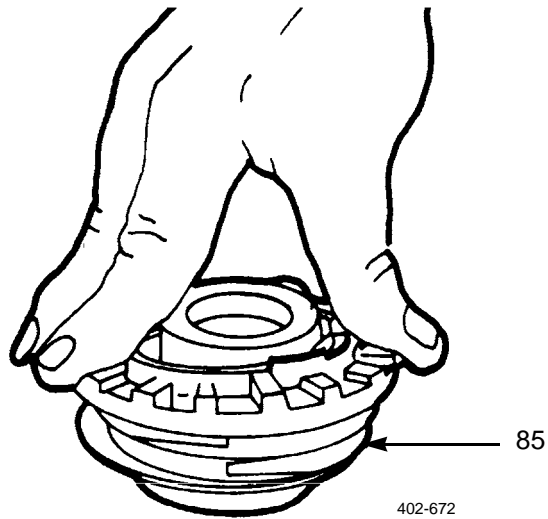

- (h) Place spider (88) on the driven clutch (86), indexing the teeth. Make sure slot in the holdout-ring (87) and spider-key are properly mated.

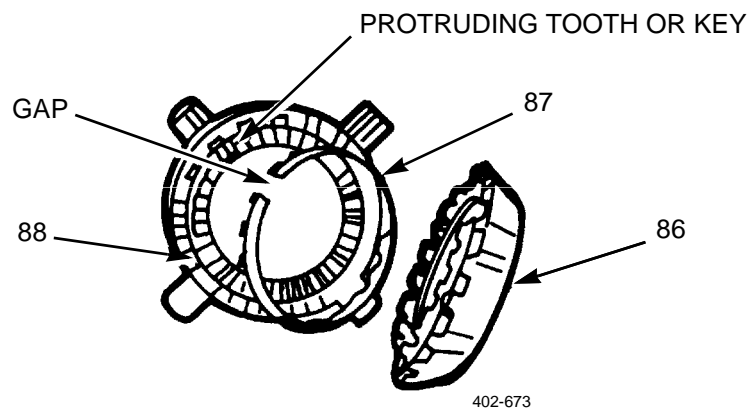

**DIFFERENTIAL CARRIER ASSEMBLY - CONTINUED**

- (i) Place the other clutch holdout-ring (87) assembly on the spider (88) again, indexing the teeth, and being sure again that the spider-key and holdout-ring slot are properly aligned. Assemble the spring (85) over the clutch with larger diameter of spring against the clutch.
- (j) Place the other spring (84) retainer over the other side gear splines (cup section up with the retainer firmly seated against the side gear flange), and assemble the spring retainer and side gear over the spring.
- (k) Mount the mating half of the case (76) over the side gear (83) and compress unit. Be sure the side gear splines are completely indexed with the clutch splines.

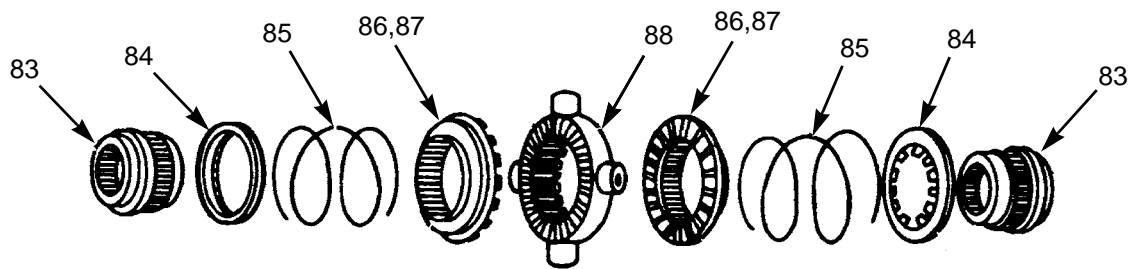

402-664

- (l) Hold the case (76) halves together firmly, aligning the punch marks to be sure the two case halves are properly mated. Start threading some of the case bolts but do not release hand pressure until two or more bolts are drawn up enough to overcome the spring pressure.

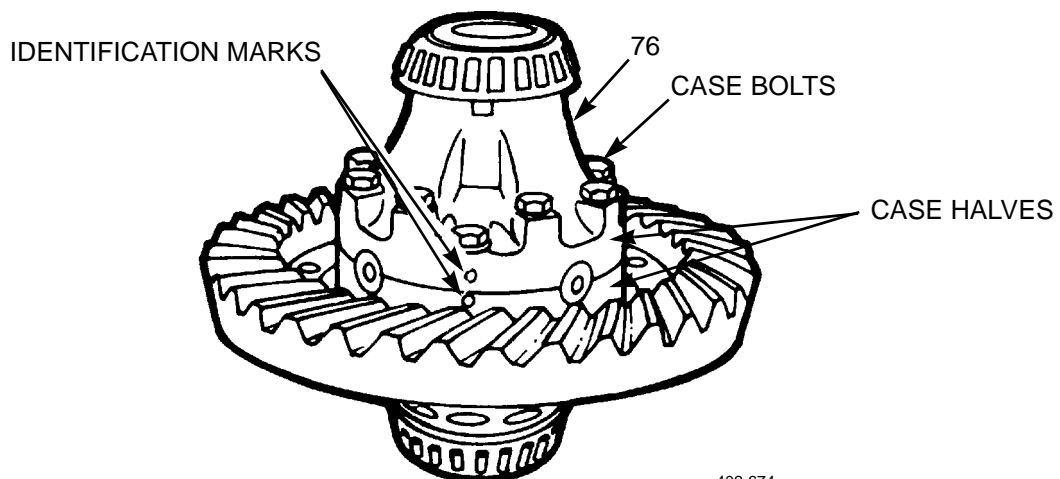

402-674

- (m) Tighten case bolts to a torque of 85-115 lb-ft (115-156 Nm). Check to be certain of a snug fit between the two case halves at all points and between the holes in case and the spider trunnions.
- (4) If roller bearings and bearing cones have been removed, press cone onto each end of assembly using a suitable sleeve.

**DIFFERENTIAL CARRIER ASSEMBLY - CONTINUED**c. **Install Main Differential and Ring Gear Assembly.**

- (1) Pre-lubricate differential bearings and cups with the recommended axle lubricant.
- (2) Place cups (75) over bearings and position differential ring gear assembly (76) in carrier housing (59).
- (3) Insert the bearing adjusting nuts (74) and turn hand tight against bearing cups (75).

**CAUTION**

In step (4), if the bearing caps do not position properly, adjusting nuts might be cross-threaded. Remove caps and reposition the adjusting nuts. Forcing caps into position will result in irreparable damage to the carrier housing or bearing caps.

- (4) Install the bearing caps (72) in the correct location as marked and tap lightly into position.
- (5) Install the washers (71) and capscrews (70) and torque to 290-350 lb-ft (393-475 Nm).

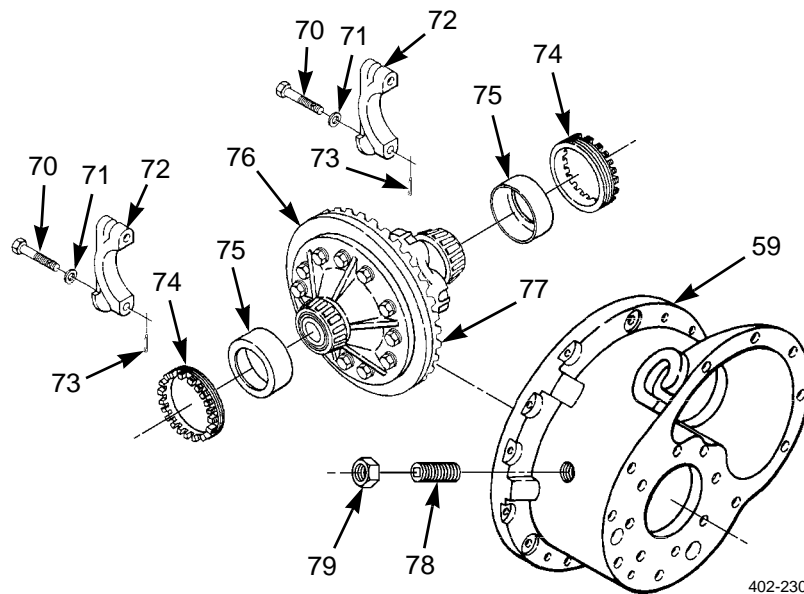

- (6) Adjust the adjusting nuts (74) as follows: (Cotter pins (73) will be installed after final adjustments are made).

**DIFFERENTIAL CARRIER ASSEMBLY - CONTINUED**d. **Adjust the Differential Bearing Preload.**

- (1) Using a dial indicator at the back face of the ring gear (77), loosen the bearing adjusting ring (74) on the side opposite gear only enough to notice end play on the indicator.

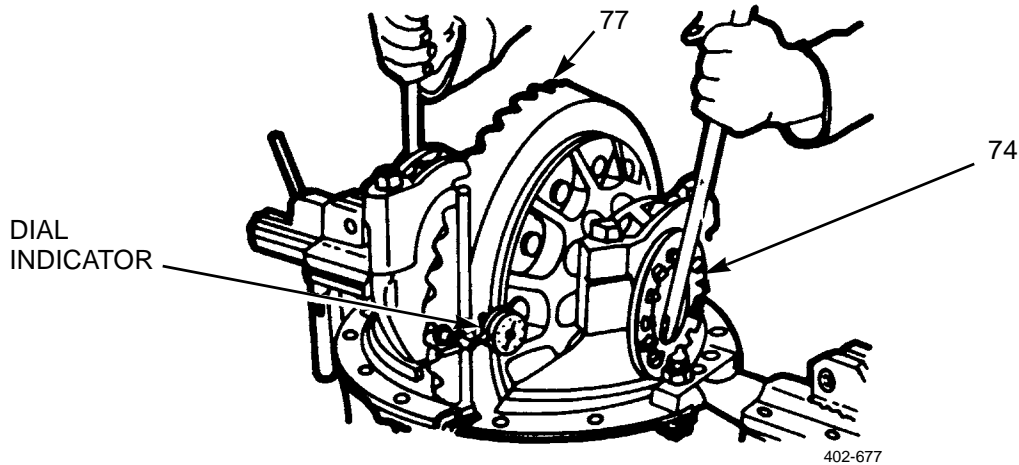

- (2) Tighten the same adjusting ring (74) only enough to obtain 0.000 end play.
  - (3) Check the ring gear (77) for run-out. If run-out exceeds 0.008 in. (0.203 mm), remove the differential and check for cause.
  - (4) Starting with 0.000 end play, tighten each adjusting ring (74) one notch. This will properly preload the differential bearings.
- e. **Check Hypoid Gear Backlash.** If the ring gear (77) is not going to be replaced, the established backlash recorded before disassembly should be used. For new ring gears the new backlash should be initially set at 0.010 in. (0.254 mm). Adjust backlash by moving the ring gear only. This is done by backing off one adjusting ring (74) and advancing the opposite ring the same amount.

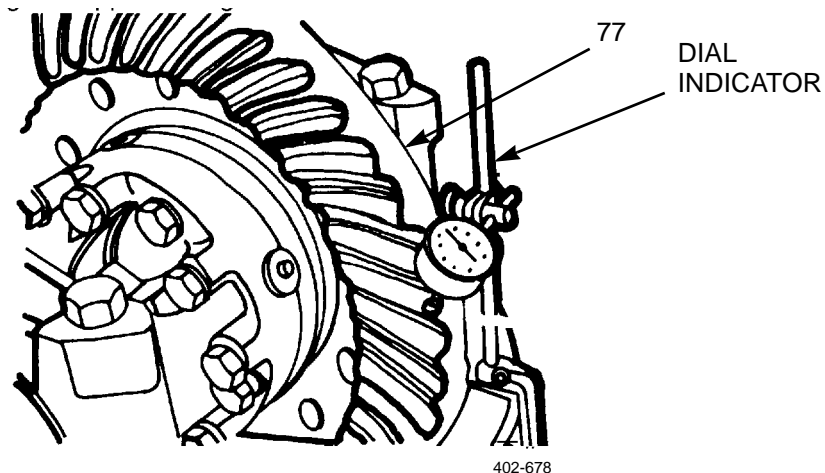

**DIFFERENTIAL CARRIER ASSEMBLY - CONTINUED**

f. **Check Tool Contact.**

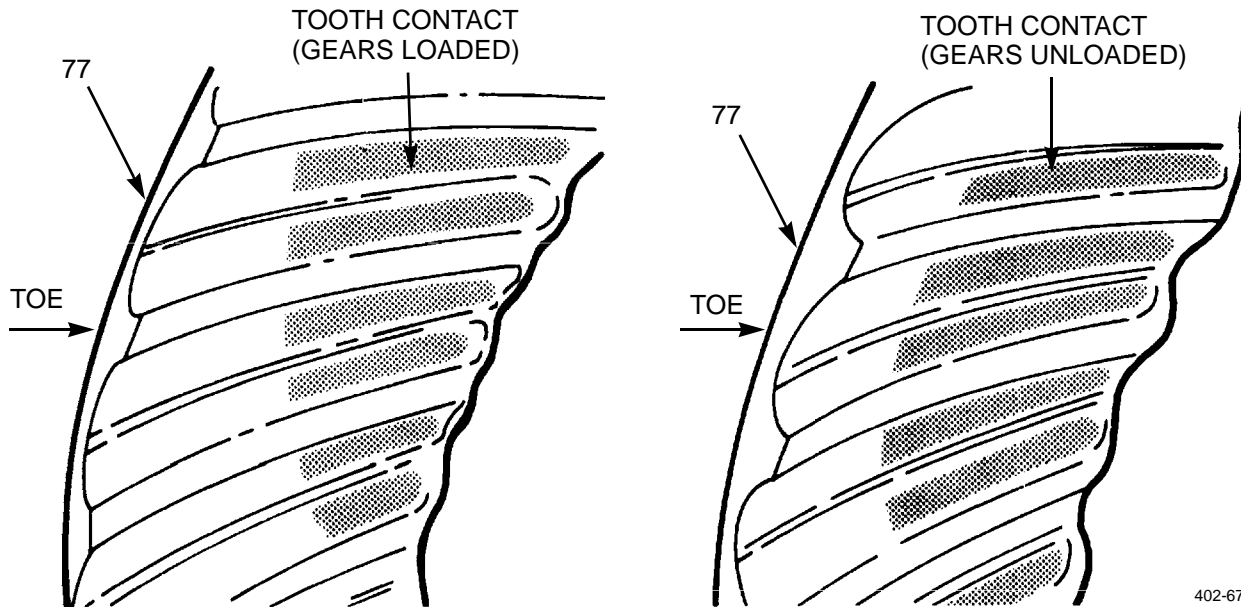

402-679

- (1) Apply a coat of Prussian blue paste lightly to the ring gear (77) teeth. When the pinion is rotated, the blue paste is squeezed away by the contact of the teeth, leaving bare areas the exact size, shape, and location of the contacts.
- (2) Sharper hand roll impressions may be obtained by applying a small amount of resistance to the gear with a flat steel bar and using a wrench to rotate the pinion. When making adjustments, check the drive side of the gear teeth. Coast side should be automatically correct when drive side is correct. As a rule, coating about twelve teeth is sufficient for checking purposes.
- (3) After obtaining a satisfactory tooth contact, the backlash can be altered within the limits of 0.005-0.015 in. (0.127-0.381 mm) for forward rear axle. Use 0.008-0.020 in. (0.203-0.508 mm) for rear-rear axle gears to obtain a better contact position relative to the length of the tooth.
- (4) A high backlash setting can be used to keep the contact from starting too close to the toe, and a low backlash setting can be used to keep the contact from starting too far away from the toe.
- (5) After correct tooth contact has been established, install thrust screw (78) and jam nut (79).

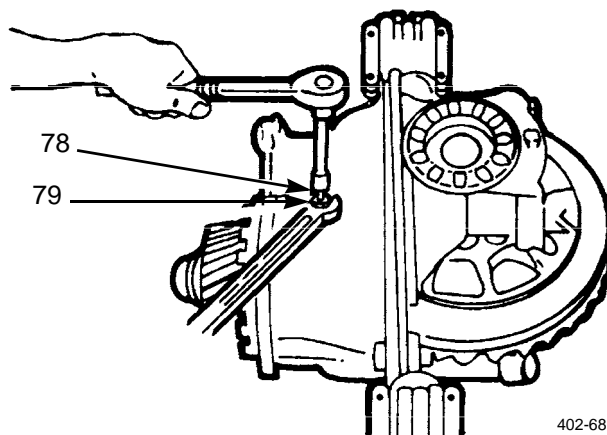

402-681



**DIFFERENTIAL CARRIER ASSEMBLY - CONTINUED**

- (6) With adjustments properly made (pinion at correct depth and backlash set at 0.010 in. (0.254 mm) the contacts will be procured. The area of contact favors the toe and is centered between the top and bottom of the tooth.
- (7) After final adjustments, install cotter pins in adjusting rings.
- (8) The hand-rolled pattern shown (gears unloaded), will result in a pattern centered in the length of the tooth when the gears are under load, as shown (gears loaded). The loaded pattern will be almost full length and the top of pattern will approach the top of the gear tooth.
- (9) The pattern on the coast side of teeth will appear the same width as the drive side shown above; however, the overall length will be centered between the toe and heel of gear tooth, After the correct contacts, as shown, have been established with a backlash of 0.010 in. (0.254 mm), open the backlash to measure between 0.005-0.015 in. (0.127-0.381 mm), if required.
- (10) Set used gear to have the tooth contacts to match wear patterns. Hand-rolled patterns of used gears will be smaller in area and should be at the toe end of wear patterns.
- (11) Incorrect patterns are shown. A low contact indicates pinion is too deep. Set the pinion to the correct depth by adding shims under the bearing cage. Slight inward movement of the gear may be necessary to maintain correct backlash.

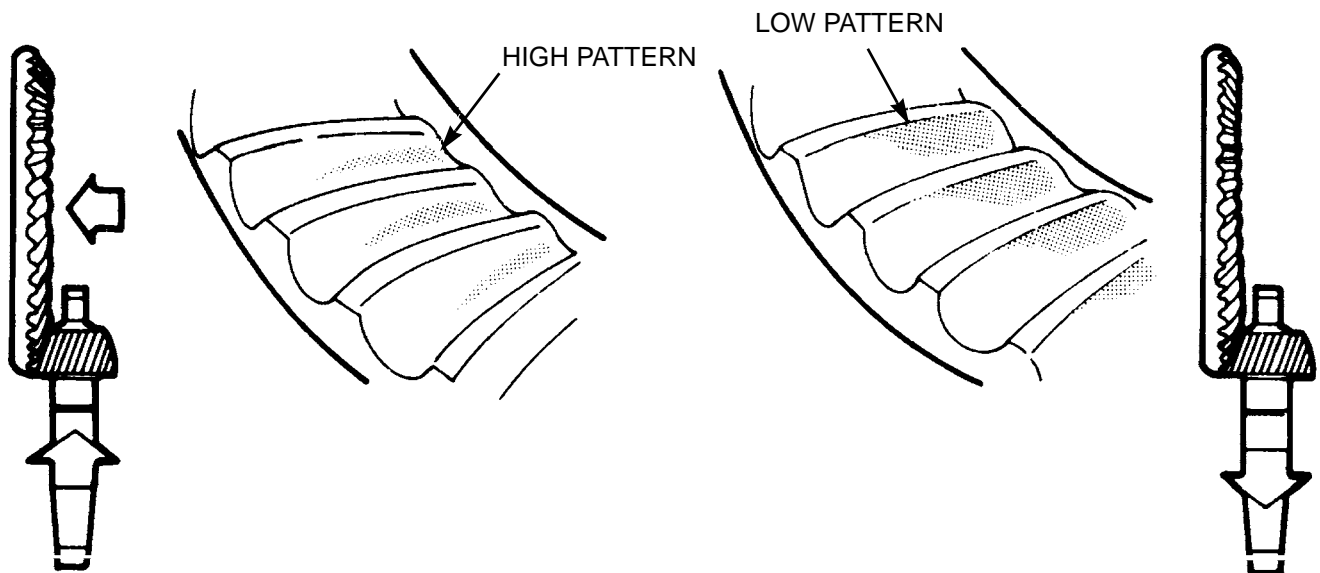

402-680

**DIFFERENTIAL CARRIER ASSEMBLY - CONTINUED**g. **Adjust Drive Gear Thrust Screw.**

- (1) Back out thrust screw (78) and jam nut (79).

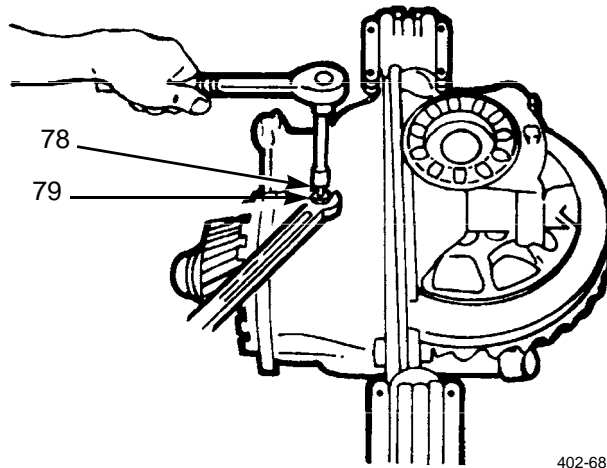

- (2) Coat thrust end of screw with grease and reinstall screw and jam nut into carrier.
- (3) Tighten screw until it is firm against back face of ring gear.
- (4) To secure the correct adjustment of 0.010-0.015 in. clearance, loosen thrust screw 1/4 turn and lock securely with nut. Torque nut 40-55 lb-ft (54-75 Nm).
- (5) Recheck clearance between end of thrust screw and back face of ring gear for 0.010-0.015 in. (0.254-0.381 mm) clearance.

**DIFFERENTIAL CARRIER ASSEMBLY - CONTINUED**h. **Assemble Interaxle Differential.**

- (1) Place the differential carrier (59) (attached to repair stand) in an upright position (pinion nut pointing upward).
- (2) Pre-lubricate all interaxle differential parts, such as inside walls of interaxle differential case halves (64 and 67), spider (68), pinions (66), thrust washers (65), and bearing (62), etc., with the recommended axle lubricant (Item 33, WP 0312 00).

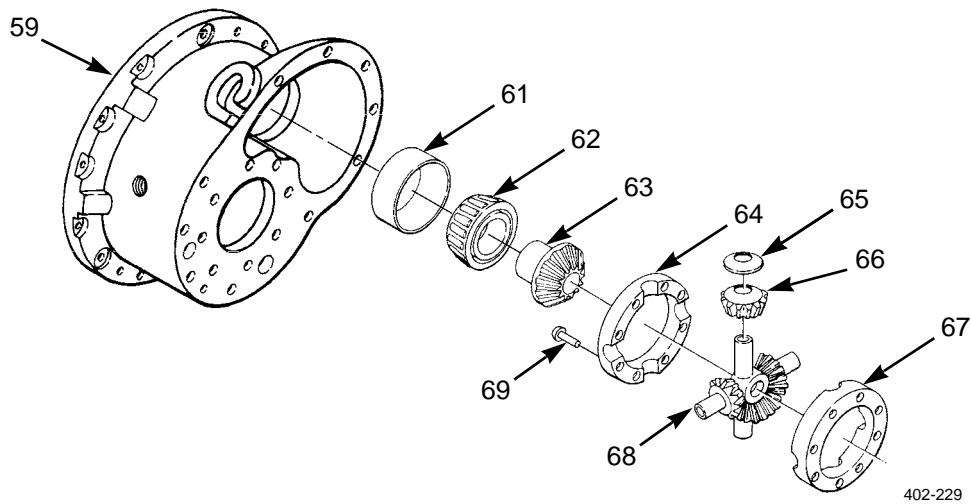

402-229

- (3) Press bearing cup (61) squarely into differential carrier (59) and bearing (62) squarely onto rear interaxle differential side gear (63) hub.

**DIFFERENTIAL CARRIER ASSEMBLY - CONTINUED**

- (4) Position the interaxle differential (57) (rivet or bolt heads up) into the carrier housing (59) and over the rear side gear (63).

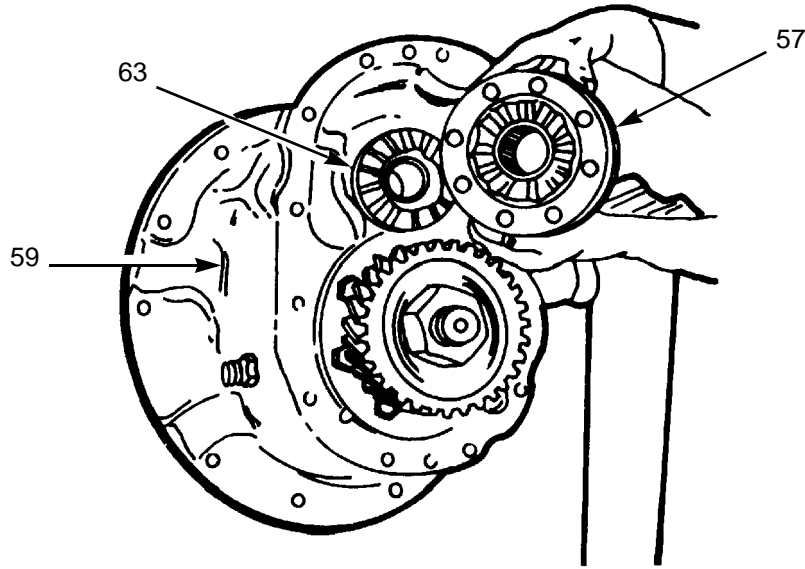

402-683

- (5) To assemble the forward side gear (55) and drive gear (54), first position the woodruff key (60) in place on the side gear hub.

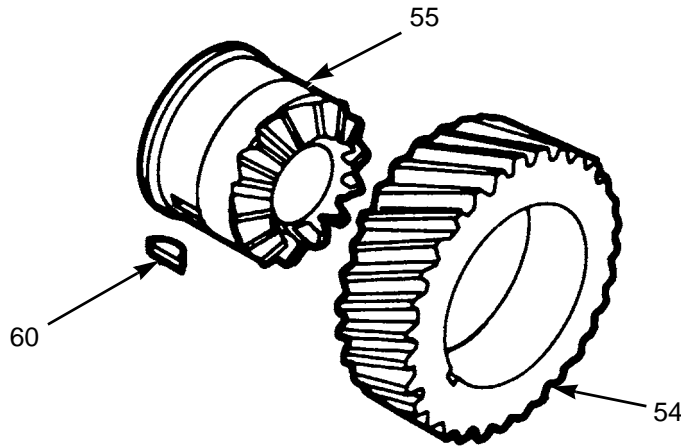

402-684

**DIFFERENTIAL CARRIER ASSEMBLY - CONTINUED****NOTE**

If the drive gear must be replaced with a new gear, replace both the drive and driven gears as a set.

- (6) Place drive gear (54) in a press with the flat side down and position the side gear (gear side down) with woodruff key (60) over the drive gear. Make sure the woodruff key aligns with the keyway in the I.D. of the drive gear.
- (7) Press the side gear (92) into the drive gear (54) until it bottoms.
- (8) Position the forward side gear and drive gear assembly over the interaxle differential case assembly (57) already in position. Ensure that alignment marks are in proper position as shown.

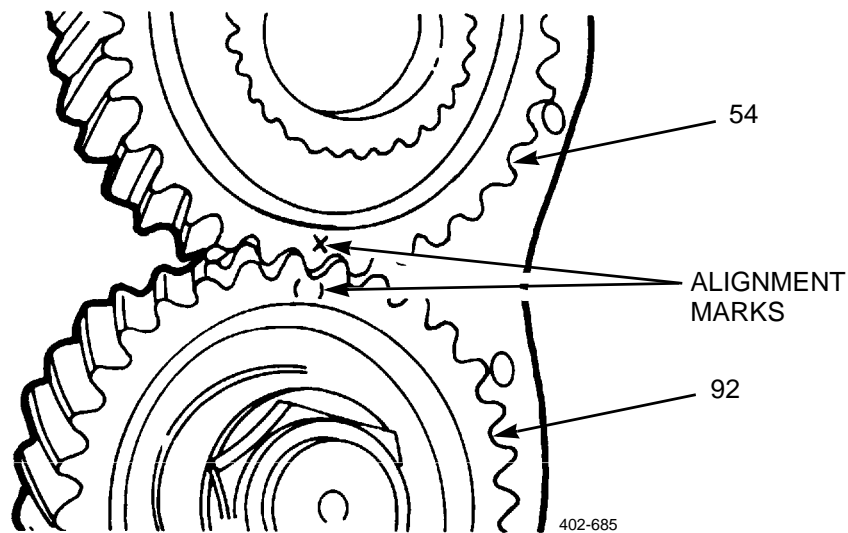

- (9) When placing the side gear and drive gear assembly in position on the carrier, be sure to align mating marks of both the drive and driven gears (92) as shown; if new gears are installed, mark one tooth of each gear, as shown.
- (10) Check for free rotation of the gears (54 and 92).

**DIFFERENTIAL CARRIER ASSEMBLY - CONTINUED**

- (11) Clean and install the internal oil filter screen (58) in its seat in the carrier (59).

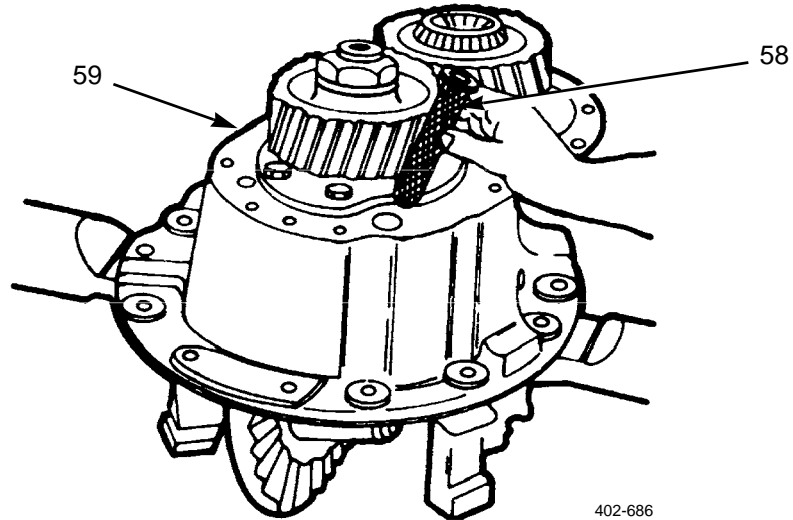

- (12) Set the differential carrier (59) assembly aside at this time and continue with assembling the gear cover (17).

i. **Install Oil Pump Drive.**

- (1) After dipping shaft in oil to assure lubrication before running, insert the shaft (40) of the oil pump drive gear through bore inside the gear cover (17).
- (2) Hold the gear in place from the inside of the gear cover (17) and install the washer (51) and lockring (52).

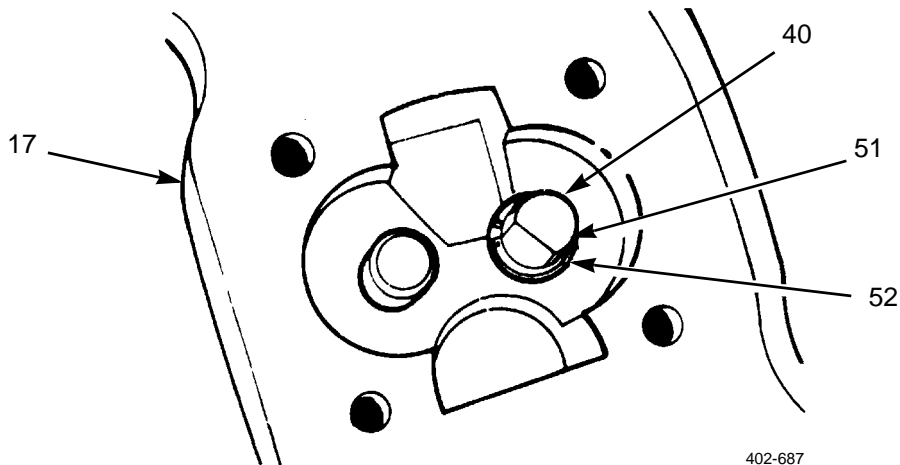

**DIFFERENTIAL CARRIER ASSEMBLY - CONTINUED**j. **Assemble the Shift Unit, Fork, and Shaft.****NOTE**

Before installing the shift shaft into the helical gear cover and shift fork, inspect and remove any rough spots or burrs by polishing the shaft with fine emery cloth.

- (1) Install the shift shaft (46) partially through its bore in the shift unit opening of the helical gear cover (17). Install the short end of shaft first (Measure from the roll pin hole to shaft ends to determine short end). Use a rawhide mallet to tap the shaft through.

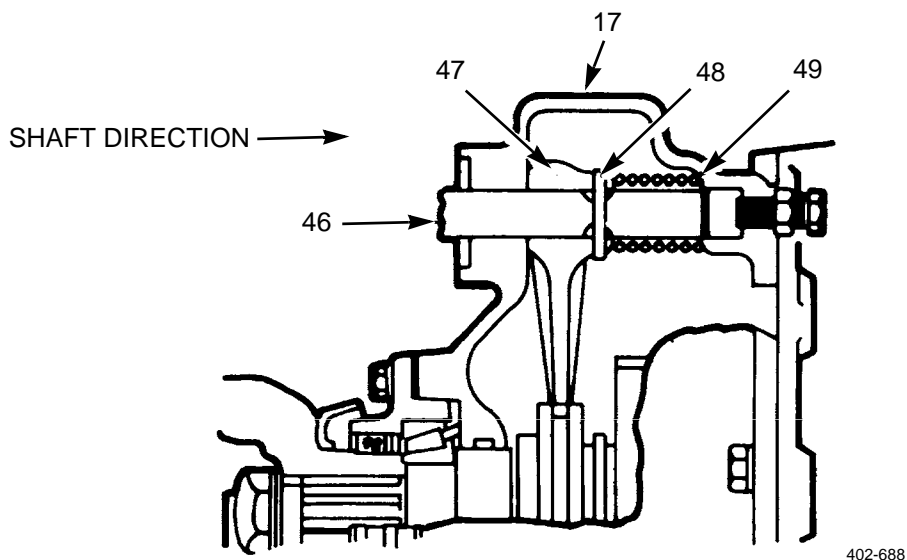

- (2) Position the shift fork (47) to the inside front of the helical gear cover (17), aligning its shaft bore with the bore in the cover. The long boss of the fork with the drilled roll pin hole must be facing toward the back.
- (3) Holding the shift fork (47) in position, continue to tap the shift shaft (46) through the gear cover (17) and fork. Tap shaft in enough to support the fork.
- (4) Install the shift fork return spring (49) between the fork (47) and rear shaft bore in the gear cover (17). Make sure inner diameter of spring coils are aligned with the shaft bores of the fork and gear cover.
- (5) Continue to tap the shift shaft (45) into position with the rawhide mallet.

**NOTE**

As the shaft is installed, make sure the roll pin holes of the fork and shaft are aligned. Rotate the shaft if necessary to align holes.

- (6) Assemble the roll pin (48) through the holes in the fork (47) boss and shaft (46). Use a small drift and hammer.

**DIFFERENTIAL CARRIER ASSEMBLY - CONTINUED**

- (7) Assemble the shift unit air chamber (44) over the shift shaft (43) and onto the helical gear cover (17). Install bolt retainers (45) and bolts (41). Torque to 75-100 lb-in. (8.5-11.3 Nm).

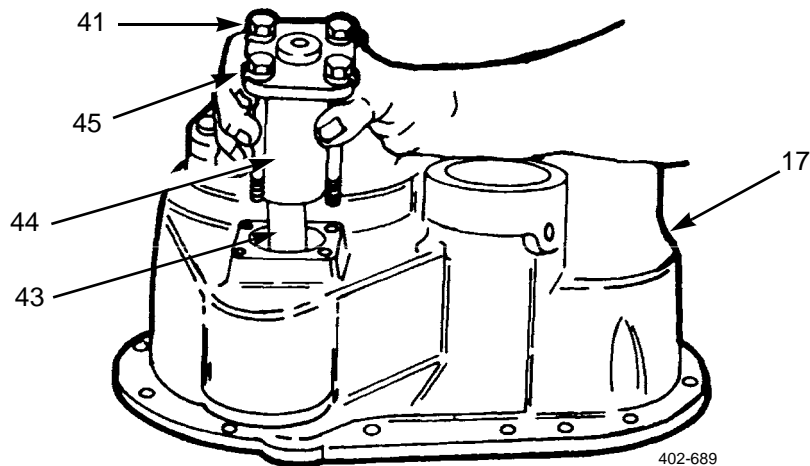

- (8) After tightening the bolts (41), bend one ear of each retainer (45) up against the bolt head. Bend the other two down against the top plate (42) of the chamber.

k. **Assemble Input Shaft and Bearings.**

- (1) Install the input shaft (53) and the interaxle differential shift collar into the gear cover (17). While holding the shift collar in position engaging it with the shift fork (47), insert the input shaft through the collar. Index the shaft and/or collar to engage splines. At the same time the shaft splines must engage the oil pump drive gear.

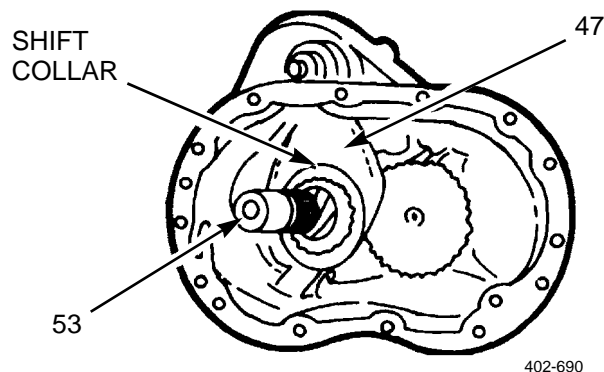

- (2) Press the forward bearing cone onto the input shaft while securing the shaft in position in the gear cover (17).
- (3) Press the forward input bearing cup squarely into the bearing cage.



**DIFFERENTIAL CARRIER ASSEMBLY - CONTINUED****CAUTION**

Do not exert pressure on the seal retainer after it bottoms. Damage to the seal will result.

- (4) If the front oil seal was removed, install a new seal into the front of the bearing cage. Coat the sealing lip with oil (Item 33, WP 0312 00) and outer diameter of retainer with a non-hardening sealing material, such as compound (Item 14, WP 0312 00). Use a press or arbor and suitable sleeve and press seal into position until it bottoms in the bearing cage.
  - (5) When the original input shaft forward bearing is reused, assemble the original shim pack and bearing cage with the bearing cup onto the gear cover. Secure the cage with capscrews and washers. Torque to 35-50 lb-ft (47-68 Nm).
  - (6) If a new bearing is used, assemble the bearing cage with a new cup over the helical gear cover. Do not install a shim pack. Assemble and tighten the capscrews and washers to finger-tight while rotating the shaft to seat bearings.
1. **Assemble the Oil Pump, Filter, and Cover.**
- (1) Assemble the oil pump relief valve cover (26) by inserting ball (30), spring (small diameter against ball) (31), and hollow capscrew (32). Torque capscrew to 40-55 lb-ft (54-75 Nm).

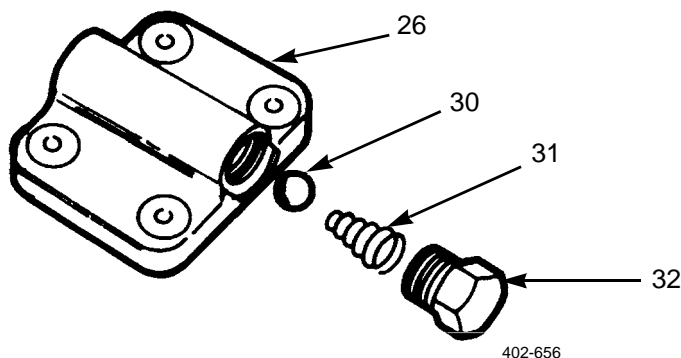

**DIFFERENTIAL CARRIER ASSEMBLY - CONTINUED**

- (2) Install oil pump gears (29) on their shafts in the cover (17).

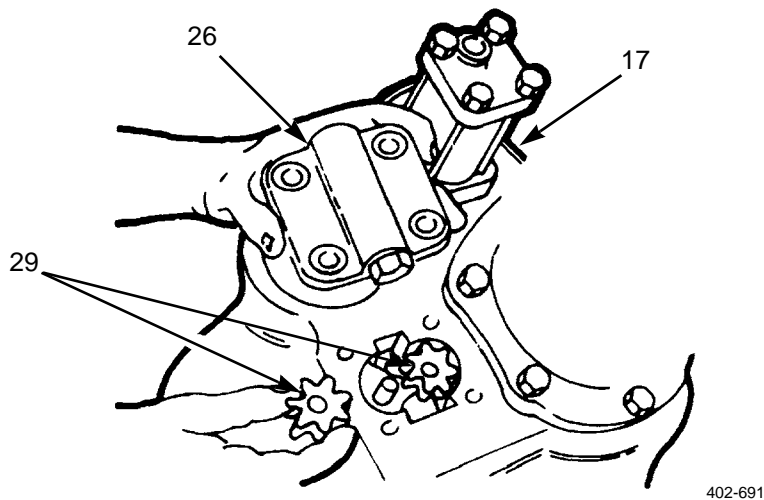

- (3) Pack the pump cavity completely with Lubriplate before installing the pump relief valve cover.
- (4) Assemble the oil pump relief valve cover (26) over gears (29) and secure to the gear cover (17) with two washers and short capscrews. (Install the two capscrews in the holes farthest from oil filter opening.) Torque to 20-30 lb-ft (27-41 Nm).
- (5) Position the oil filter adapter (25) in its bore in the gear cover (17). Install washers (28) and capscrews (27), and torque to 20-30 lb-ft (27-41 Nm).

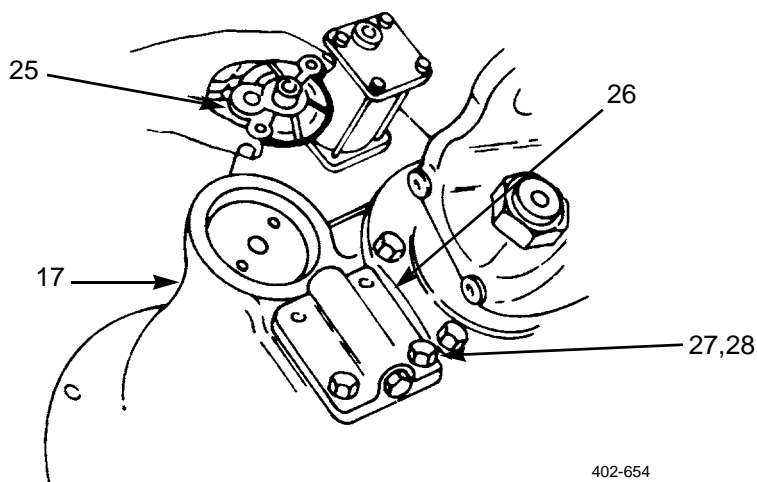

**DIFFERENTIAL CARRIER ASSEMBLY - CONTINUED**

- (6) Pour or squirt two ounces of specified drive unit lubricant (Item 33, WP 0312 00) into the oil pump to filter passage.

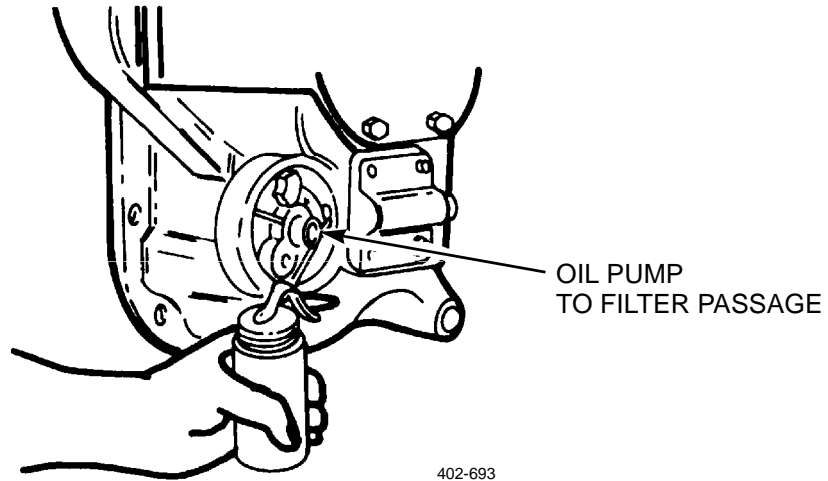
**CAUTION**

If the filter is tightened more than one turn after contacting gasket, damage to the filter may result.

- (7) Coat the face of the gasket on the new oil filter (24) with the gear lube (Item 33, WP 0312 00). Install the oil filter on gear cover (17) and tighten one full turn after the gasket contacts the base, using a filter strap wrench. Do not overtighten.

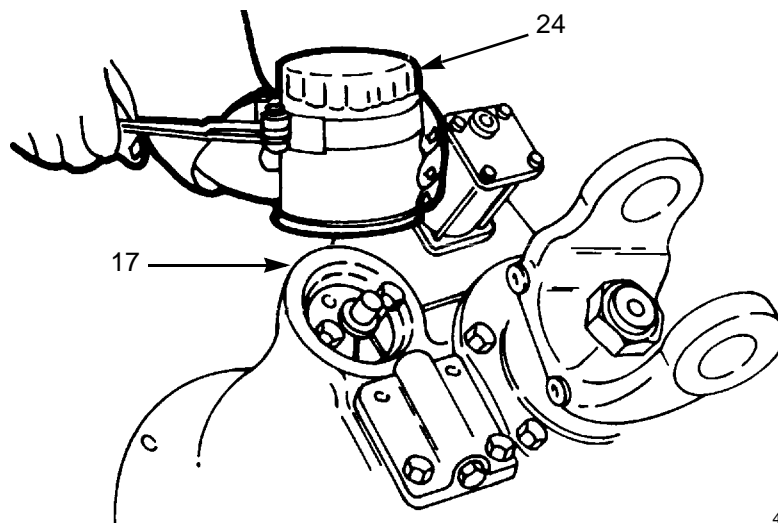

**DIFFERENTIAL CARRIER ASSEMBLY - CONTINUED**

- (8) Install filter cover (23) over filter (24) and secure with two nuts (22). Torque to 20-30 lb-ft (27-41 Nm).

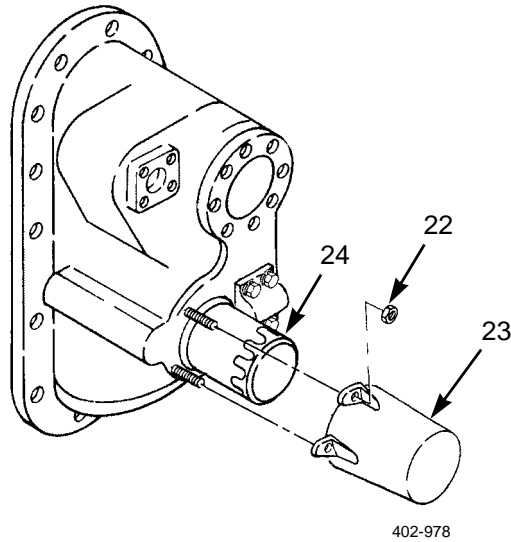

m. **Assemble and Install Input Shaft Yoke.**

**CAUTION**

Do not drive yoke onto shaft by pounding or tapping.

- (1) Coat yoke (15) seal elements with gear lube. Also ensure that there are no burrs or nicks on the yoke wiper surface or on any surfaces that will pass through the seal during installation.
- (2) Install slinger on input shaft (33).
- (3) Thread the yoke installation shaft into pinion input, output or through-shaft until installation shaft bottoms.

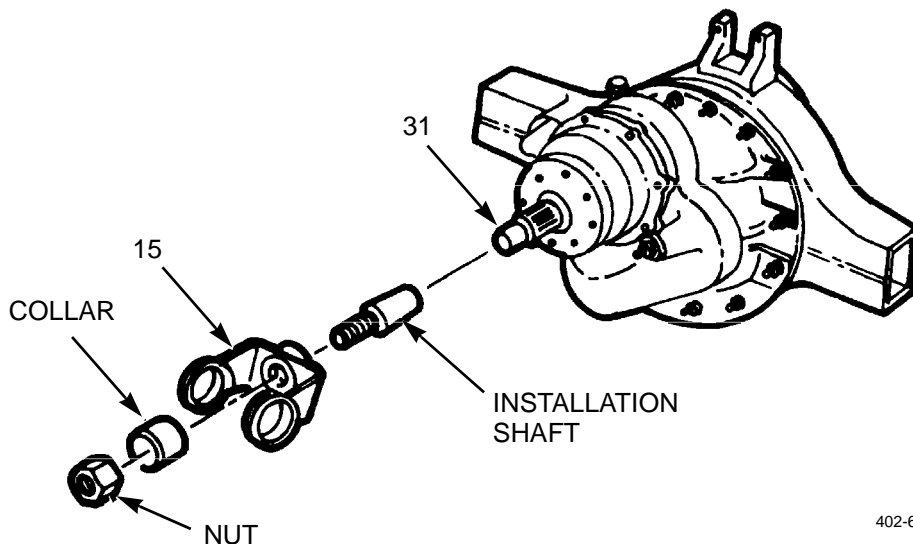

**DIFFERENTIAL CARRIER ASSEMBLY - CONTINUED**

- (4) Slide the yoke (15) over the installation shaft, aligning yoke and shaft splines of drive unit.
- (5) Place installation collar over the installation shaft, against yoke (15).
- (6) Thread nut onto installation shaft, against the collar. Continue threading the nut against collar until yoke (15) seats against bearing. A torque value of 200 lb-ft (270 Nm) on nut may be required to properly install and seat yoke.

**CAUTION**

Do not use a prevailing torque nut to install the yoke, as damage to the threads will result. Use only the nut furnished with tool.

- (7) Remove all parts of the installation tool from the drive unit.
- (8) Install washer and nut (16). Tighten nut to 450-600 lb-ft (610-813 Nm).

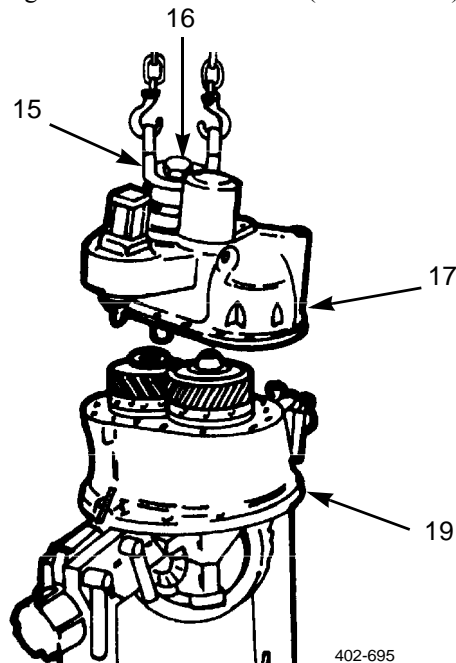
n. **Assemble the Gear Cover onto Carrier.**

- (1) Before assembling the cover (17) to differential carrier (19), coat the forward interaxle differential side gear thrust washer (57) and back face of integral shift collar gear (on input shaft) (33) with grease (Item 23, WP 0312 00).
- (2) Place the thrust washer (57) onto the back face of shift collar gear (33). The grease will allow the washer to stick to the gear.

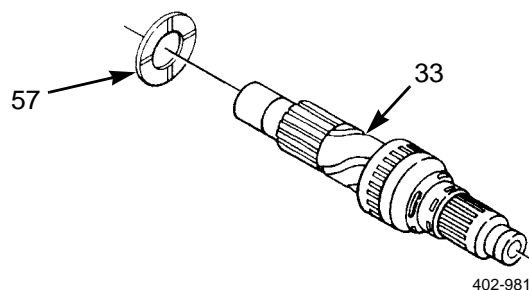

**DIFFERENTIAL CARRIER ASSEMBLY - CONTINUED****CAUTION**

Do not assemble the thrust washer onto the forward side gear in carrier. Damage to the washer will occur if the slightest misalignment is present.

- (3) Apply silicone gasket material to the mating surfaces of the two cases (17 and 19) and position gasket (18) to case (19).
- (4) Using a hoist attached to the input yoke (15), position the gear cover (17) above the differential carrier (19).

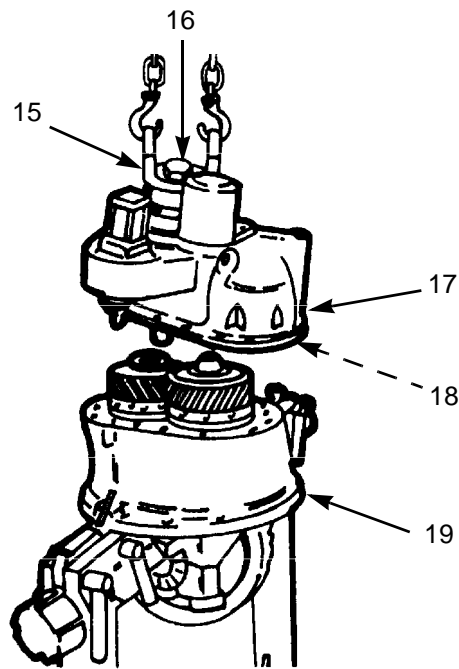

402-695



**DIFFERENTIAL CARRIER ASSEMBLY - CONTINUED**o. **Adjust Input Bearing End Play.****NOTE**

If original input shaft forward bearing was installed with original shim pack (*Assemble Input Shaft and Bearings*, k, (5), tighten yoke nut enough to eliminate any play between the yoke and bearings; then proceed to step (5).

- (1) With the forward input bearing in place and the bearing cover (34) assembled finger-tight on the helical gear cover (17) with no shim pack, measure the gap between the bearing cover and helical gear cover using a feeler gage.
- (2) Add approximately 0.005 inch (0.127 mm) to measurement figure of gap. Add this amount of shims under the bearing cover (34).

**NOTE**

Use a minimum of three shims under bearing cover with the thinnest shims on outer sides.

- (3) Remove the input yoke (15) if assembled and bearing cover (34) and install the initial amount of shims. Reassemble the cover, washers (36) and capscrews (32). Torque capscrews to 35-50 lb-ft (47-68 Nm).
- (4) Assemble the input yoke (15) and nut (16) over the input shaft (33). Tighten the yoke nut enough to eliminate any play between the yoke and the bearing.
- (5) Check the bearing end play using a dial indicator mounted against the nose of the input shaft (33). Use a dial indicator with a magnetic base or c clamp arrangement mounted on the helical gear cover (17).

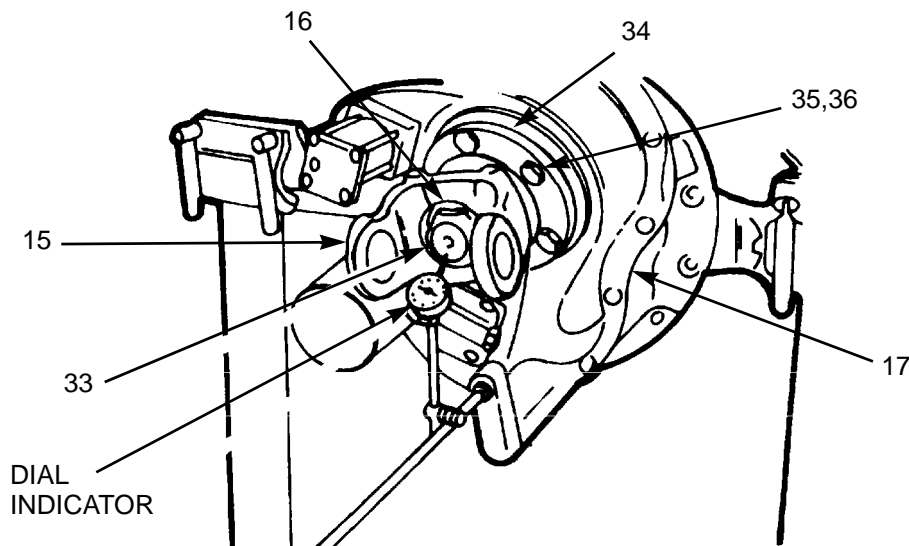

402-696

- (6) Holding the input yoke (15), push in the input bearing while turning the yoke side to side to seat the bearing. Set the indicator to zero.
- (7) Next, pull the yoke (15) outward, again turning it side to side and take note of reading on the dial indicator.
- (8) Final end play must be between 0.003-0.007 inch (0.076-0.178 mm). If not, adjust by either adding or removing shims from under the bearing cover (28) and repeat above procedures.



**DIFFERENTIAL CARRIER ASSEMBLY - CONTINUED****NOTE**

Add shims to increase end play; remove shims to decrease end play.

- (9) After correct end play has been established, torque the input yoke nut (16) to 450-600 lb-ft (610-813 Nm).
- p. **Adjust Shift Shaft.**
- (1) If the shift shaft adjusting screw (78) and jam nut (79) have not been assembled, install both parts into the gear cover (17) in back of the shift shaft (91). Turn in the adjusting screw approximately two turns at this time.
  - (2) Using a shop air supply, apply air pressure to the air chamber. This will move the shift shaft (46), fork (47) and collar (48) back, locking the interaxle differential.
  - (3) Make sure the collar (48) travels over the splines (49) and engages with the rear side gear (55). If necessary, index the shift collar by turning the input shaft.
  - (4) With the shift shaft (46) moved back its full travel, turn in the adjusting screw (78) until it just touches the end of the shift shaft.
  - (5) From this point continue turning in screw (78) 1-1 1/4 turns more and lock adjusting screw with jam nut (79); torque jam nut to 40-55 lb-ft (54-75 Nm). This will allow correct clearance between the fork (47) and groove of the collar, thus eliminating wear.
  - (6) After shift shaft (46) adjustment has been made, remove the air line from the air chamber.

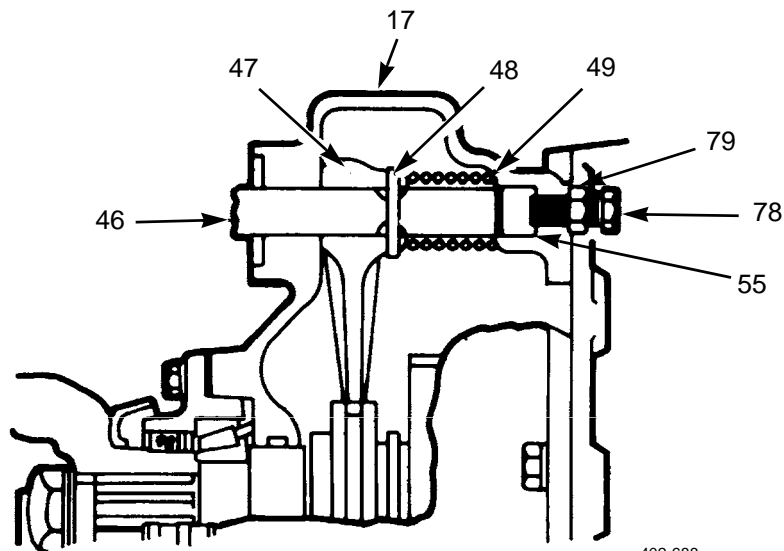

402-688

**OUTPUT SHAFT ASSEMBLY**

- a. Coat bearings (11) with recommended axle lubricant (Item 33, WP 0312 00) and press both inner and outer bearing cones (back-to-back) onto end of output shaft (14) until inner bearing cone bottoms on the shaft shoulder. Use a press and suitable sleeve.

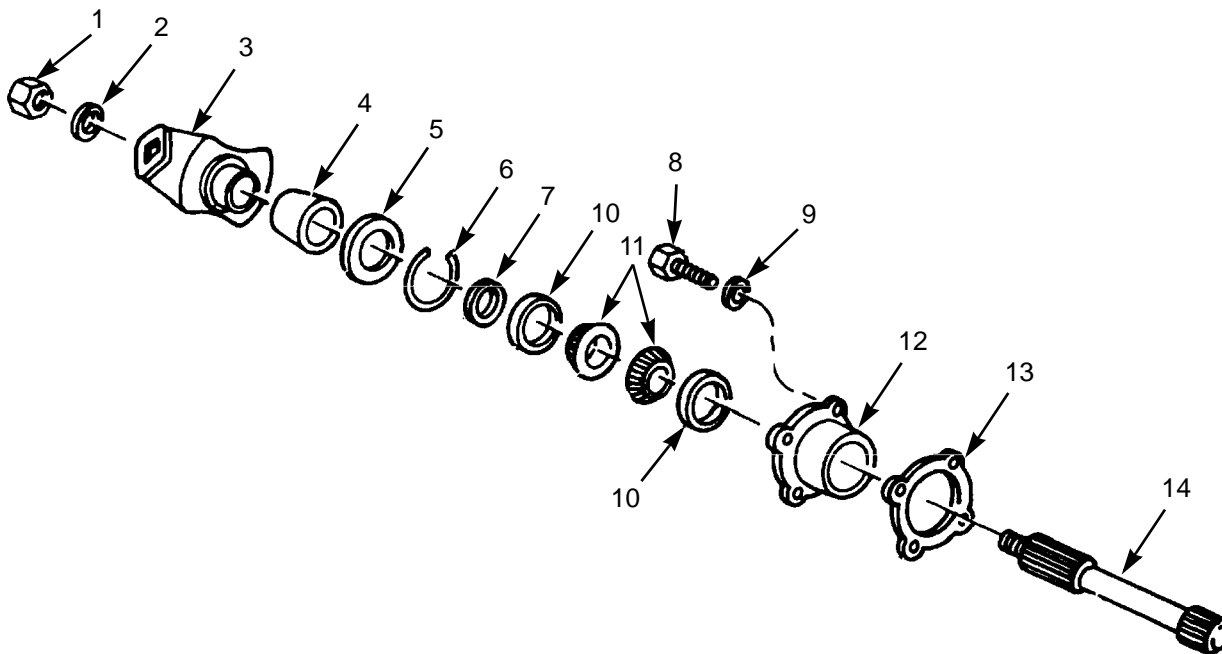

402-697

**CAUTION**

Use soft metal shields over vise jaws to avoid damaging the cage.

- b. Secure the output shaft cage (12) in a vise and place the inner bearing cup (10) in position in the cage and insert the output shaft with bearing cones (11) through the cage.
- c. Position the outer bearing cup (10) into the cage (12) and over the bearing cone (11) on the output shaft (14). Secure bearings and shaft in the cage with a washer (7) and retaining ring (6), snap ring bearing spacer (5). This retaining ring also controls the bearing end play.

**NOTE**

Do not assemble the oil seal or yoke at this time.

**OUTPUT SHAFT INSTALLATION**

- a. **Adjust Bearing End Play.**

**NOTE**

The output bearing end play is controlled by the thickness of the retaining ring (6). The retaining ring is available in thicknesses ranging from 0.155-0.182 inch in increments of 0.003 inch. Select and install one retaining ring to obtain a 0.0001-0.0030 inch (0.0025-0.0762 mm) bearing end play. Use the following procedures.

**OUTPUT SHAFT INSTALLATION - CONTINUED**

- (1) With the bearing cage (12) output and shaft (14) assembly secured in a vise, attach a dial indicator to the cage flange. Adjust the indicator so its pointer contacts the end of the output shaft and set the dial to zero.
- (2) While observing the dial, pull the output shaft to rack in the output bearings (11) while turning the shaft side-to-side to seat the bearings.
- (3) Next, push the output shaft (14) while turning it side-to-side and take note of the dial indicator reading.
- (4) Final end play should be between 0.0001-0.0030 inch. If the bearing end play does not fall within this range, replace the retaining ring (6).

**NOTE**

A thinner retaining ring (6) will increase end play, and a thicker retaining ring (6) will decrease end play.

- (5) After establishing correct bearing end play, assemble the yoke (3) and bushing (4) onto the output shaft against the outer bearing (11). Secure the yoke with washer (2) and nut and torque to 450-600 lb-ft (610-813 Nm).

**NOTE**

Use a yoke holder while tightening the yoke nut.

- (6) Using the dial indicator, make a second check of the bearing end play with the yoke (3) installed. Use the same procedures as with the first check, steps (1) thru (3).
- (7) Remove the yoke (3) from the output shaft using a yoke holder while loosening the nut (1).
- (8) Coat the output seal (5) lips with oil (Item 33, WP 0319 00) and outer diameter of output shaft cage (12) with a non-hardening sealing material, such as compound (Item 14, WP 0319 00).

**CAUTION**

Do not exert pressure on the seal retainer after it bottoms. Damage to seal will result.

- (9) Assemble the oil seal (5) into the cage (12) by placing the output shaft and cage assembly in a press. Use a suitable sleeve having a diameter that will fit inside the cage inner diameter and press in the seal until it bottoms in cage. If a press is not available, use the sleeve and a mallet to seat the seal in the cage.
- b. **Install Output Shaft and Yoke.**
- (1) Install the output shaft and cage assembly into the axle housing. It may be necessary to rotate the shaft to index splines of shaft and side gear. Secure the cage (12) to housing with washer (9) and capscrews (8). Torque capscrews to 35-50 lb-ft (47-68 Nm).
  - (2) Install the output yoke (3) as described in *Assemble and Install Input Shaft Yoke* (m).

**END OF WORK PACKAGE**



---

**REAR-REAR AXLE DIFFERENTIAL CARRIER REPLACEMENT**

---

**0258 00****THIS WORK PACKAGE COVERS**

Removal, Installation

---

**INITIAL SETUP****Maintenance Level**

Direct Support

**Tools and Special Tools**

Tool kit, general mechanic's (Item 102, WP 0313 00)

Jack, hydraulic (Item 52, WP 0313 00)

Wrench, torque, 50-250 lb-ft (Item 111, WP 0313 00)

**Materials/Parts**

Compound, sealing (Item 15, WP 0312 00)

Rags, wiping (Item 42, WP 0312 00)

**Personnel Required**

Two

**Equipment Condition**

Axle shafts removed (WP 0116 00)

Intermediate driveline disconnected (WP 0116 00)

Axle oil drained (WP 0120 00)

**WARNING**

Use extreme caution when handling heavy parts. Provide adequate support and use assistance during procedure. Ensure that any lifting device used is in good condition and of suitable load capacity. Keep clear of heavy parts supported only by lifting device. Failure to follow this warning may result in death or injury to personnel.

**REMOVAL****WARNING**

Rear-rear differential carrier weighs 860 lb (390 kg). Support with suitable floor jack prior to removal to prevent injury to personnel.

**NOTE**

If axle assembly has been removed from vehicle, perform steps 1 through 3 only.

1. Remove 12 screws (1 and 4) and flat washers (2 and 5).
2. Loosen differential carrier (3) by tapping around flange.
3. Remove differential carrier (3) from axle (6).
4. Lower differential carrier (3) onto floor jack and roll differential carrier from under vehicle.

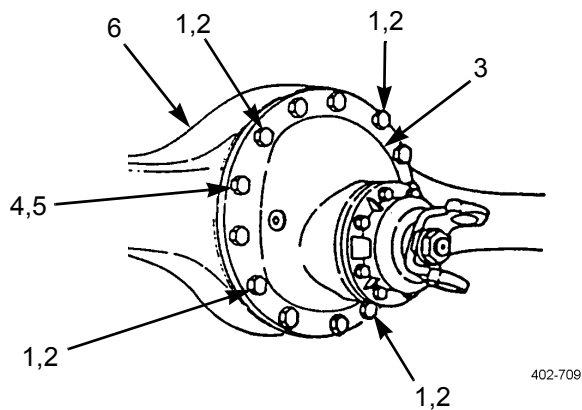
**INSTALLATION****WARNING**

Rear-rear differential carrier weighs 860 lb (390 kg). Support with suitable floor jack prior to installation to prevent injury to personnel.

**NOTE**

If axle assembly has been removed from vehicle, perform steps 3 through 5 only.

1. Position differential carrier (3) on floor jack and roll differential carrier into position under vehicle.

**CAUTION**

Ensure both mating surfaces have been completely cleaned to prevent damage to equipment.

***INSTALLATION - CONTINUED***

2. Apply sealing compound around mating surface of axle (6).
3. Attach suitable hoist and install differential carrier (3) to axle (6) with four flat washers (2) and screws (1) in four corner locations around differential carrier. Hand tighten screws.
4. Seat differential carrier (3) and tighten four screws (1) in crisscross pattern.
5. Repeat step 4 until differential carrier (3) is completely seated. Tighten four screws (1) to 150-230 lb-ft (203-312 Nm).
6. Install eight flat washers (5) and screws (4). Tighten screws in crisscross pattern to 150-230 lb-ft (203-312 Nm).
7. Connect intermediate driveline (WP 0116 00).
8. Install axle shafts (WP 0116 00).
9. Fill axle with oil (WP 0120 00).

**END OF WORK PACKAGE**





**REAR-REAR AXLE DIFFERENTIAL CARRIER REPAIR**

**0259 00**

**THIS WORK PACKAGE COVERS**

Disassembly, Assembly

**INITIAL SETUP**

**Maintenance Level**

General Support

**Tools and Special Tools**

- Tool kit, general mechanic's (Item 102, WP 0313 00)
- Dial indicator set (Item 18, WP 0313 00)
- Holding bar, pinion (Item 35, WP 0313 00)
- Multiplier, torque wrench (Item 61, WP 0313 00)
- Press, arbor (Item 71, WP 0313 00)
- Scale (Item 80, WP 0313 00)
- Wrench, torque, 15-75 lb-ft (Item 110, WP 0313 00)
- Wrench, torque, 100-600 lb-ft (Item 112, WP 0313 00)

**Materials/Parts**

- Grease, GAA (Item 23, WP 0312 00)
- Oil, lubricating (Item 33, WP 0312 00)
- Paste, Prussian blue (Item 36, WP 0312 00)
- Rags, wiping (Item 39, WP 0312 00)
- Wire, non-electrical (Item 50, WP 0312 00)
- Nut, lock (P/N 40X-1026)
- Seal, oil (P/N A-1205-H-2426)

**Personnel Required**

Two

**References**

TM 9-214

**Equipment Condition**

Rear-rear axle differential carrier removed (WP 0258 00)

**DISASSEMBLY**



**WARNING**

Rear-rear axle differential carrier weighs 860 lbs (390 kg). Attach suitable floor jack prior to disassembly to prevent possible injury to personnel.

DISASSEMBLY - CONTINUED

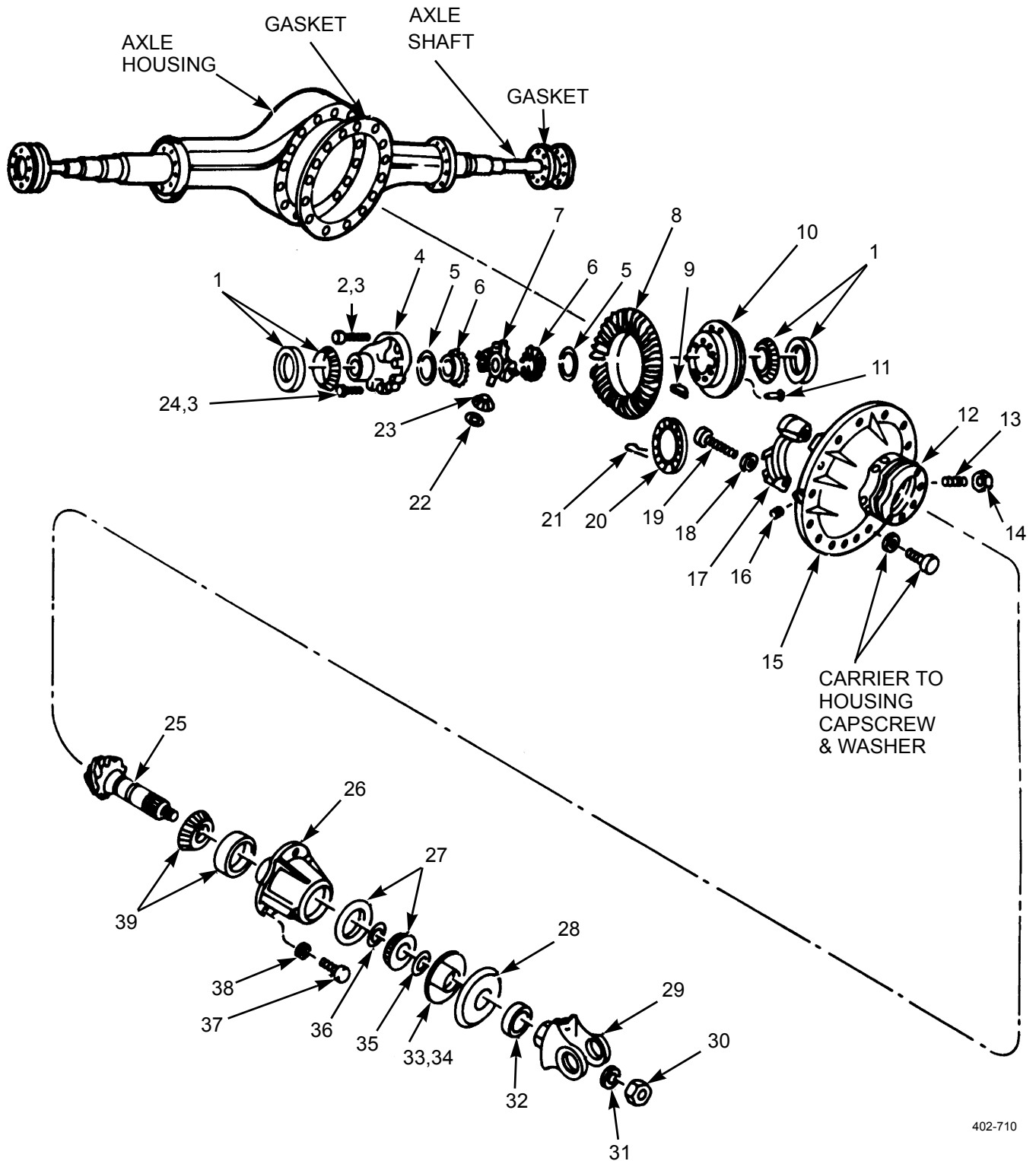

402-710

Figure 1. Rear-Rear Axle - Exploded View

**DIFFERENTIAL CARRIER DISASSEMBLY (FIG. 1)****a. Remove Differential and Gear Assembly.**

- (1) With the carrier (15) still in an upright position, loosen jam nut (14) and back off the drive gear thrust screw (13).
- (2) Rotate the carrier (15) 180° and bring the ring gear (8) to an upright position.
- (3) Check and record the backlash. This information will be needed in reassembly unless a new gear set is used.
- (4) Center-punch one differential carrier (15) leg and bearing cap (17) to identify at reassembly.
- (5) Remove the capscrews (19), washers (18), and cotter keys from both sides of the carrier (15).
- (6) Remove the bearing adjusting rings (20) and the bearing caps (17).
- (7) Remove the thrust block (9) from the inside of the carrier (15) housing. Remove oil fill plug (16).

**b. Disassemble Differential Case and Gear Assembly.**

- (1) If original identification (matching) marks are not clear, mark the differential case halves (4 and 10) with a punch for correct alignment at reassembly.
- (2) Remove the capscrews (2 and 24) and washers (3) and separate the case halves (4 and 10).
- (3) Remove the spider (7), pinions (23), side gears (6), and thrust washers (5 and 22).
- (4) If the ring gear (8) is to be replaced for any reason, remove the rivets (11) and separate ring gear from the case (10).
  - (a) Carefully center-punch rivets (11) in the center of the head on the gear side of the assembly.
  - (b) Use a drill 1/32-inch smaller than the body of the rivet (11) to drill through the head.
  - (c) Press out the rivets (11).
- (5) If necessary to replace the differential bearings (1), remove with a suitable puller.

**c. Remove Pinion and Cage Assembly.**

- (1) Hold the yoke (29) with a suitable tool and remove the pinion shaft nut (30) and washer (31).

**CAUTION**

Driving the yoke will cause run-out.

- (2) Remove the yoke (29) with a suitable puller. Remove wiper (32) and slinger (28).

**CAUTION**

The use of a pinch bar will damage the shims.

- (3) Remove the pinion cage capscrews (37) and washers (38), then remove the pinion cage (26) from the carrier (15).
- (4) Wire the shim pack (12) together to facilitate adjustment at reassembly.

**d. Disassemble Pinion and Cage Assembly.**

- (1) Tap the pinion shaft (25) out of the cage (26) with a soft mallet or press the shaft from the cage.
- (2) Remove the oil seal (33) and retainer (34) from the cage (26).
- (3) Remove the washers (35) and outer bearing (27) from the cage (26).
- (4) Remove the spacer (36) or spacer combination from the pinion shaft (25).
- (5) If necessary to replace the rear (inner) bearing (39), remove (with suitable puller) from the pinion shaft (25).

**DIFFERENTIAL CARRIER ASSEMBLY**

a. Assemble Pinion and Cage.

**CAUTION**

Take care not to damage the bearing rib in the cage.

- (1) Coat the bearings (27 and 39) with gear lube (Item 33, WP 0312 00) and if new cups are to be installed, press firmly against the pinion cage (26) shoulders.
- (2) Press the rear (inner) bearing (39) firmly against the pinion shaft (25) shoulder with a suitable sleeve that will bear only on the bearing inner race.
- (3) Insert the pinion shaft (25) and bearing (39) assembly in the pinion cage (26) and position the spacer (36) or spacer combination over the pinion shaft.
- (4) Press the front (outer) bearing (27) and washer (35) firmly against the spacer (36).
- (5) Rotate the cage (26) several revolutions to assure normal bearing contact.
- (6) While in the press, under pressure, check the bearing preload torque. Wrap a soft wire around the cage (26) and pull on a horizontal line with a pound scale.
- (7) If a press is not available, the pinion nut (30) may be tightened to the correct torque and the preload checked. The correct pressures and torque for checking the pinion bearing preload are as follows:

PINION SHAFT THREAD SIZE	REQUIRED NUT TORQUE TO OBTAIN CORRECT PRELOAD	REQUIRED PRESSURE TO OBTAIN CORRECT PRELOAD
1 1/4 inch x 12	700-900 lb-ft (949-1220 Nm)	11 tons (10 metric tons)

**NOTE**

Use rotating torque, not starting torque.

- (8) If rotating torque is not within 20-45 lb-in (2.3-5.1 Nm) for new bearings, or 10-22 lb-in (1.1-3.4 Nm) for reused bearings, use a thinner spacer (36) to increase or a thicker spacer to decrease the preload.
- (9) Press the yoke (29) against the forward bearing (27) and install the pinion shaft washer (31) and nut (30).
- (10) Place the pinion and cage assembly in the carrier (15) and secure with capscrews (37) and washers (38). Hold the flange and torque the pinion shaft nut (30) to 700-900 lb-ft (949-1220 Nm). The yoke (29) must be held with a suitable tool or fixture to tighten the nut.
- (11) Recheck the pinion bearing preload torque. If rotating torque is not within 15-25 lb-in (1.7-3.8 Nm), repeat the foregoing procedure.
- (12) Hold the yoke (29) and remove the pinion shaft nut (30) and washer (31). Remove the yoke.
- (13) Lubricate the oil seal (33) and coat the outer edge of the seal retainer (34) with a non-hardening sealing compound (Item 14, WP 0312 00). Press the seal and retainer against the shoulder of the pinion cage (26) with a seal driver.
- (14) Install slinger (28) and wiper (32).
- (15) Press the yoke (29) and washer (35) against the forward bearing (27) and install the washer (31) and pinion shaft nut (30). Torque to 700-900 lb-ft (949-1220 Nm).

**DIFFERENTIAL CARRIER ASSEMBLY - CONTINUED**b. **Install the Pinion and Cage Assembly.**(1) **Original Gear Set.**

- (a) If the original pinion shaft (25) and ring gear (8) are to be reassembled into the carrier (15), use the same shim pack (12), if reusable, between the pinion bearing cage (26) and the carrier. Otherwise, use a new shim pack of the same thickness.

**NOTE**

Use a minimum of three shims per pack.

- (b) Install the correct shim pack (12). Locate thin shims on both sides for maximum sealing ability.
- (c) Place the pinion and cage assembly (with shims) into the carrier (15) and tap into position with a soft mallet.
- (d) Install washers (18) and capscrews (19). Torque to 85-115 lb-ft (1 15-156 Nm).

**NOTE**

After the differential and gear assembly is installed into the carrier, make a gear tooth contact check.

(2) **New Gear Set.****NOTE**

If the pinion or drive gear require replacement, both must be replaced in matched sets.

- (a) Before installing a new pinion and gear set, check and compare the matching number of both the pinion and drive gear; they must be the same. An example of this number would be M29 or any combination of a letter and number marked on the nose of the pinion and on the front face of the drive gears.

**NOTE**

All amboid pinions have a nominal mounting distance and a plus or minus variation indicated as PC (pinion cone) marked in the same area. An example of these numbers would be 7.875 PC + 5. The PC number indicates the variation in thousandths from the nominal mounting distance for that specific gear set.

- (b) To determine the proper shim pack (12) thickness to be used with a new pinion and gear set, use one of the following procedures (c or d) as applicable.

c. **Adjust the Pinion Cage Shim Pack Thickness without Pinion Setting Gage.**

- (1) Measure the thickness of the original shim pack used with the gear set being replaced; use a micrometer or vernier gage. Make a note of this measurement.
- (2) Note the PC or variation number on the original pinion being replaced. If this number is a plus (+) value, subtract it from the original shim pack measurement taken in step (1). If the variation number is a minus (-) value, add it to the measurement from step (1). Make a note of this value.

**DIFFERENTIAL CARRIER ASSEMBLY - CONTINUED****NOTE**

The value calculated in step (2) will establish a "standard shim pack thickness" without a variation. This value will be used in calculating the shim pack thickness used with a new pinion and gear set.

- (3) Note the PC or variation number on the new pinion. Add or subtract this number as indicated by the variation sign (+ add or -subtract) from the calculated standard shim pack thickness determined in step (2).
- (4) The resulting answer indicates the thickness (in thousandths) of the new shim pack to be used. Use a minimum of three shims per pack.
- (5) Assemble the new pinion and cage assembly with the correct shim pack into the carrier.

**NOTE**

After assembling the pinion and cage assembly with new shim pack and differential and gear assembly into carrier, make a gear tooth contact check.

d. **Adjust the Pinion Cage Shim Pack Thickness with Pinion Setting Gage.**

- (1) Because the pinion setting gage measures the distance or depth of the pinion in the carrier from the center line of the main differential bearing bores to the nose of the pinion, it is necessary to calculate and establish the correct nominal or gage dimensions to work with.

**CAUTION**

Do not directly use the dimension (i.e., 7.875) stamped on the nose of the pinion for calculations when using the pinion setting gage.

- (2) The dimension (i.e., 7.875) stamped on the pinion indicates the distance from the center of the differential bearing bores to the pinion bearing shoulder. This dimension must be modified to a workable value as follows.

**DIFFERENTIAL CARRIER ASSEMBLY - CONTINUED**

- (3) Make a note of the nominal pinion mounting distance dimension stamped on the pinion nose (fig. 2).

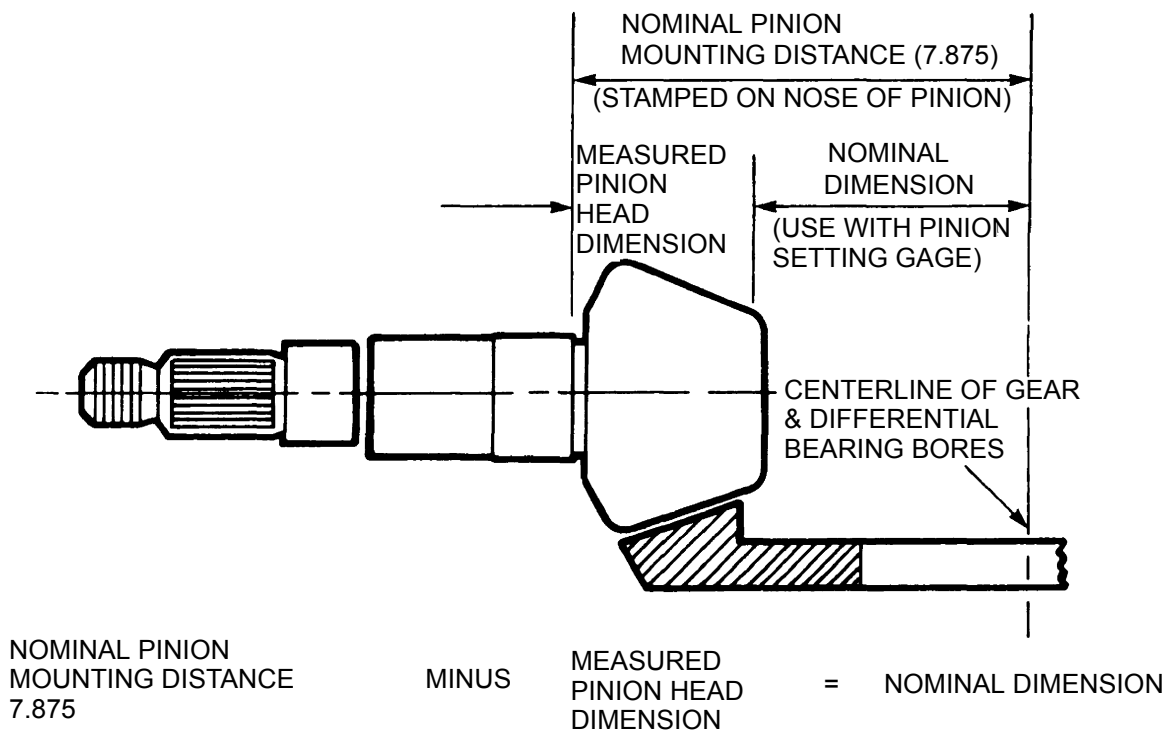

402-711

Figure 2. Establish Nominal Dimension.

- (4) Measure the length of the pinion head. Measure this distance from the nose to the bearing shoulder using a 3-4 in. micrometer or vernier.
- (5) Mark the spot on the pinion nose from which the head length measurement was taken. Later, when using the pinion setting gage, measure to the same spot.
- (6) Subtract the measured pinion head length from the nominal pinion mounting distance noted in step (3). The remainder is the nominal or gaging distance used for calculations when using the pinion setting gage. See figure 52 for the formula.
- (7) Continue with procedures using the calculated nominal (gaging) distance and the plus or minus PC variation.

**DIFFERENTIAL CARRIER ASSEMBLY - CONTINUED**e. **Assemble the Differential and Gear.****CAUTION**

The ring gear should not be pressed or driven on the case, as this would cause excessive metal particles to lodge between the gear and case, thus resulting in gear run-out. Proper installation should, therefore, incorporate preheating the gear to assure correct interference fit and to eliminate metal pickup.

- (1) Heat the ring gear (8) in oil to approximately 160°F-180°F (71.1°C-82.2°C) for about ten minutes before assembly.
  - (2) Install twelve new bolts, washers, and nuts. Torque to 180-230 lb-ft (244-312 Nm).
  - (3) Pre-lubricate the differential case inner walls and all component parts with the recommended axle lubricant.
  - (4) Position the thrust washer (5) and side gear (6) in the gear case (10) half.
  - (5) Place the spider (7) with pinions (23) and thrust washers (22) in position.
  - (6) Install the second side gear (6) and thrust washer (5).
  - (7) Position the other case (4) half over the assembly, aligning match marks of both halves. Draw the assembly together with three equally spaced washers (3) and capscrews (2).
  - (8) Install the remaining washers (3) and capscrews (2 and 24) and torque to 85-115 lb-ft (115-156 Nm).
  - (9) If new bearings are to be used, press squarely and firmly on the differential case halves with a suitable sleeve.
- f. **Rolling Resistance of Differential Nest.**
- (1) Place the differential and ring gear (8) assembly in a vise with soft metal jaws.
  - (2) Insert a checking tool (made from a splined axle shaft end) into the differential nest (fig. 3). Allow the splines of the tool to engage with the spline of one side gear (6) only.

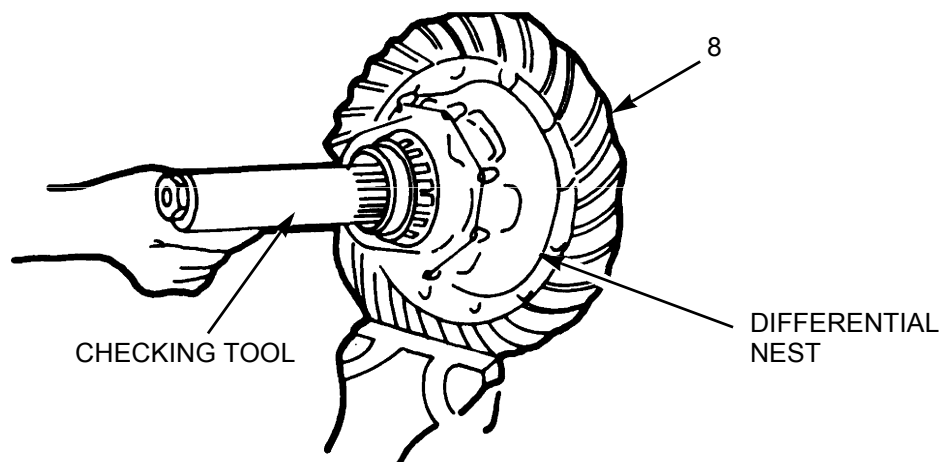

402-712

Figure 3. Install the Checking Tool.



**DIFFERENTIAL CARRIER ASSEMBLY - CONTINUED**

- (3) Using a suitable socket and torque wrench, rotate the differential nest while observing the scale on the torque wrench (fig. 4). Correct rolling resistance of the differential assembly is 50 lb-ft (68 Nm) torque maximum applied to one side gear.

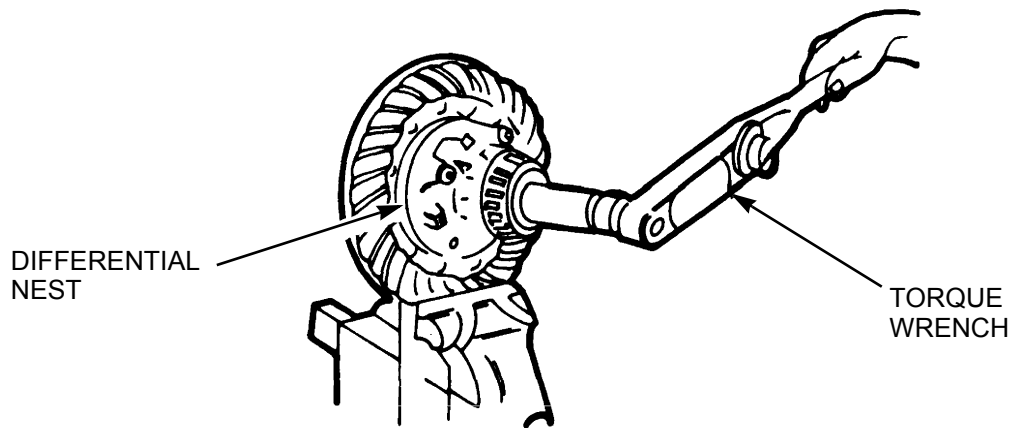

Figure 4. Check Rolling Resistance.

**g. Install the Differential and Gear Assembly.**

- (1) Install oil fill plug (16).
- (2) Pre-lubricate the differential bearings and cups with gear lube (Item 33, WP 0312 00).
- (3) Place the cups over the bearings and position the assembly in the carrier housing (15),
- (4) Insert the bearing adjusting rings (20) and turn hand-tight against bearings (1).

**CAUTION**

If bearing caps do not position properly, adjusting rings might be cross-threaded. Remove caps and reposition the adjusting rings. Forcing the caps into position will result in irreparable damage to the carrier housing or bearing caps.

- (5) Install the bearing caps (17) in the correct location as marked and tap lightly into position.
  - (6) Install the carrier leg capscrews (19) and washers (18) and torque to 290-350 lb-ft (393-475 Nm). Install adjusting rings (20), dowel, and cotter keys (21) after final adjustments are made.
- h. Adjust the Differential Bearing Preload.**
- (1) Using a dial indicator at the back face of the gear, loosen the bearing adjusting ring (20) on the side opposite gear only sufficient to notice end play on the indicator.
  - (2) Tighten the same adjusting ring (20) only sufficient to obtain 0.000 end play.
  - (3) Check the gear for run-out. If run-out exceeds 0.008 in. (0.203 mm), remove the differential and check for cause.
  - (4) Starting with 0.000 end play, tighten each adjusting ring (20) one notch. This will properly preload the differential bearing.

**DIFFERENTIAL CARRIER ASSEMBLY - CONTINUED**i. **Check the Amboid Gear Backlash.**

- (1) If the ring gear is being replaced, the established backlash recorded before disassembly will be used. For new gears, the new backlash should be initially set at 0.015 in. (0.381 mm).
- (2) Adjust backlash by moving the gear only. This is done by backing off one adjusting ring and advancing the opposite ring the same amount. Use a dial indicator mounted on the carrier-to-housing flange with the indicator pointer against one ring gear tooth.

j. **Check the Tooth Contact.**

- (1) Refer to paragraph WP 0257 00 for checking procedure.
- (2) With adjustments properly made (pinion at correct depth and backlash set at 0.015 in. (0.38 mm), the contact in figure 5 will be procured. The area of contact is at the toe and is centered between the top and bottom of the tooth.

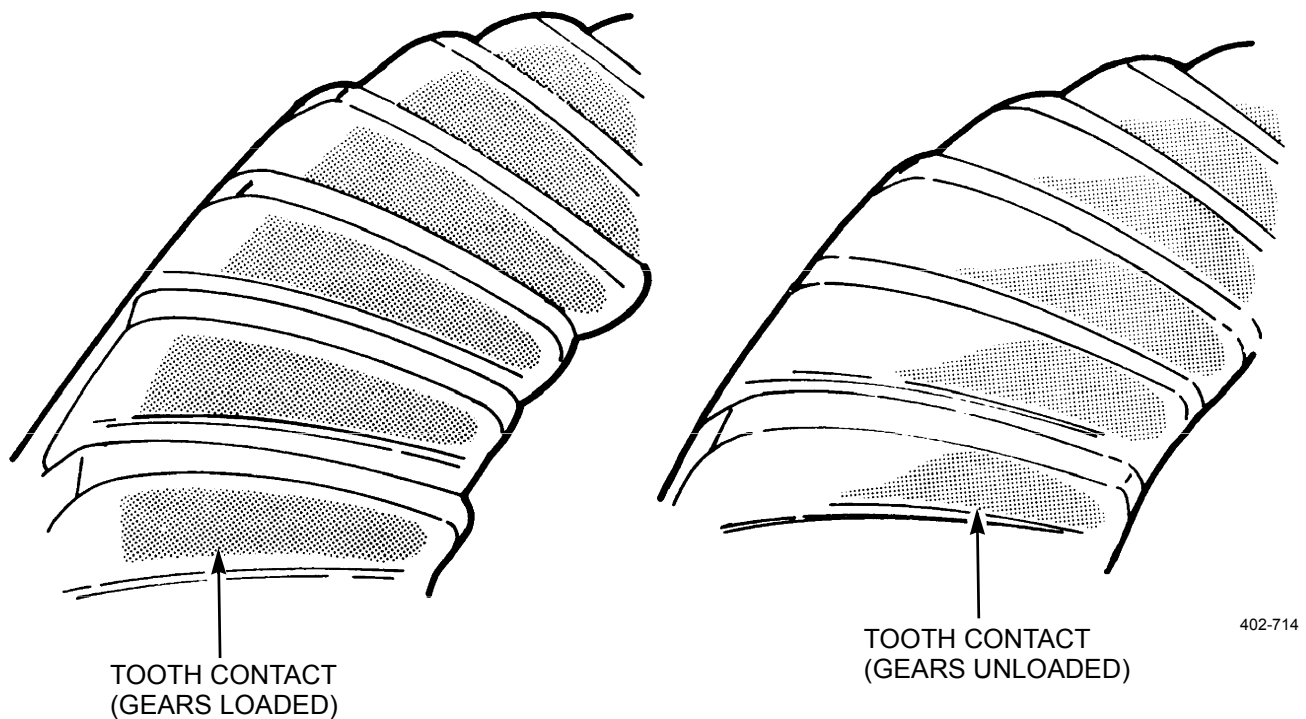

Figure 5. Satisfactory Amboid Tooth Contact.

- (3) The hand-rolled pattern shown (gears unloaded) will result in a pattern centered in the length of the tooth when the gears are under load. The loaded pattern will be almost full length and the top of pattern will approach the top of the gear tooth.
- (4) If facilities are available for applying approximately 200 lb-ft (271 Nm) of torque or more to the pinion shaft, the following final check of tooth contacts is suggested.

**DIFFERENTIAL CARRIER ASSEMBLY - CONTINUED****NOTE**

The pattern on the coast side of teeth will appear the same width as the drive side.

- (5) After the correct contacts (shown above) have been established with a backlash of 0.015 in. (0.381 mm) open backlash to measure between 0.008-0.020 in. (0.203-0.508 mm) if required.
- (6) Set used gear to have the tooth contacts match wear patterns. Hand-rolled patterns of used gears will be smaller in area and should be at the toe end of wear patterns. Incorrect patterns are shown in figure 6.

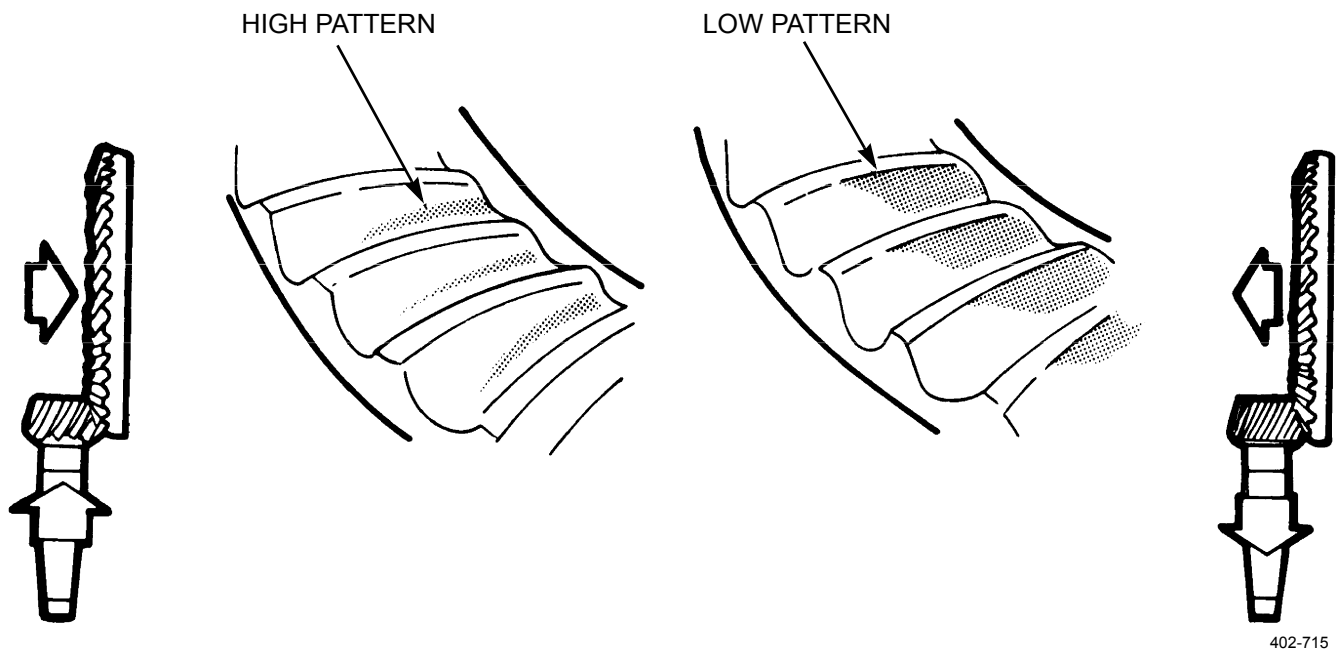

Figure 6. Incorrect Contact Patterns.

k. **Install the Thrust Block.**

- (1) Remove the carrier from the stand and position with the back face of ring gear upward.
- (2) Remove the adjusting screw (13) and locknut (14).
- (3) Place the thrust block (9) on the rear face of the gear and rotate the gear until the hole in the thrust block is aligned with the adjusting screw hole.
- (4) Install the adjusting screw (13) and locknut (14) and tighten adjusting screw sufficiently to locate the thrust block (9) firmly against the back face of gear.
- (5) To secure the correct adjustment of 0.010-0.015 inch (0.254-0.381 mm) clearance, loosen adjusting screw (13) ¼ turn and lock securely with nut (14). Torque nut to 150-190 lb-ft (203-258 Nm).
- (6) Recheck to assure clearance of 0.010-0.015 inch during full rotation of gear.

**END OF WORK PACKAGE**



**REAR YOKE AND OIL SEAL REPLACEMENT**

**0260 00**

**THIS WORK PACKAGE COVERS**

Removal, Installation

**INITIAL SETUP**

**Maintenance Level**

Direct Support

**Tools and Special Tools**

Tool kit, general mechanic's (Item 102, WP 0313 00)

Wrench, torque, 100-600 lb-ft (Item 112, WP 0313 00)

**Materials/Parts**

Oil, lubricating (Item 33, WP 0312 00)

**Materials/Parts - Continued**

Seal (P/N A-1205-B-1328)

Nut, flanged (P/N 1227K1051)

**Personnel Required**

Two

**Equipment Condition**

Driveline removed (WP 0116 00)

Axle oil drained (WP 0120 00)

**REMOVAL**

1. Using yoke holder bar, remove flanged nut (4) and yoke (3) from differential shaft (1). Discard flanged nut.
2. Remove oil seal (2) from differential shaft (1). Discard oil seal.

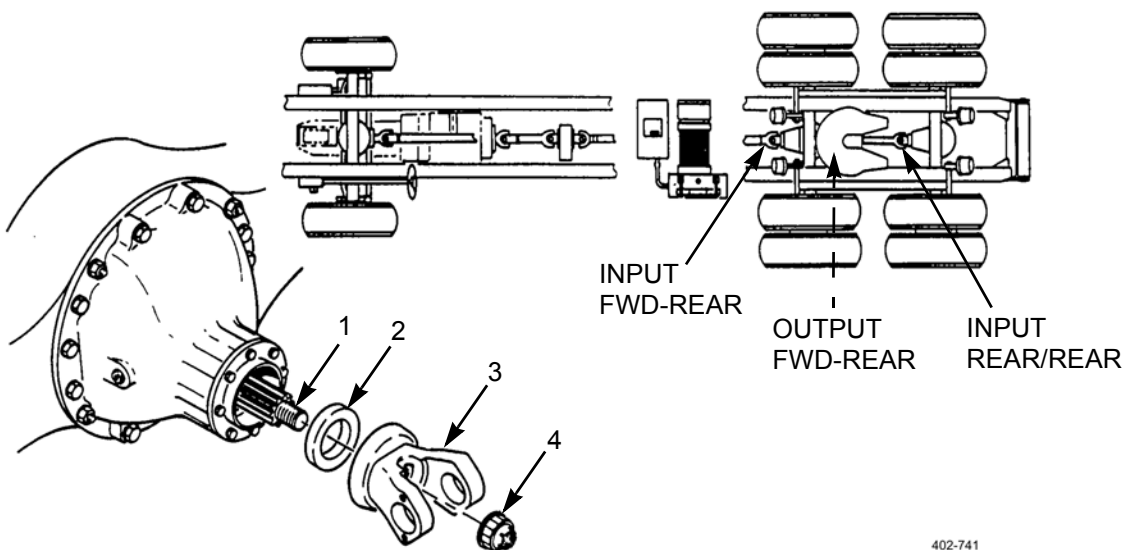

402-741

**REAR YOKE AND OIL SEAL REPLACEMENT - CONTINUED****0260 00****INSTALLATION**

1. Apply lubricating oil to new oil seal (2) and install oil seal to differential shaft (1).
2. Install yoke (3) on differential shaft (1).
3. Using yoke holder bar, install new flanged nut (4) on differential shaft (1).
4. Tighten nut to 450-600 lb-ft (610-814 Nm) on input FWD-rear and output FWD-rear, and tighten to 1000-1230 lb-ft (1356-1668 Nm) on input rear-rear.

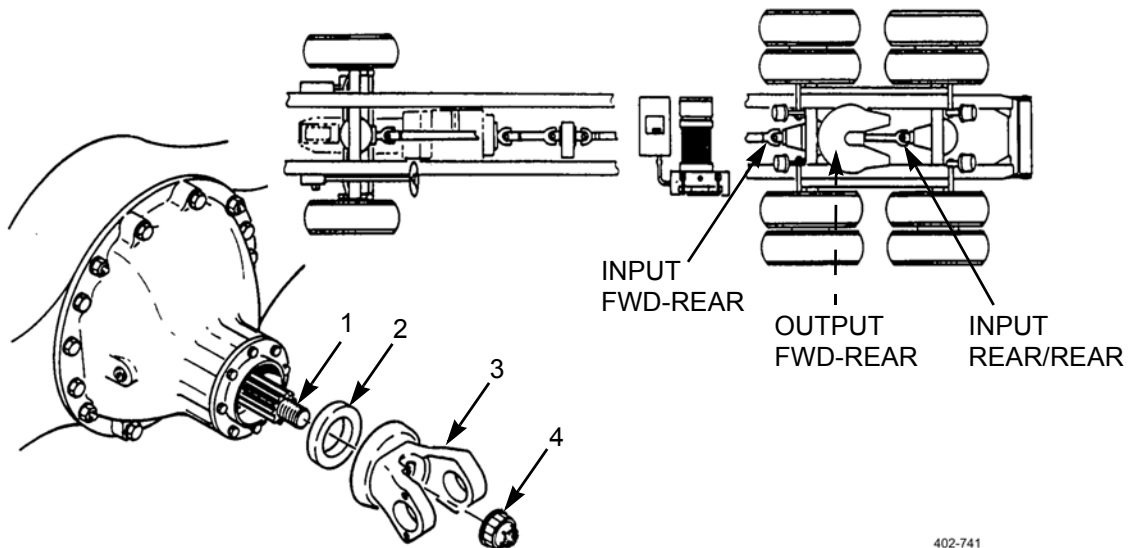

5. Install driveline (WP 0116 00).
6. Fill axle with oil (WP 0120 00).

**END OF WORK PACKAGE**

402-741

---

**FOOT BRAKE VALVE REPAIR****0261 00**

---

**THIS WORK PACKAGE COVERS**Disassembly, Assembly

---

**INITIAL SETUP****Maintenance Level**

Direct Support

**Tools and Special Tools**

Tool kit, general mechanic's (Item 102, WP 0313 00)

Caps, vise jaw (Item 10, WP 0313 00)

Vise, machinist's (Item 106, WP 0313 00)

**Materials/Parts**

Grease, aircraft (Item 22, WP 0312 00)

Kit, repair (P/N 82TV196)

**Equipment Condition**Foot brake valve removed (WP 0146 00)

---

**DISASSEMBLY****NOTE**

- To assist in disassembly, place foot brake valve in a soft-jawed vise.
- Discard all components of repair kit.

**DISASSEMBLY - CONTINUED**

1. Remove screw (6), washer (5), and diaphragm (4) from cover (3).
2. Remove four screws (7), washers (8), and cover (3) from lower body (1).
3. Remove valve (2) assembly from lower body (1).

**NOTE**

Perform steps 4 and 5 to disassemble valve assembly.

4. While holding valve (2) assembly in collapsed position, remove retaining ring (12) from valve.
5. Release washer (13) and remove washer, retainer (14), spring (15), and seat (9) from valve (2). Remove two preformed packings (10 and 11) from retainer.

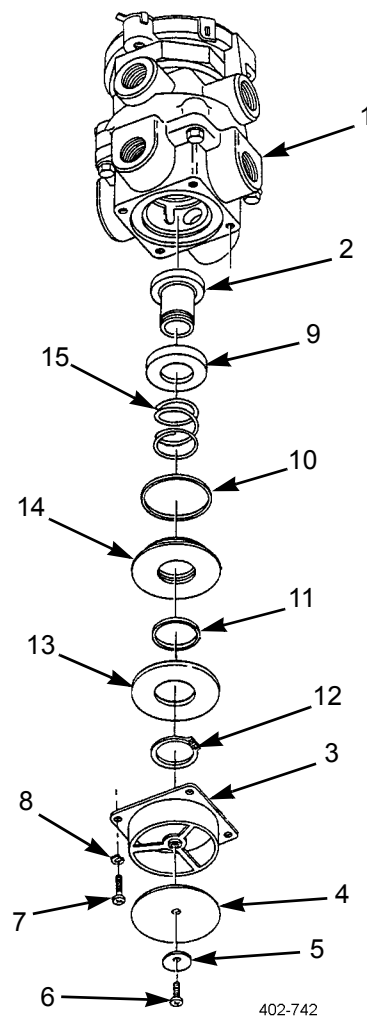

402-742



**DISASSEMBLY - CONTINUED**

6. Remove four screws (19), washers (20), and lower body (1) from upper body (17). Remove preformed packing (18) from lower body.
7. Remove primary piston retainer (16) from upper body (17).

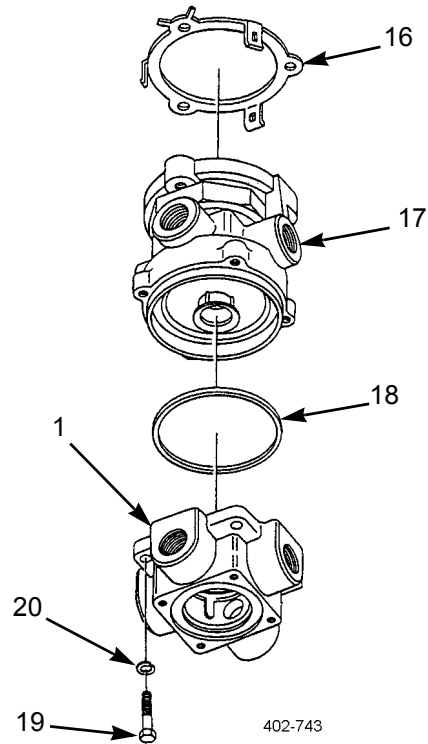

402-743

**DISASSEMBLY - CONTINUED****WARNING**

Internal components are under spring pressure. Use care when disassembling. Failure to hold components in position may result in injury to personnel.

8. While holding primary piston (25) and piston (28) in position in upper body (17), use a screwdriver in head of screw (29) to prevent screw from turning.
9. Remove locknut (32), retainer (21), and spring (22) from screw (29). Remove screwdriver and gradually release primary piston (25) and piston (28).
10. Remove primary piston (25) and spring (27) from upper body (17). Remove preformed packing (26) and rubber washer (30) from primary piston.
11. Remove sleeve nut (31), spring seat (23), and rubber spring (24) from primary piston (25).

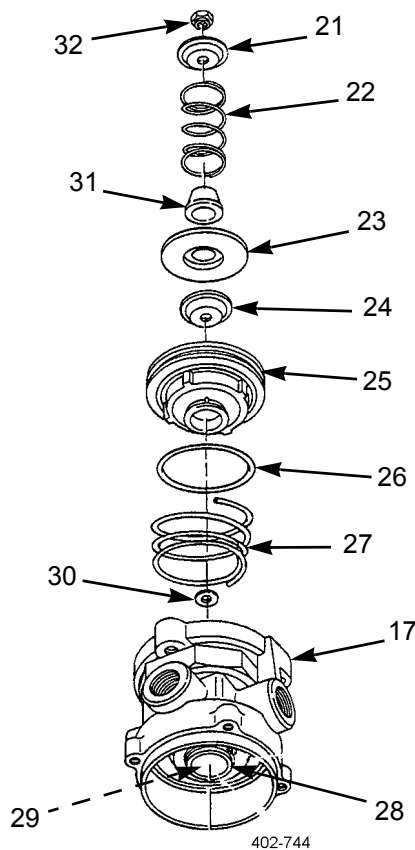

12. Remove screw (29), piston (28), spring (39), and retainer (40) from upper body (17). Remove two preformed packings (37 and 38) from piston.

**NOTE**

Step 13 removes valve assembly from upper body.

13. Remove retaining ring (42), retaining clip (41), washer (43), retainer (36), preformed packing (44), spring (35), seat (34), and valve (33) from upper body (17).

**DISASSEMBLY - CONTINUED**

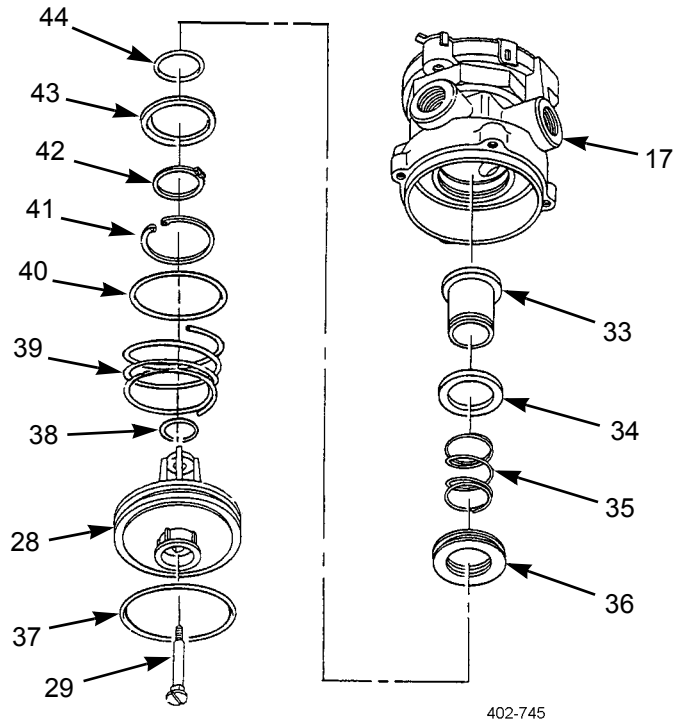

**ASSEMBLY**

**NOTE**

- To assist in assembly, place foot brake valve in a soft-jawed vise.
- Install new repair kit parts on assembly.

1. Apply a light coating of grease to surfaces of preformed packings, preformed packing grooves and piston bores of upper body (17).

**NOTE**

Perform step 2 to install valve assembly to upper body.

2. Install valve (33), seat (34), spring (35), preformed packing (44), retainer (36), washer (43), and retaining clip (41) to upper body (17) with retaining ring (42).
3. Install two preformed packings (37 and 38) to piston (28). Install retainer (40), spring (39), piston (28), and screw (29) to upper body (17).

**ASSEMBLY - CONTINUED**

4. Install rubber spring (24) and spring seat (23) to primary piston (25) with sleeve nut (31).
5. Install rubber washer (30) and preformed packing (26) to primary piston (25). Install spring (27) and primary piston to upper body (17).

**WARNING**

Internal components are under spring pressure. Use care when assembling. Failure to hold components in position may result in injury to personnel.

6. While holding primary piston (25) and piston (28) compressed, and using a screwdriver to prevent screw (29) from turning, install spring (22) and retainer (21) to screw with locknut (32).

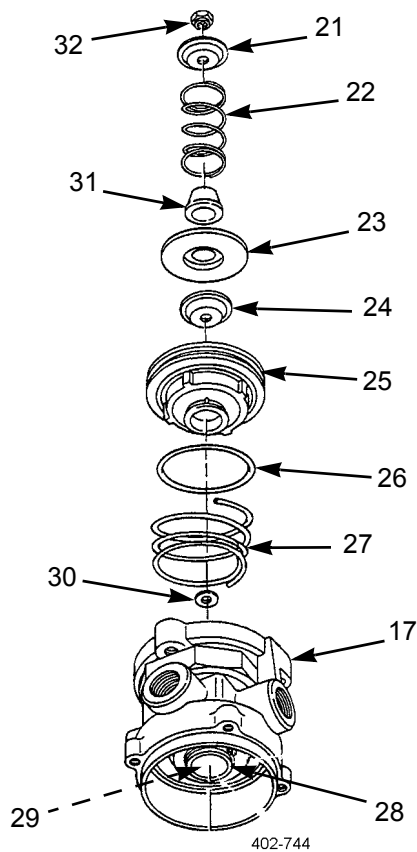

**ASSEMBLY - CONTINUED**

7. Install primary piston retainer (16) to upper body (17).
8. Install preformed packing (18) to lower body (1) and install lower body to upper body (17) with four washers (20) and screws (19).

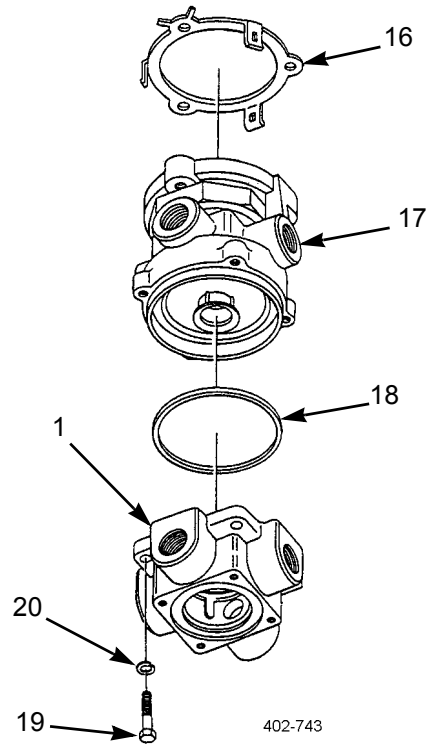

402-743

**ASSEMBLY - CONTINUED**

9. Install two preformed packings (10 and 11) to retainer (14) and install seat (9), spring (15), retainer, and washer (13) to valve (2) with retaining ring (12).
10. Install valve (2) assembly to lower body (1).
11. Install cover (3) to lower body (1) with four washers (8) and screws (7).
12. Install diaphragm (4) to cover (3) with washer (5) and screw (6).

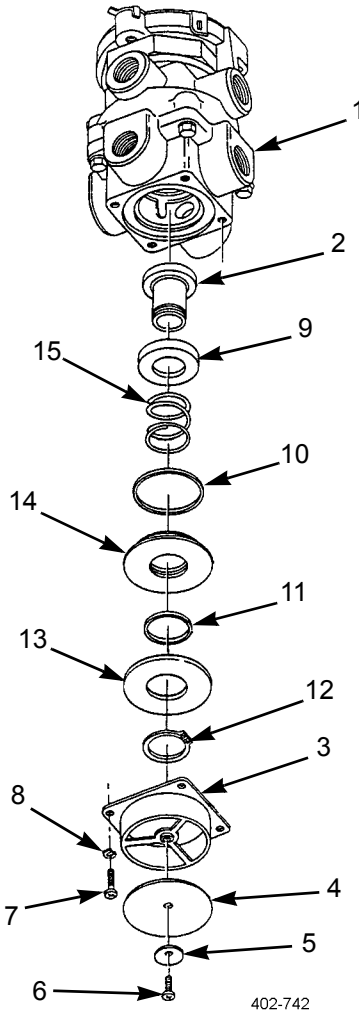

13. Install foot brake valve (WP 0146 00).

**END OF WORK PACKAGE**

---

**AIR DRYER REPAIR**

---

0262 00

**THIS WORK PACKAGE COVERS**

Disassembly, Inspection, Assembly

---

**INITIAL SETUP****Maintenance Level**

Direct Support

**Tools and Special Tools**

Tool kit, general mechanic's (Item 102, WP 0313 00)

Wrench, strap (Item 107, WP 0313 00)

Wrench, torque, 0-300 lb-in (Item 109, WP 0313 00)

Wrench, torque, 15-75 lb-ft (Item 110, WP 0313 00)

**Materials/Parts**

Grease, GAA (Item 23, WP 0312 00)

Oil, lubricating (Item 27, WP 0312 00)

Canister, air dryer (P/N R950011)

Kit, valve, turbo cut-off (P/N R950013)

Kit, valve, purge (P/N R950014)

Kit, valve, outlet check (P/N R950017)

Kit, heater (P/N R950015)

**Equipment Condition**

Air dryer removed (WP 0134 00)

---

**DISASSEMBLY**

1. Use strap wrench to remove air dryer canister (1) from air dryer (3). Discard canister.
2. Remove O-ring (2) from air dryer (3). Discard O-ring.

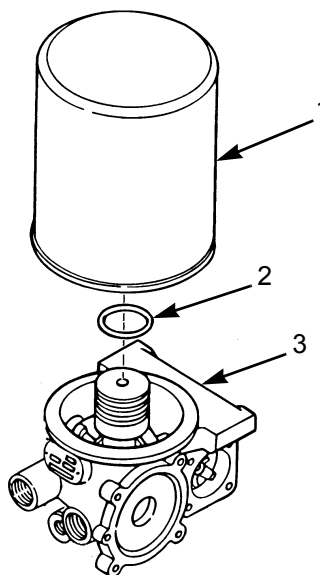

402-762

**DISASSEMBLY - CONTINUED****NOTE**

Perform steps 3 through 5 to remove REGENERATION VALVE ASSEMBLY.

3. Remove four screws (8), housing (7), spring (6), and cap (5) from air dryer (3).
4. Remove rubber diaphragm (4) from air dryer (3).
5. Remove O-ring (10) and filter (9) from housing (7). Discard O-ring.

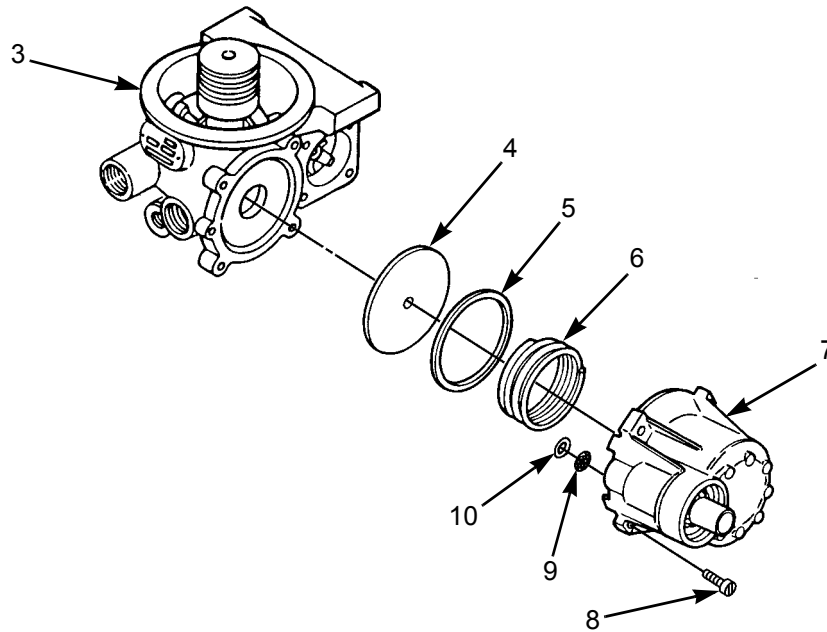

402-763



**DISASSEMBLY - CONTINUED****NOTE**

Perform steps 6 through 9 to remove TURBO CUT-OFF VALVE ASSEMBLY.

6. Remove rubber plug (17) from cover (15).

**NOTE**

A wooden stick may be used to push cover, spring, and piston out from air dryer.

7. Remove retaining ring (16), cover (15), spring (13), and piston (12) from air dryer (3).
8. Remove O-ring (14) from cover (15). Discard O-ring.

**NOTE**

Note position of seal on piston for assembly.

9. Remove seal (11) from piston (12). Discard seal.

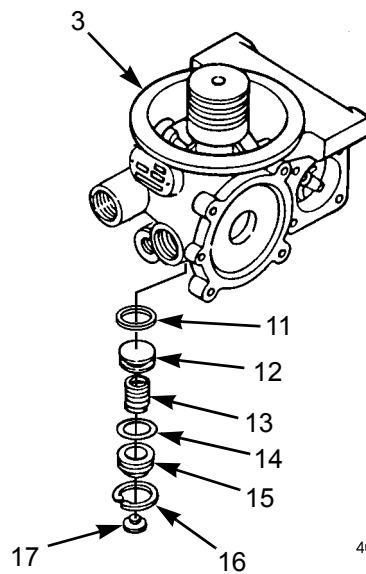

402-764

**DISASSEMBLY - CONTINUED****NOTE**

Perform steps 10 through 14 to remove PURGE VALVE ASSEMBLY.

10. Remove retaining ring (25) and valve head (24) from air dryer (3).

**NOTE**

Two shims, one at each end of spring, will be removed if equipped.

11. Remove spring (26), two shims (22), and O-ring (23) from valve head (24). Discard O-ring.
12. Remove piston (27) and piston seat (21) from air dryer (3).
13. Remove O-ring (20) from piston (27). Discard O-ring.

**NOTE**

Note position of washer for installation.

14. Remove washer (19) and O-ring (18) from air dryer (3). Discard O-ring.

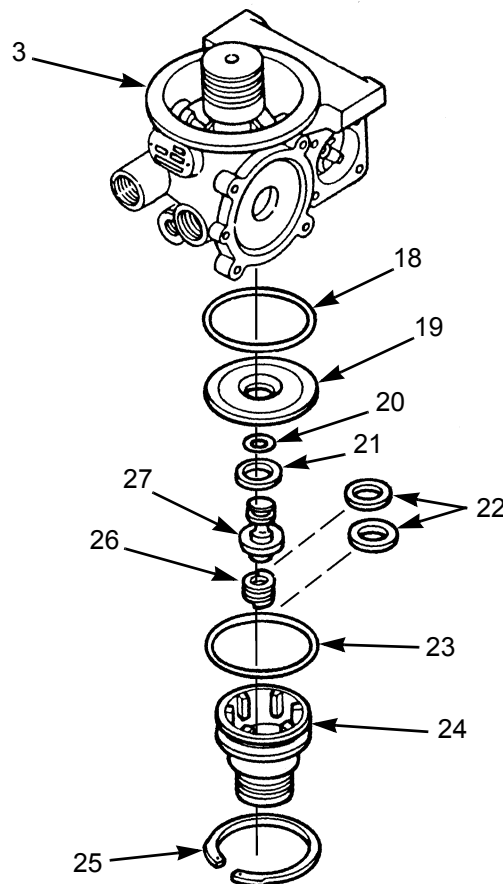

402-765

**DISASSEMBLY - CONTINUED****NOTE**

Perform steps 15 and 16 to remove OUTLET CHECK VALVE ASSEMBLY.

15. Remove retaining ring (32), washer (31), spring (30) and valve body (29) from outlet port of air dryer (3).
16. Remove O-ring (28) from valve body (29). Discard O-ring.

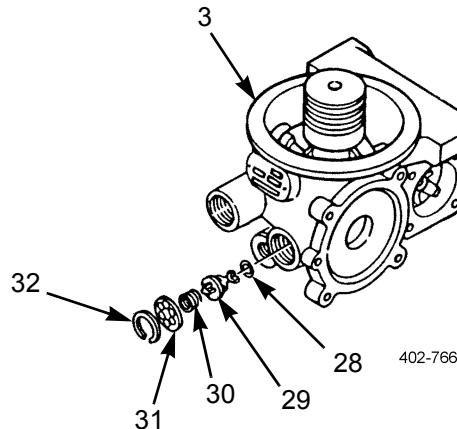
**NOTE**

Perform steps 17 through 22 to remove HEATER ASSEMBLY.

17. Remove two screws (33) and pull connector (34) outward from air dryer (3).
18. Disconnect wire (42) and heater wire (36) from connector (34).
19. Remove O-ring (35) from connector (34). Discard O-ring.
20. Remove screw (41) and thermostat retainer (40) from air dryer (3).
21. Remove thermostat (38) and heater element (39) from air dryer (3).
22. Disconnect wire (42) and heater wire (37) from thermostat (38).

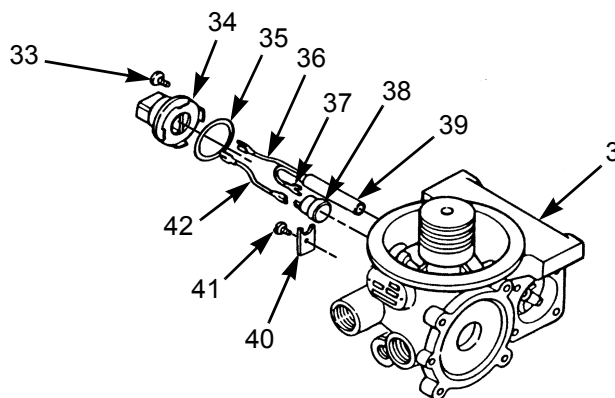

**DISASSEMBLY - CONTINUED****NOTE**

Perform step 23 to remove PRESSURE RELIEF VALVE.

23. Remove pressure relief valve (43) from air dryer (3).

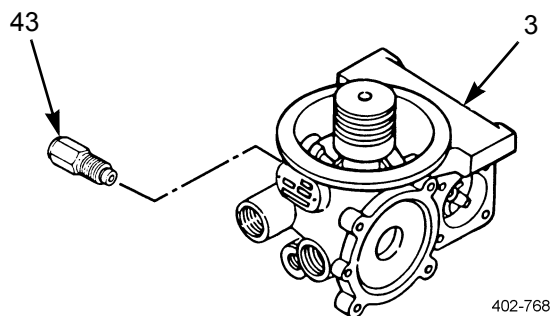
**INSPECTION**

Inspect valve bores in air dryer for wear and damage. If wear or damage is found that would prevent a tight seal with valve components, replace air dryer.

**ASSEMBLY****NOTE**

- Lubricate all O-rings and seals with grease included in parts kit prior to installing.
  - Perform step 1 to install PRESSURE RELIEF VALVE.
  - Pipe threads of new pressure relief valve are already coated with sealant. Additional sealant is not required.
1. Install pressure relief valve (43) to air dryer (3). Tighten pressure relief valve to no greater than 30 lb-ft (41 Nm).

**NOTE**

Perform steps 2 through 7 to install HEATER ASSEMBLY.

2. Connect heater wire (37) and wire (42) to thermostat (38).
3. Position heater element (39) and thermostat (38) into air dryer (3).
4. Install thermostat retainer (40) to air dryer (3) with screw (41).
5. Install new O-ring (35) to connector (34).
6. Connect heater wire (36) and wire (42) to connector (34).
7. Push connector (34) into air dryer (3) and install two screws (33).

ASSEMBLY - CONTINUED

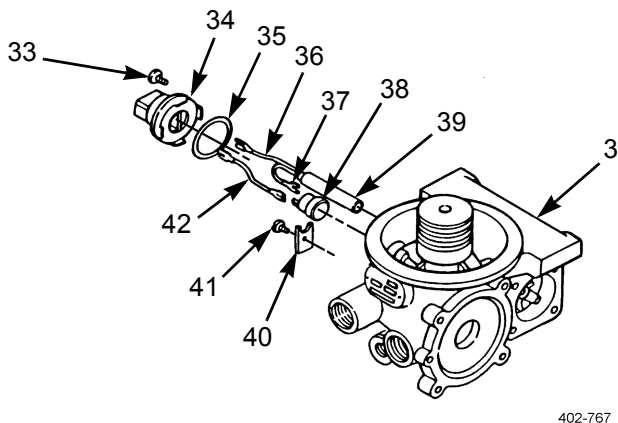

402-767

**NOTE**

Perform steps 8 through 10 to install OUTLET CHECK VALVE ASSEMBLY.

8. Apply a thin coat of grease to bore of air dryer (3) and new O-ring (28).
9. Install O-ring (28) to valve body (29).
10. Install valve body (29), spring (30), and washer (31) to outlet port of air dryer (3) with retaining ring (32).

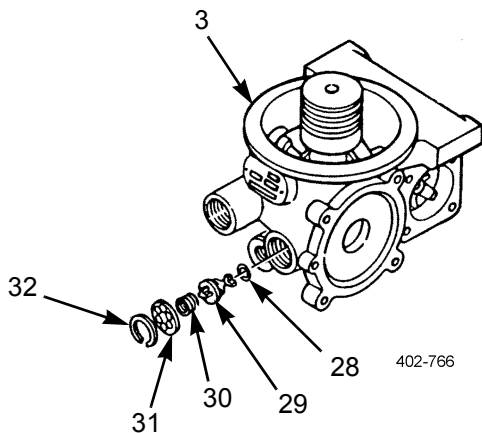

402-766

**ASSEMBLY - CONTINUED****NOTE**

Perform steps 11 through 17 to install PURGE VALVE ASSEMBLY.

11. Apply a thin coat of grease to bore of air dryer (3) and three O-rings (18, 20, and 23).
12. Install O-ring (18) to air dryer (3).

**NOTE**

Lip of washer must face piston seat.

13. Install piston seat (21), O-ring (20), and washer (19) to piston (27).
14. Install piston (27) assembly into air dryer (3).
15. Install O-ring (23) to valve head (24).

**NOTE**

If equipped, also install two shims. One shim at each end of spring.

16. Install spring (26) and two shims (22) to valve head (24).
17. Install valve head (24) to air dryer (3) with retaining ring (25).

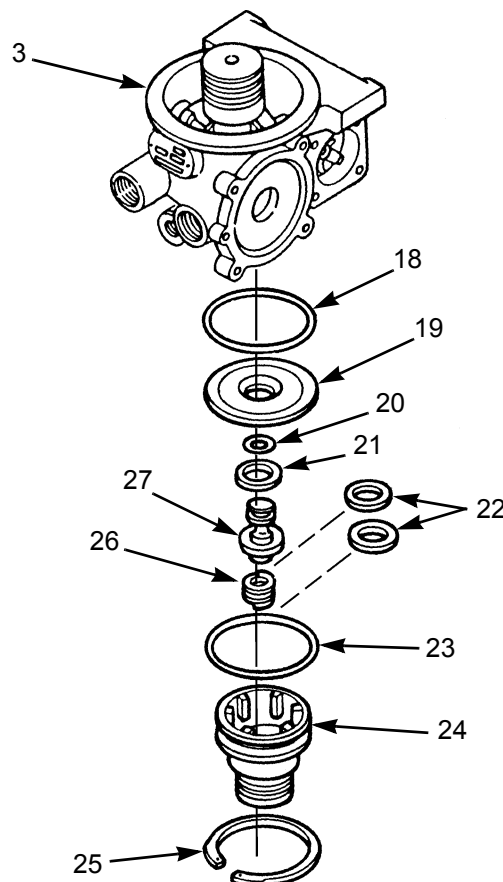

402-765

**ASSEMBLY - CONTINUED****NOTE**

Perform steps 18 through 22 to install TURBO CUT-OFF VALVE ASSEMBLY.

18. Apply thin coat of grease to bore of air dryer (3), new O-ring (14) and new seal (11).
19. Install seal (11) to piston (12) with lip of seal facing top of piston.
20. Install O-ring (14) to cover (15).
21. Install piston (12), spring (13), and cover (15) to air dryer (3) with retaining ring (16).
22. Install rubber plug (17) to cover (15).

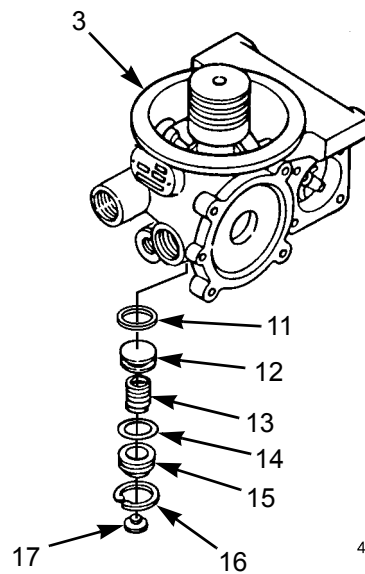

402-764

**ASSEMBLY - CONTINUED****NOTE**

Perform steps 23 through 26 to install REGENERATION VALVE ASSEMBLY.

23. Apply thin coat of grease to new O-ring (10).
24. Install filter (9) and O-ring (10) to housing (7).
25. Position rubber diaphragm (4) to air dryer (3) with lip of diaphragm in groove of air dryer. Do not apply grease.
26. With lip of cap (5) facing away from air dryer (3), install cap, spring (6), and housing (7) with four screws (8). Tighten screws to 53 lb-in (6 Nm).

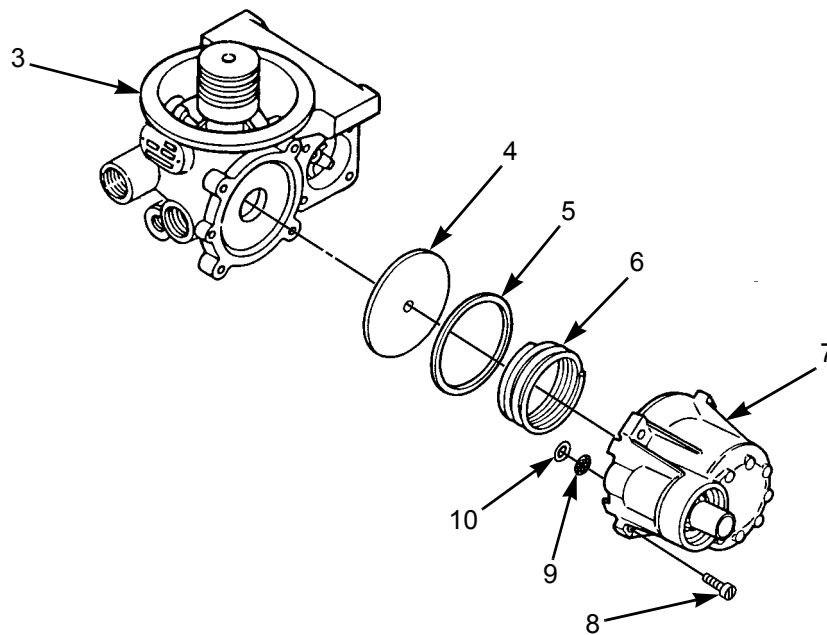

402-763



**ASSEMBLY - CONTINUED****NOTE**

New air dryer canister comes with a new O-ring.

27. Apply a thin coat of oil to new O-ring (2) and install O-ring to top of air dryer (3).
28. Apply a thin coat of oil to rubber seal of new air dryer canister (1).
29. Install air dryer canister (1) to air dryer (3) until rubber seal contacts surface of air dryer. Rotate canister in additional ONE full turn.

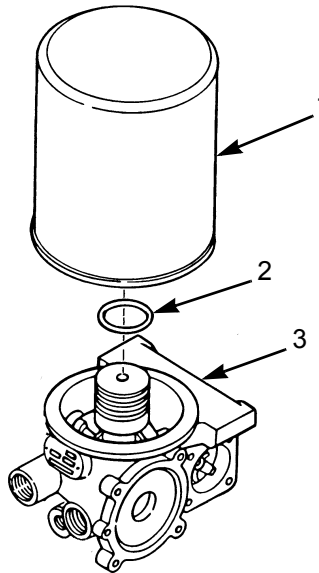

402-762

30. Install air dryer (WP 0134 00).

**END OF WORK PACKAGE**



**BRAKE DRUM REPAIR**

**0263 00**

**THIS WORK PACKAGE COVERS**

Repair

**INITIAL SETUP**

**Maintenance Level**

Direct Support

**Materials/Parts**

Cloth, abrasive (Item 10, WP 0312 00)

**Tools and Special Tools**

Tool kit, general mechanic's (Item 102, WP 0313 00)

Lathe, brakedrum (Item 53, WP 0313 00)

**Equipment Condition**

Brakedrum removed from vehicle (WP 0154 00 or WP 0155 00)

**REPAIR**

**CAUTION**

If maximum inside diameter is exceeded, to prevent damage to equipment, brake drum must be replaced.

1. Check brake drum inside diameter. Refer to Table 1 for diameter.
2. Brake drum (1) must be round within 0.003 in (0.076 mm). If brake drum is out-of-round, machine brake drum. Refer to Table 1 for machining specifications.

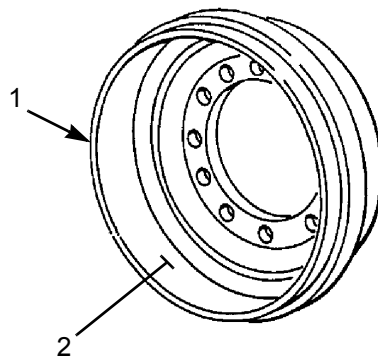

402-769

3. Check brake drum surface (2) for cracks or badly scored finish. If brake drum is cracked or scored, machine brake drum. Refer to Table 1 for machining specifications.
4. Check brake drum surface (2) for glossy or heat spots. If glossy or heat spots are visible, clean brake drum surface with abrasive cloth.
5. Check brake drum (1) for external or mating surface cracks. If cracks are visible, replace brake drum.
6. Check brake drum (1) for balance weight. If balance weight is missing, replace brake drum.

**REPAIR - CONTINUED****Table 1. Machining Specifications.**

	<b>Inside Diameter (new) in (mm)</b>	<b>Machine Brake Drum in (mm)</b>	<b>Maximum Inside Diameter in (mm)</b>
<b>FRONT</b>	15.0 (381.0)	0.12 (4.00)	15.12 (384.00)
<b>REAR</b>	16.5 (419.1)	0.12 (4.00)	16.62 (422.15)

7. Install brake drum (WP 0154 00 or WP 0155 00).

**END OF WORK PACKAGE**

**POWER STEERING PUMP REPLACEMENT**

**0264 00**

**THIS WORK PACKAGE COVERS**

Removal, Installation

**INITIAL SETUP**

**Maintenance Level**

Direct Support

**Tool and Special Tools**

Tool kit, general mechanic's (Item 102, WP 0313 00)

Shop equipment, automotive (Item 81, WP 0313 00)

**Materials/Parts**

Cap and plug set (Item 8, WP 0312 00)

Oil, lubricating (Item 27, WP 0312 00)

Gasket (P/N 154916)

**Equipment Condition**

Power steering reservoir drained (WP 0024 00)

**REMOVAL**

1. Loosen hose clamp (8) from elbow (9) at bottom of power steering pump (1). Disconnect inlet hose (7) from elbow and plug end of hose.
2. Disconnect outlet hose (11) from elbow (10) at side of power steering pump (1). Plug end of hose.
3. Remove two screws (5), lockwashers (6), power steering pump (1), coupling (3), flex shaft coupling (4), and gasket (2) from front of engine. Discard lockwashers and gasket.

**NOTE**

Note position of elbows for installation.

4. Remove two elbows (9 and 10) from power steering pump (1).

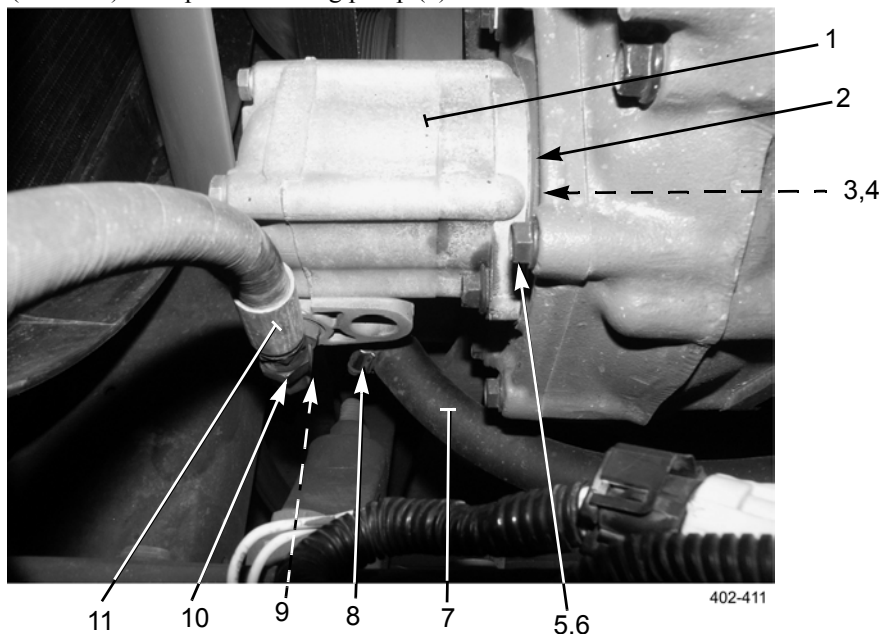

**POWER STEERING PUMP REPLACEMENT - CONTINUED****0264 00****INSTALLATION**

1. Install two elbows (9 and 10) to power steering pump (1).
2. Apply a coat of oil to shaft of power steering pump (1) and both sides of new gasket (2).
3. Install new gasket (2), flex shaft coupling (4), coupling (3), and power steering pump (1) to front of engine with two new lockwashers (6) and screws (5). Tighten screws to 35 lb-ft (46 Nm).
4. Remove plug and connect outlet hose (11) to elbow (10) at side of power steering pump (1).
5. Remove plug and connect inlet hose (7) to elbow (9) at bottom of power steering pump (1). Tighten hose clamp (8).

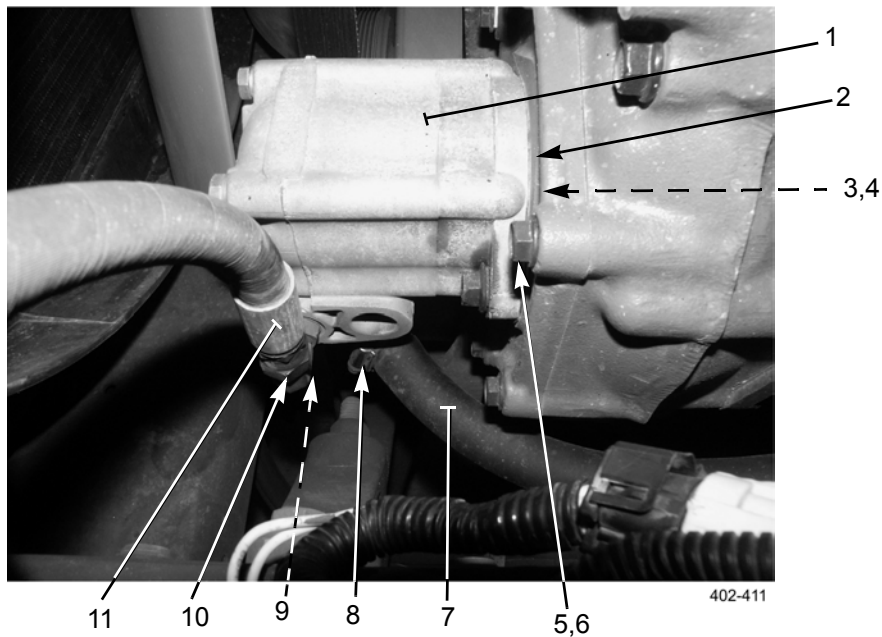

6. Fill power steering system (WP 0024 00).

**END OF WORK PACKAGE**

---

**STEERING GEAR REPLACEMENT (M915A4)**

**0265 00**

---

**THIS WORK PACKAGE COVERS**

Removal, Installation

---

**INITIAL SETUP**

**Maintenance Level**

Direct Support

**Tools and Special Tools**

Tool kit, general mechanic's (Item 102, WP 0313 00)

Shop equipment, automotive (Item 83, WP 0313 00)

Multiplier, torque wrench (Item 61, WP 0313 00)

**Materials/Parts - Continued**

Washer, lock (P/N MS35338-147)

**References**

WP 0024 00

**Equipment Condition**

Vehicle parked with wheels straight

Pitman arm and drag link removed (WP 0158 00)

Power steering reservoir drained (WP 0024 00)



**WARNING**

Spilled power steering fluid is very slippery. Wipe up any spilled fluid immediately. Failure to do so could result in serious injury to personnel.

**STEERING GEAR REPLACEMENT (M915A4) - CONTINUED****0265 00****REMOVAL**

1. Remove nut (6) and bolt (5) and disconnect lower universal shaft (8) from steering gear (14).

**NOTE**

Oil will be present when hoses are removed.

2. Tag and disconnect two hoses (7) from steering gear (14). Plug hoses.

**NOTE**

- Support steering gear during removal.
- Tag screw location during removal to aid in installation.

3. Remove two nuts (10), two washers (9), two screws (1), and two washers (2).
4. Remove screw (13), lockwasher (12), and steering gear (14). Discard lockwasher.
5. Remove elbow (4), tee (11), and two packings (3) from steering gear (14). Discard packings.

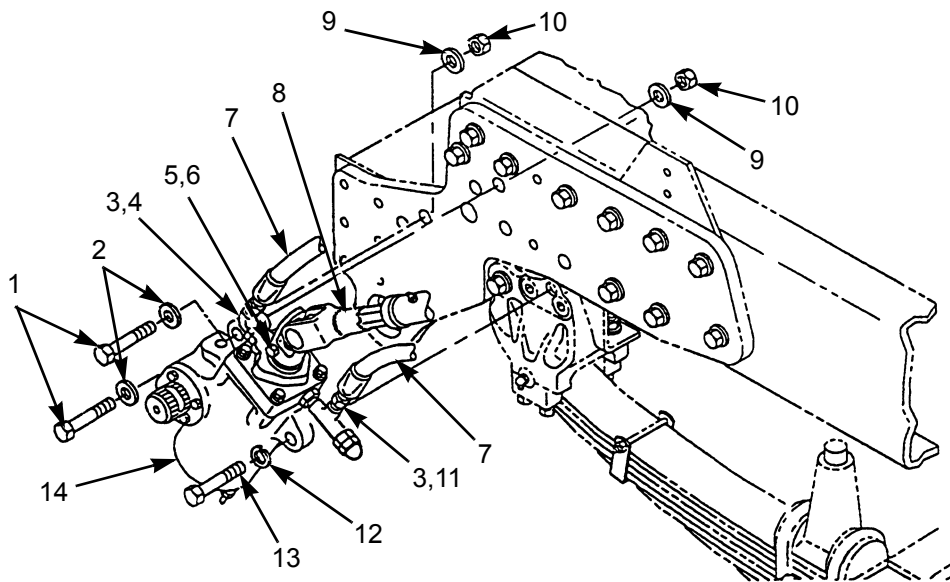

402-774

**INSTALLATION**

1. Install two new packings (3), tee (11), and elbow (4) on steering gear (14).

**NOTE**

Support steering gear during installation.

2. Install steering gear (14), new lockwasher (12), and screw (13).
3. Install two washers (2), two screws (1), two washers (9), and two nuts (10). Tighten locknuts to 344-466 lb-ft (466-632 Nm).



***INSTALLATION - CONTINUED*****WARNING**

Spilled power steering fluid is very slippery. Wipe up any spilled fluid immediately. Failure to do so could result in serious injury to personnel.

4. Remove plugs from two hoses (7) and connect two hoses (7) on steering gear (14).
5. Connect lower universal shaft (8) to steering gear (14) and install bolt (6) and new locknut (5).
6. Install pitman arm and drag link (WP 0158 00).
7. Fill power steering reservoir (WP 0024 00).

**END OF WORK PACKAGE**



**STEERING GEAR REPLACEMENT (M915A4R2)****0265 01****THIS WORK PACKAGE COVERS**

Removal, Installation

**INITIAL SETUP****Maintenance Level**

Direct Support

**Tools and Special Tool**

Tool kit, general mechanic's (Item 102, WP 0313 00)

Multiplier, torque wrench (Item 61, WP 0313 00)

Shop equipment, automotive (Item 83, WP 0313 00)

**Materials/Parts**

Oil, lubricating, HDO (Item 27, WP 0312 00)

Cap and plug set (Item 8, WP 0312 00)

**Materials/Parts - Continued**

Rags, wiping (Item 39, WP 0312 00)

Tags, marker (Item 42, WP 0312 00)

**Personnel Required**

Two

**References**

TM 9-2320-303-10

**Equipment Conditions**

Lower end of universal steering shaft disconnected (WP 0157 00)

Pitman arm and drag link removed (WP 0158 00)

Power steering reservoir drained (WP 0024 00)

**REMOVAL****NOTE**

Perform steps 1 through 5 before performing steering gear removal steps.

1. If operational, operate vehicle (TM 9-2320-303-10) and turn front wheels fully to the right until turning limit is reached. Stop vehicle.
2. Check that stop screw (2) just contacts axle stop (1). If necessary, loosen locknut (3) and adjust position of stop screw. Tighten locknut to 50-65 lb-ft (68-99 Nm).
3. Confirm a clearance of at least 1/2 in. (13 mm) between front tire and any part of chassis.
4. Repeat steps 1 through 3 except turn front wheels fully to the left.
5. Again operate vehicle to position vehicle in work area with front wheels facing straight ahead.

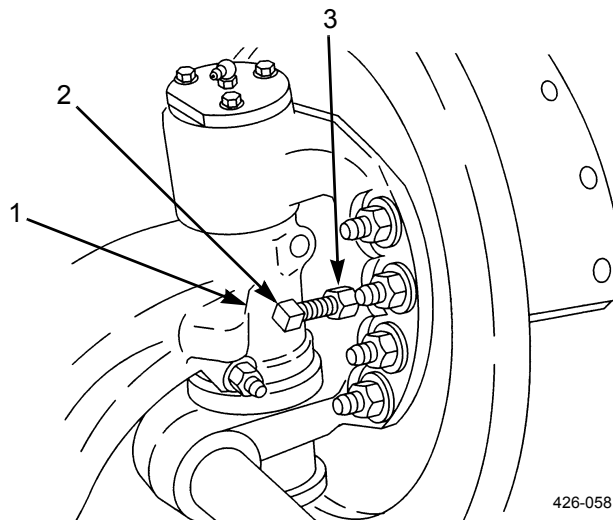

426-058

**STEERING GEAR REPLACEMENT (M915A4R2) - CONTINUED****0265 01****REMOVAL - CONTINUED**

6. Tag and disconnect two hoses (8) from two elbows (7). Plug hoses.

**NOTE**

Note position of elbows for installation.

7. Remove two elbows (7) from steering gear (6).

**WARNING**

Use extreme caution when handling heavy parts. Provide adequate support and use assistance during procedure. Ensure that any lifting device used is in good condition and of suitable capacity. Keep clear of heavy parts supported only by lifting device. Failure to follow this warning may result in injury or death to personnel.

8. With steering gear supported by hydraulic jack, remove three nuts (4), six washers (5), three bolts (9), and steering gear (6) from vehicle.

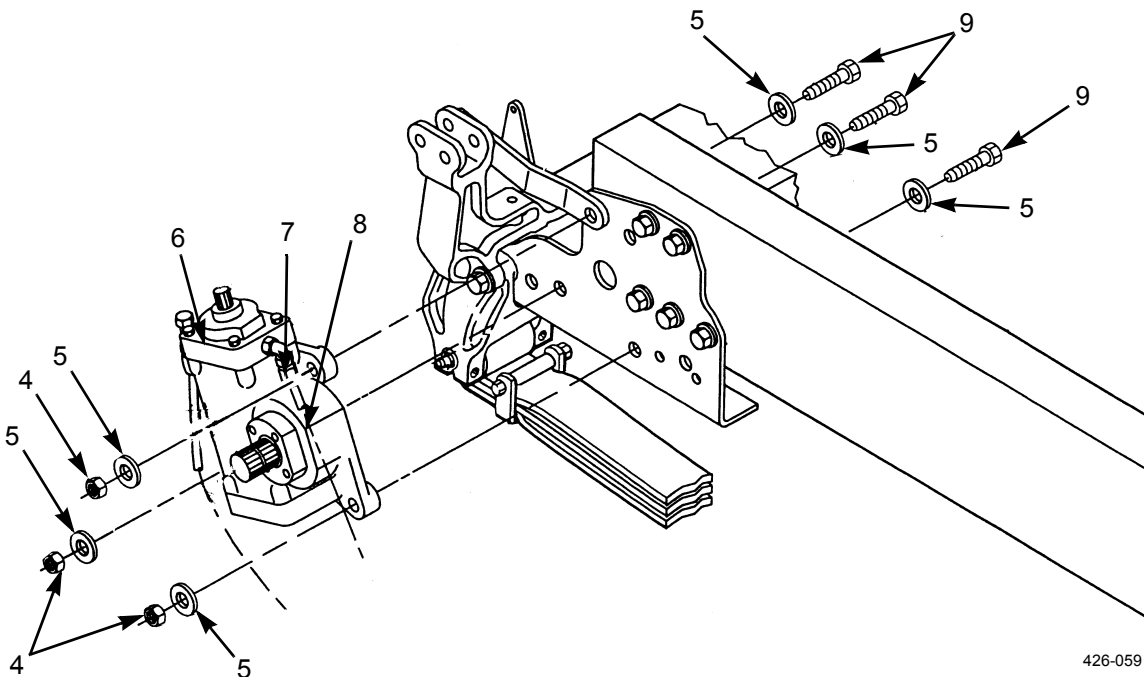

426-059

**INSTALLATION****WARNING**

Use extreme caution when handling heavy parts. Provide adequate support and use assistance during procedure. Ensure that any lifting device used is in good condition and of suitable capacity. Keep clear of heavy parts supported only by lifting device. Failure to follow this warning may result in injury or death to personnel.

1. Using hydraulic jack, position steering gear (6) to vehicle and install steering gear with three bolts (9), six washers (5), and three nuts (4). Tighten nuts to 427 lb-ft (579 Nm).
2. Install two elbows (7) to steering gear (6). Tighten each elbow to 37 lb-ft (51 Nm). Tighten jam nut of one (pressure) elbow to 41 lb-ft (56 Nm).
3. Remove plugs from two hoses (8) and connect hoses to two elbows (7). Tighten each hose until firm resistance is felt, then tighten an additional 1/6 turn.
4. Install pitman arm and drag link (WP 0158 00).
5. Install lower end of universal steering shaft (WP 0157 00).

**NOTE**

Perform the following steps to fill, bleed, and check operation of steering system.

6. Fill steering reservoir (WP 0024 00).

**NOTE**

DO NOT attempt to turn steering wheel until step 10.

7. Crank engine (TM 9-2320-303-10) for 10 seconds without allowing engine to start. Immediately stop engine if it does start. Check reservoir and add oil if necessary.
8. Repeat step 7 three times.
9. Crank engine and allow engine to start and idle for two minutes. Stop engine and again check level of oil in reservoir. Add oil if necessary.
10. Again start engine and turn front wheels fully left and right several times to warm the oil.
11. With engine still running, slowly turn front wheels fully left and right while checking oil in reservoir for frothing or a change in level. This indicates leaks in the steering system. Replace hoses or tighten fittings as necessary.
12. Road test vehicle. Note position of steering wheel spokes. Adjust position of steering wheel (WP 0156 00) as necessary.

**END OF WORK PACKAGE**



---

**STEERING COLUMN REPLACEMENT**

**0266 00**

---

**THIS WORK PACKAGE COVERS**

Removal, Installation

---

**INITIAL SETUP**

**Maintenance Level**

Direct Support

**Tools and Special Tools**

Tool kit, general mechanic's (Item 102, WP 0313 00)

Wrench, torque, 0-300 lb-in (Item 109, WP 0313 00)

Wrench, torque, 15-75 lb-ft (Item 110, WP 0313 00)

**Materials/Parts**

Compound, sealing (Item 14, WP 0312 00)

Detergent (Item 18, WP 0312 00)

Primer, adhesive (Item 38, WP 0312 00)

Nut

Screw

**Equipment Condition**

Steering wheel removed (WP 0156 00)

---

**REMOVAL**

1. Loosen clamp and remove trailer brake control valve (2).
2. Loosen clamp screw and remove turn signal switch (1).
3. Disconnect connector from turn signal switch (1).
4. Disconnect horn wire from steering column (3).

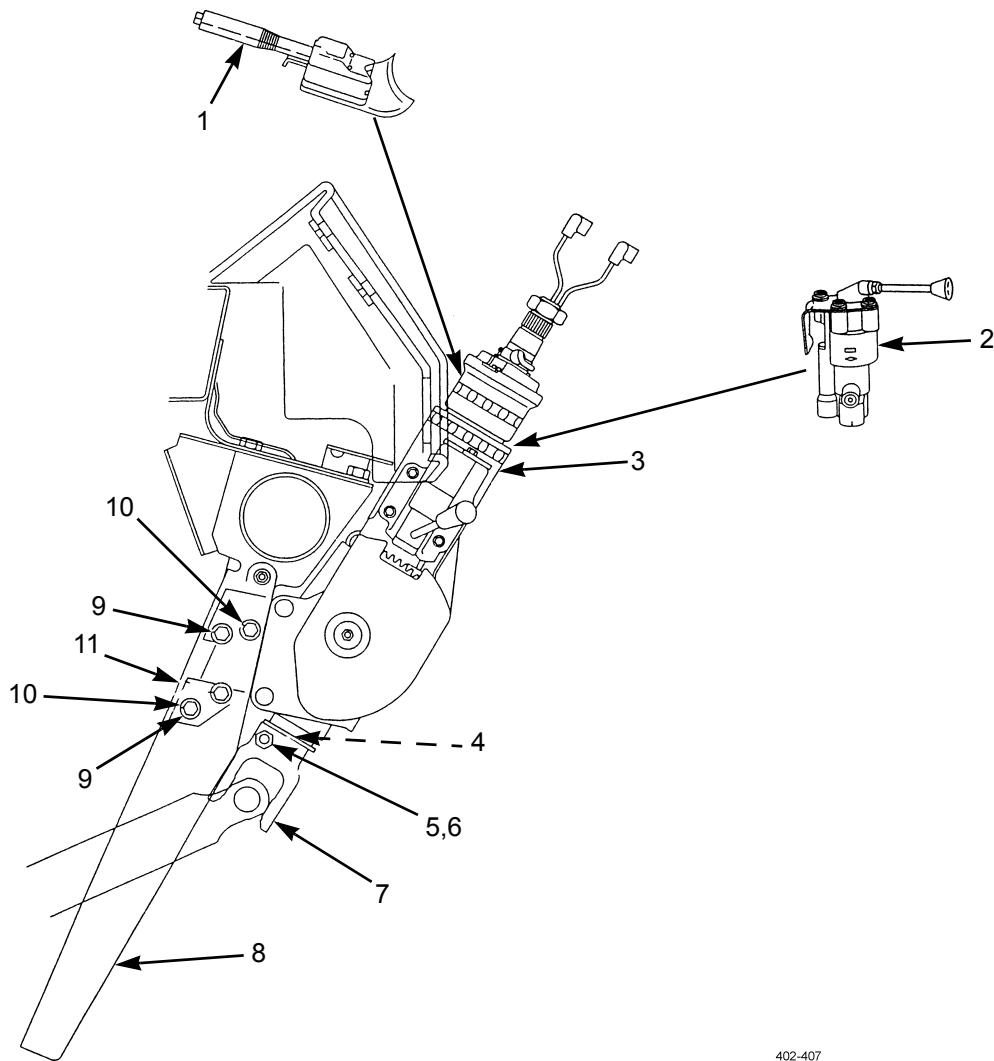

402-407



**REMOVAL - CONTINUED****NOTE**

Heat base of yoke, if necessary, for ease in removal.

5. Remove nut (4) and bolt (5) from steering column yoke (6) and separate yoke from steering column (3). Discard nut and bolt.
6. Remove two screws (9) and spacer block (10) from steering column (3) and steering column bracket (7).
7. Loosen two screws (8) and remove steering column (3) from vehicle.

**INSTALLATION**

1. Position steering column (3) to steering column bracket (7) and tighten two screws (9) to 15 lb-ft (20 Nm).
2. Install spacer block (10) with two screws (9).
3. Using wire brush and liquid detergent, clean serrations of steering column yoke (6) and shaft.
4. Apply adhesive primer to steering column shaft. Let dry for five minutes.
5. Apply sealing compound to inside of steering column yoke (6) and install yoke to shaft.
6. Install bolt (5) and nut (4). Tighten nut to 37 lb-ft (50 Nm).
7. Apply sealing compound to exposed threads of screw.
8. Connect horn wire to steering column (3).
9. Connect connector to turn signal switch (1).
10. Install turn signal switch (1) to steering column (3) and tighten clamp screw.
11. Install trailer brake control valve (2) and tighten clamp.
12. Install steering wheel (WP 0156 00).
13. Test drive to check steering wheel alignment and smooth operation of steering column.

**END OF WORK PACKAGE**



**FIFTH WHEEL REPLACEMENT****0267 00****THIS WORK PACKAGE COVERS**

Removal, Installation

**INITIAL SETUP****Maintenance Level**

Direct Support

**Tools and Special Tools**

Tool kit, general mechanic's (Item 102, WP 0313 00)

Sling, nylon (Item 86, WP 0313 00)

**Materials/Parts**

Nut, lock (P/N M45913/1-10CG5C) (23)

**Materials/Parts - Continued**

Screw, cap (P/N B1821BH063C225N) (22)

Washer, flat (P/N MS15795-821) (44)

**Personnel Required**

Two

**Equipment Condition**

Air system drained (TM 9-2320-303-10)

**WARNING**

- Use extreme caution when handling heavy parts. Provide adequate support and use assistance during procedure. Ensure that any lifting device used is in good condition and of suitable load capacity. Keep clear of heavy parts supported only by lifting device. Failure to follow this warning may result in death or injury to personnel.
- Fifth wheel weighs 550 lb (249.7 kg). Use hoist with lifting capacity of 800 lb (363.2 kg) to remove fifth wheel. Failure to do so could result in injury to personnel.

**REMOVAL**

1. Disconnect air hose (1) from cylinder (7).
2. Remove locknut (8), two washers (9), screw (10), and air hose bracket (11). Discard locknut.

**NOTE**

Fasteners used to install fifth wheel to frame of vehicle are huckbolts. They can not be unscrewed and must be cut off using an anvil and air chisel or a huck collar cutter. Replacement of fifth wheel requires that all huckbolts be removed and grade 8 bolts and locknuts be installed.

3. Remove 22 huckbolts (3) from fifth wheel (2). Discard huckbolts.
4. Using suitable lifting device, remove fifth wheel (2) from frame.

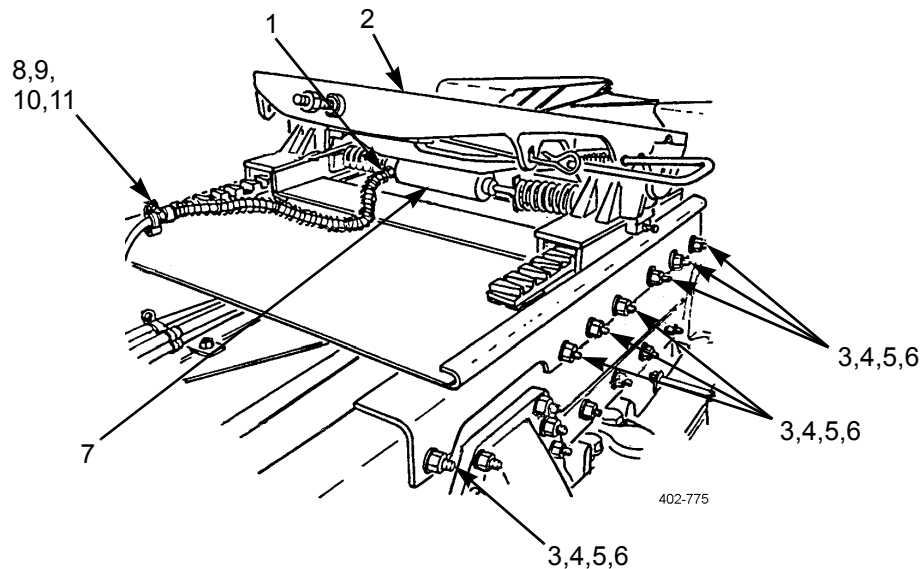
**INSTALLATION**

1. Using suitable lifting device, align and install fifth wheel (2) on frame.
2. Install 22 bolts (4), 44 washers (5) and 22 locknuts (6).
3. Install air hose bracket (11) with screw (10), two washers (9) and new locknut (8).
4. Connect air hose (1) to cylinder (7).

**END OF WORK PACKAGE**

---

**SLIDE BRACKET AND PLATE REPAIR**

---

0268 00

**THIS WORK PACKAGE COVERS**

Disassembly, Assembly

---

**INITIAL SETUP****Maintenance Level**

Direct Support

**Equipment Condition**

Top plate removed (WP 0269 00)

**Tools and Special Tools**

Tool kit, general mechanic's (Item 102, WP 0313 00)

Slider, spring compressor (Item 84, WP 0313 00)

---

**DISASSEMBLY**

1. Install spring compressor tool (1).

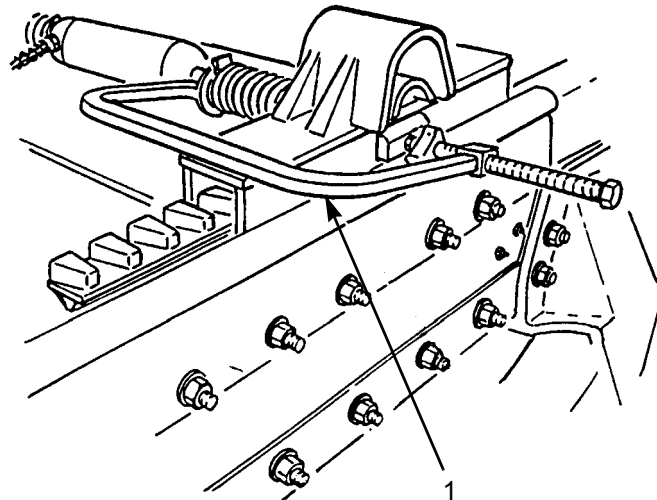

402-776

**DISASSEMBLY - CONTINUED**

2. Compress spring (3). Remove pin (2) and swing air cylinder (4) out of the way.
3. Remove spring compressor tool (1).

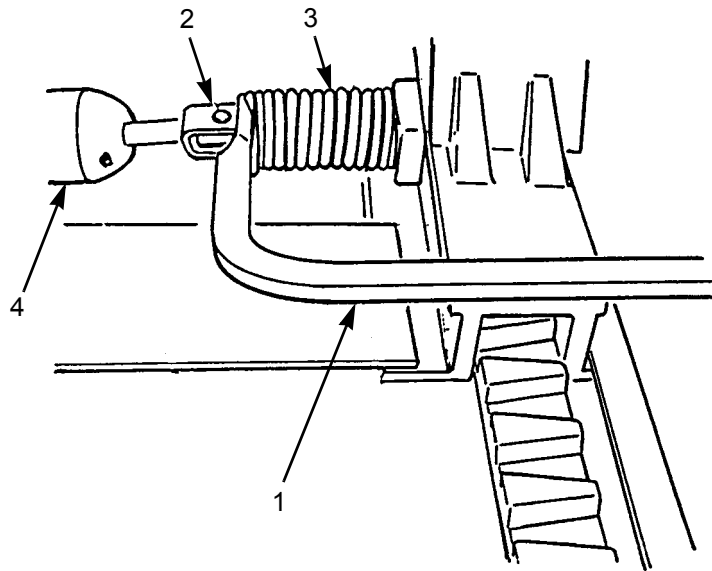

402-777

4. Remove spring retainer (7), spring (3), pin retainer (6), and plunger assembly (5).
5. Repeat steps 1 through 4 for opposite side plunger assembly.
6. Disconnect air hose (8) and remove air cylinder (4).

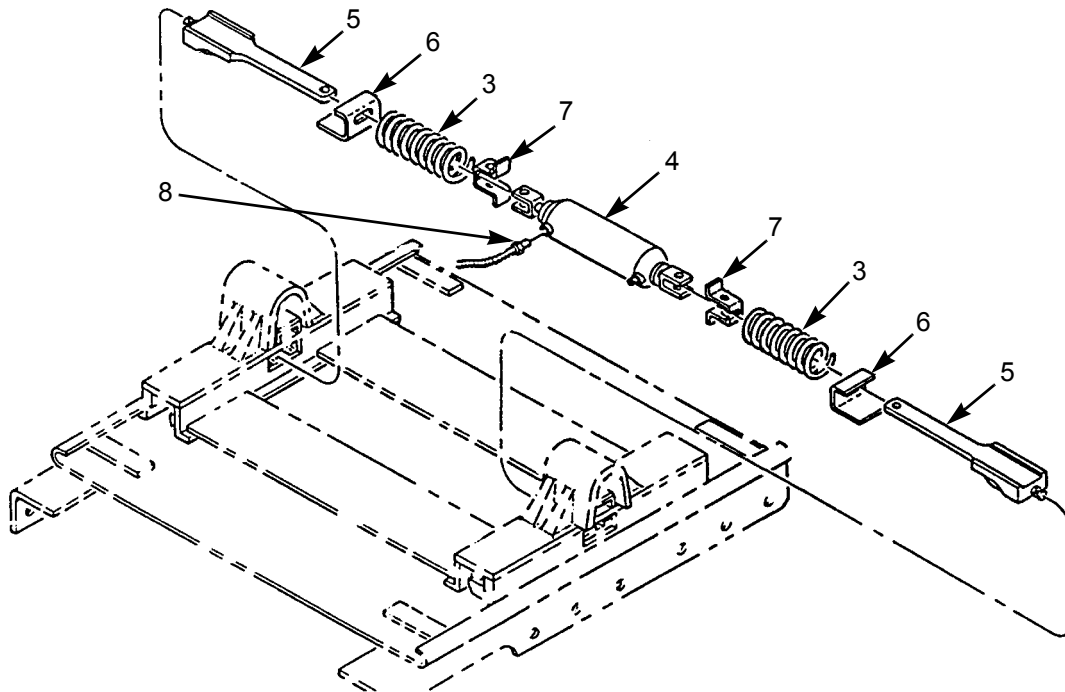

402-778

**ASSEMBLY**

1. Install air cylinder (4) and connect air hose (8).
2. Install plunger assembly (5), pin retainer (6), spring (3), and spring retainer (7).
3. Install spring compressor tool (1).
4. Compress spring (3) and place air cylinder (4) in position.
5. Install pin (2) and release spring compressor tool (1).
6. Repeat steps 2 through 5 for opposite side plunger assembly.
7. Install top plate (WP 0269 00).
8. Adjust fifth wheel (WP 0170 00).

**END OF WORK PACKAGE**





---

**FIFTH WHEEL TOP PLATE REPLACEMENT**

**0269 00**

---

**THIS WORK PACKAGE COVERS**

Removal, Installation

---

**INITIAL SETUP**

**Maintenance Level**

Direct Support

**Tools and Special Tools**

Tool kit, general mechanic's (Item 102, WP 0313 00)

Sling, nylon (Item 86, WP 0313 00)

**Materials/Parts**

Compound, antiseize (Item 11, WP 0312 00)

Kit (P/N RK-04413)

**Personnel Required**

Two

---



**WARNING**



- Use extreme caution when handling heavy parts. Provide adequate support and use assistance during procedure. Ensure that any lifting device used is in good condition and of suitable load capacity. Keep clear of heavy parts supported only by lifting device. Failure to follow this warning may result in death or injury to personnel.
- Top plate weighs 320 lb (145 kg). Use hoist with lifting capacity of 500 lb (227 kg) to remove or install top plate. Failure to do so could result in injury to personnel.

**FIFTH WHEEL TOP PLATE REPLACEMENT - CONTINUED****0269 00****REMOVAL**

1. Using suitable lifting device, support top plate (2) and remove two roll pins (1). Discard roll pins.
2. Remove two pivot pins (3) and top plate (2). Discard pivot pins.
3. Remove and discard two cushion supports (5) from slide bracket (4).

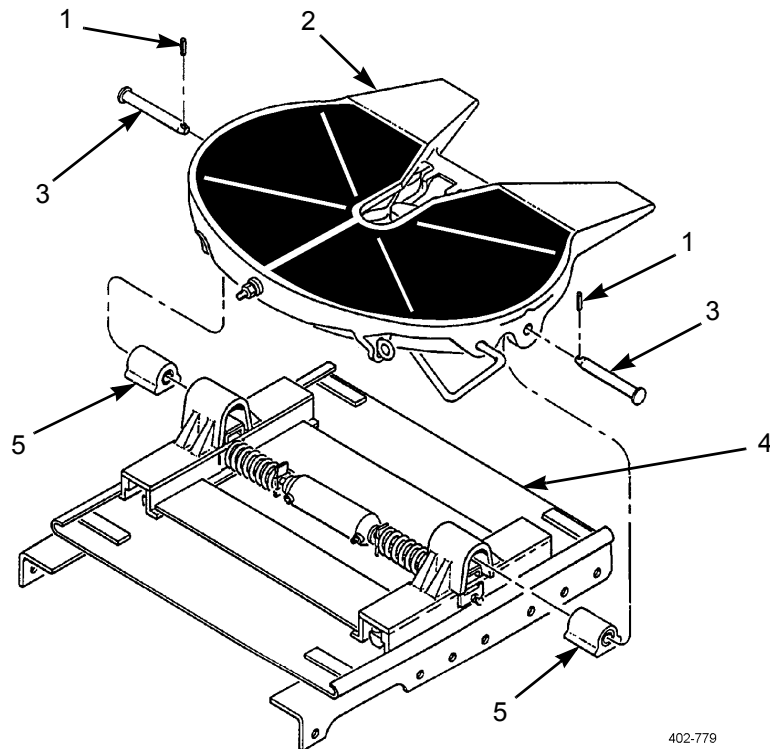
**INSTALLATION**

1. Install two new cushion supports (5) in slide bracket (4).
2. Coat two new pivot pins (3) with antiseize compound.
3. Using suitable lifting device, align top plate (2) with slide bracket (4) and install two new pivot pins (3) and two new roll pins (1).

**END OF WORK PACKAGE**

---

**FIFTH WHEEL TOP PLATE REPAIR**

---

0270 00

**THIS WORK PACKAGE COVERS**Disassembly, Assembly

---

**INITIAL SETUP****Maintenance Level**

Direct Support

**Tools and Special Tools**

Tool kit, general mechanic's (Item 102, WP 0313 00)

Tester, kingpin lock (Item 100, WP 0313 00)

Wrench, torque, 0-300 lb-in (Item 109, WP 0313 00)

**Materials/Parts**

Compound, antiseize (Item 11, WP 0312 00)

Tape, double-sided (Item 43, WP 0312 00)

**Materials/Parts - Continued**

Kit (P/N RK-331-1)

Kit (P/N RK-331-2)

**Personnel Required**

Two

**References**

TM 9-2320-303-10

WP 0170 00

**Equipment Condition**Top plate removed (WP 0269 00)

---

***DISASSEMBLY***

1. Ensure locks (25) are in closed position.
2. Remove and discard nut (8), washer (7), rubber washer (6), and lock-adjust tag (5).
3. Remove and discard screw (11), washer (2), roller (12), and washer (2).
4. Remove and discard locknut (26), screw (9), washer (10), roller (28), cam plate (27), and washer (10).

DISASSEMBLY - CONTINUED

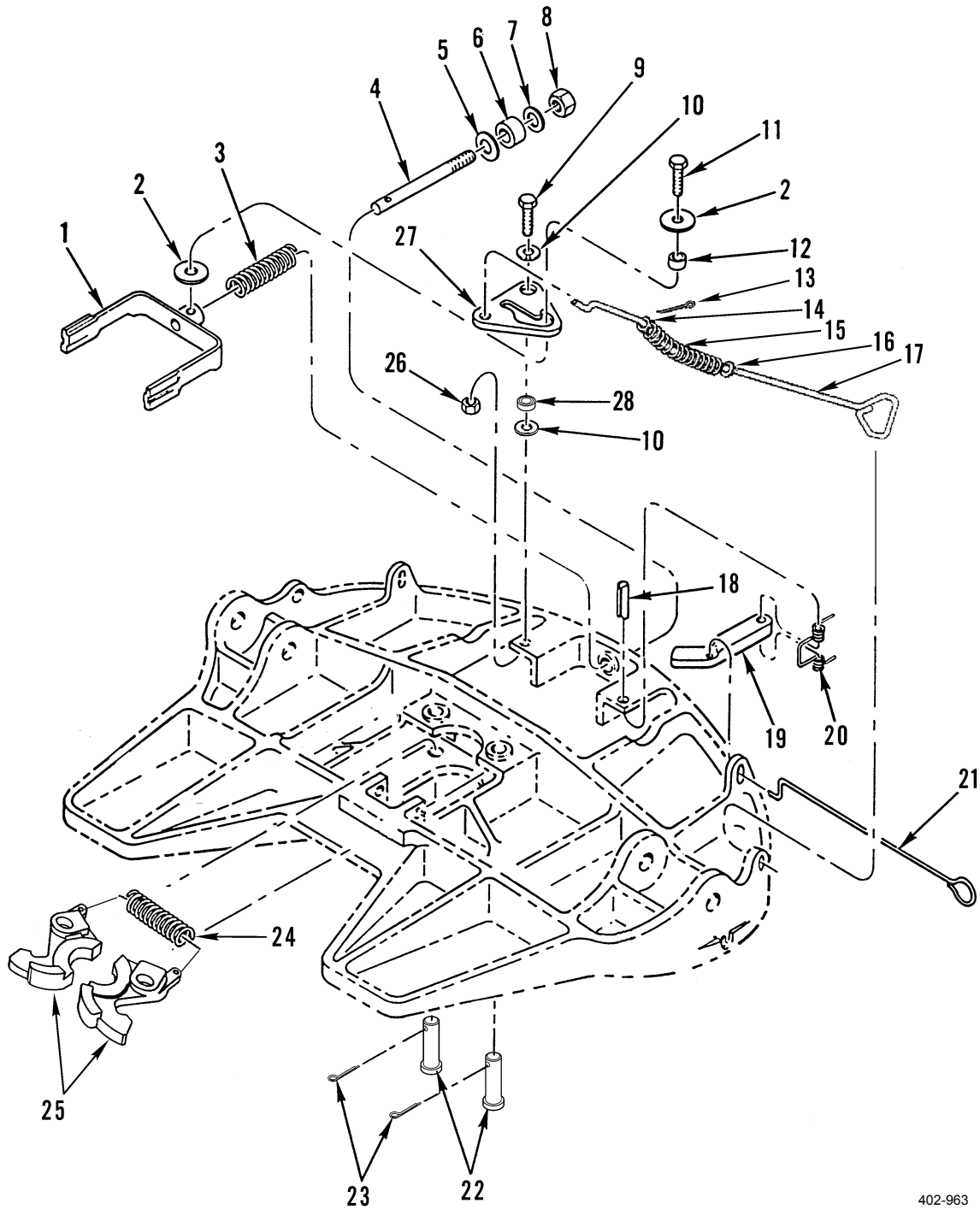

402-963

5. Remove primary lock handle (17) from top plate.
6. Remove and discard washer (16), spring (15), washer (14), and cotter pin (13) from primary lock handle (17).
7. Remove roll pin (18), spring (20), lock bar (19), and handle (21). Discard roll pin, spring, and lock bar.

**DISASSEMBLY - CONTINUED**



**WARNING**

When removing spring, compress spring slightly and relieve pressure slowly. Failure to do so could cause spring to fly off, resulting in injury to personnel.

8. Remove and discard shaft (4), spring (3), and yoke (1) from top plate.
9. Remove two cotter pins (23), pins (22) spring (24), and locks (25). Discard cotter pins and pins.

**NOTE**

Lube plates must be replaced as a pair.

10. Remove 18 locknuts (31), washers (30), and two lube plates (29) from top plate. Discard locknuts.

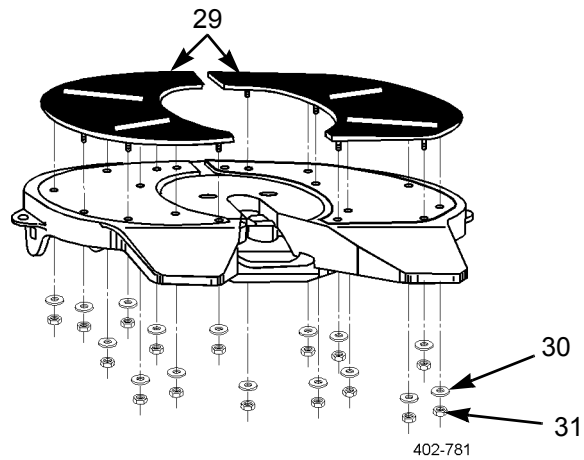

11. Remove two pocket inserts (32) from top plate.

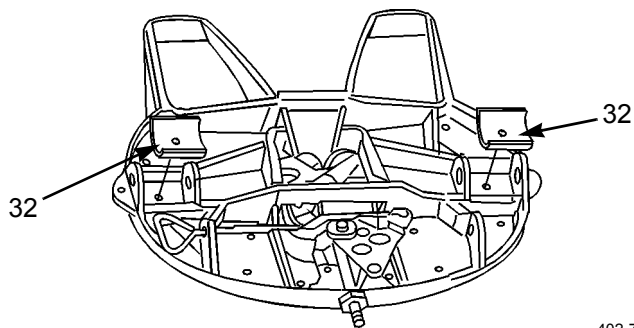

**ASSEMBLY**

1. Apply double-sided tape to two pocket inserts (32) and install on top plate.
2. Ensure top plate mating surface is clean and dry.
3. Install two lube plates (29) to top plate with 18 washers (30) and new locknuts (31).
4. Tighten locknuts (31) to 156 lb-in (18 Nm).

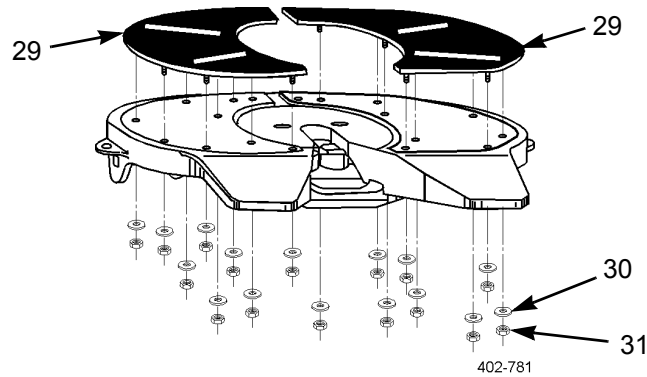

5. Coat pin holes of two locks (25) with antiseize compound and install two locks and spring (24) with larger opening facing toward top of top plate.
6. Install two new pins (22) and new cotter pins (23).
7. Install kingpin lock tester plug between two locks (25) and close locks.

**NOTE**

- Tips of yoke must be flush (1/32 in) with ends of two locks. If yoke falls short, grind outside edges of yoke tips evenly until yoke fits exactly. If yoke extends beyond two locks, build up outside edges of yoke tips using low-hydrogen E70XX welding rod. After welding, grind beads smooth and even until yoke fits exactly.
- Ensure threaded hole is up when installing shaft.

8. Install new spring (3) and new shaft (4) on yoke (1).
9. Install handle (21), new lock bar (19), new spring (20), and new roll pin (18).
10. Install new washer (16), spring (15), washer (14), and cotter pin (13) on primary lock handle (17).
11. Install primary lock handle (17) in top plate.
12. Install new cam plate (27) on primary lock handle (17).

**NOTE**

Install washers with rounded sides facing away from cam plate.

13. Install new washer (10), new roller (28), new washer (10), new screw (9), and new locknut (26) in top plate.
14. Install new washer (2), new roller (12), new washer (2), and new screw (11) in cam plate (27).
15. Install new lock-adjust tag (5), new rubber washer (6), new washer (7), and new nut (8) on shaft (4).

**ASSEMBLY - CONTINUED**

**WARNING**

Locks must be closed while adjusting to ensure contact is made with locks, yoke, and top plate. Failure to do so will result in loss of trailer and possible injury to personnel.

16. Tighten nut (8) until plug fits snugly, but can just be rotated by hand.
17. Open two locks (25) and remove kingpin lock tester plug.



ASSEMBLY - CONTINUED

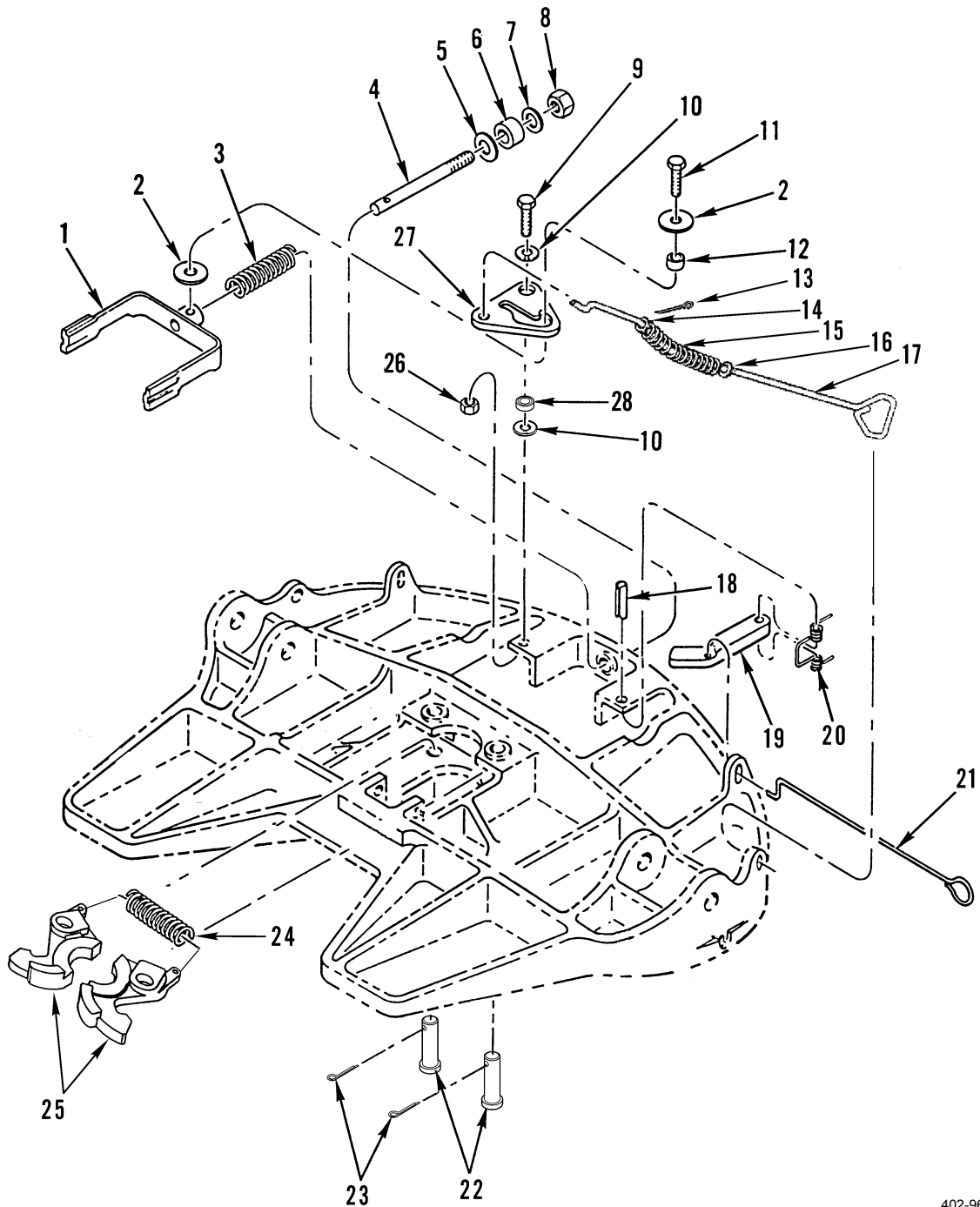

402-963

- 18. Install top plate (WP 0269 00).
- 19. Lubricate fifth wheel (TM 9-2320-303-10).
- 20. Adjust fifth wheel (WP 0170 00).

**END OF WORK PACKAGE**



---

**RAMP REPLACEMENT**

0271 00

---

**THIS WORK PACKAGE COVERS**

Removal, Installation

---

**INITIAL SETUP****Maintenance Level**

Direct Support

**Tools and Special Tools**Tool kit, general mechanic's (Item 102, WP 0313  
00)**Materials/Parts**

Nut, lock (P/N M45913/1-8CG5C) (6)

Nut, lock (P/N M45913/1-10CG5C) (6)

**WARNING**

Use extreme caution when handling heavy parts. Provide adequate support and use assistance during procedure. Ensure that any lifting device used is in good condition and of suitable load capacity. Keep clear of heavy parts supported only by lifting device. Failure to follow this warning may result in death or injury to personnel.

**REMOVAL****NOTE**

- Perform steps 1 through 4 to remove each of two ramps.
- Vehicle may utilize huckbolts instead of screws and locknuts. Replace all loose or damaged huckbolts with grade 8 screws and locknuts.

**REMOVAL - CONTINUED**

1. Remove three locknuts (10), six washers (1) and three screws (2). Discard locknuts.
2. Remove locknut (4), two washers (5) and screw (6). Discard locknut.
3. Remove two locknuts (9), four washers (8) and two screws (7). Discard locknuts.
4. Remove ramp (3) from vehicle.

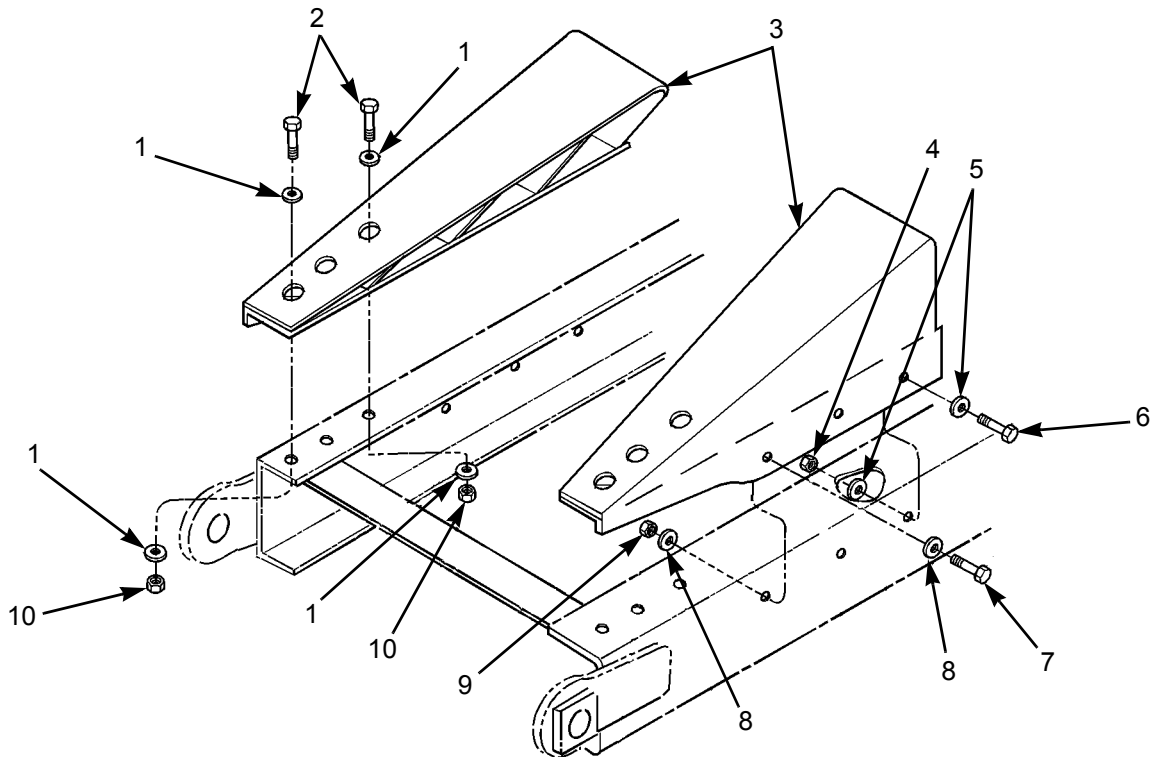

402-783

**INSTALLATION****NOTE**

Perform steps 1 through 4 to install each of two ramps.

1. Position ramp (3) to vehicle.
2. Install ramp (3) with two screws (7), four washers (8) and two new locknuts (9).
3. Install screw (6), two washers (5), and new locknut (4).
4. Install three screws (2), six washers (1), and three new locknuts (10).

**END OF WORK PACKAGE**

**OVERSLUNG CROSSMEMBER REPLACEMENT**

**0272 00**

**THIS WORK PACKAGE COVERS**

Removal, Installation

**INITIAL SETUP**

**Maintenance Level**

General Support

**Tools and Special Tools**

Tool kit, general mechanic's (Item 102, WP 0313 00)

Wrench, torque, 50-250 lb-ft (Item 111, WP 0313 00)

**Tools and Special Tools - Continued**

Wrench, torque, 100-600 lb-ft (Item 112, WP 0313 00)

Wrench set, socket, 3/4 in drive (Item 113, WP 0313 00)

**Equipment Condition**

Fender extensions removed (WP 0184 00)

**REMOVAL**

**NOTE**

Step 1 is for left side only.

1. Remove nut (6), washer (5), clamp (7), nut (4), washer (8), and bracket (9).

**NOTE**

Step 2 is for right side only.

2. Remove nut (2), washer (3), and two clamps (1).

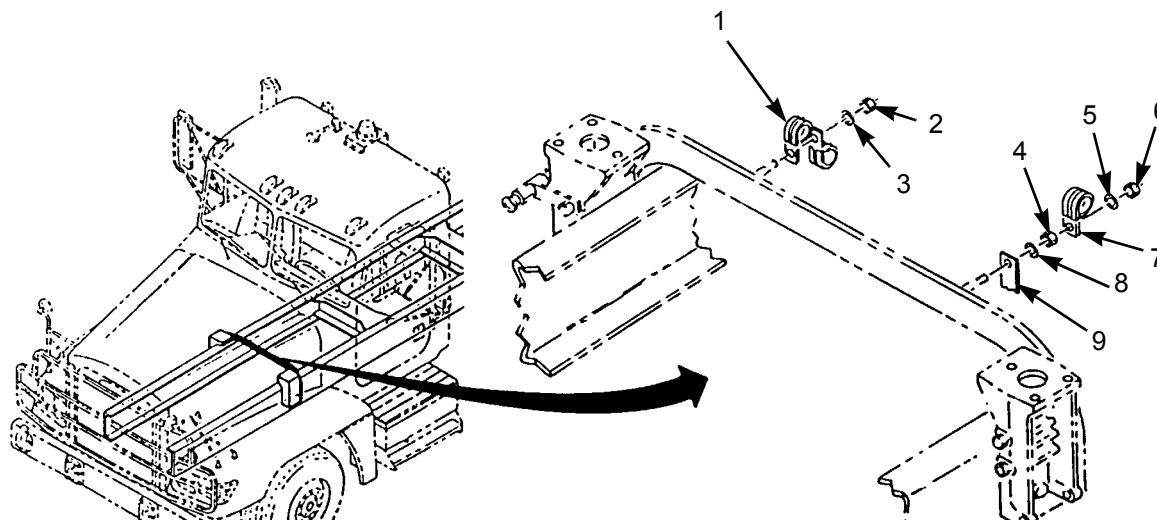

**OVERSLUNG CROSSMEMBER REPLACEMENT - CONTINUED**

0272 00

**REMOVAL - CONTINUED**

3. Remove nut (17), washer (16), capscrew (13), and washer (14).
4. Remove nut (19) and washer (18) and set AOAP valve (10) aside.
5. Remove capscrew (12), washer (11), and overslung crossmember (15).

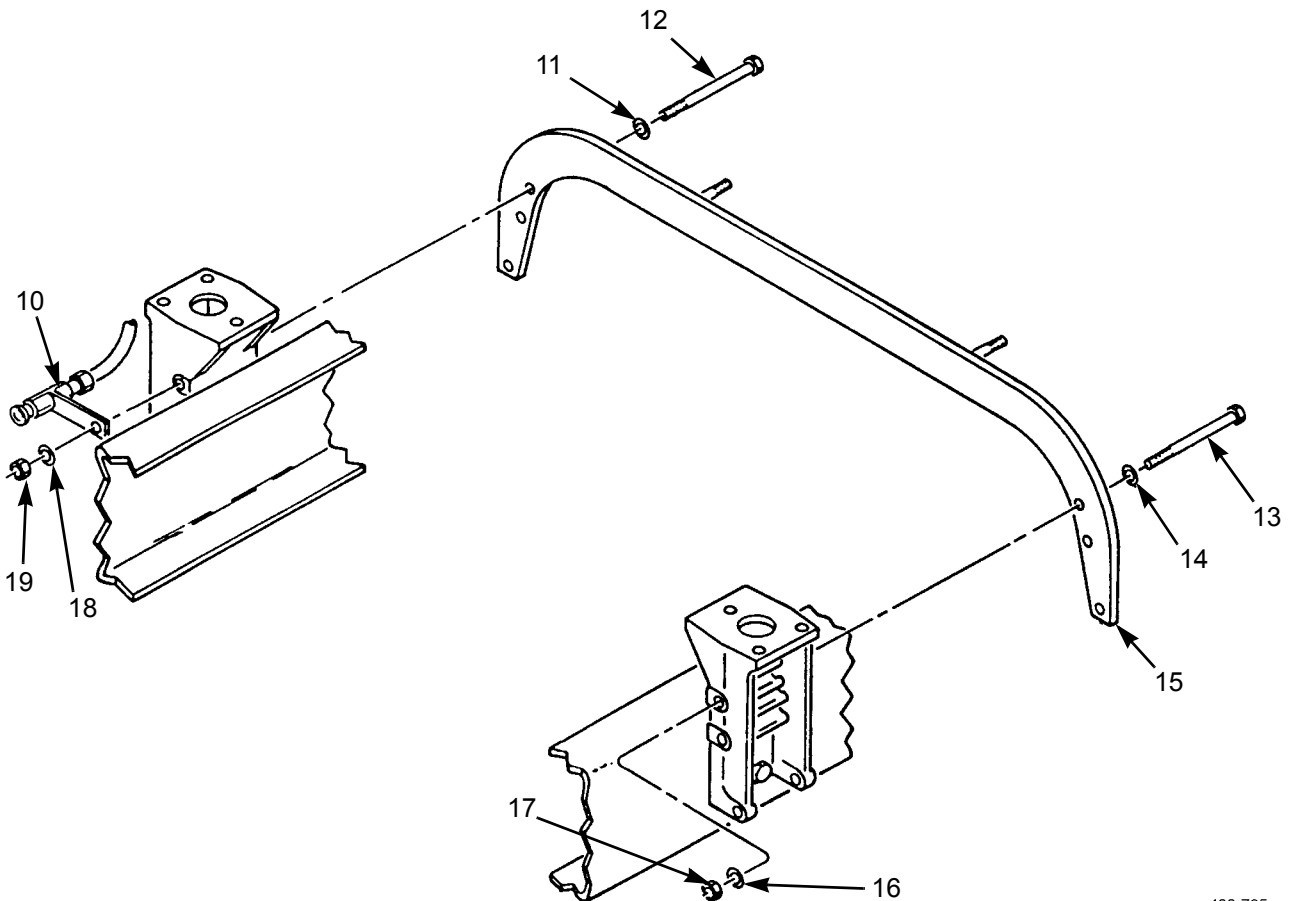

402-785

**INSTALLATION**

1. Install overslung crossmember (15), washer (11), and capscrew (12).
2. Install AOAP valve (10), washer (18), and nut (19).
3. Install washer (14), capscrew (13), washer (16), and nut (17).

**NOTE**

Step 4 is for right side only.

4. Install two clamps (1), washer (3) and nut (2).

**NOTE**

Step 5 is for left side only.

5. Install bracket (9), washer (8), nut (4), clamp (7), washer (5), and nut (6).

INSTALLATION - CONTINUED

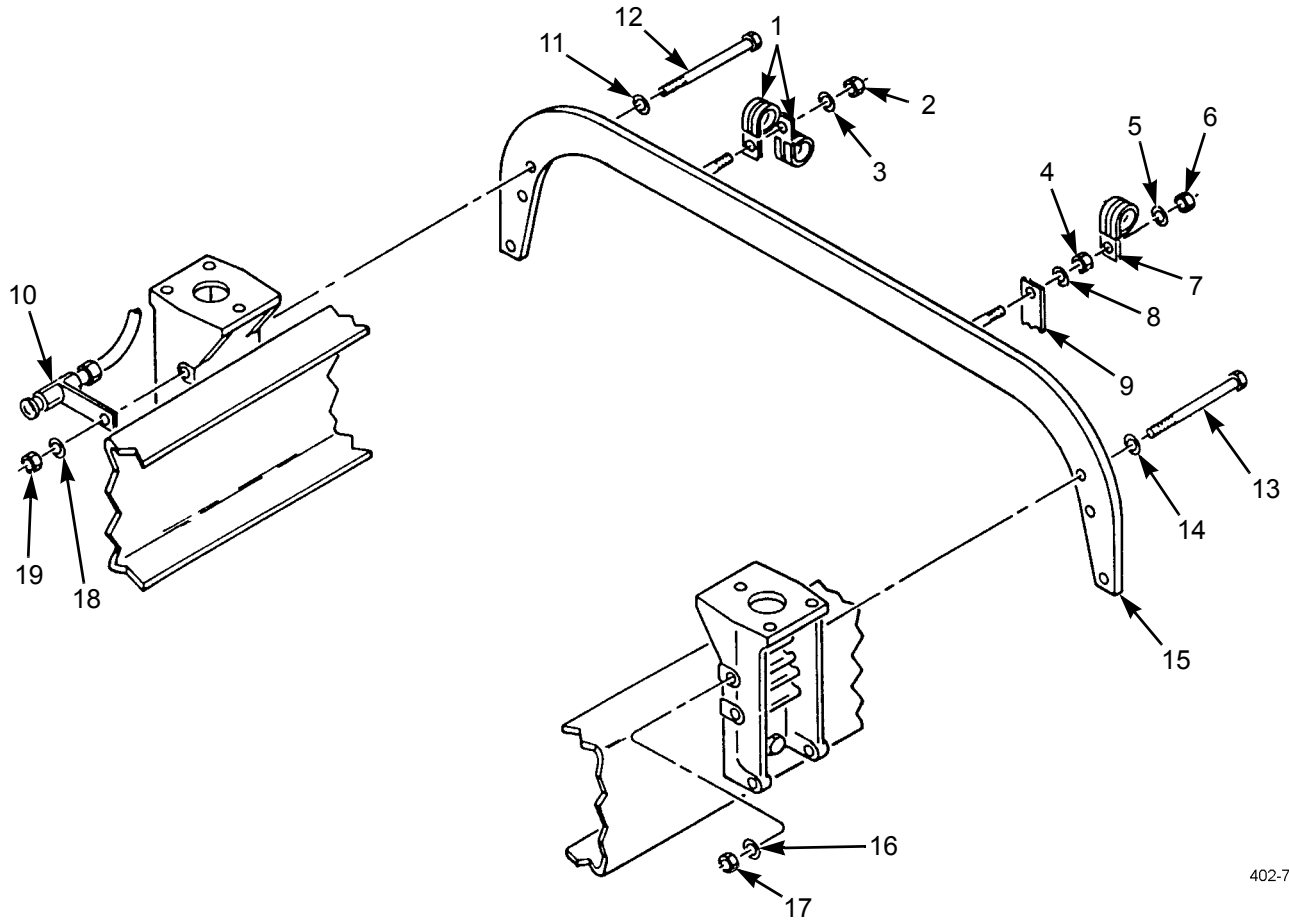

402-786

6. Install fender extensions (WP 0184 00).

**END OF WORK PACKAGE**





---

**CAB ALLIGATOR CROSSMEMBER REPLACEMENT**

---

**0273 00****THIS WORK PACKAGE COVERS**Removal, Installation

---

**INITIAL SETUP****Maintenance Level**

General Support

**Tools and Special Tools**

Tool kit, general mechanic's (Item 102, WP 0313 00)

**Materials/Parts**

Nut, lock (P/N M45913/1-8CG5C) (8)

Nut, lock (P/N M45913/1-10CG5C) (16)

**Personnel Required**

Three

**Equipment Condition**

Spare wheel hoist removed (WP 0171 00)

Left side platform removed (WP 0165 00)

Personal gear storage box and mounting bracket removed (WP 0193 00)

Air dryer removed (WP 0134 00)

Rear platform removed (WP 0172 00)

Forward driveline removed (WP 0116 00)

Fifth wheel removed (WP 0267 00)

Overslung crossmember removed (WP 0272 00)

Rear cab mounts removed (WP 0281 00)

Rear crossmember removed (WP 0276 00)

---

**REMOVAL**

**NOTE**

Following procedure is done on right side of vehicle.

1. Remove screw (4), two washers (3) and bracket (10).
2. Remove 16 locknuts (1), 32 washers (2), 16 screws (6), and bracket (9) with frame sections (7) attached. Discard locknuts.
3. Remove eight locknuts (8), 16 washers (3), eight screws (4), and frame sections (7) from bracket (9). Discard locknuts.

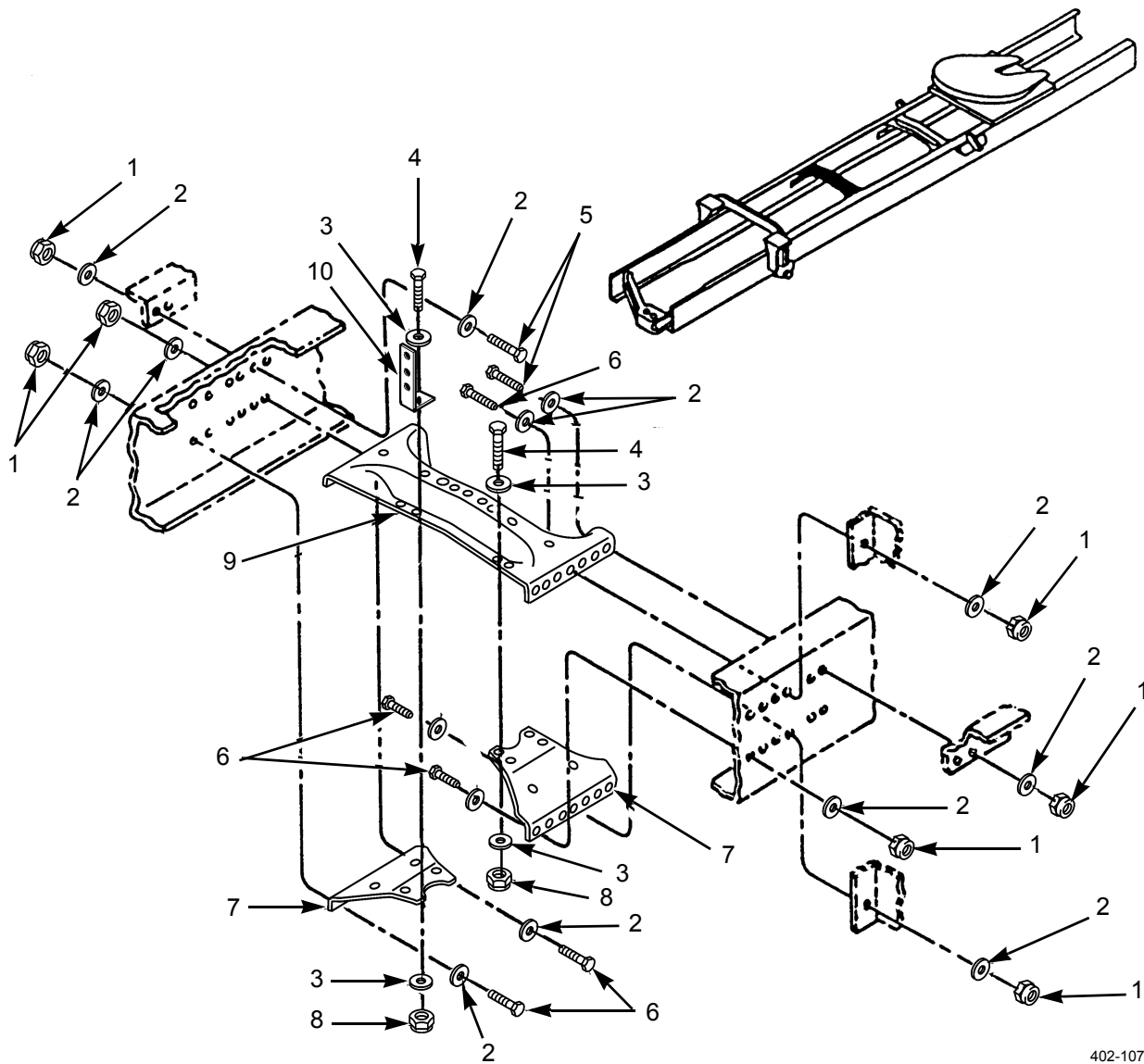

**INSTALLATION**

1. Position frame sections (7) to bracket (9) and install eight screws (4), 16 washers (3), and eight new locknuts.
2. Position bracket (9) with frame sections (7) attached to frame and install 16 screws (6), 32 washers (2), and 16 new locknuts (1).
3. Install bracket (10), screw (4), and two washers (3).
4. Install spare wheel hoist (WP 0171 00).
5. Install left side platform (WP 0165 00).
6. Install personal gear storage box and mounting bracket (WP 0193 00).
7. Install air dryer (WP 0134 00).
8. Install rear platform (WP 0172 00).
9. Install forward driveline (WP 0116 00).
10. Install fifth wheel (WP 0267 00).
11. Install overslung crossmember (WP 0272 00).
12. Install rear cab mounts (WP 0281 00).
13. Install rear crossmember (WP 0276 00).

**END OF WORK PACKAGE**



---

**MIDSHIPS ALLIGATOR CROSSMEMBER REPLACEMENT**

---

**0274 00**

**THIS WORK PACKAGE COVERS**

Removal, Installation

---

**INITIAL SETUP**

**Maintenance Level**

General Support

**Tools and Special Tools**

Tool kit, general mechanic's (Item 102, WP 0313 00)

**Materials/Parts**

Nut, lock (P/N M45913/1-10CG5C) (16)

**Equipment Condition**

Left side platform removed (WP 0165 00)

**Equipment Condition - Continued**

Personal gear storage box and mounting bracket removed (WP 0193 00)

Air dryer removed (WP 0134 00)

Rear platform removed (WP 0172 00)

Right rear fender removed (WP 0189 00)

Fifth wheel removed (WP 0267 00)

Rear crossmember removed (WP 0276 00)

---

**REMOVAL - CONTINUED**

1. Remove eight locknuts (1), 16 washers (3), eight screws (6), and bracket (4) with frame sections (5) attached. Discard locknuts.
2. Remove eight locknuts (1), 16 washers (3), eight screws (6), and bracket (4) with frame sections (5) attached. Discard locknuts.

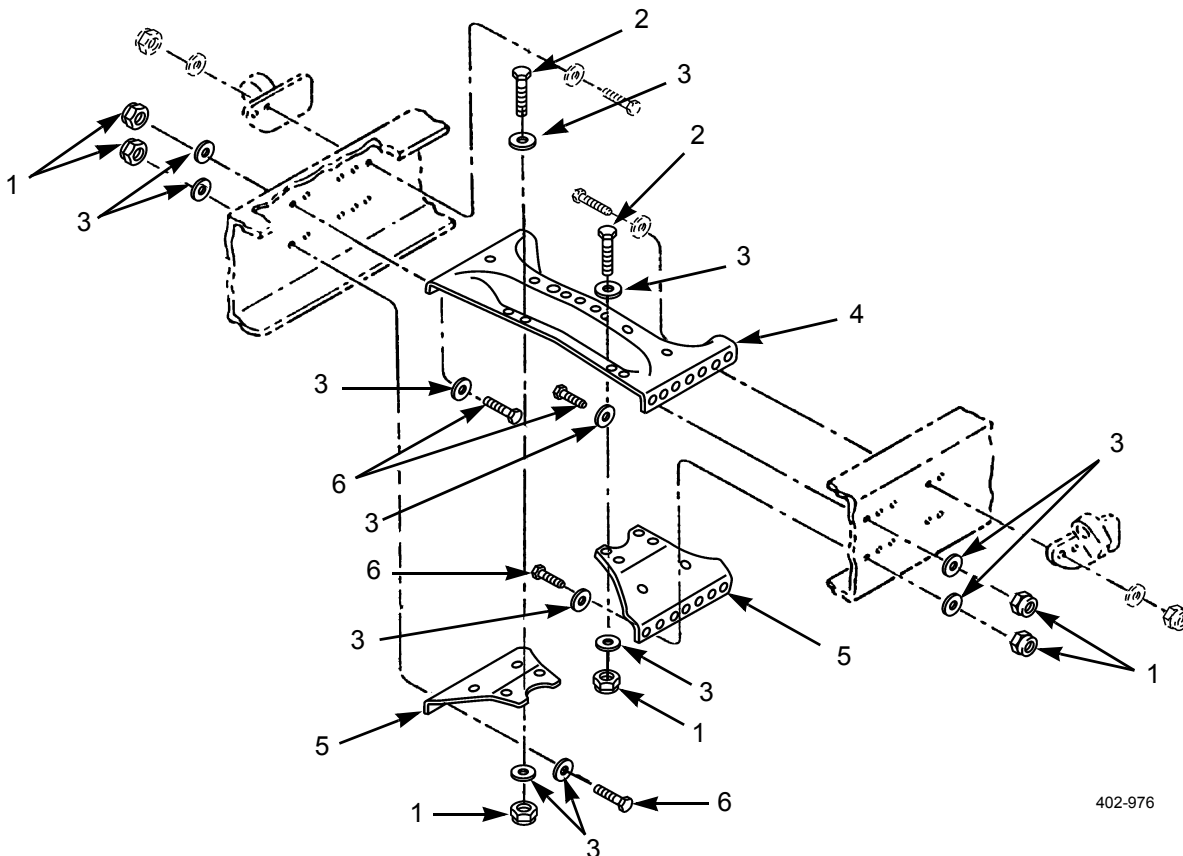

402-976

**INSTALLATION**

1. Position frame sections (5) on bracket (4) and install eight screws (2), 16 washers (3), and eight new locknuts (1).
2. Position bracket (4) with frame sections (5) attached to frame and install eight screws (6), 16 washers (3), and eight new locknuts (1).
3. Install left side platform (WP 0165 00).
4. Install personal gear storage box and mounting bracket (WP 0193 00).
5. Install air dryer (WP 0134 00).
6. Install rear platform (WP 0172 00).
7. Install right rear fender (WP 0189 00).
8. Install fifth wheel (WP 0267 00).
9. Install rear crossmember (WP 0276 00).

**END OF WORK PACKAGE**

**REAR SUSPENSION CROSSMEMBER REPLACEMENT**

**0275 00**

**THIS WORK PACKAGE COVERS**

Removal, Installation

**INITIAL SETUP**

**Maintenance Level**

General Support

**Tools and Special Tools**

Tool kit, general mechanic's (Item 102, WP 0313 00)

**Personnel Required**

Two

**Equipment Condition**

Rear anti-lock brake system (ABS) air solenoids removed (WP 0152 00)

**Equipment Condition - Continued**

Rear tractor protection valve removed (WP 0143 00)

Rear relay valve removed (WP 0145 00)

Rear quick-release valve removed (WP 0148 00)

Fifth wheel removed (WP 0267 00)

Rear spring hangers removed (WP 0285 00)

Torque rods removed (WP 0286 00)

**REMOVAL**

1. Remove two nuts (3), two washers (4), and two clamps (1) and set hose (2) aside.

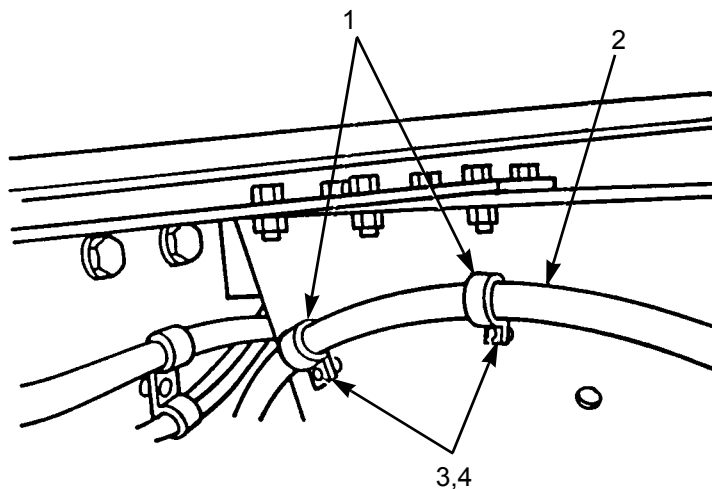

402-797

**REMOVAL - CONTINUED**

2. Remove two nuts (6), two washers (7), and two clamps (9) and set two hoses (5 and 8) aside.

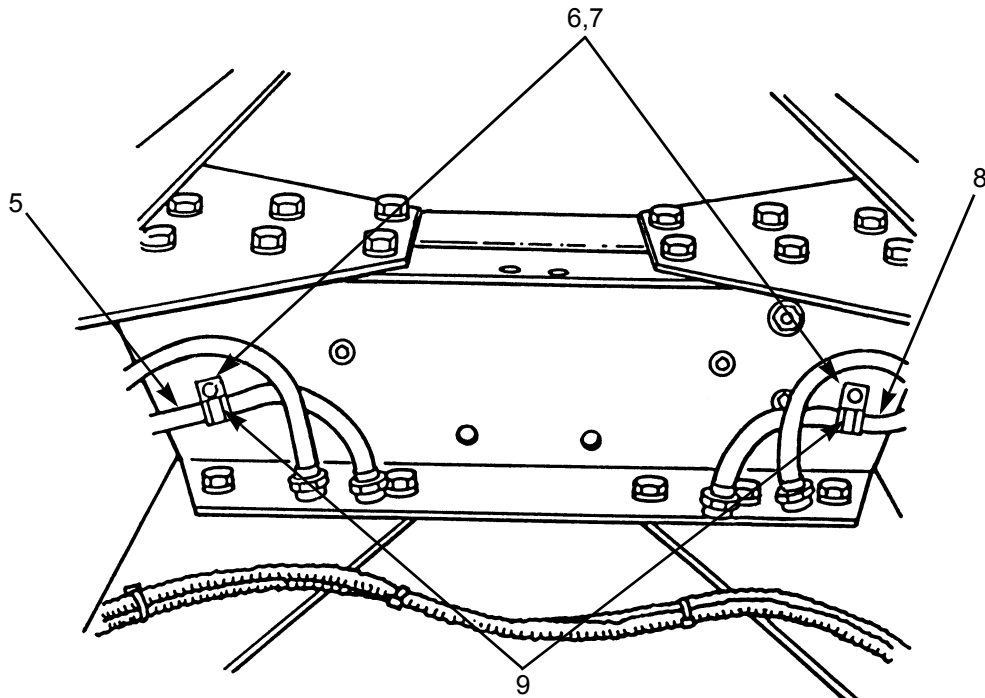

402-798

3. Remove four nuts (35), four washers (34), four capscrews (32), and four washers (33) from two rear suspension crossmembers (15 and 17).
4. Remove 12 nuts (24), 12 washers (23), 12 capscrews (13), 12 washers (14), and rear suspension crossmember (17).
5. Remove 12 nuts (29), 12 washers (28), 12 capscrews (11), 12 washers (10), rear suspension crossmember (15), and two gussets (12 and 16).

**NOTE**

Mark left and right gussets prior to removal to aid in installation.

6. Remove four nuts (30), four washers (31), four capscrews (25), four washers (26), and left gusset (27).
7. Remove four nuts (18), four washers (19), four capscrews (22), four washers (21), and right gusset (20).

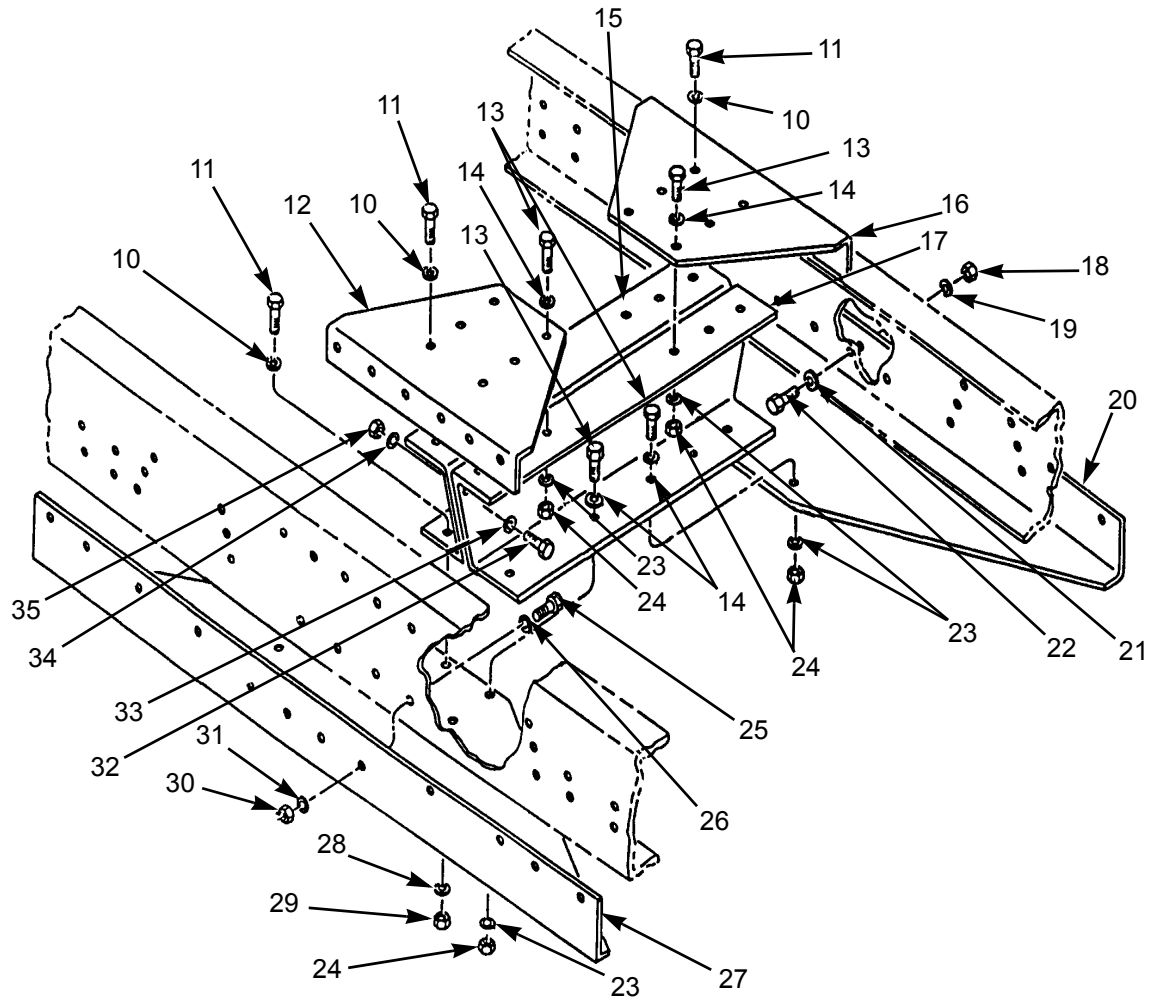

**REMOVAL - CONTINUED**

402-799

**INSTALLATION**

1. Install right gusset (20), four washers (21), four capscrews (22), four washers (19), and four nuts (18).
2. Install left gusset (27), four washers (26), four capscrews (25), four washers (31), and four nuts (30).
3. Install two gussets (12 and 16), rear suspension crossmember (15), 12 washers (10), 12 capscrews (11), 12 washers (28), and 12 nuts (29).
4. Install rear suspension crossmember (17), 12 washers (14), 12 capscrews (13), 12 washers (23), and 12 nuts (24).
5. Install four washers (33), four capscrews (32), four washers (34), and four nuts (35) on two rear suspension crossmembers (15 and 17).
6. Position two hoses (5 and 8) and install two clamps (9), two washers (6), and two nuts (7).

**INSTALLATION - CONTINUED**

7. Position hose (2) and install two clamps (1), two washers (3), and two nuts (4).

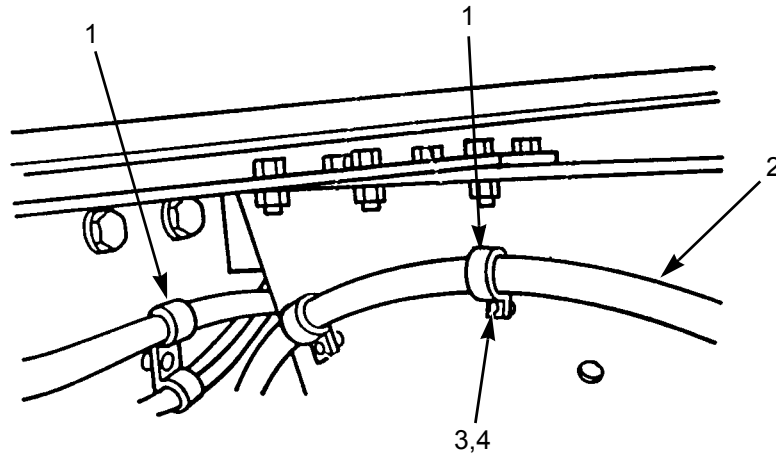

402-797

8. Install rear tractor protection valve (WP 0143 00).  
9. Install rear relay valve (WP 0145 00).  
10. Install rear quick-release valve (WP 0148 00).  
11. Install fifth wheel (WP 0267 00).  
12. Install rear spring hangers (WP 0285 00).  
13. Install torque rods (WP 0286 00).  
14. Install rear anti-lock brake system (ABS) air solenoids (WP 0152 00).

**END OF WORK PACKAGE**

**REAR CROSSMEMBER REPLACEMENT**

**0276 00**

**THIS WORK PACKAGE COVERS**

Removal, Installation

**INITIAL SETUP**

**Maintenance Level**

General Support

**Tools and Special Tools**

- Tool kit, general mechanic's (Item 102, WP 0313 00)
- Wrench, torque, 50-250 lb-ft (Item 111, WP 0313 00)
- Wrench, torque, 100-600 lb-ft (Item 112, WP 0313 00)
- Wrench set, socket, 3/4 in drive (Item 113, WP 0313 00)

**Materials/Parts**

- Strap, tiedown (Item 41, WP 0312 00) (4)
- Nut, lock (P/N 23-09901-116) (12)
- Nut, lock (P/N M45913/1-8CG5C)
- Nut, lock (P/N M45913/1-10CG5C) (12)

**Equipment Condition**

- Taillight brackets removed (WP 0081 00)
- Pintle hook removed (WP 0168 00)



**WARNING**



Use extreme caution when handling heavy parts. Provide adequate support and use assistance during procedure. Ensure that any lifting device used is in good condition and of suitable load capacity. Keep clear of heavy parts supported only by lifting device. Failure to follow this warning may result in death or injury to personnel.

**NOTE**

This task covers replacement of the REAR crossmember and is typical of procedures used to replace other crossmembers of the vehicle.

**REMOVAL**

1. Remove locknut (1), clamp (2), four tiedown straps (4) and set wiring harness (3) aside. Discard locknut and tiedown straps.

**NOTE**

Vehicle may utilize huckbolts instead of screws and locknuts. Replace all loose or damaged huckbolts with grade eight screws and locknuts.

2. Remove eight locknuts (6), and washers (7), towing bracket (9), four screws (8), and reinforcement assembly (5). Discard locknuts.

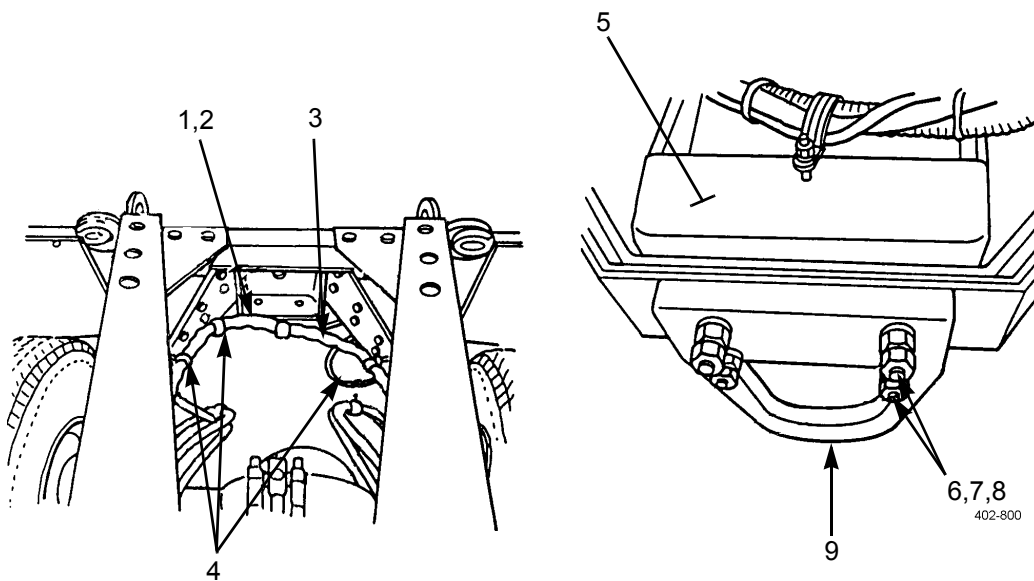

3. Remove five locknuts (10), ten washers (11), five screws (12), two spacers (19), and right side gusset (13). Discard locknuts.
4. Repeat step 3 for left side gusset (17).  
Plate weighs 96 lb (44 kg). Use hoist with lifting capacity of 200 lb (91 kg) to remove plate. Failure to do so could result in injury to personnel.
5. Attach hoist and remove 12 locknuts (14), 24 washers (15), screws (16), and plate (18). Discard locknuts.

REMOVAL - CONTINUED

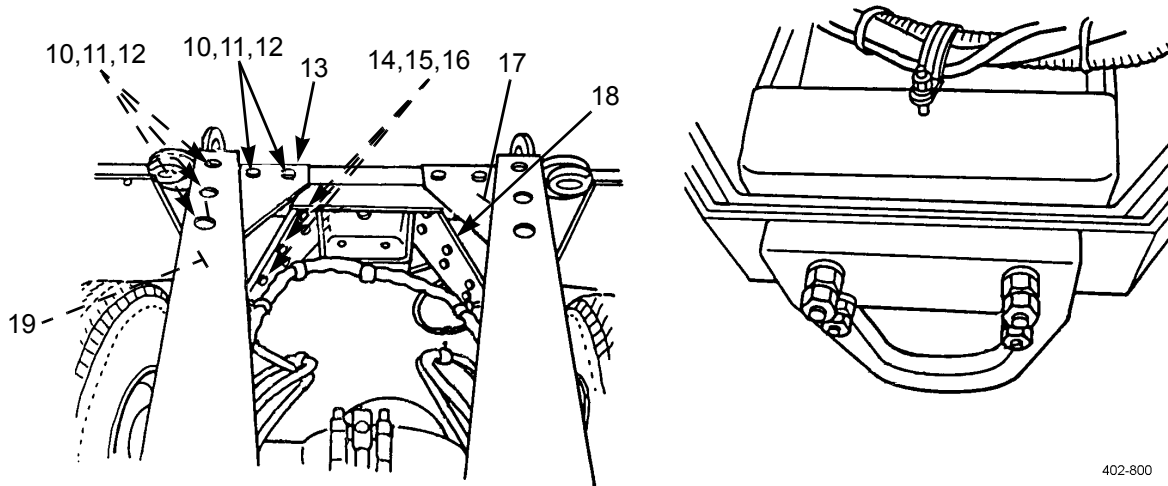

402-800

6. Remove four locknuts (22), eight washers (23), four screws (24), and right side support (20). Discard locknuts.
7. Repeat step 6 for left side support (21).

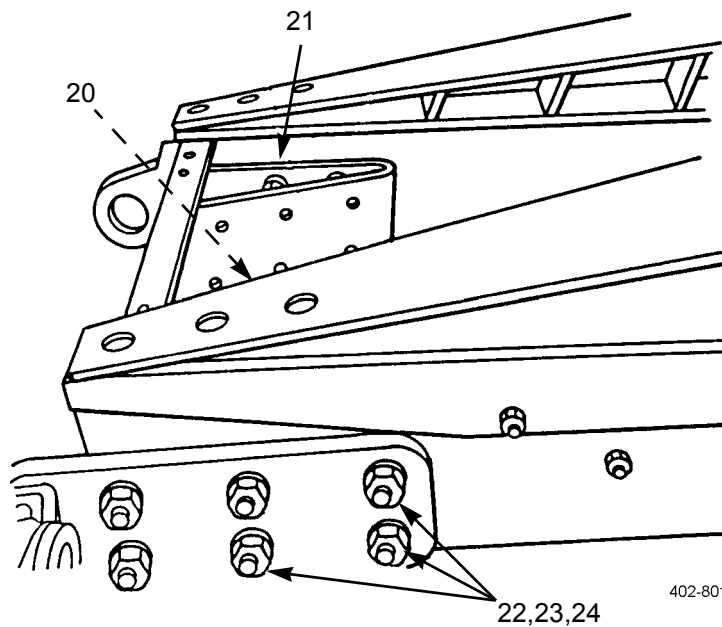

402-801

**REMOVAL - CONTINUED****WARNING**

Rear crossmember weighs 460 lb (209 kg). Use hoist with lifting capacity of 600 lb (272 kg) to remove rear crossmember. Failure to do so could result in injury to personnel.

8. Attach hoist and remove four locknuts (26), eight washers (27), four screws (28), and rear crossmember (25). Discard locknuts.

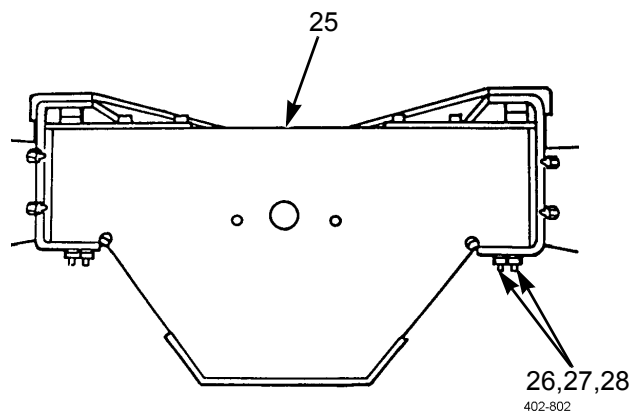
**INSTALLATION****WARNING**

Rear crossmember weighs 460 lb (209 kg). Use hoist with lifting capacity of 600 lb (272 kg) to install rear crossmember. Failure to do so could result in injury to personnel.

1. Install rear crossmember (25) with four screws (28), eight washers (27), and new locknuts (26).
2. Install right side support (20) with four screws (24), eight washers (23), and new locknuts (22).
3. Repeat step 2 for left side support (21).

INSTALLATION - CONTINUED

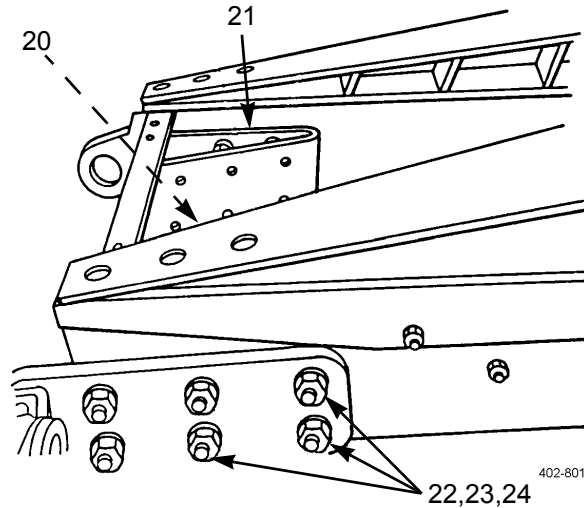

**WARNING**



Plate weighs 96 lb (44 kg). Use hoist with lifting capacity of 200 lb (91 kg) to install plate. Failure to do so could result in injury to personnel.

4. Attach hoist and install plate (18) with 12 screws (16), 24 washers (15), and 12 new locknuts (14).
5. Install right side gusset (13), two spacers (19), five screws (12), ten washers (11), and five new locknuts (10).
6. Repeat step 5 for left side gusset (17).
7. Install reinforcement assembly (5), four screws (8), towing bracket (9), eight washers (7), and eight new locknuts (6).

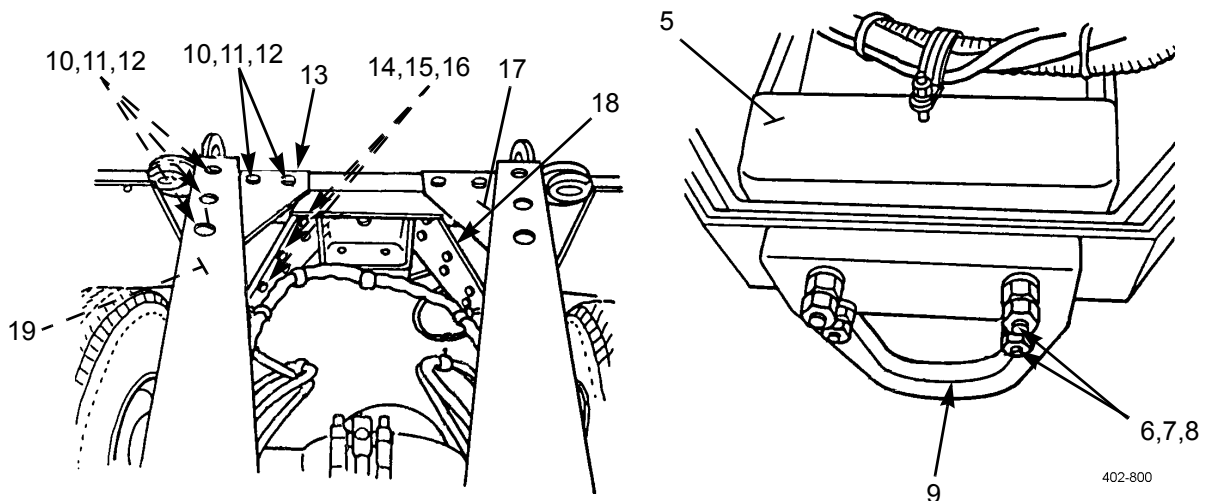

**INSTALLATION - CONTINUED**

8. Move wiring harness (3) into position and install four new tiedown straps (4), clamp (2) and new locknut (1).

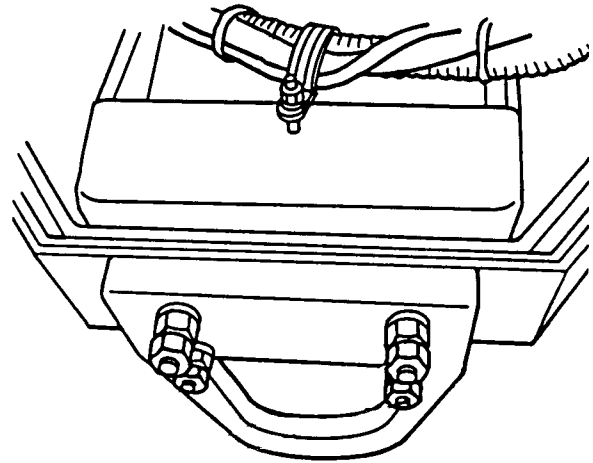
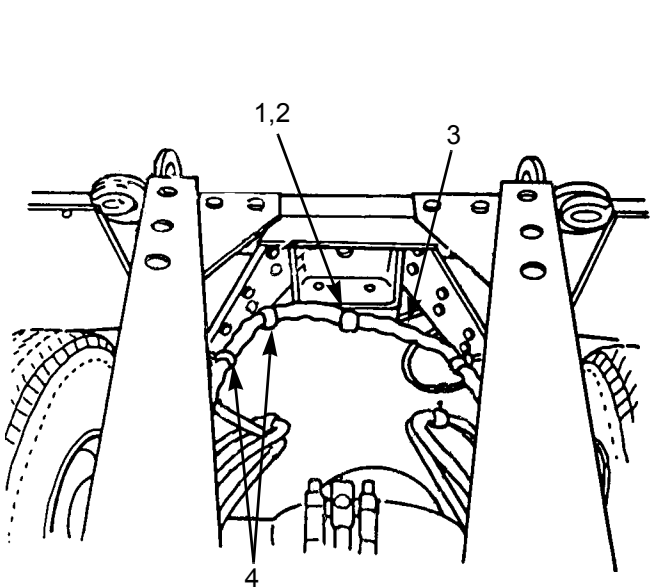

402-800

**NOTE**

Perform steps 9 through 12 for this and other crossmembers.

9. Tighten 1/2-13 grade 8 locknuts to 68 lb-ft (92 Nm).
10. Tighten 5/8-11 grade 8 locknuts to 136 lb-ft (184 Nm).
11. Tighten 3/4-10 grade 8 locknuts to 241 lb-ft (327 Nm).
12. Tighten 1"-8 grade 8 locknuts to 582 lb-ft (789 Nm).
13. Install pintle hook (WP 0168 00).
14. Install taillight brackets (WP 0081 00).

**END OF WORK PACKAGE**



**FRONT CROSSMEMBER REPLACEMENT**

**0277 00**

**THIS WORK PACKAGE COVERS**

Removal, Installation

**INITIAL SETUP**

**Maintenance Level**

General Support

**Personnel Required**

Two

**Tools and Special Tools**

Tool kit, general mechanic's (Item 102, WP 0313 00)

**Equipment Condition**

Radiator removed (WP 0044 00)  
 Front bumper removed (WP 0173 00)  
 Hood removed (WP 0178 00)

**REMOVAL**

1. Remove two nuts (2) and two clamps (3) and set wiring harness (1) aside.
2. Remove two nuts (4), two washers (5), two capscrews (6), two washers (7), two hinge pivots (9), and two spacers (8).

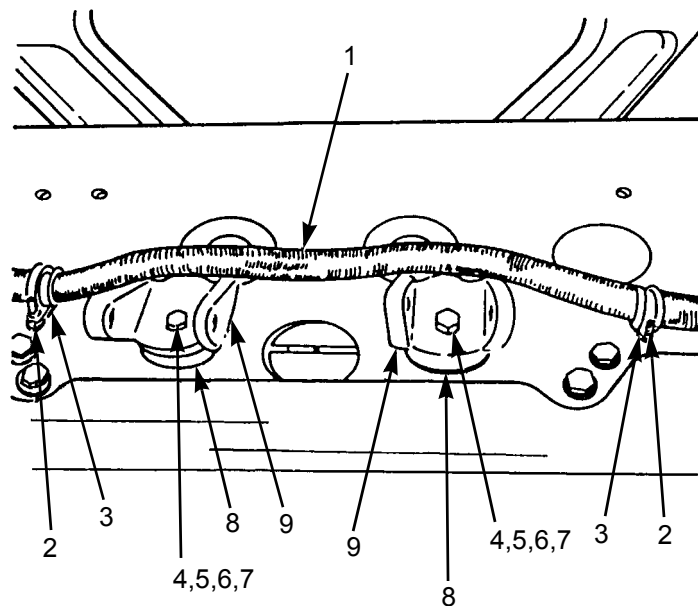

402-803

**REMOVAL - CONTINUED**

**NOTE**

Steps 3 through 6 are for right side of vehicle.

3. Remove six nuts (11), six washers (12), bumper bracket (10), six capscrews (13), and six washers (14).
4. Remove two nuts (15), two washers (16), two capscrews (17), and two washers (18).

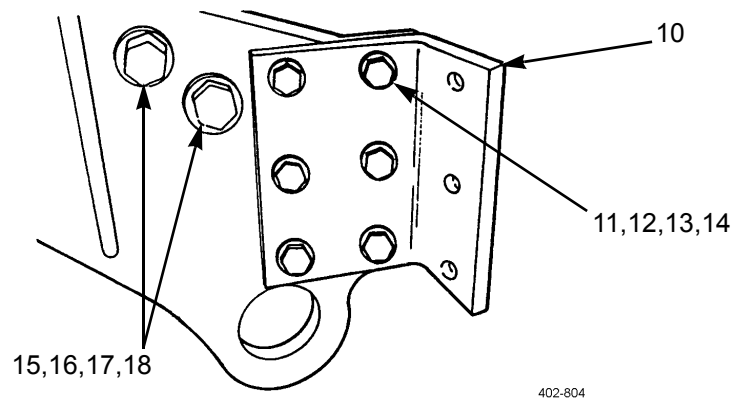

5. Remove two nuts (23), two washers (24), bracket (27), two capscrews (25), and two washers (26).
6. Remove three nuts (19), three washers (20), three capscrews (21), and three washers (22) from front crossmember (28).

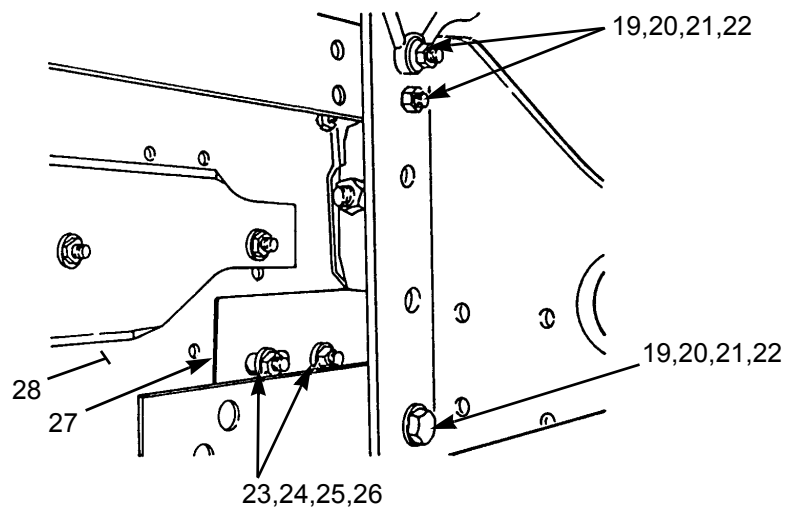

7. Repeat steps 3 through 6 for left side of vehicle.

**REMOVAL - CONTINUED**

8. Remove front crossmember (28).
9. Remove four nuts (33), four washers (32), front crossmember reinforcement (31), four capscrews (29), and four washers (30) from front crossmember (28).

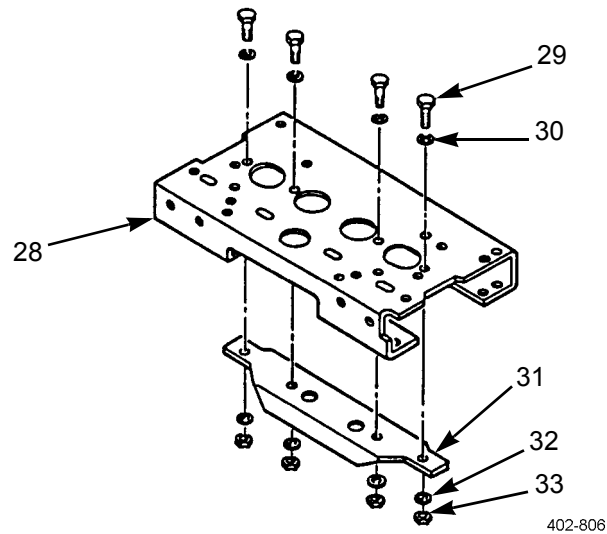
**INSTALLATION**

1. Install four washers (30), four capscrews (29), front crossmember reinforcement (31), four washers (32), and four nuts (33) on front crossmember (28).
2. Install front crossmember (28).

**INSTALLATION - CONTINUED**

**NOTE**

Steps 3 through 6 are for right side of vehicle.

3. Install three washers (19), three capscrews (20), three washers (21), and three nuts (22) on front crossmember (28).
4. Install two washers (23), two capscrews (24), bracket (27), two washers (25), and two nuts (26).

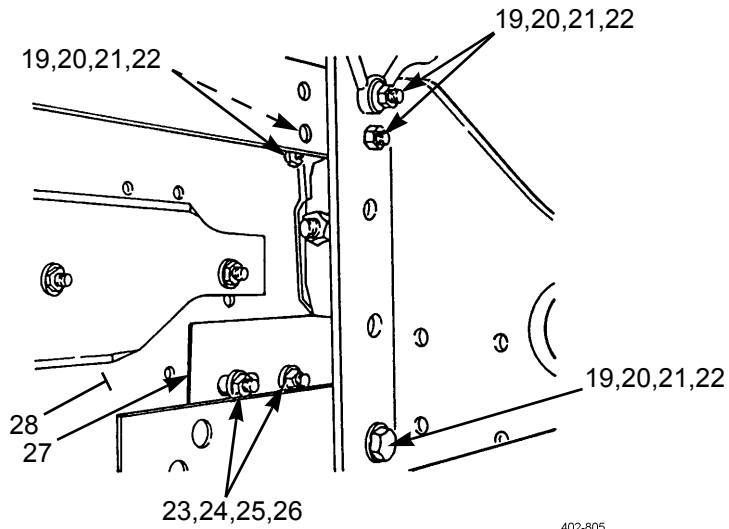

5. Install two washers (15), two capscrews (16), two washers (17), and two nuts (18).
6. Install six washers (11), six capscrews (12), bumper bracket (10), six washers (13), and six nuts (14).

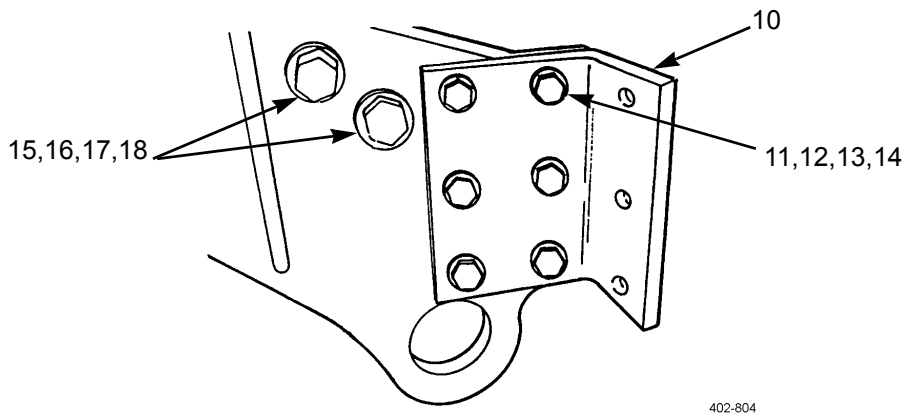

7. Repeat steps 3 through 6 for left side of vehicle.
8. Install two spacers (8), two hinge pivots (9), two washers (4), two capscrews (5), two washers (6), and two nuts (7).
9. Move wiring harness (1) into position and install two clamps (3) and two nuts (2).

**INSTALLATION - CONTINUED**

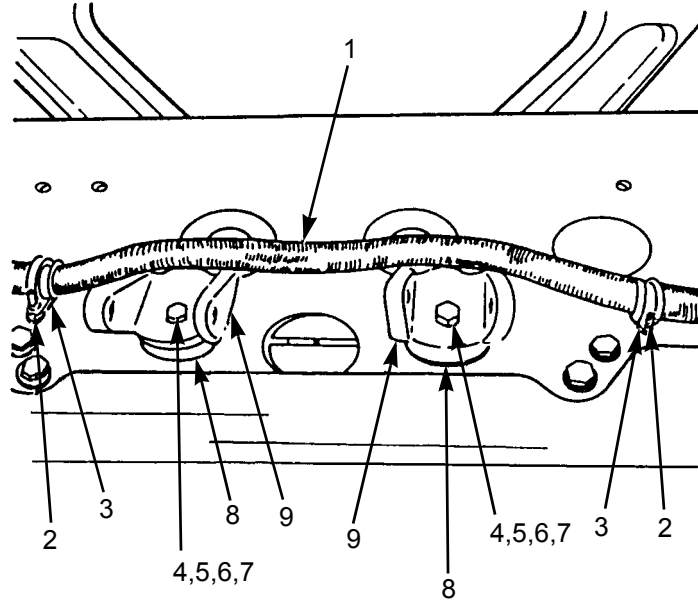

402-803

10. Install front bumper (WP 0173 00).
11. Install radiator (WP 0044 00).
12. Install hood (WP 0178 00).

**END OF WORK PACKAGE**



---

**FRAME RAIL EXTENSION AND REINFORCEMENT REPLACEMENT**

---

**0278 00****THIS WORK PACKAGE COVERS**Removal, Installation

---

**INITIAL SETUP****Maintenance Level**

General Support

**Tools and Special Tools**

Tool kit, general mechanic's (Item 102, WP 0313 00)

**Personnel Required**

Three (minimum)

**Equipment Condition**

Power steering reservoir and hoses removed (WP 0159 00)

Transmission oil cooler removed (WP 0114 00)

Front crossmember removed (WP 0277 00)

Front spring hangers removed (WP 0283 00)

Front engine mount support removed (WP 0279 00)

---

**WARNING**

Frame rail reinforcement weighs 100 lb (45.4 kg). Use minimum of three personnel to remove or install parts from or on frame rail reinforcement. Failure to do so could result in injury to personnel.

**REMOVAL**

**NOTE**

- Steps 1 through 9 are for left side only.
- Steps 10 through 16 are for right side only.

1. Remove nut (5) and clamp (6) from power steering reservoir plate (3).

**NOTE**

Note position of capscrews prior to removal to aid in installation.

2. Remove six nuts (8), six washers (7), six capscrews (20), and six washers (1).
3. Remove power steering reservoir plate (3) from between frame rail reinforcement (11) and frame rail (2).
4. Install any two washers (1), two capscrews (20), two washers (7), and two nuts (8) hand-tight in frame rail reinforcement (11) and frame rail (2).
5. Remove two nuts (17), two washers (16), and two screws (10).
6. Remove three nuts (19), three washers (18), three capscrews (9), and three washers (4).
7. Remove frame rail extension (12) from between frame rail reinforcement (11) and frame rail (2).

**WARNING**

Frame rail reinforcement weighs 100 lb (45.4 kg). Use minimum of three personnel to remove or install parts from or on frame rail reinforcement. Failure to do so could result in injury to personnel.

8. With two personnel holding frame rail reinforcement (11), remove two nuts (8), two washers (7), two capscrews (20), two washers (1), and frame rail reinforcement.

**NOTE**

In steps 9 and 10, note position of capscrews prior to removal to aid in installation.

9. Remove two nuts (22), two washers (21), two capscrews (13), two washers (14), and stiffener (15).

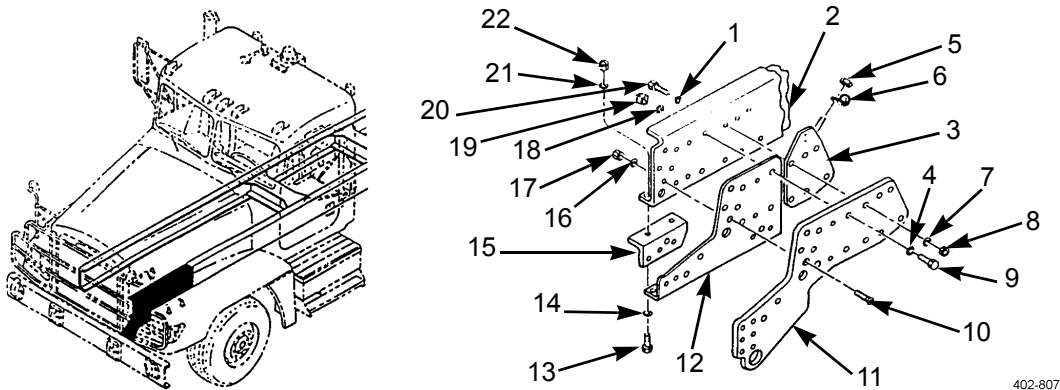

402-807

10. Remove five nuts (23), five washers (38), five capscrews (28), five washers (27), and bracket (40). Set bracket aside.
11. Remove transmission cooler mounting plate (24) from between frame rail reinforcement (36) and frame rail (26).



**REMOVAL - CONTINUED**

12. Install any two washers (27), two capscrews (28), two washers (38), and two nuts (23) hand-tight in frame rail reinforcement (36) and frame rail (26).
13. Remove six nuts (29), six washers (25), six capscrews (39), and six washers (37).
14. Remove frame rail extension (35) from between frame rail reinforcement (36) and frame rail (26).
15. With two personnel holding frame rail reinforcement (36), remove two nuts (23), two washers (38), two capscrews (28), two washers (27), and frame rail reinforcement.

**NOTE**

Note position of capscrews prior to removal to aid in installation.

16. Remove two nuts (30), two washers (31), two capscrews (33), two washers (32), and stiffener (34).

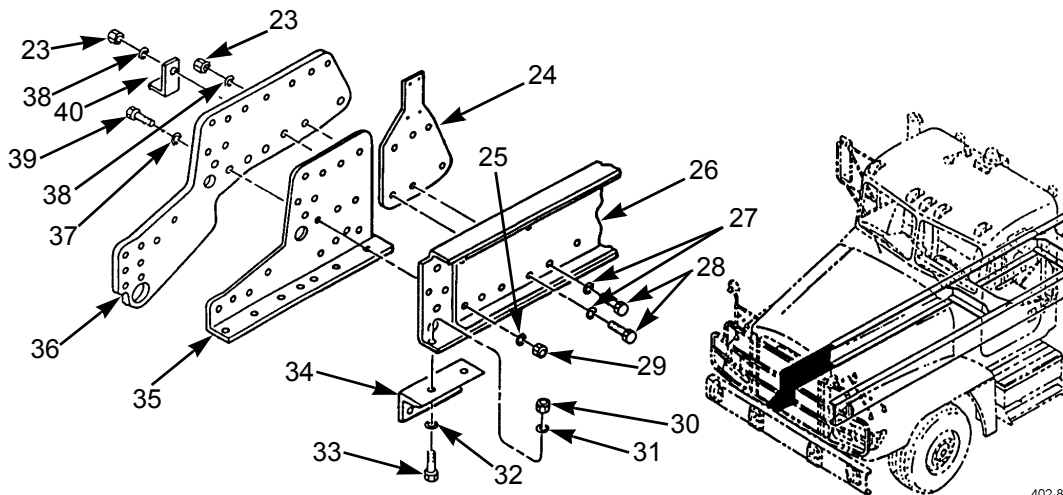

402-808

**INSTALLATION****NOTE**

- Steps 1 through 8 are for right side only.
- Steps 9 through 17 are for left side only.

1. Install stiffener (34), two washers (32), two capscrews (33), two washers (31), and two nuts (30).

**WARNING**

Frame rail reinforcement weighs 100 lb (45.4 kg). Use minimum of three personnel to remove or install parts from or on frame rail reinforcement. Failure to do so could result in injury to personnel.

2. With two personnel holding frame rail reinforcement (36), install two washers (27), two capscrews (28), two washers (38), and two nuts (23) hand-tight.
3. Install frame rail extension (35) between frame rail (26) and frame rail reinforcement (36).
4. Install six washers (37), six capscrews (39), six washers (25), and six nuts (29). Do not tighten nuts.
5. Remove two nuts (23), two washers (38), two capscrews (28), and two washers (27).
6. Install transmission cooler mounting plate (24) between frame rail (26) and frame rail reinforcement (36).
7. Install bracket (40), five washers (27), five capscrews (28), five washers (38), and five nuts (23).
8. Tighten nuts (10 and 16).

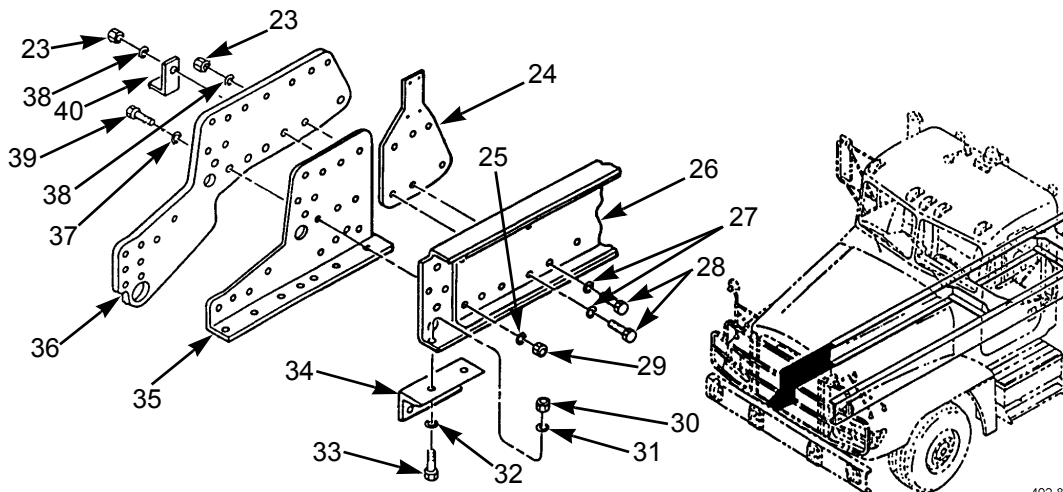

9. Install stiffener (15), two washers (14), two capscrews (13), two washers (21), and two nuts (22).
10. With two personnel holding frame rail reinforcement (11), install two washers (1), two capscrews (20), two washers (7), and two nuts (8) hand-tight.
11. Install frame rail extension (12) between frame rail (2) and frame rail reinforcement (11).
12. Install three washers (4), three capscrews (9), three washers (18), and three nuts (19). Do not tighten nuts.
13. Install two screws (10), two washers (16), and two nuts (17).
14. Remove two nuts (8), two washers (7), two capscrews (20), and two washers (1).
15. Install power steering reservoir plate (3) between frame rail (2) and frame rail reinforcement (11).

**INSTALLATION**

16. Install six washers (1), six capscrews (20), six washers (7), and six nuts (8).
17. Tighten nuts (8 and 19).
18. Install clamp (6) and nut (5) on power steering reservoir plate (3).

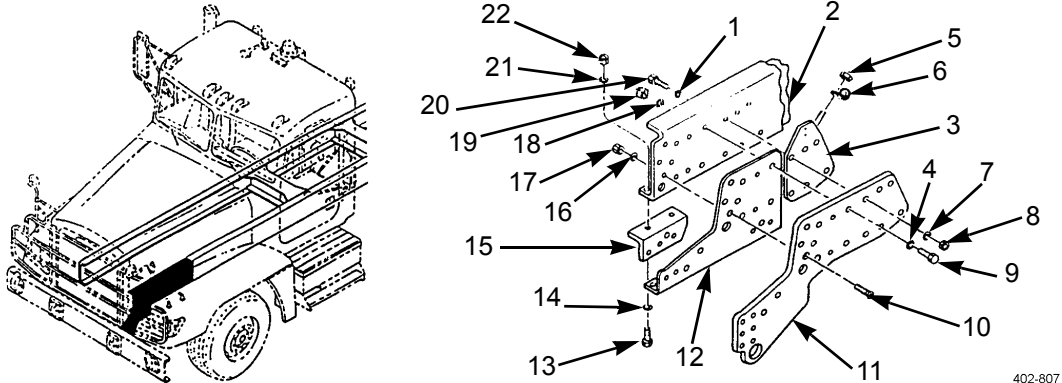

19. Install power steering reservoir and hoses (WP 0159 00).
20. Install transmission oil cooler (WP 0114 00).
21. Install front crossmember (WP 0277 00).
22. Install front spring hangers (WP 0283 00).
23. Install front engine mount support (WP 0279 00).

**END OF WORK PACKAGE**



**FRONT ENGINE MOUNT SUPPORT REPLACEMENT**

**0279 00**

**THIS WORK PACKAGE COVERS**

Removal, Installation

**INITIAL SETUP**

**Maintenance Level**

Direct Support

**Personnel Required**

Two

**Tools and Special Tools**

Tool kit, general mechanic's (Item 102, WP 0313 00)

Jack, hydraulic (Item 52, WP 0313 00)

Trestle, hoist, portable (Item 105, WP 0313 00)

**Equipment Condition**

Front quick-release valve removed (WP 0147 00)

Front crossmember removed (WP 0277 00)

**REMOVAL**

1. Remove four nuts (4), four washers (3), three capscrews (1), three washers (2), and screw (5).

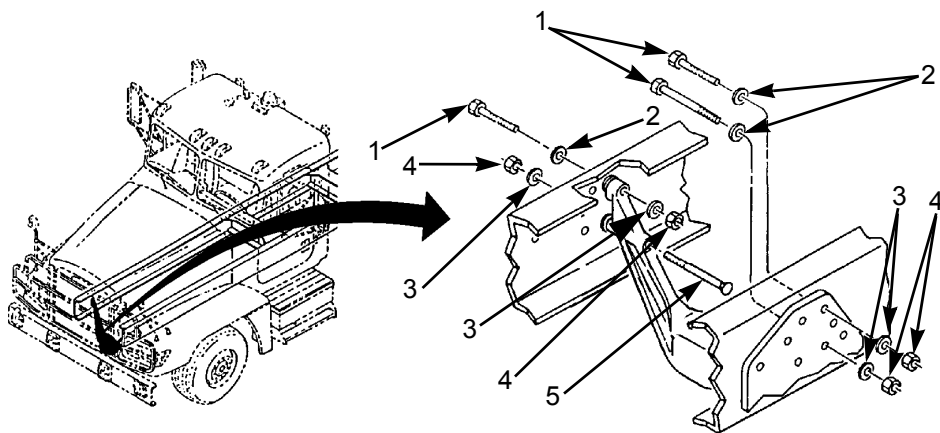

402-809

**FRONT ENGINE MOUNT SUPPORT REPLACEMENT - CONTINUED****0279 00****REMOVAL - CONTINUED**

2. Left side: remove two nuts (7), two washers (8), two capscrews (9), and two washers (10) from frame (6).
3. Repeat step 2 for right side.
4. Remove front engine mount support (12).
5. Remove four spacers (11).

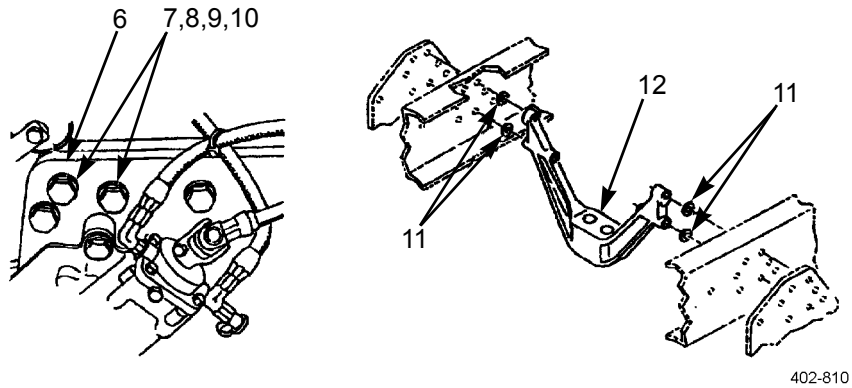
**INSTALLATION**

1. Install front engine mount support (12).
2. Install four spacers (11).
3. Left side: install two washers (7), two capscrews (8), two washers (9), and two nuts (10) on frame (6).
4. Repeat step 3 for right side.

**NOTE**

Make sure spacers installed during step 2 do not slip out of place. If spacer is not present, frame will not be in line to allow installation of front crossmember.

5. Install screw (5), three washers (2), three capscrews (1), four washers (3), and four nuts (4).

**INSTALLATION - CONTINUED**

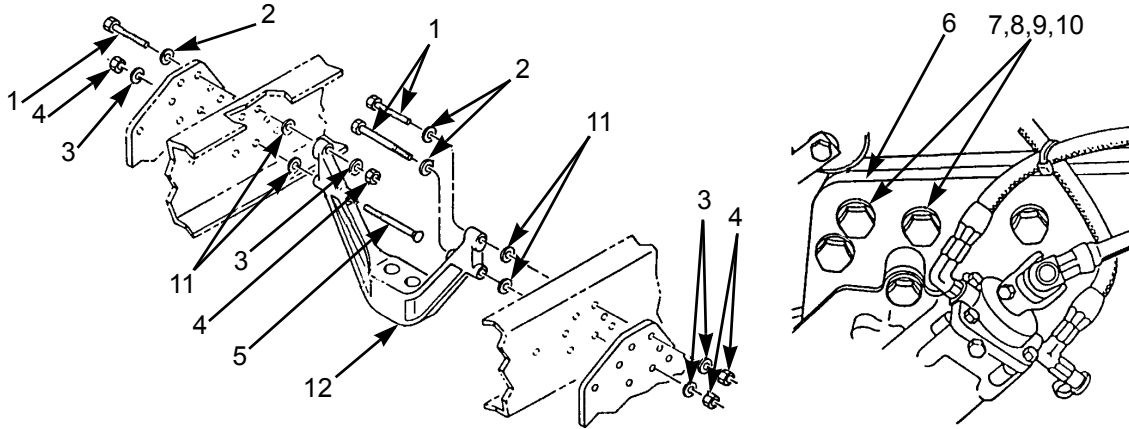

402-811

6. Install front crossmember (WP 0277 00).
7. Install front quick-release valve (WP 0147 00).

**END OF WORK PACKAGE**





**FRONT CAB MOUNTS REPLACEMENT**

**0280 00**

**THIS WORK PACKAGE COVERS**

Removal, Installation

**INITIAL SETUP**

**Maintenance Level**

General Support

**Tools and Special Tools**

Tool kit, general mechanic's (Item 102, WP 0313 00)

Sling, beam type (Item 85, WP 0313 00)

**Materials/Parts**

Clamp, seal (P/N 04-19249-000)

**Materials/Parts - Continued**

Nut, lock (P/N MS51922-1) (4)

Nut, lock (P/N M45913/1-4CG5C) (4)

Nut, lock (P/N M45913/1-12CG5C)

**Personnel Required**

Two

**Equipment Condition**

Fender extension removed (WP 0184 00)



**WARNING**



Use extreme caution when handling heavy parts. Provide adequate support and use assistance during procedure. Ensure that any lifting device used is in good condition and of suitable load capacity. Keep clear of heavy parts supported only by lifting device. Failure to follow this warning may result in death or injury to personnel.

**REMOVAL**

**NOTE**

- Procedure is the same for both sides, except as noted.
- Perform step 1 on right side.

1. Remove seal clamp (1), v-clamp (3), and outlet pipe (2). Discard seal clamp.

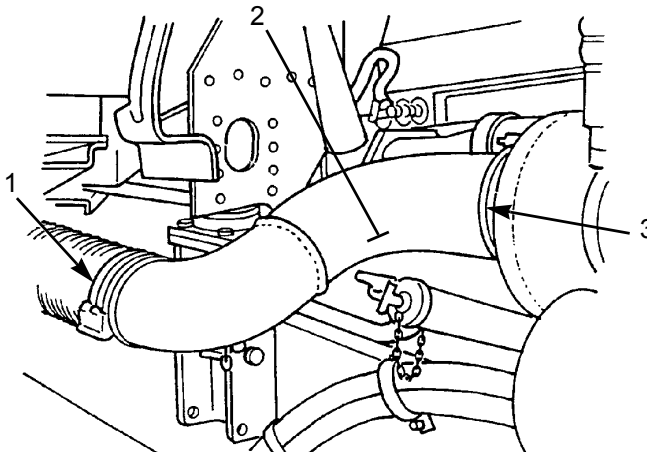

402-812

**REMOVAL - CONTINUED**

2. Remove nut (4), washer (5), bolt (6), and washer (7).

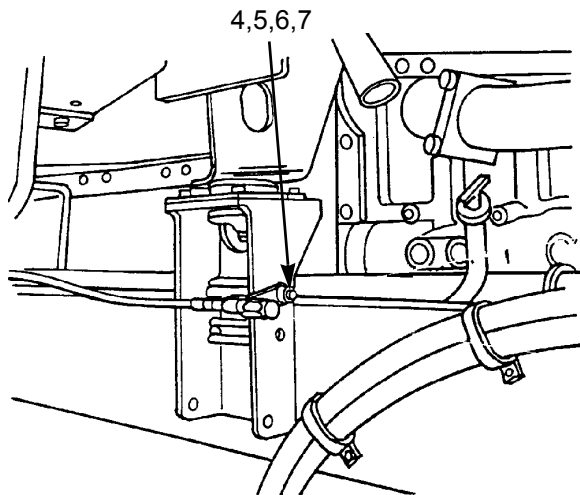

402-813

**NOTE**

Perform step 3 on left side.

3. Remove two locknuts (9), washers (10), screws (11), and four clamps (8). Discard locknuts.

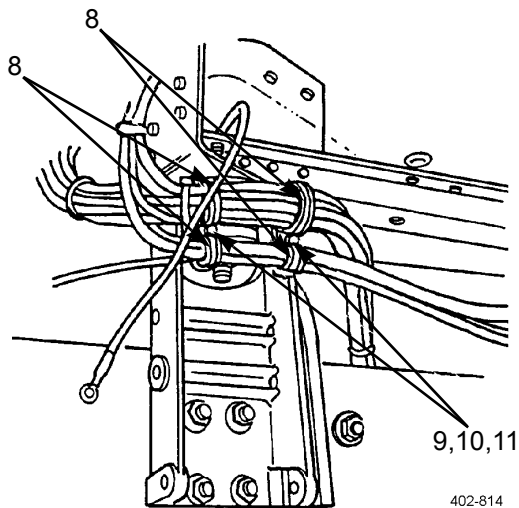

402-814

**REMOVAL - CONTINUED**

**NOTE**

Perform step 4 on left side.

4. Remove locknut (24), washer (25), and screw (26). Disconnect cable (12) and set aside. Discard locknut.
5. Remove locknut (17), washer (16), and resilient mount (15). Discard locknut.



**WARNING**



Cab assembly weighs 1100 lb (499 kg). Use hoist with lifting capacity of 1400 lb (636 kg) to support cab assembly. Failure to do so could result in injury to personnel and/or damage to equipment.

6. Using cab sling and hoist, lift cab assembly (27) enough to remove all slack and not allow cab assembly to drop when front cab mounts (22) are removed.
7. Remove screw (23), washer (13), and bushing (14).
8. Remove four locknuts (18), washers (19), screws (20), washers (21), and front cab mount (22). Discard locknuts.

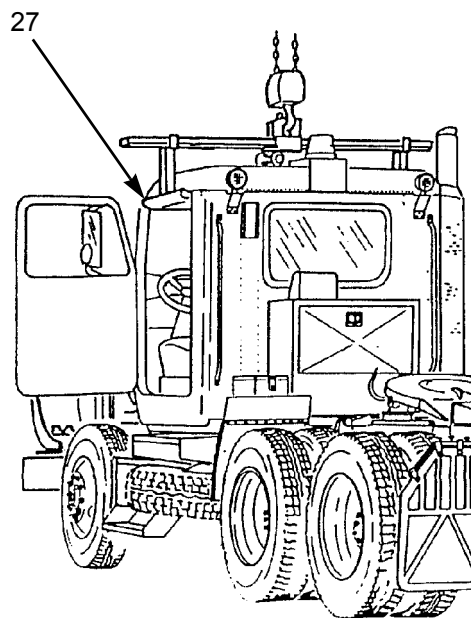
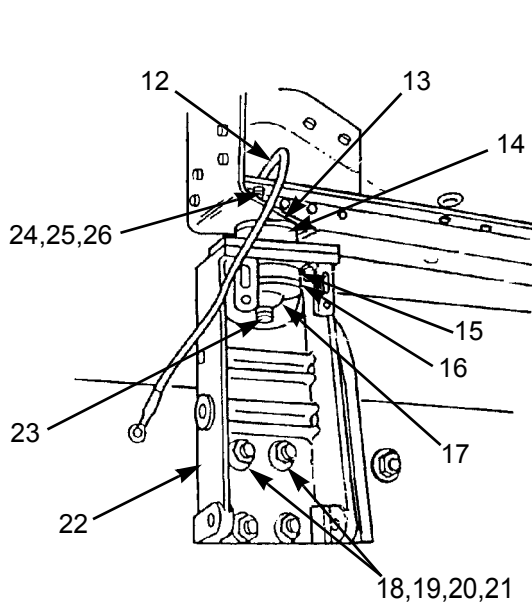

402-815

**REMOVAL - CONTINUED**

**NOTE**

Perform step 9 on left side.

9. Remove three locknuts (28), washers (29), three screws (30), washers (31), and plate (32). Discard locknuts.

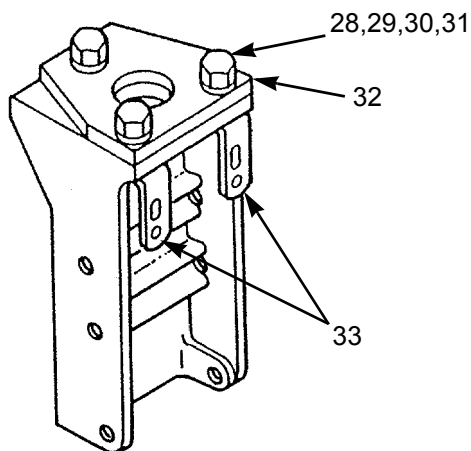

**NOTE**

Perform step 10 on right side.

10. Remove three locknuts (33), washers (34), screws (35), washers (36), and plate (37). Discard locknuts.

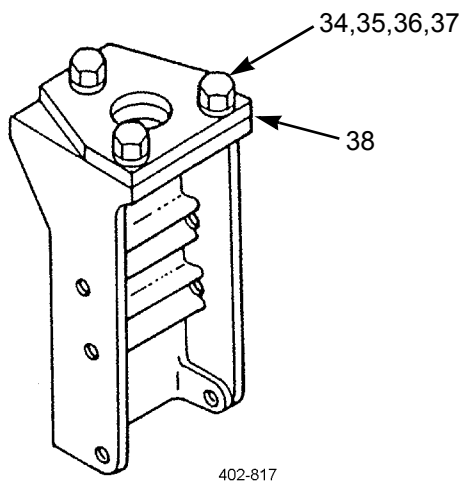

**INSTALLATION**



**WARNING**



Cab assembly weights 1100 lb (499 kg). Use hoist with lifting capacity of 1400 lb (636 kg) to support cab assembly. Failure to do so could result in injury to personnel and/or damage to equipment.

**NOTE**

- Procedure is the same for both sides except as noted.
- Perform step 1 on right side.

1. Install plate (37), three washers (36), screws (35), washers (34), and new locknuts (33).

**NOTE**

Perform step 2 on left side.

2. Install plate (32), three washers (31), screws (30), three washers (29), and new locknuts (28).
3. Install front cab mount (22) with four washers (21), screws (20), washers (19), and new locknuts (18).
4. Install bushing (14), washer (13), and screw (23).
5. Install resilient mount (15), washer (16), and new locknut (17).
6. Lower cab assembly (27) and remove cab sling and hoist.

**NOTE**

Perform steps 7 and 8 on left side.

7. Connect cable (12) and install screw (26), washer (25), and new locknut (24).

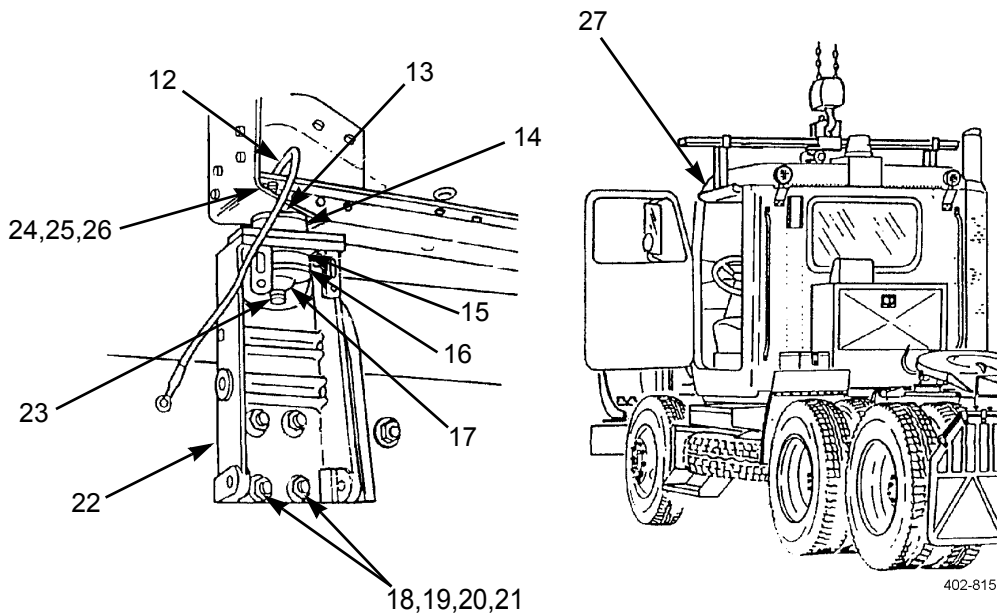

**INSTALLATION - CONTINUED**

8. Install four clamps (8) with two screws (11), washers (10), and new locknuts (9).

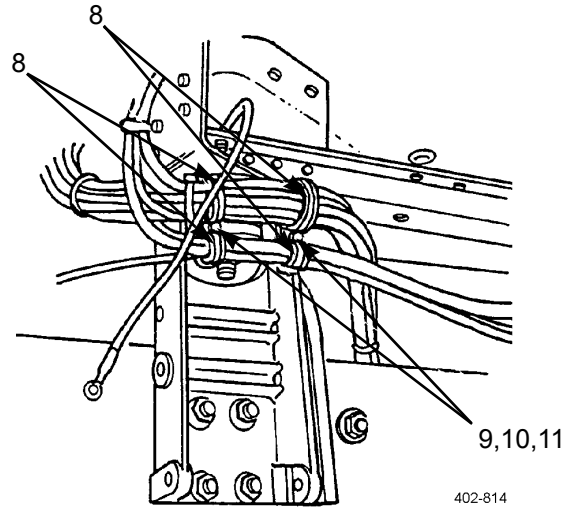

9. Install washer (7), bolt (6), washer (5), and nut (4).

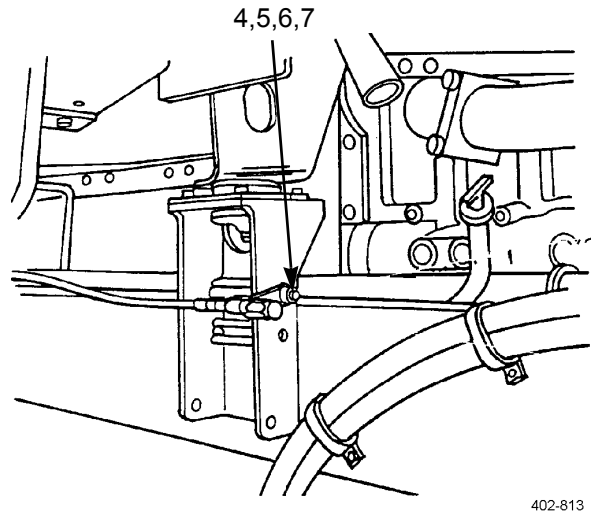

**INSTALLATION - CONTINUED****NOTE**

Perform step 10 on right side.

10. Install outlet pipe (2), v-clamp (3), and new seal clamp (1).
11. Install fender extension (WP 0184 00).

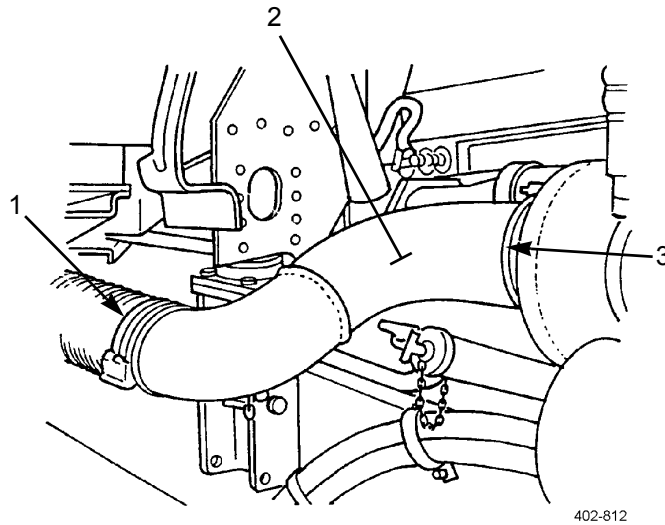

**END OF WORK PACKAGE**





**REAR CAB MOUNTS REPLACEMENT**

**0281 00**

**THIS WORK PACKAGE COVERS**

Removal, Installation

**INITIAL SETUP**

**Maintenance Level**

General Support

**Tools and Special Tools**

Tool kit, general mechanic's (Item 102, WP 0313 00)

Sling, beam type (Item 85, WP 0313 00)

**Materials/Parts**

Nut, lock (P/N M45913/1-6CG5C) (8)

Nut, lock (P/N M45913/1-10CG5C) (2)

**Personnel Required**

Two

**Equipment Condition**

Front cab mounts removed (WP 0280 00)



**WARNING**



- Use extreme caution when handling heavy parts. Provide adequate support and use assistance during procedure. Ensure that any lifting device used is in good condition and of suitable load capacity. Keep clear of heavy parts supported only by lifting device. Failure to follow this warning may result in death or injury to personnel.
- Cab assembly weighs 1100 lb (499 kg). Use hoist with lifting capacity of 1400 lb (636 kg) to support cab assembly. Failure to do so could result in injury to personnel and/or damage to equipment.

**REMOVAL**

1. Remove two locknuts (4) and washers (6). Discard locknuts.
2. Lift cab assembly (2) approximately 5 in (13 cm).
3. Remove two screws (5), washers (3), and resilient mounts (1).

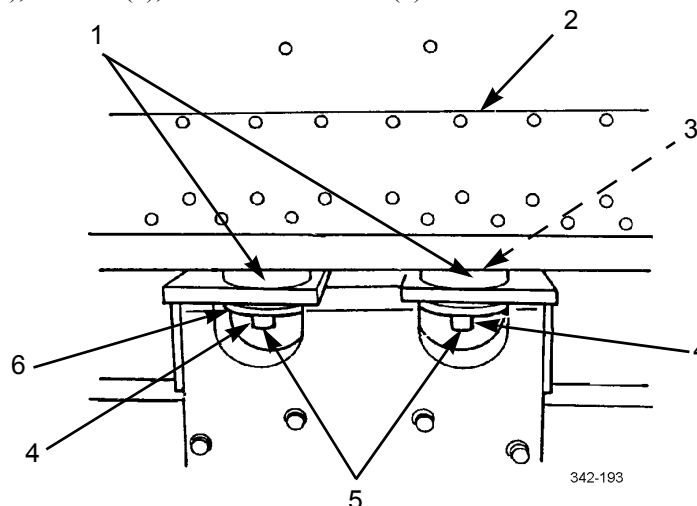

342-193

**REMOVAL - CONTINUED.**

4. Remove eight locknuts (9), screws (10), washers (11), and bracket (7) from inside of cab. Discard locknuts.
5. Remove bracket (8).

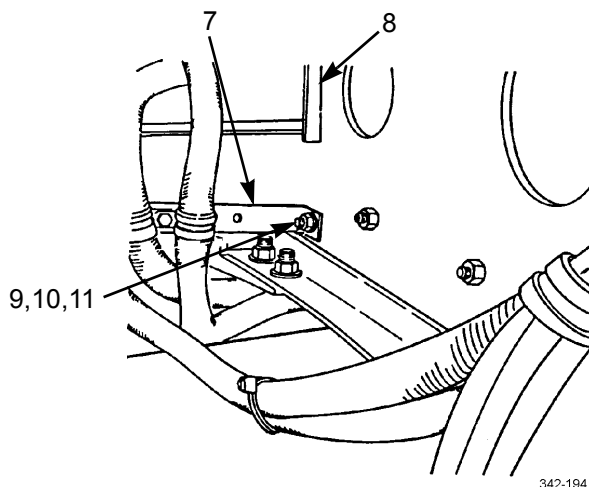

**INSTALLATION**

1. Install bracket (8).
2. Install bracket (7) with eight washers (11), screws (10), and new locknuts (9).
3. Install two resilient mounts (1), washers (3), and screws (5).
4. Lower cab assembly (2) and maintain just enough support to keep slack out of chain.
5. Install two washers (6) and new locknuts (4).
6. Install front cab mounts (WP 0280 00).

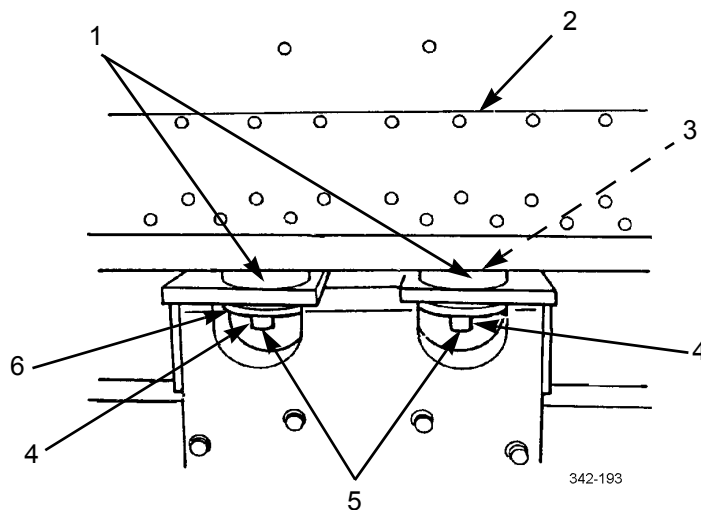

**END OF WORK PACKAGE**

**FRONT SPRING REPLACEMENT**

**0282 00**

**THIS WORK PACKAGE COVERS**

Removal, Installation

**INITIAL SETUP**

**Maintenance Level**

Direct Support

**Tools and Special Tools**

Tool kit, general mechanic's (Item 102, WP 0313 00)

Jack, hydraulic (Item 52, WP 0313 00)

Trestle, hoist, portable (2) (Item 105, WP 0313 00)

Wrench, torque, 15-75 lb-ft (Item 110, WP 0313 00)

Wrench, torque, 100-600 lb-ft (Item 112, WP 0313 00)

**Tools and Special Tools - Continued**

Wrench set, socket, 3/4 in drive (Item 113, WP 0313 00)

**Personnel Required**

Two

**References**

WP 0119 00

**Equipment Condition**

Front wheel removed (TM 9-2320-303-10)

Front shock absorber removed (M915A4R2) (WP 0173 01)



**WARNING**



Use extreme caution when handling heavy parts. Provide adequate support and use assistance during procedure. Ensure that any lifting device used is in good condition and of suitable load capacity. Keep clear of heavy parts supported only by lifting device. Failure to follow this warning may result in death or injury to personnel.

**REMOVAL**

- Using floor jack and two trestles, lift and support frame (1) and front axle (15) to relieve weight from spring (12).

**NOTE**

Axle stop is offset to one side to align with frame. Note position of axle stop prior to removal to aid in installation.

- Remove four nuts (13), washers (14), two U-bolts (2), and axle stop (16) from front axle (15) and spring (12).

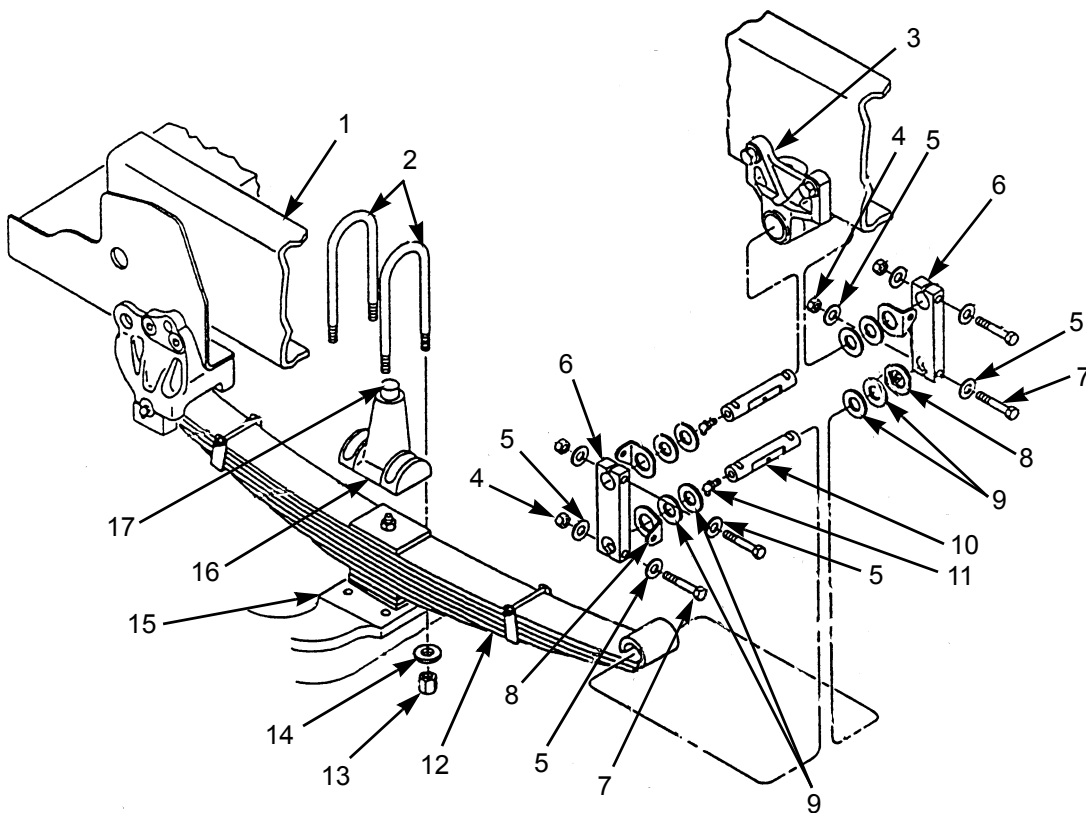

426-039

- Remove stop cushion (17) from axle stop (16) if excessively worn or damaged (WP 0119 00).

**NOTE**

Perform step 4 to separate rear of spring from spring shackles.

- Remove grease fitting (11), two nuts (4), four washers (5), two screws (7), two wear plates (8), four shims (9), and pin (10).
- Repeat step 4 to remove two spring shackles (6) from rear spring hanger (3).

**FRONT SPRING REPLACEMENT - CONTINUED****0282 00****REMOVAL - CONTINUED**

6. Remove grease fitting (26), four screws (27), washers (28), and two saddle caps (18).
7. Lower front axle (15) to allow spring (12) to clear front spring hanger (29). Remove two washers (19), two spacers (20) (M915A4R2), and pin (25) from front of spring.

**NOTE**

Note position and number of shim(s) prior to removal to aid in installation.

8. With assistance, remove spring (12), spacer (24), shock absorber bracket (23) (M915A4R2), shim(s) (22), and pin (21) from front axle (15).

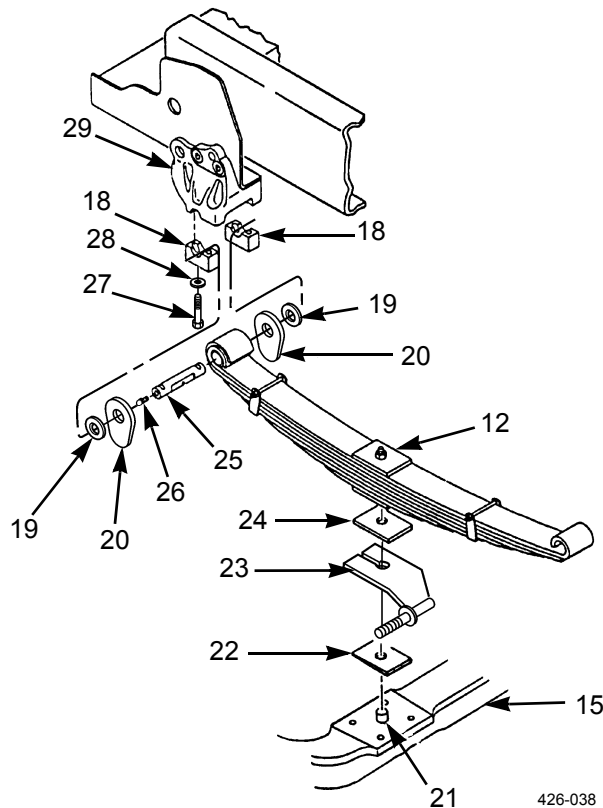
**INSTALLATION****WARNING**

Shim(s) is used to adjust caster alignment. Failure to install shim(s) correctly will cause hard steering and could result in injury to personnel.

**INSTALLATION - CONTINUED**

1. With assistance, install pin (21), shim(s) (22), shock absorber bracket (23) (M915A4R2), spacer (24), and spring (12) on front axle (15).

**NOTE**

Install pin so that grooves line up with holes in shackle, allowing screws to be installed.

2. Install pin (25), two spacers (20) (M915A4R2), and two washers (19) in spring (12).
3. Using floor jack, raise front axle (15) so that front end of spring (12) is positioned in front spring hanger (29). Install two saddle caps (18), four washers (28), screws (27), and grease fitting (26). Tighten screws to 50 lb-ft (68 Nm).

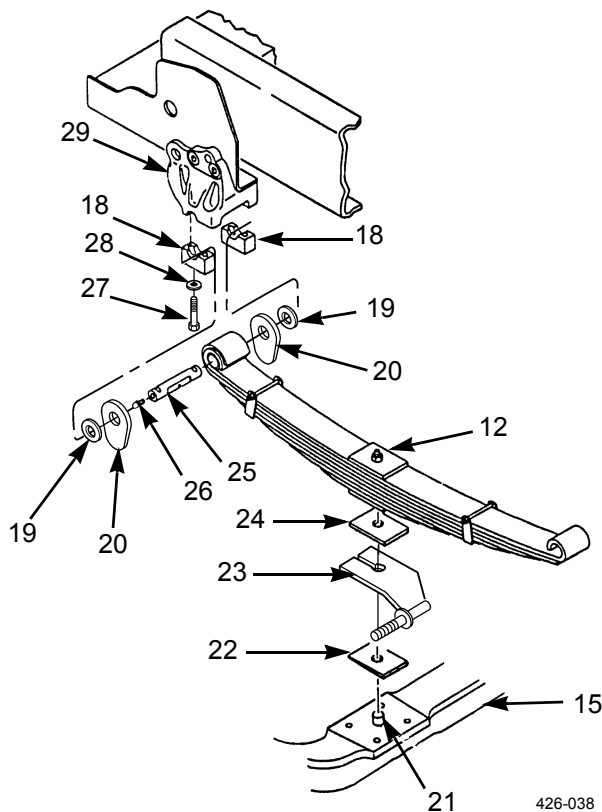

4. Install pin (10), four shims (9), two wear plates (8), shackles (6), washers (5), screws (7), nuts (4), and grease fitting (11) in rear spring hanger (3).
5. Position spring (12) in two shackles (6) and install four shims (9), two wear plates (8), and pin (10).
6. Align grooves in pin (10) with holes in two shackles (6) and check end play. End play should be no more than 1/32 in (0.8 mm). Add shims (9) to correct end play. If possible, add same number of shims on each side of pin.
7. Install four washers (5), two screws (7), two nuts (4), and grease fitting (11).

**CAUTION**

Incorrect installation of axle stop will cause damage to axle and frame during use.

8. Install axle stop (16) in position noted during removal. Install two U-bolts (2), four washers (14), and nuts (13). Tighten nuts to 380-460 lb-ft (515-624 Nm).

**INSTALLATION - CONTINUED**

9. If removed, install stop cushion (17) in axle stop (16) (WP 0119 00).

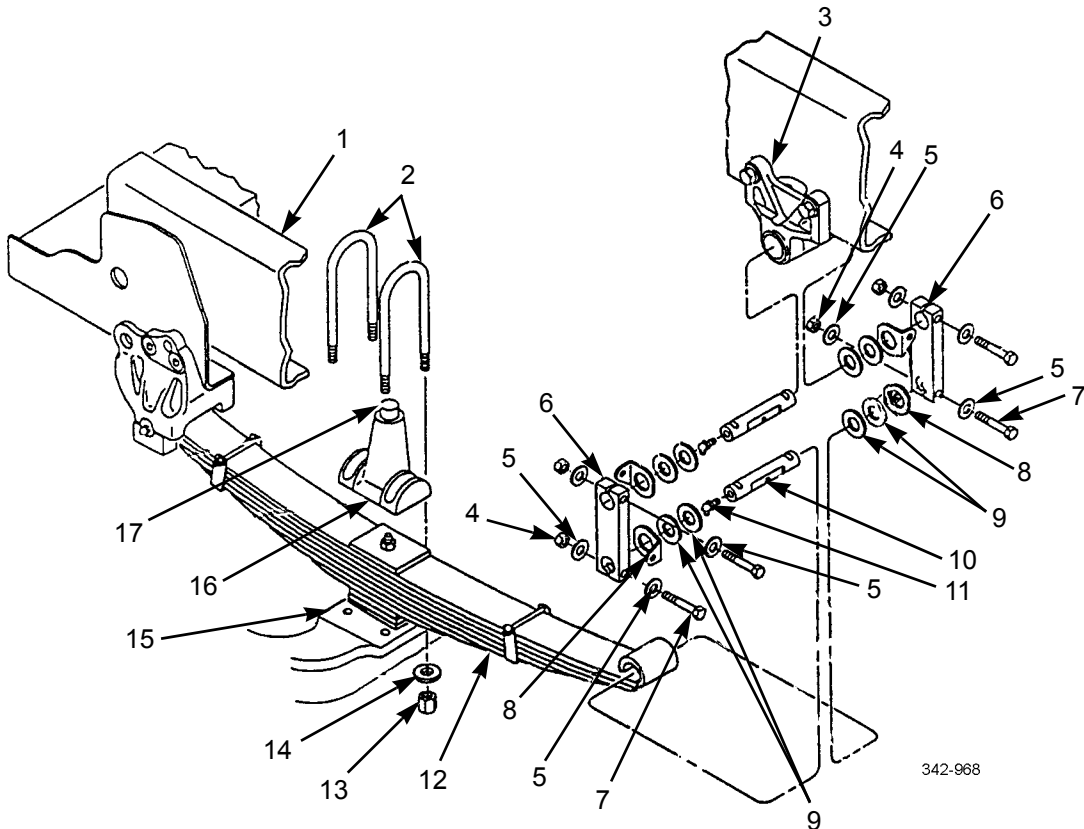

342-968

10. Install front shock absorber (WP 0173 01) (M915A4R2).
11. Install front wheel (TM 9-2320-303-10).

**END OF WORK PACKAGE**





**FRONT SPRING HANGERS REPLACEMENT**

**0283 00**

**THIS WORK PACKAGE COVERS**

Removal, Installation

**INITIAL SETUP**

**Maintenance Level**

Direct Support

**Tools and Special Tools**

Tool kit, general mechanic's (Item 102, WP 0313 00)

Wrench, torque, 50-250 lb-ft (Item 111, WP 0313 00)

**Materials/Parts**

Nut, lock (P/N M45913/1-8CG5C)

**Equipment Condition**

Front spring removed (WP 0282 00)

Steering gear removed (left side only) (WP 0265 00)

**REMOVAL**

**NOTE**

- Vehicle may utilize huckbolts instead of screws and nuts. Replace all loose or damaged huckbolts with grade 8 screws and locknuts.
- Perform steps 1 through 3 on left-front side of vehicle.

1. Remove two locknuts (1), washers (2), screws (4), and threaded block (3). Discard locknuts.

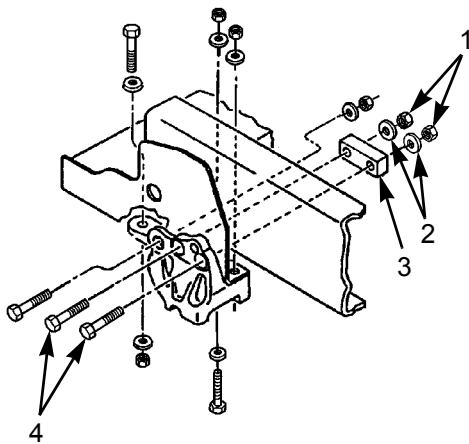

LEFT-FRONT

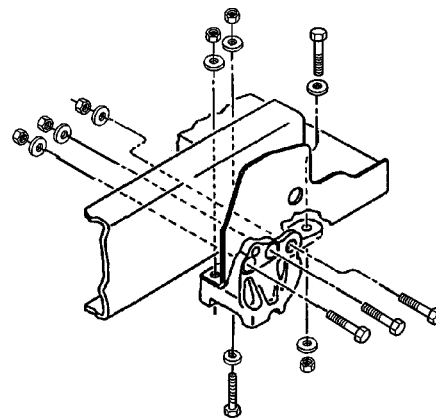

RIGHT-FRONT

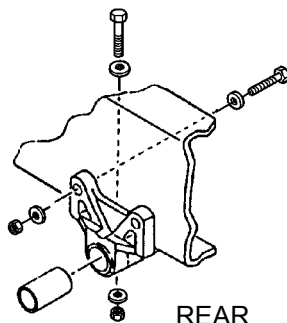

REAR

402-822

**FRONT SPRING HANGERS REPLACEMENT - CONTINUED**

**0283 00**

**REMOVAL - CONTINUED**

2. Remove locknut (9), washer (8), and screw (12). Discard locknut.
3. Remove three locknuts (6), six washers (5), left-front spring hanger (11), and three screws (10) from frame (7). Discard locknuts.

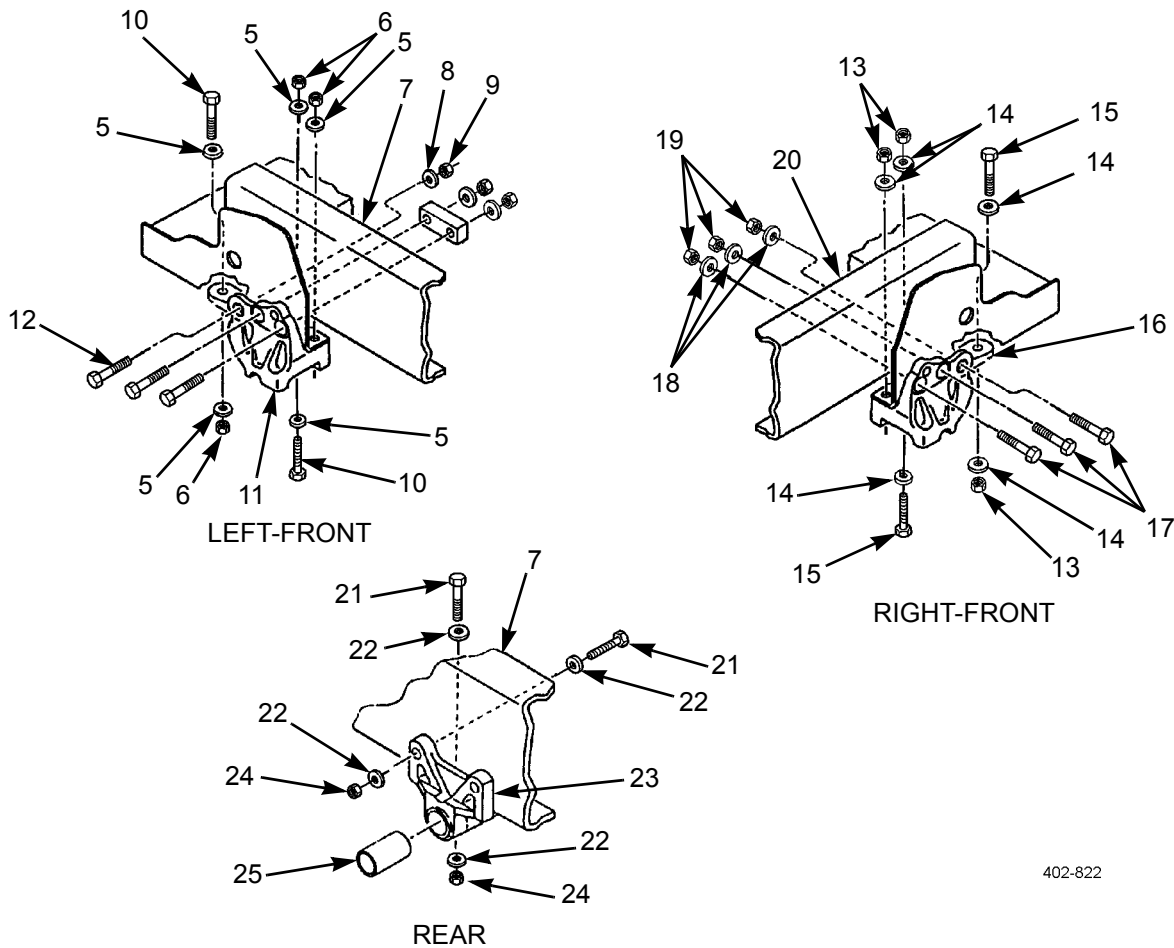

402-822

**NOTE**

Perform steps 4 and 5 on right-front side of vehicle.

4. Remove three locknuts (19), washers (18), and screws (17).
5. Remove three locknuts (13), six washers (14), right-front spring hanger (16), and three screws (15) from frame (20). Discard locknuts.

**NOTE**

Perform steps 6 and 7 for each of two rear spring hangers.

6. Remove four locknuts (23), washers (22), screws (21), and rear spring hanger (23) from frame (7). Discard locknuts.
7. If damaged, remove bushing (25) from rear spring hanger (23).

**INSTALLATION****NOTE**

Perform steps 1 and 2 for each of two rear spring hangers.

1. If removed, install new bushing (25) in rear spring hanger (23).
2. Install four washers (22), screws (21), rear spring hanger (23), four washers (22), and new locknuts (24) on frame (7).

**NOTE**

Perform steps 3 and 4 on right-front side of vehicle.

3. Install six washers (14), screws (15), right-front spring hanger (16), and new locknuts (13) on frame (20).
4. Install three screws (17), washers (18), and new locknuts (19).

**NOTE**

Perform steps 5 through 7 on left-front side of vehicle.

5. Install six washers (5), screws (10), left-front spring hanger (11), and new locknuts (6).
6. Install screw (12), washer (8), and new locknut (9).
7. Install threaded block (3), two screws (4), washers (2), and new locknuts (1).
8. Tighten 5/8-11 grade 8 locknuts to 160 lb-ft (217 Nm).
9. Install steering gear (left side only) (WP 0265 00).
10. Install front spring (WP 0282 00).

**END OF WORK PACKAGE**



**REAR SPRING AND SADDLE ASSEMBLY REPLACEMENT****0284 00****THIS WORK PACKAGE COVERS**

Removal, Installation

**INITIAL SETUP****Maintenance Level**

Direct Support

**Tools and Special Tools**

Tool kit, general mechanic's (Item 102, WP 0313 00)

**Tools and Special Tools - Continued**

Trestle, hoist, portable (Item 105, WP 0313 00)

**Equipment Condition**

Equalizing beam removed (WP 0287 00)

**REMOVAL****WARNING**

Spring and saddle assembly weighs 420 lb (190 kg). Use floor jack to lift and support spring and saddle assembly. Failure to do so could result in injury to personnel.

1. Using floor jack, support spring and saddle assembly (10).
2. Remove two nuts (1), two washers (3), two screws (4), two washers (3), and pin (12) from forward mounting bracket (2).
3. Remove fitting (13) from pin (12).
4. Remove nut (5), two washers (6), screw (8), and spacer (9) from rear mounting bracket (7).
5. Lower spring and saddle assembly (10) and remove spacer (11).

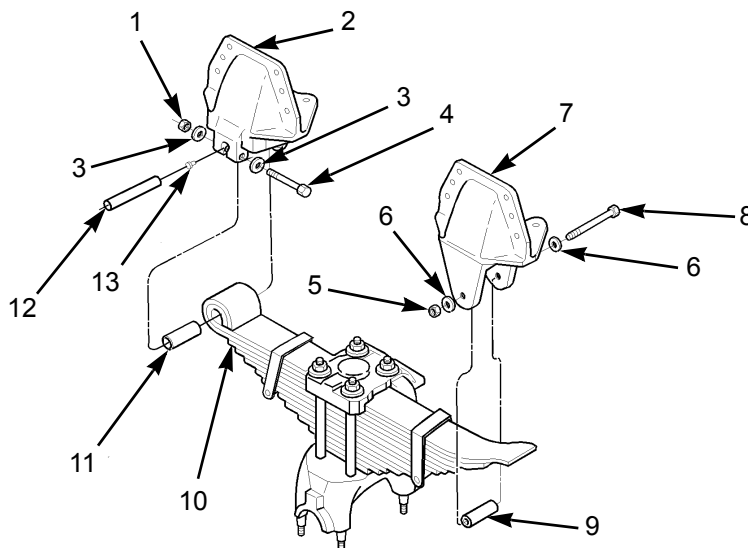

402-823

**INSTALLATION**

1. Install spacer (11).

**WARNING**

Spring and saddle assembly weighs 420 lb (190 kg). Use floor jack to lift and support spring and saddle assembly. Failure to do so could result in injury to personnel.

2. Using floor jack, raise spring and saddle assembly (10) into position.
3. Install spacer (9), screw (8), two washers (6), and nut (5) in rear mounting bracket (7).
4. Install fitting (13) in pin (12).
5. Install pin (12), two washers (3), two screws (4), two washers (14), and two nuts (1) in forward mounting bracket (2).

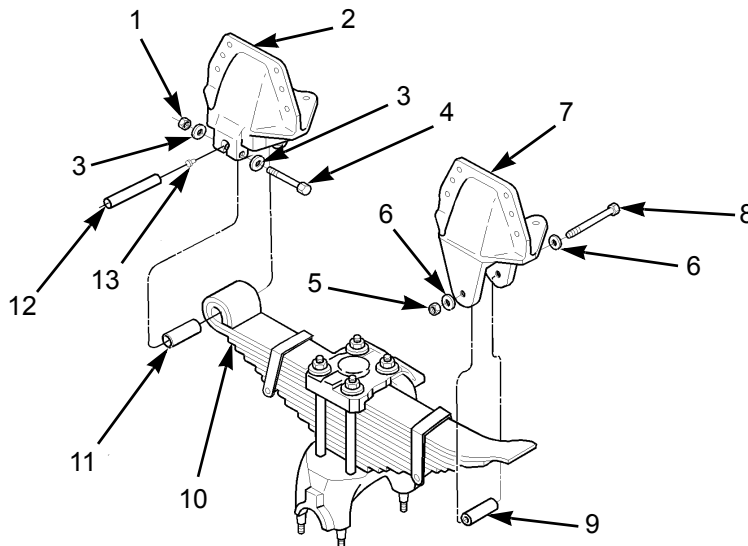

402-823

6. Install equalizing beam (WP 0287 00).

**END OF WORK PACKAGE**

**REAR SPRING HANGER REPLACEMENT**

**0285 00**

**THIS WORK PACKAGE COVERS**

Removal, Installation

**INITIAL SETUP**

**Maintenance Level**

Direct Support

**Tools and Special Tools**

Tool kit, general mechanic's (Item 102, WP 0313 00)

**Tools and Special Tools - Continued**

Wrench, torque, 50-250 lb-ft (Item 111, WP 0313 00)

**Equipment Condition**

Rear spring and saddle assembly removed (WP 0284 00)

**REMOVAL**

**NOTE**

Procedure is the same for both front and rear spring hangers.

Remove eight nuts (5), eight washers (4), eight screws (2), eight washers (3), two spacers (1), spring hanger (6), and spacer (7).

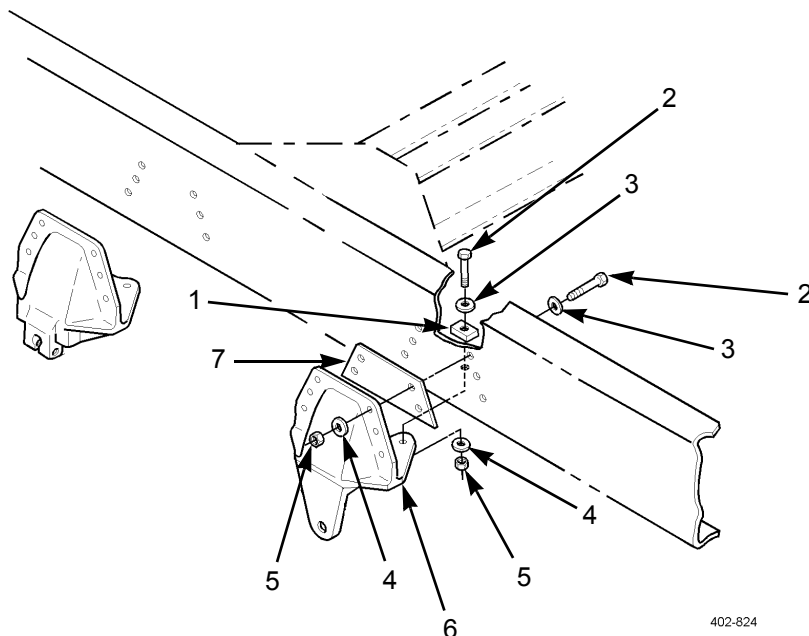

402-824

**INSTALLATION****NOTE**

Procedure is the same for both front and rear spring hangers.

1. Install spacer (7), spring hanger (6), two spacers (1), eight washers (3), eight screws (2), eight washers (4), and eight nuts (5). Tighten nuts to 62-84 lb-ft (84-114 Nm).

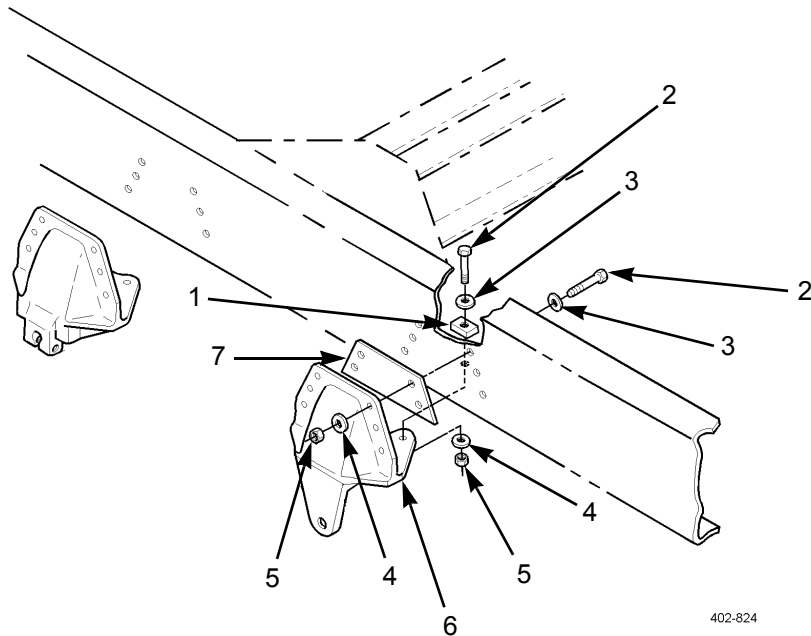

2. Install rear spring and saddle assembly (WP 0284 00).

**END OF WORK PACKAGE**



**TORQUE ROD REPLACEMENT**

**0286 00**

**THIS WORK PACKAGE COVERS**

Removal, Installation

**INITIAL SETUP**

**Maintenance Level**

Direct Support

**Tools and Special Tools**

Tool kit, general mechanic's (Item 102, WP 0313 00)

**Tools and Special Tools - Continued**

Shop equipment, automotive (Item 81, WP 0313 00)

**Equipment Condition**

Vehicle blocked (TM 9-2320-303-10)

**NOTE**

Using suitable jackstands, support the input yoke of forward-rear axle and input yoke of rear axle to prevent rotation of axles as torque rods are replaced.

**REMOVAL**

**NOTE**

In steps 1 and 2, mark spacer washers before removal to aid in installation.

1. Remove two nuts (1), washers (2), screws (6), washers (5), and spacer washers (4) to disconnect torque rod (7) from rear axle (3).
2. Remove two nuts (14), washers (13), screws (9), washers (10), and spacer washers (11) to disconnect torque rod (15) from forward-rear axle (12).
3. Remove two nuts (16), washers (17), screws (21), washers (20), torque rods (7 and 15), and mounting brackets (18 and 19) from frame crossmember (8).

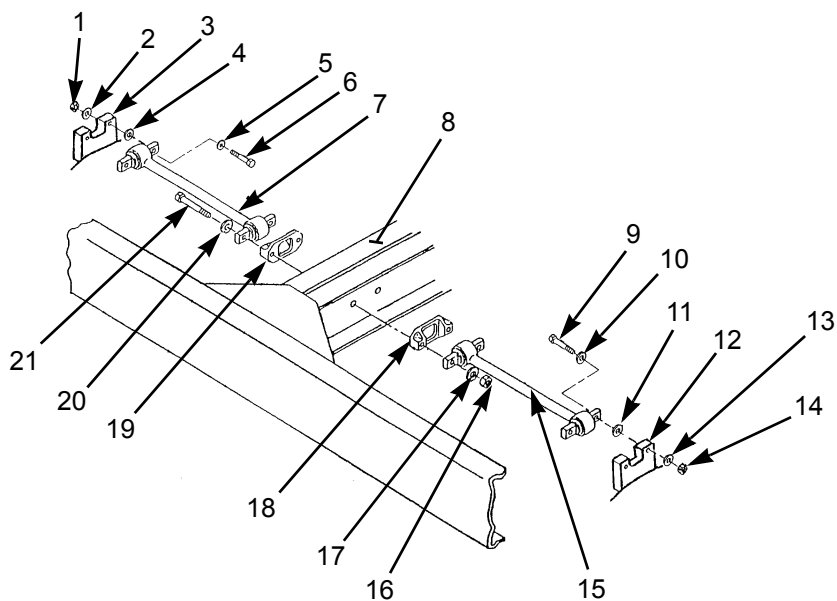

402-825

**TORQUE ROD REPLACEMENT - CONTINUED**

**0286 00**

**INSTALLATION**

1. Install two mounting brackets (18 and 19) and torque rods (7 and 15) to frame crossmember (8) with two washers (20), screws (21), washers (17), and nuts (16).
2. Connect torque rod (15) to forward-rear axle (12) with two spacer washers (11), washers (10), screws (9), washers (13), and nuts (14).
3. Connect torque rod (7) to rear axle (3) with two spacer washers (4), washers (5), screws (6), washers (2), and nuts (1).

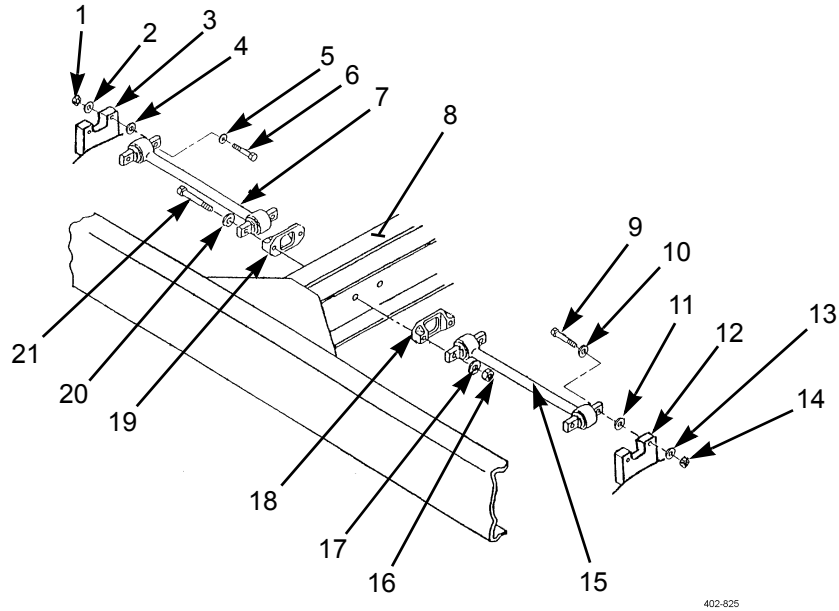

402-825

**END OF WORK PACKAGE**

**THIS WORK PACKAGE COVERS**

Removal, Installation

**INITIAL SETUP**

**Maintenance Level**

Direct Support

**Tools and Special Tools**

Tool kit, general mechanic's (Item 102, WP 0313 00)

Shop equipment, automotive (Item 81, WP 0313 00)

**Tools and Special Tools - Continued**

Trestle, hoist, portable (Item 105, WP 0313 00)

**Materials/Parts**

Adapters (P/N 45163) (8)

**Equipment Condition**

Air system drained (TM 9-2320-303-10)

Rear brakeshoe and linings removed (WP 0124 00)

**REMOVAL**

1. Using suitable lifting device and jack stands, lift and support rear of vehicle so that weight is relieved from both rear springs (3).
2. Position jack stand to support input yoke (1) of forward-rear axle (2). Position jack stand to support input yoke (4) of rear axle (5).

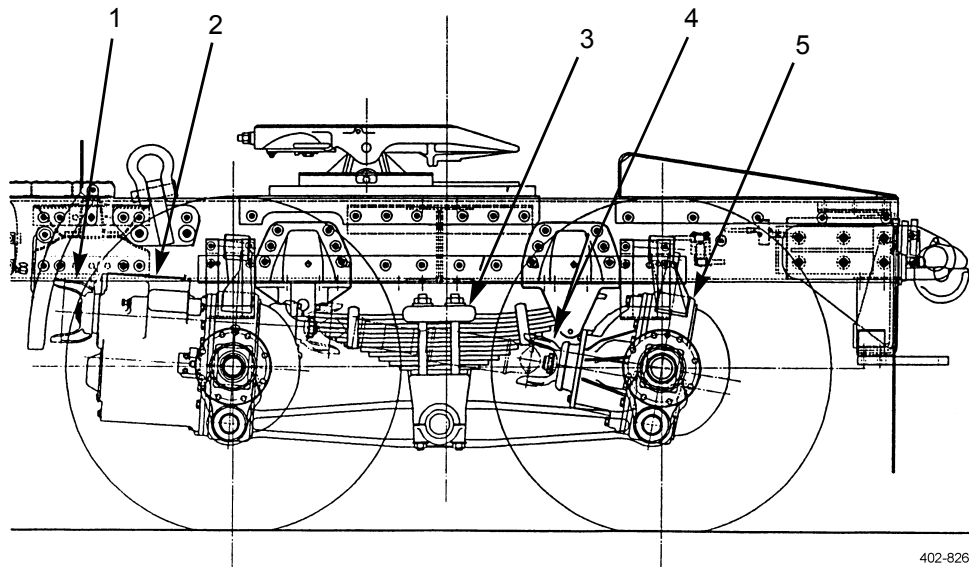

402-826

**REMOVAL - CONTINUED****NOTE**

Steps 3 through 5 are for rear axle.

3. Remove four air hoses (11) from rear brake chambers (10).

**NOTE**

Spider assembly consists of air brake chamber, S-cam, and slack adjuster.

4. Remove 16 nuts (6), 16 washers (7), 16 screws (8), 16 washers (9), and two spider assemblies (12) from both sides of rear axle (5).
5. Using suitable floor jack, support rear axle (5).
6. Repeat steps 3 through 5 for forward-rear axle (2).

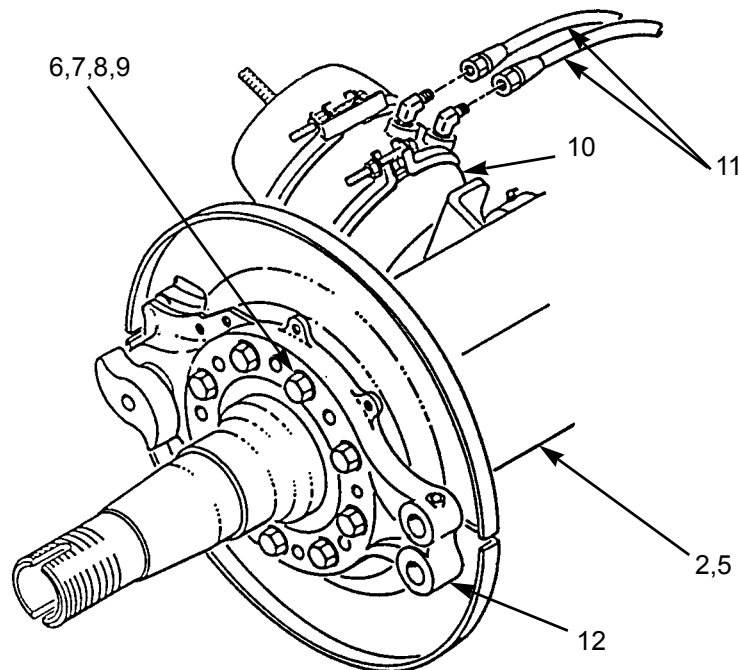

402-643

7. Remove eight nuts (22), eight washers (23), and four saddle caps (20) from two spring assemblies (3).
8. Using block of wood and jack stand, support rear ends of two equalizing beams (17). Remove two nuts (19), two washers (18), two screws (15), two washers (14), and four adapters (13) from rear end of two equalizing beams. Discard adapters.
9. Lower rear ends of two equalizing beams (17) onto blocks.
10. Repeat steps 8 and 9 for front end of two equalizing beams (17).
11. Remove four intermediate tubes (21) from two equalizing beams (17).

**REMOVAL - CONTINUED**

12. Remove one equalizing beam (17) from blocks and remove crosstube (16) from other equalizing beam.

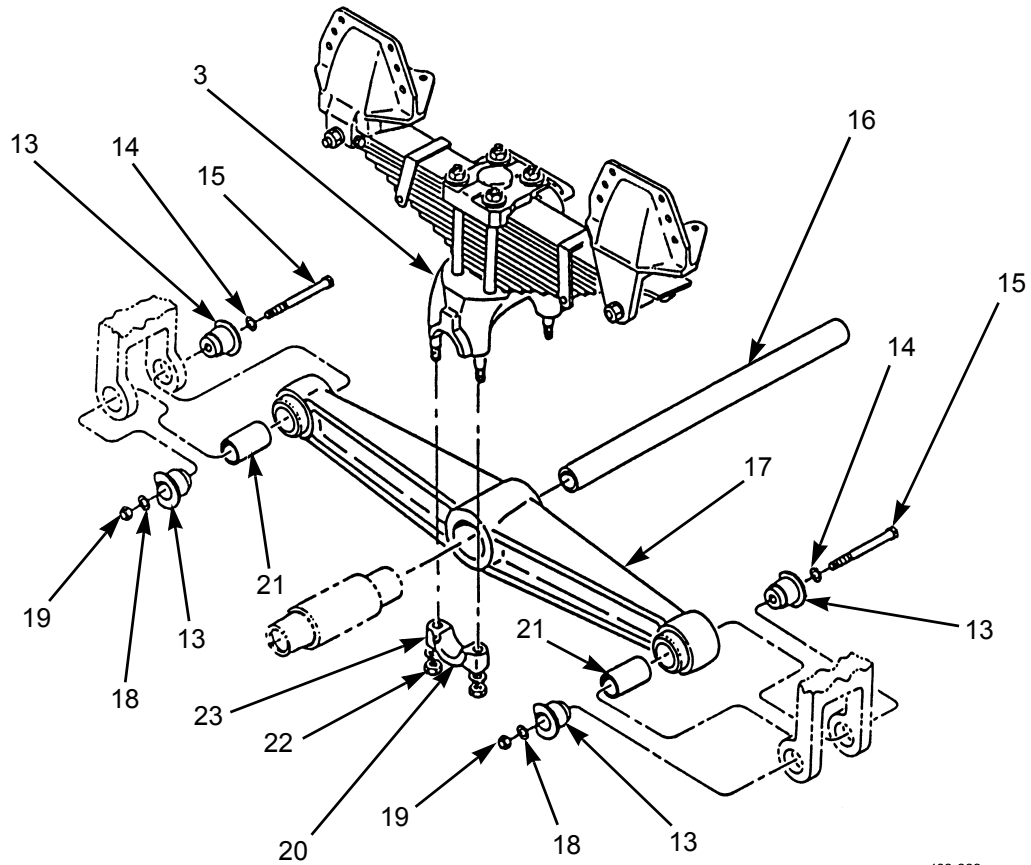

402-828

**INSTALLATION****WARNING**

Make sure all air lines and fittings are clear of debris. Failure to do so could result in equipment failure and/or injury to personnel.

1. Install four intermediate tubes (21) in two equalizing beams (17).
2. Position one equalizing beam (17) on blocks under vehicle and install crosstube (16).
3. Install second equalizing beam (17) on crosstube (16) and blocks under vehicle.

**NOTE**

Rotate adapters so flat side is vertical. Do not tighten adapters until both ends are installed.

4. Using block of wood and jack stand, raise rear ends of two equalizing beams (17). Install four new adapters (13), two washers (14), two screws (15), two washers (18), and two nuts (19) hand-tight.
5. Repeat step 4 for front end of two equalizing beams (17) in forward-rear axle (2).
6. Tighten four nuts (19) to 210-240 lb-ft (285-325 Nm).
7. Install four saddle caps (20), eight washers (23), and eight nuts (22) on two spring assemblies (3). Tighten nuts to 225-275 lb-ft (305-373 Nm).

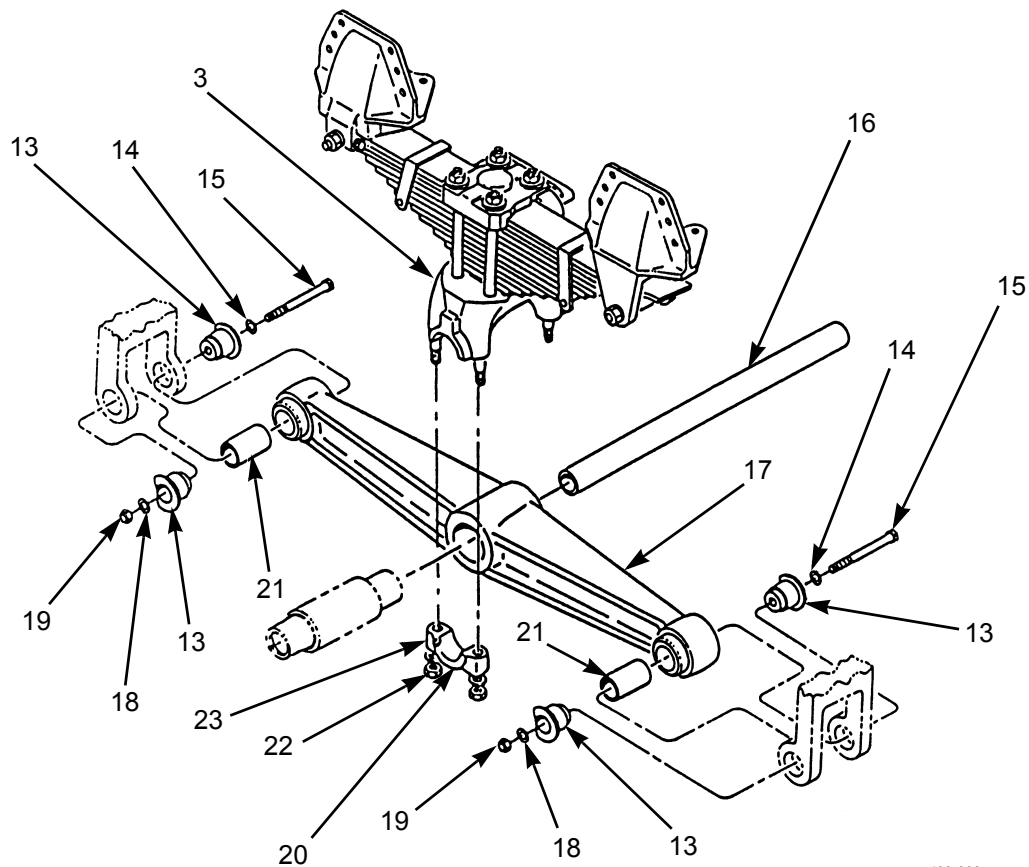

402-828

**INSTALLATION**

**NOTE**

Steps 8 and 9 are for forward-rear axle.

8. Reposition floor jack from step 5 of removal and install two spider assemblies (12), 16 washers (6), 16 screws (7), 16 washers (8), and 16 nuts (9) on both sides of forward-rear axle (2). Tighten nuts to 150-175 lb-ft (203.4-237.3 Nm) in sequence shown.
9. Install four air hoses (11) in brake chambers (10).
10. Repeat steps 8 and 9 for rear axle (5).

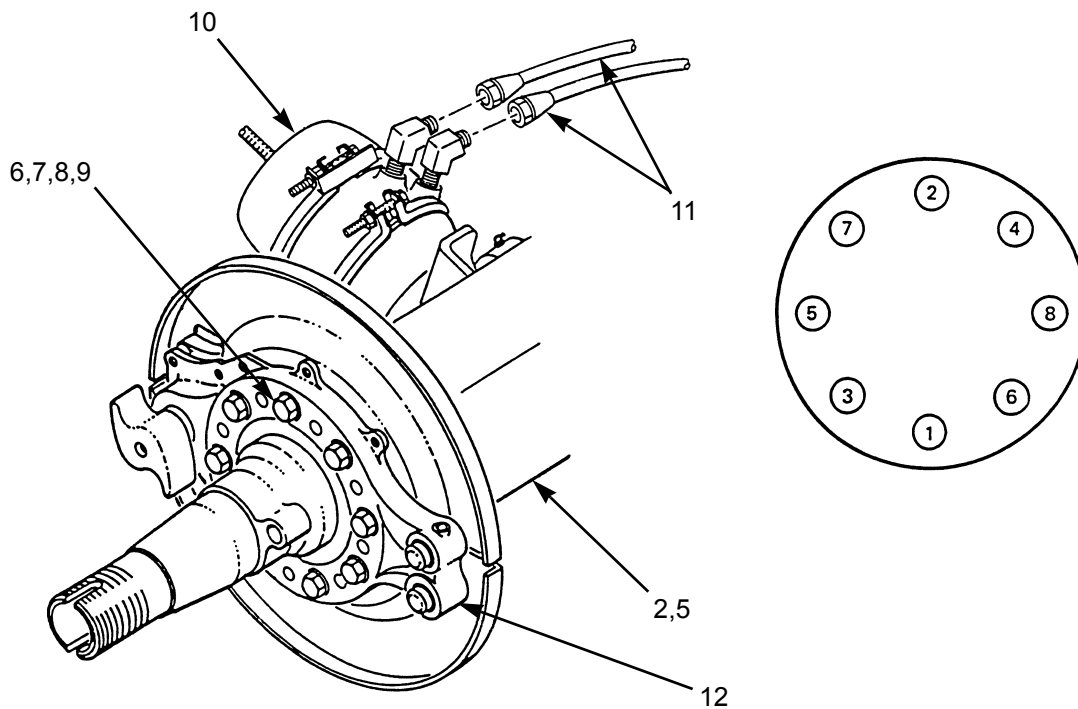

402-829

11. Install rear brakeshoe and linings (WP 0124 00).

**END OF WORK PACKAGE**





---

**EQUALIZING BEAM REPAIR**

---

0288 00

**THIS WORK PACKAGE COVERS**

Removal, Installation

---

**INITIAL SETUP****Maintenance Level**

Direct Support

**Tools and Special Tools**

Tool kit, general mechanic's (Item 102, WP 0313 00)

Press, arbor (Item 71, WP 0313 00)

**Materials/Parts**

Grease, GAA (Item 23, WP 0312 00)

Bushing, sleeve (P/N 49400)

Bushing, sleeve (P/N 45900)

**Equipment Condition**

Equalizing beam removed (WP 0287 00)

---

**REMOVAL****CAUTION**

Use press plate or support equalizing beam bore square on press bed. Failure to do so could result in bent beam, requiring replacement.

**NOTE**

Removal of bushings requires 50-ton or larger press.

1. Using suitable press, remove adapter and press adapter. Remove and discard two end bushings (1) from equalizing beam (2).
2. Using suitable press, remove adapter and press adapter. Remove and discard center bushing (3) from equalizing beam (2).

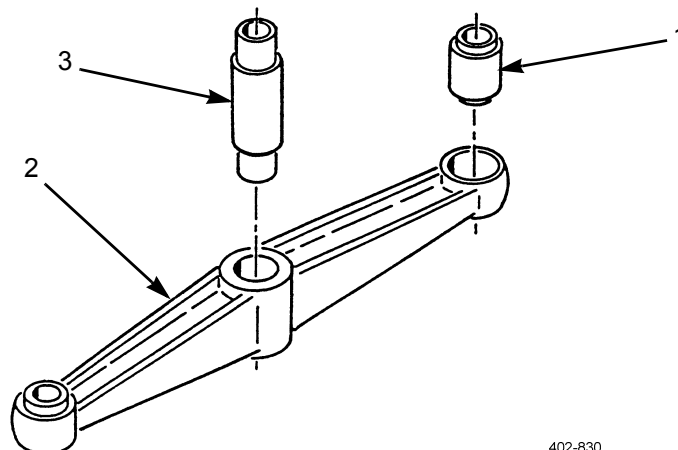

402-830

**INSTALLATION**

**CAUTION**

Use press plate or support equalizing beam bore square on press bed. Failure to do so could result in bent beam, requiring replacement.

**NOTE**

Installation of bushings requires 50-ton or larger press.

1. Coat all metal surfaces of bushings with GAA.
2. Using suitable press, install adapter and press adapter. Install new center bushing (3) in equalizing beam (2).
3. Using suitable press, install adapter clamp, plate clamp, and press adapter. Clamp installing adapter clamp to new bushing (1). With plate clamp and press adapter assembled as shown, press bushing (1) until completely installed and center in equalizing beam (3).

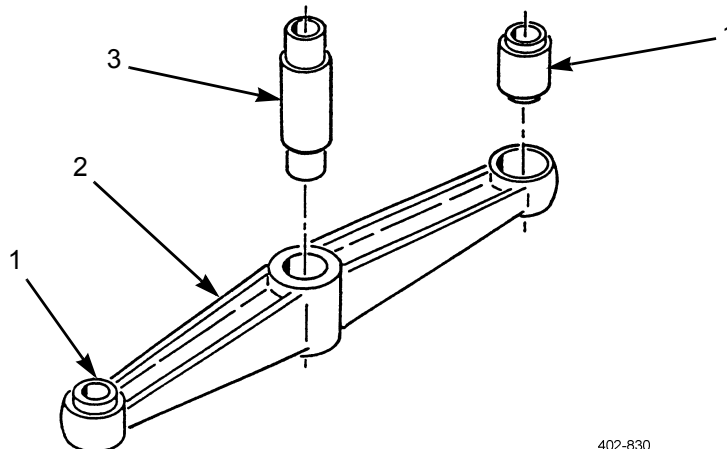

4. Repeat steps 2 and 3 for other bushing (1).

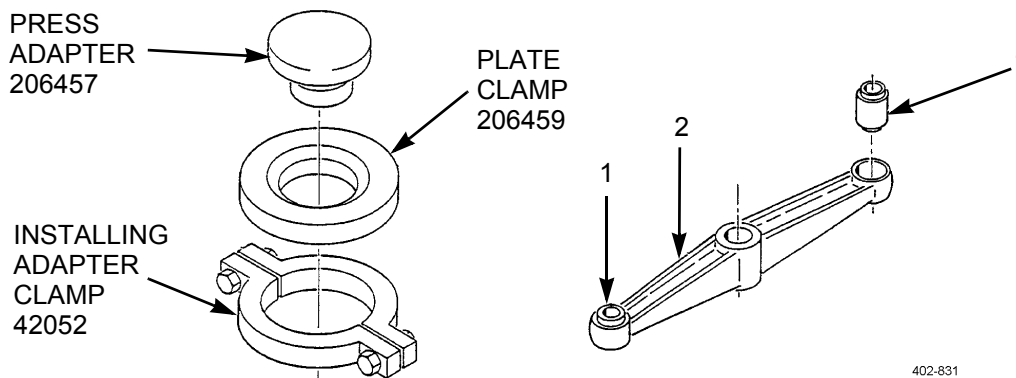

5. Install equalizing beam (WP 0287 00).

**END OF WORK PACKAGE**

**CAB BODY REPAIR****0289 00****THIS WORK PACKAGE COVERS**

General, Inspection, Rivet Replacement, Aluminum Repair

**INITIAL SETUP****Maintenance Level**

General Support

**Tools and Special Tools**

Tool kit, general mechanic's (Item 102, WP 0313 00)

Tool kit, metal worker's (Item 103, WP 0313 00)

Drill, electric, portable (Item 20, WP 0313 00)

**Tools and Special Tools - Continued**

Drill set, twist (Item 21, WP 0313 00)

Riveter, blind hand (Item 79, WP 0313 00)

**Materials/Parts**

Compound, sealing (Item 15, WP 0312 00)

Tool kit, body and fender repair (Item 48, WP 0312 00)

**References**

WP 0291 00

**GENERAL**

1. The body is constructed from aluminum alloys that have been heat treated to obtain high strength. Welding cannot be used to make body repairs. Heat generated in welding will reverse the heat treatment process and cause a great reduction in strength of material.
2. The hood is made of SMC (sheet molding compound). Cracks, splits or holes may be repaired with a glass-reinforced plastic laminate repair kit (WP 0291 00).
3. Solid 3/16-in diameter aluminum rivets are the primary method of joining body components. Rivets are inserted into a hole through two pieces of metal. A second head is formed by manual or pneumatic impacting or by squeezing the rivet. A bucking bar is used to back up the rivet to form the rivet head. When making repairs, use blind rivets of the same size or oversize diameter with the appropriate grip length.
4. Blind structural aluminum rivets of 3/16-in diameter are used in applications where there is access from only one side of the part. Blind rivets are installed using a tool that pulls on the rivet stem causing a bulbed head to form on the back side of the part. Fastening is complete when the stem breaks off. High strength is obtained in blind structural rivets by mechanically locking the remaining stem inside the rivet body.
5. Steel pull-type lock bolt fasteners in 3/16 and 1/4-in diameters are used where tension or high-shear loads exist. Lock bolts are two-piece unthreaded fasteners. One part is a high-strength, steel-headed bolt-like part with serrations on its shank. The mating part is a collar that is swaged over the serrations causing the fastener to be locked in place.
6. To facilitate repairs to the body, it is acceptable to replace lock bolts and rivets with 1/4 in AN4 series bolts. Do not replace lock bolts with rivets. Standard threaded fasteners should not be used, as these will quickly wear the aluminum structure. Bolt lengths should be chosen so that the cylindrical portion of the bolt is bearing on all members being joined. Bolts are designated as NA4-XX or AN4C-XX, where XX defines grip length. Tighten all bolts to 70-75 lb-in (8 Nm).
7. All riveted joints have adhesive foam between both components riveted together. The purpose of this tape is to ensure watertight joints and to ensure aluminum components will not wear prematurely. Tape may be either 1 in or 2 in wide, depending on the joint. Replace adhesive tape with the same size removed during disassembly. The only time adhesive foam tape is to be replaced is if a riveted joint is completely taken apart.

**INSPECTION**

1. **General.** The damaged area should be thoroughly cleaned and inspected to determine cause and extent of damage. Body parts should be inspected for holes, cracks, dents, distortion or breaks. Fasteners should be inspected for breaks, stretching, looseness, cocked heads or hole elongation. Seams, flanges, and joints should be inspected for straightness or local deformation as an indication that fasteners may have been stretched or holes elongated. It is possible for this to happen and for fasteners to still appear to be tight in their holes. In addition, make a thorough inspection of adjacent areas to determine if high loads have been transmitted from the damaged area to other areas. This can result in secondary damage in the form of distorted panels or seams, loosened or sheared fasteners, elongated fastener holes, and cracks.
2. **Classification.** After extent of damage has been determined, affected parts should be classified in one of the following categories:
  - Negligible Damage
  - Damage Repairable by Patching
  - Damage Repairable by Insertion
  - Damage Necessitating Replacement of Parts
  - a. **Negligible Damage.** Minor dents, nicks, scores, cracks, and holes in body panels which are within or are brought within reasonable limits by a simple procedure without extensive rework. These defects should be considered more serious if located in main structural members such as body side rails, a pillar or floor crossmembers rather than in body panels such as cowls or rear wheelhouses. Deep wrinkles of undetermined origin in body panels should not be classed as negligible until the source of wrinkles has been investigated and positively identified. Damage other than small dents, holes, nicks, and scratches will require repair or replacement of the part. Refer to repair of negligible damage below.
    - (1) **Negligible Cracks.** Isolated cracks less than 0.50 in (1.27 cm) long may be classified as negligible cracks provided they are stop drilled at each end to stop propagation.
    - (2) **Negligible Holes.** Isolated holes no more than 0.50 in (1.27 cm) diameter after they are made round with smooth edges are classified as negligible holes, provided the distance from the edge of the hole to the nearest line of rivets exceeds the diameter of the hole.
    - (3) **Negligible Dents and Distortion.** Small dents and distorted areas may be classified as negligible, if they can be repaired by hammering or bending without causing the material to crack. Heat may not be used for reforming.
  - b. **Damage Repairable by Patching.** Damage beyond negligible must be repaired or the section replaced. Patches can often be applied over damaged body panels. Damaged area must first be trimmed to remove sharp edges or notches that could cause start of new cracks. Patch must then be sized to overlap the area to allow for attaching rivets. Refer to *Repair by Patching* on page 0289 00-12.
  - c. **Damage Repairable by Insertion.** In certain cases, patch repairs may not be desirable because of impracticality or because a flush surface is desired. In this case, damaged area must be cut away and a partial replacement of equivalent material inserted flush with adjacent areas and backed up with a doubler. Refer to *Repair by Insertion* on page 0289 00-13.
  - d. **Damage Necessitating Replacement of Parts.** Parts are too badly damaged for repair, or replacement is easier than repair; repair for welded assemblies such as body mounts. Welded assemblies cannot be rewelded without destroying their strength and must be replaced.

**INSPECTION - CONTINUED**

3. **Rivet Failure.** Signs of rivet failure include tipped heads, looseness, and chipped or cracked paint. If heads are tipped in the same direction and rivets are loose in consecutive groups, the joint has undergone excessive load. Rivet heads that are tipped in different directions and are not in groups may be improperly installed. With chipped or cracked paint, it may be necessary to remove paint to check true condition of rivets. Rivets subjected to critical loads, but showing no distortion, should be inspected if failure is suspected. The head should be drilled off, and the shank should be carefully punched out. Failure is indicated by notched rivet shank and misaligned holes. Flush rivets showing head slippage within the dimple or countersink indicate either sheet bearing or rivet shear failure and must be removed for inspection and replacement. If failure of rivets cannot be detected by visual inspection, the joint can be checked by drilling and punching out several rivets. If rivet shanks are notched, rivets should be replaced with next larger size rivets. If rivet holes show elongation due to local failure in tearing of the sheet, next larger size rivet must be used in replacement. Any deformation of the sheet around rivet, tear outs or cracks between rivets usually indicates partially failed or damaged rivets. Complete repair of the joint will require replacement by the next larger size rivets. Use the next 1/32-in larger diameter rivet to obtain a tight joint when original hole has been enlarged. If original size rivet is installed, rivet will not be able to carry its share of shear load, and the joint will not meet its strength requirements.
4. **Lock Bolt Failure.** Lock bolts are used to withstand tension loads and high-shear loads. These fasteners are installed in holes with an interference fit. No looseness can be permitted. Lock bolts showing evidence of being stretched, broken, loose in holes or having heads that do not set flat against the surface must be replaced. Guidelines used in *Rivet Failure*, above, for detecting rivet failures also apply to lock bolts.

**RIVET REPLACEMENT****NOTE**

When removing rivets, be careful not to enlarge rivet holes. This will require use of an oversize or larger rivet for replacement.

1. **Solid Rivet Removal.**
  - a. File flat surface on manufactured head, if accessible. It is always preferable to work on manufactured head rather than a head that is bucked over. Manufactured head will always be more symmetrical around shank.
  - b. Indent center of filed surface with center punch.

**CAUTION**

Use drill slightly smaller than diameter of rivet shank to avoid making rivet hole oversized.

- c. Using drill slightly smaller than diameter of rivet shank, drill through rivet head.
  - d. Support back of rivet using sharp chisel. Cut rivet head along direction of rivet line or panel edge to prevent distortion of panel and shear off weakened rivet head.
  - e. Support panel from opposite side and drive out shank with pin punch. If rivet is unduly tight because of swelling between sheets, drill rivet shank out with undersize drill.
2. **Blind Rivet Removal.**
    - a. File small flat on rivet head.
    - b. Center punch flat. Support rivet backside, if possible.
    - c. Using small drill about the size of rivet pin, drill off tapered end of pin that forms lock.
    - d. Shear lock using pin punch to drive out pin.
    - e. Pry out remainder of locking collar.
    - f. Using drill slightly smaller than rivet shank, drill almost through rivet head.

**RIVET REPLACEMENT - CONTINUED**

- g. Pry off rivet head with pin punch.
- h. Tap out rivet shank with pin punch.

3. **Lock Bolt Removal.**

**NOTE**

If lock bolt head is inaccessible, locking collar must be removed. Remove collars by grinding or splitting collars axially with sharp chisel.

- a. Work from head side of lock bolt, if accessible. File small flat on head, if rounded.
- b. Center punch head.
- c. Using hardened drill slightly smaller than bolt head, drill through head. In cases where lock bolts are too hard to be drilled with available drills, grind head down using cutoff wheel or carbide bit in die grinder. When using grinder method, cut head down until very thin, but do not grind completely off or touch body part with grinding tool.
- d. Support head and use pin punch to pry off head or shear off with sharp chisel.

**CAUTION**

Be careful not to distort lock bolt or lock bolt hole to prevent damage to equipment.

- e. Drive lock bolt out of hole with pin punch.

4. **Rivet Hole Drilling.**

- a. Center punch all new rivet locations. Center punch mark must be large enough to prevent drill from slipping out of position and must not dent surface of material. To prevent denting, place bucking bar behind material during punching.
- b. Make sure drill is correct size (Tables 1 and 2) and point is properly ground. Number 10 drill is used to install standard 3/16-in blind rivets.

**Table 1. Drill Sizes for Solid Shank Rivets.**

Rivet Diameter (in)	Drill Size	Drill Diameter (in)
1/16	#51	0.0670
3/32	#41	0.0960
1/8	#30	0.1285
5/32	#21	0.1590
3/16	#10	0.1910
1/4	F	0.2570
5/16	P	0.3230
3/8	W	0.3860

**RIVET REPLACEMENT - CONTINUED****Table 2. Drill Sizes for Blind Rivets.**

Nominal Diameter (in)				Oversize Diameter (in)			
Rivet Diameter	Drill Size	Minimum	Maximum	Rivet Diameter	Drill Size	Minimum	Maximum
1/8	#30	0.129	0.132	1/8	#27	0.143	0.146
5/32	#20	0.160	0.164	5/32	#16	0.176	0.180
3/16	#10	0.192	0.196	3/16	#5	0.205	0.209

**NOTE**

- While drilling, hold drill at 90-degree angle to material surface. Avoid letting drill wobble, making oblong holes.
  - Avoid excessive pressure. Let drill bit do cutting.
  - Do not push drill through material.
- c. Place drill in center mark for new rivet locations or align drill with old hole when replacing old rivets with oversize rivets. When using power drill, give bit a few turns with fingers before starting motor. This will help ensure drill does not jump out of position when motor is started.
- d. Remove all burrs with metal countersink or file.

**NOTE**

Ensure no chips are trapped between sheets of metal.

- e. Clean away all drill chips.
- f. Apply sealing compound to hole and surrounding area.
5. **Hole Countersinking.**

**NOTE**

Some rivet installations in body require that rivet head be flush with material surface. In these instances, countersunk or flush head rivets are used.

- a. When using countersunk rivets, rivet holes must be countersunk with tool having 100-degree taper so rivet head will fit flush with surface.
- b. When using hand-operated countersink, hole must be tried with rivet so that recess will not be too deep or too shallow. It is best to use countersink with stop so that depth of countersink can be controlled. Typical countersinking dimensions for blind rivets are shown in Table 3. Minimum sheet thickness that can be machined for 100-degree countersink rivets is given in Table 4.
- c. Do not remove edge of hole on blind side of joint.

**RIVET REPLACEMENT - CONTINUED**

**Table 3. Countersinking Dimensions for 100-Degree Countersunk Blind Rivets.**

**Countersinking Dimensions (100°)**

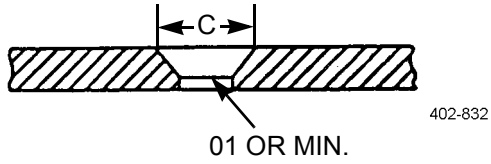

Rivet Diameter (in)	C (in)	
	Minimum	Maximum
1/8	0.222	0.228
5/32	0.283	0.289
3/16	0.350	0.356

**Table 4. Minimum Sheet Gage for 100-Degree Machine Countersink.**

Rivet Size (in)	3/32	1/8	5/32	3/16	1/4
Gage (in)	0.040	0.050	0.064	0.072	0.072

6. **Solid Rivet Installation.**

**NOTE**

When replacing rivets during repair, use same rivet size and type, if possible. If hole has been damaged, it will be necessary to drill hole oversize and use next larger rivet or oversize blind rivet.

- a. After drilling and prior to driving rivets, parts to be joined must be secured to prevent slipping during riveting. C-clamps may be used, or any of several varieties of skin fasteners may be inserted in previously drilled holes.

**CAUTION**

When riveting thin gage materials, be careful handling rivet tools to avoid damaging material.

- b. Solid rivets are available in various lengths. Correct length rivet must be chosen so bucked head is not too small or too large to form tight fit. Use Table 5 to determine proper rivet length.
- c. Three common methods of driving or setting rivets are: hand, squeeze, and pneumatic gun. All three methods use principle of upsetting or heading rivet shank against bucking bar.



RIVET REPLACEMENT - CONTINUED

Table 5. Calculating Correct Solid Rivet Length.

Rivet Diameter	Material Thickness	Add
1/4 in or less	2 in or less	1-1/2 x diameter of rivet
1/4 in or less	over 2 in	1-1/2 x diameter of rivet + 1/16 in for every 2 in of material thickness
5/16 in or more	1 in or less	1-1/2 x diameter of rivet
5/16 in or more	over 1 in	1-1/2 x diameter of rivet + 1/16 in for every 1 in of material thickness

7. **Rivet Driving Practices and Precautions.** Riveting is the major means of joining body parts. Proper procedures must be followed to maintain high-quality workmanship. Table 6 lists types of faulty rivet installations, causes, and corrective action to be taken.

Table 6. Correctly and Incorrectly Driven Rivet.

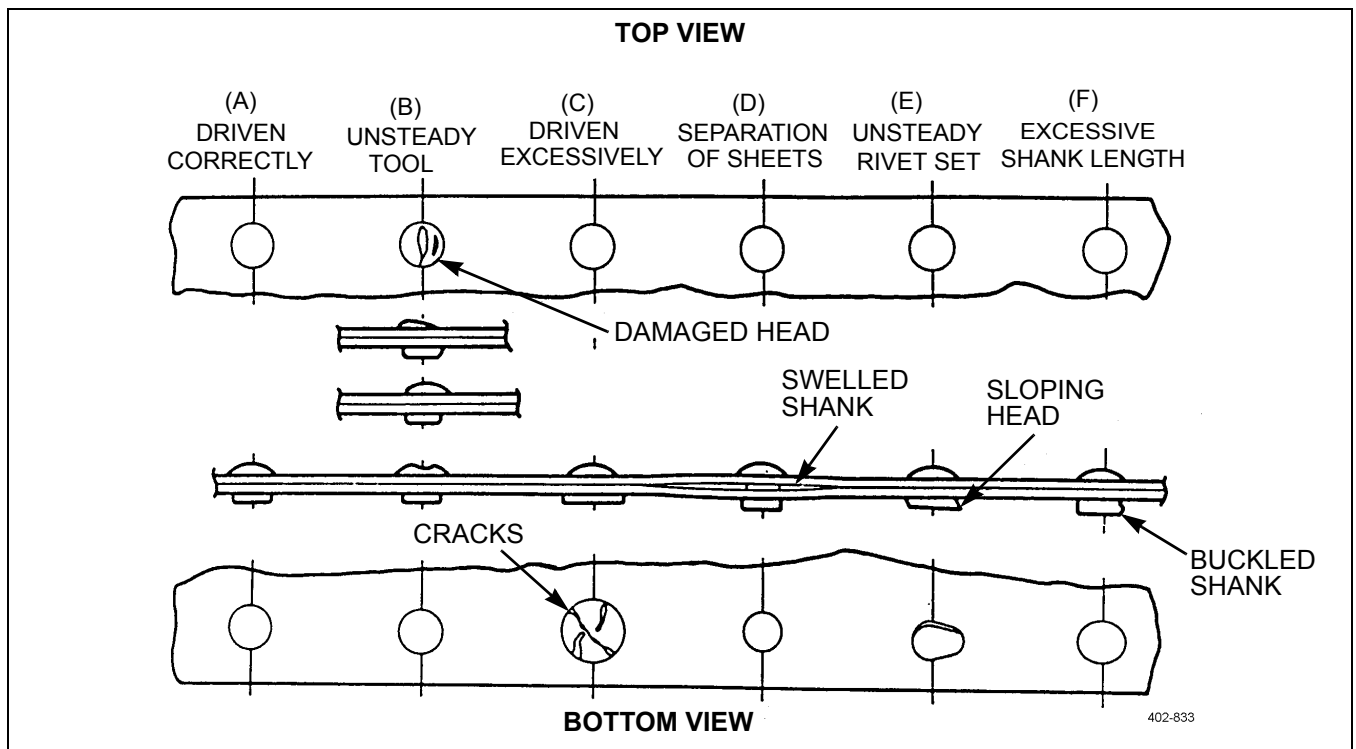

Imperfection	Cause	Remedy	Action
None	None	None	None
Cut head	Improperly held tools.	Hold riveting tools firmly against work.	Replace rivet.
Excessive flat head, resultant head cracks	Excessive driving, too much pressure on bucking bar.	Improve riveting technique.	Replace rivet.

**RIVET REPLACEMENT - CONTINUED**

**Table 6. Correctly and Incorrectly Driven Rivet - Continued.**

<b>Imperfection</b>	<b>Cause</b>	<b>Remedy</b>	<b>Action</b>
Sheet separation	Work not held firmly together and rivet shank swelled.	Fasten work firmly together to prevent slipping.	Replace rivet.
Sloping head	(a) Bucking bar not held firmly. (b) Bucking bar permitted to slide and bounce over rivet.	Hold bucking bar firmly without too much pressure.	Replace rivet.
Buckled shank	Improper rivet length and E above.	E, above, and rivet of proper length.	Replace rivet.

8. **Blind Rivet Driving Practices and Precautions.**

- a. Rivets should be inspected for proper installation. Grip length of each rivet is marked on top of rivet head to provide positive identification. Use of proper grip length will produce rivet installation where locking collar is flush with top surface of rivet head. Tolerance limit on flushness is 0.020 in (0.5 mm).
- b. For proper rivet installation, it is imperative that holes be properly prepared, tools be in good working order, and rivets be properly applied. When problems occur, source of trouble could be in any of these areas.

9. **Blind Rivet Installation.**

**CAUTION**

- Proper length rivet must be selected for each application to prevent damage to equipment. Rivet lengths are sized by range of material thickness that rivet will grip.
- Rivets can tolerate only 1/16-in variation in material thickness for each particular rivet length to prevent damage to equipment. Rivet grip lengths are called out as dash number at end of manufacturers part number.
- For double dimpled sheets, add countersunk head height to materials thickness to prevent damage to equipment.

**NOTE**

- Prior to installing blind rivets, hole must be prepared and parts must be aligned and clamped firmly in place. These steps are the same as for solid riveting operations (refer to *Rivet Hole Drilling* on page 0289 00-4).
- Proper drill sizes for standard and oversize blind rivets are given in Table 2.
- Countersinking dimensions and minimum sheet gage for countersunk blind rivets are shown in Tables 3 and 4.
- Grip lengths are determined as shown in Table 7.
- Use rivet installation tool kit, D-100-MIL-I, and puller head adapters, if required, for all blind rivets.

**RIVET REPLACEMENT - CONTINUED****Table 7. Rivet Grip Length Determination.**

Material Thickness Range (in)		Rivet Grip No.
Minimum	Maximum	
	1/16	1
	1/8	2
1/8	3/16	3
3/16	1/4	4
1/4	5/16	5
5/16	3/8	6
3/8	7/16	7
7/16	2	8
2	9/16	9
9/16	5/8	10
5/8	11/16	11
11/16	3/4	12

- a. Insert rivet stem into pulling head of rivet gun or adapter.
- b. Hold rivet gun in line with axis of rivet as accurately as possible.
- c. Apply steady, firm pressure against rivet head.
- d. Squeeze handles of manual gun. Rivet clamping action will pull sheets together, seat rivet head, and break stem flush with head of rivet.

**ALUMINUM REPAIR****CAUTION**

Repairs should not be made on body using welding or heat for forming. Heat will weaken material and cause further problems.

1. **Material.** Aluminum material used for repair should be of the same alloy and temper as original, if possible. In general, 6061-T6 should be used. Material thickness must be the same or thicker. This alloy will work well for flat repairs, but is not well suited to bending because it is hard and cracks easily when bent sharply. When bends must be made, use softer 6061-T4 aluminum alloy and increase material thickness by at least 50 percent. As a rule of thumb, 6061-T4 should be bent with minimum bend radius of one to two times material thickness, whereas 6061-T6 requires at least three times material thickness radius for bends. In all cases, bends should be closely inspected for cracks. Suitable method for avoiding bending cracks is to obtain angles that are extruded from 6061-T6 alloy, or use preformed angles for repairs.
2. **Foam Adhesive Tape.** Where it is necessary to remove parts, note that foam adhesive tape is used in joints. Use care in parts removal to avoid unnecessary distortion. Parts should be separated by peeling them apart using knife or chisel to start peeling action. Before parts are assembled, remove any remaining foam adhesive tape from joints so parts will fit together with good, even contact.

**ALUMINUM REPAIR - CONTINUED**3. **Rivet Patterns.**

- a. Rivet patterns are denoted by rivet spacing and rivet edge distance. Rivet edge distance is distance from center of rivet to nearest edge of sheet. Rivet spacing is defined from center of rivet to center of adjacent rivet.
- b. Required rivet spacing is determined by strength needed in joint. General feel for strength required can be obtained by inspecting rivet patterns in surrounding areas. Body repairs made using single rows of rivets should be performed using rivet spacing not greater than 1-1/2 in (4 cm), and not less than 5/8 in (16 mm). Use 1 in rivet spacing as general practice for repairs. Rivet spacing used in original construction may be greater due to additional strength obtained by using foam adhesive tape. Do not use rivet edge distances less than 3/8 in (5 mm).
- c. High-strength joints or large area patches may require use of double or multiple rows of rivets to obtain sufficient strength.

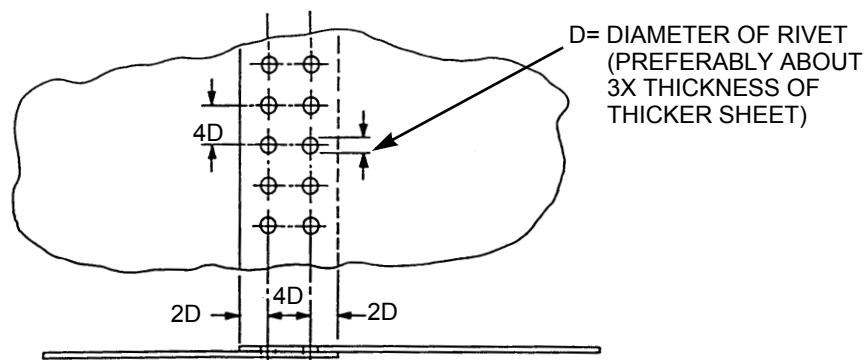
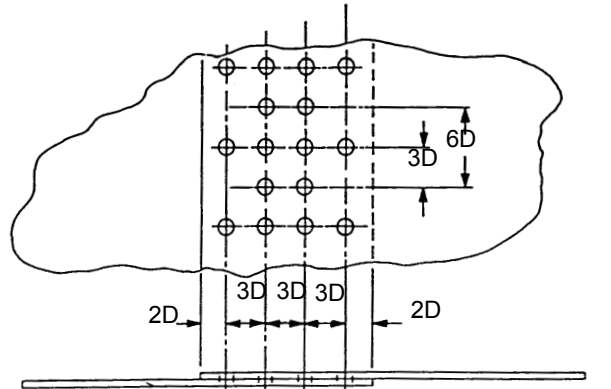
**DOUBLE ROW RIVETING PATTERN****TRIPLE OR MULTIPLE ROW RIVETING PATTERN**

402-834

**CAUTION**

Be careful not to distort original holes to prevent damage to equipment.

- d. Care must be taken to ensure rivet hole patterns are transferred accurately in the case where part with no holes is mated to one which already has rivet holes. Hole patterns may be transferred using one of the following:
  - (1) Lay new part in place and use holes in mating part as drill template. New part must be underneath mating part.
  - (2) Use removed part as drill template by clamping old and new parts together. Parts must nest flat and rivet flange must be undistorted.

**ALUMINUM REPAIR - CONTINUED**4. **Joint Design.**

- a. Loads are applied through joint to fasteners holding joint together. These loads are applied to fasteners in form of shear loads or tension loads. If load is perpendicular to axis of fasteners, fastener is loaded in shear. Fastener is loaded in tension when load is along axis of fastener, causing pull on each end of fastener.
- b. Rivets (1) are designed to be loaded in shear. Do not create new joints during repairs that cause rivets to be used in tension application. Bolts (2) should be used for tension applications or substituted for rivets in very high shear load applications.

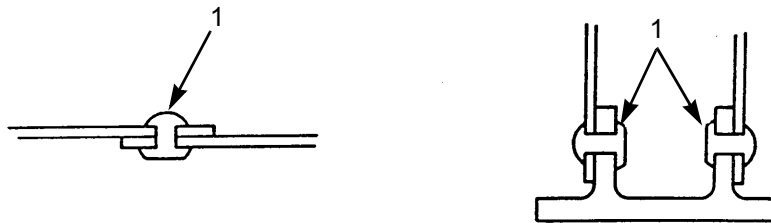
**RIVETS LOADED IN SHEAR****BOLTS REPLACING RIVETS LOADED IN TENSION**

402-835

5. **Repair Parts Preparation.**

- a. Paint repair parts or patches with epoxy primer before installation.
- b. Apply sealing compound to mating surfaces to prevent corrosion.
- c. Install part or patch as detailed in *Repair by Patching* and *Repair by Insertion* on pages 0289 00-12 and 0289 00-13.
- d. Paint repaired area with epoxy primer.
- e. Paint repaired area with polyurethane, as required.

6. **Repair of Negligible Damage.**

- a. Negligible cracks, as defined in classification above, are repaired by drilling small hole at each end of crack to stop crack propagation. This is called stop drilling. Table 8 gives proper drill sizes for stop drilling cracks.
- b. Negligible holes are repaired by rounding and smoothing edges of hole to alleviate stress risers caused by sharp notches.

**CAUTION**

Never use heat to reform parts. Heat greatly reduces part strength.

- c. Small dents and distorted areas may be repaired by bending or hammering as long as operation does not cause materials to crack or tear. Sharp bends should not be attempted.

**ALUMINUM REPAIR - CONTINUED**

**Table 8. Stop Drill Sizes for Negligible Cracks.**

Sheet Thickness (in)	Minimum Stop Drill Size No.
0-0.032	40
0.033 and thicker	30

7. **Repair by Patching.**

- a. Most body panel damage that exceeds limits of negligible damage may be repaired by patching. This procedure involves removal of damaged area (3) and application of a patch (4) to cover the area.
- b. The damaged area (3) is prepared by removal of the damage followed by rounding or smoothing of all corners and edges. This helps ensure that cracks will not spread into undamaged areas.
- c. In the case of a large crack (5), it may be desirable to stop-drill crack rather than cut out a portion of a panel (8) or structural member.
- d. Repair is completed by applying a large overlapping patch (6) over the area that was damaged. The overlap must be sufficient to allow the observance of proper rivet edge distance (7) (refer to *Rivet Patterns* on page 0289 00-10).

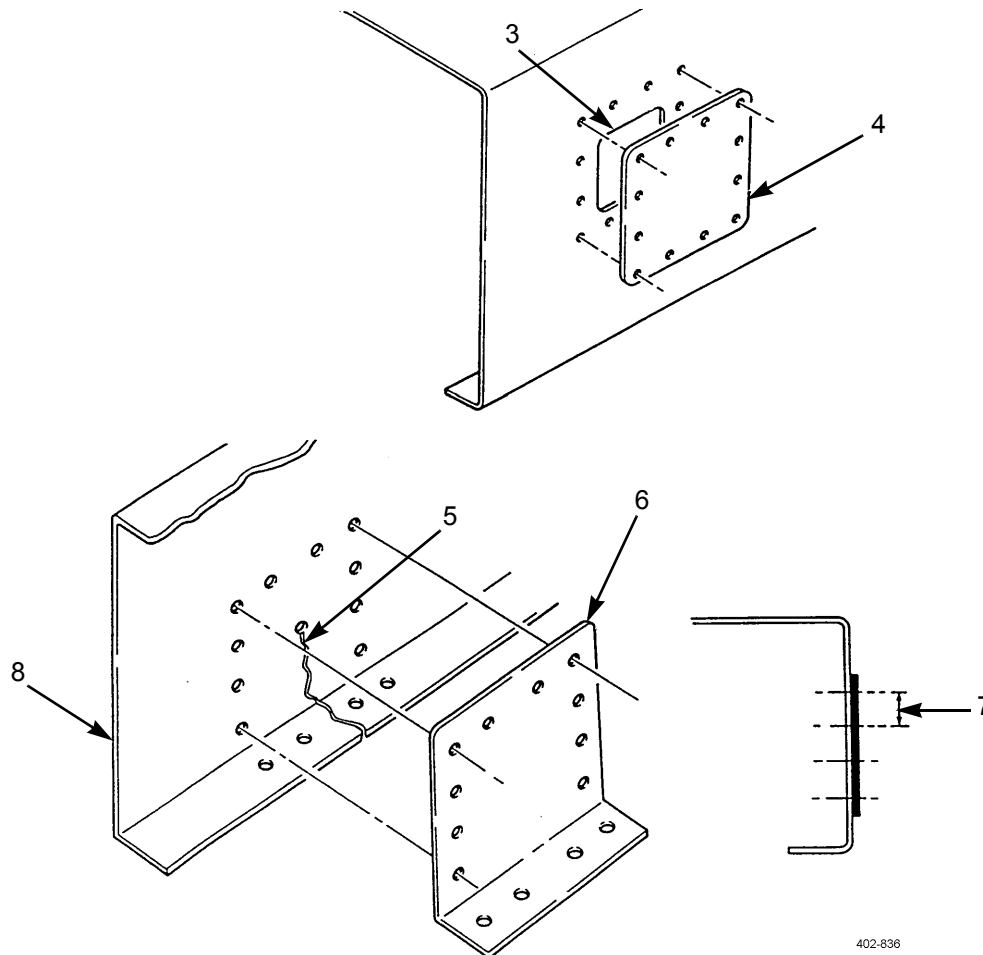

402-836

**ALUMINUM REPAIR - CONTINUED**

- e. Large areas of damage are best repaired using a patch that is attached with multiple rows of rivets (refer to *Rivet Patterns* on page 0289 00-10).

**8. Repair by Insertion.**

For damage larger or more severe in nature than crack or hole, it is often desirable to remove damaged area (9), insert piece of material (11) into removed area, and reinforce this with doubler (10). This is repair by insertion. This method of repair is typically stronger and stiffer than an added patch.

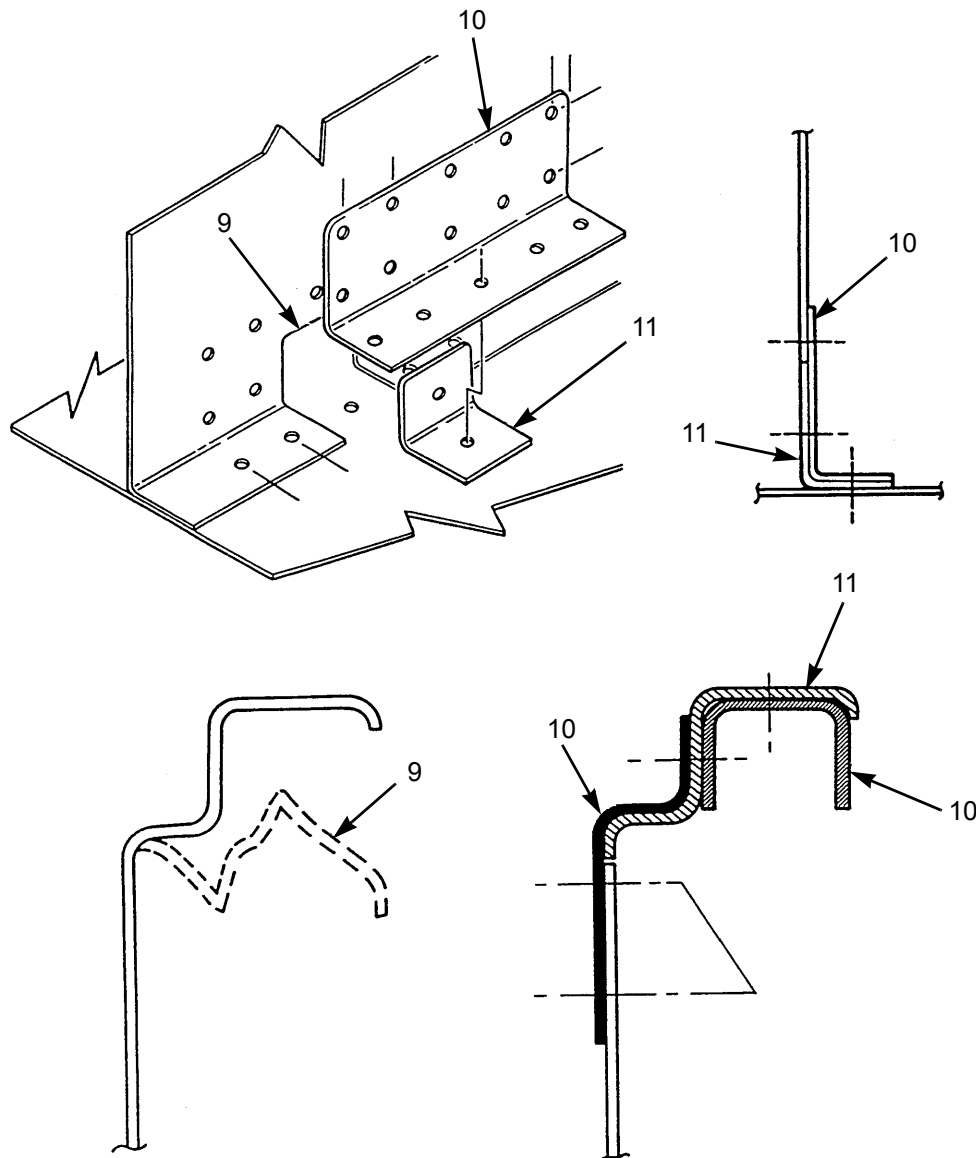

402-837

**END OF WORK PACKAGE**





**CAB REPLACEMENT****0290 00****THIS WORK PACKAGE COVERS**

Removal, Installation

**INITIAL SETUP****Maintenance Level**

General Support

**Tools and Special Tools**

Tool kit, general mechanic's (Item 102, WP 0313 00)

Sling, beam type (Item 85, WP 0313 00)

**Materials/Parts**

Nut, lock (P/N M45913/1-8CG5C) (2)

Nut, lock (P/N M45913/1-12CG5C) (2)

Nut, lock (P/N M45913/1-10CG5C) (2)

**Personnel Required**

Three

**Equipment Condition**

Cab doors removed (WP 0292 00)

AC hoses removed (WP 0305 00)

Grabhandles removed (WP 0192 00)

Muffler and exhaust stack removed (WP 0042 00)

Fender extensions removed (WP 0184 00)

Cab-to-frame ground wire removed (WP 0097 00)

Hood latches removed (WP 0182 00)

Utility lights removed (WP 0085 00)

Clearance lights removed (WP 0084 00)

Windshield wiper motor and linkage removed (WP 0200 00)

Starter relay removed (WP 0061 00)

Foot brake valve removed (WP 0146 00)

Rear window removed (WP 0295 00)

Windshield removed (WP 0294 00)

**Equipment Condition - Continued**

Windshield washer reservoir removed (WP 0204 00)

Radio mounting bracket removed (If installed)

M16 rifle mounting bracket removed (WP 0208 00)

Cup holder removed (WP 0205 00)

Transmission shift tower removed (WP 0107 00)

Floor mats removed (WP 0188 00)

Arctic heater removed (WP 0207 00)

Cab air ducts removed (WP 0296 00)

Cab liners removed (WP 0176 00)

Head liners removed (WP 0177 00)

Rotating warning light bracket removed (WP 0209 00)

Sun visors removed (WP 0194 00)

Air horn and valve removed (WP 0202 00)

Throttle and linkage removed (WP 0041 00)

Steering universal shaft disconnected at power steering gear (WP 0157 00)

Brake pedal removed (WP 0126 00)

Cab overhead wiring harness removed (WP 0240 00)

Chassis wiring harness removed (WP 0241 00)

Air tubes removed (WP 0138 00)

Anti-lock brake system (ABS) electronic control unit removed (WP 0104 00)

Cab anti-lock brake system (ABS) wiring harness removed (WP 0105 00)

Collision warning system (CWS) wiring harness removed (WP 0247 00)



**WARNING**



Use extreme caution when handling heavy parts. Provide adequate support and use assistance during procedure. Ensure that any lifting device used is in good condition and of suitable load capacity. Keep clear of heavy parts supported only by lifting device. Failure to follow this warning may result in death or injury to personnel.

**REMOVAL**

1. Remove two locknuts (1), four washers (2), and two screws (3) and swing three radiator support rods (4) out of the way. Discard locknuts.

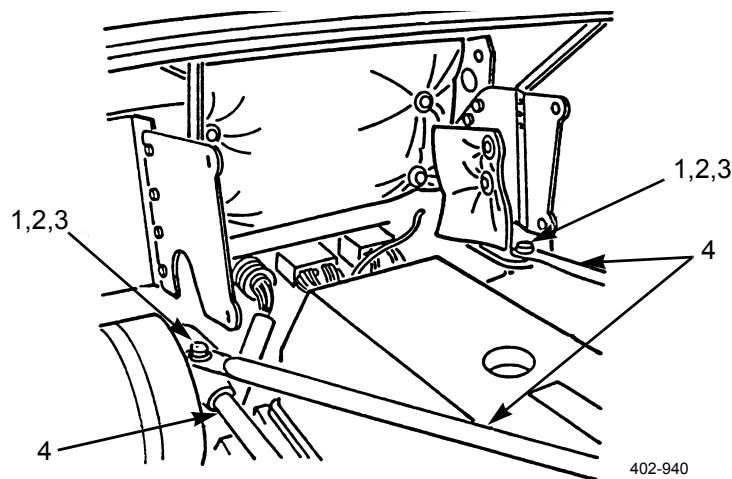

2. Attach sling and hoist to cab assembly (5). Remove all slack from chain.

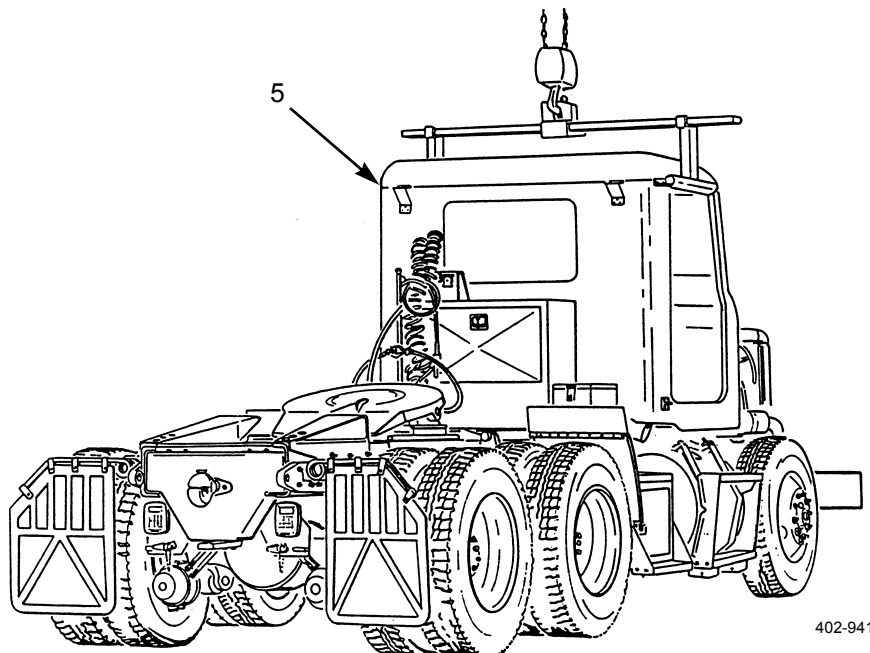

**REMOVAL - CONTINUED**

3. Remove two locknuts (9), washers (8), resilient mounts (7), and bolts (6) from front cab mounts (10). Discard locknuts.

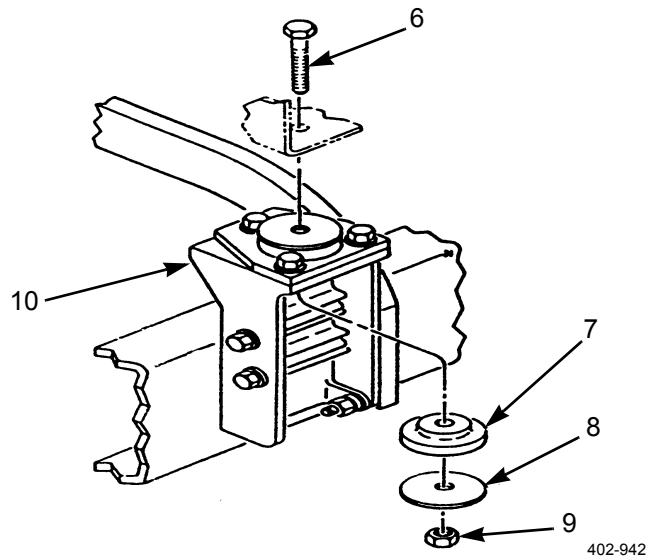

4. At right-rear of cab (5), remove locknut (11), screw (12), washer (13), and hose clamp (15). Discard locknut.
5. Disconnect two wiring harnesses (14) from underneath floor of cab (5).

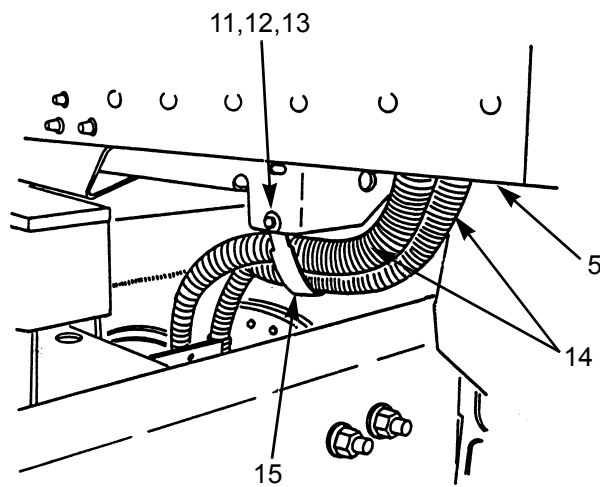

**REMOVAL - CONTINUED**

6. Remove two locknuts (18), four washers (16), two bolts (17), and resilient mounts (19) from rear cab mount (20). Discard locknuts.

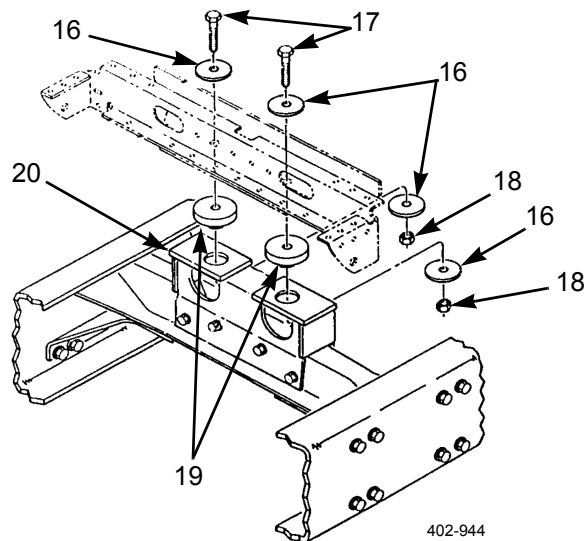
**CAUTION**

Lift cab assembly slowly and check for parts that may still be connected to cab and vehicle structure. Failure to do so may result in damage to equipment.

7. Remove cab assembly (5) from frame structure.

**INSTALLATION****WARNING**

Use extreme caution when handling heavy parts. Provide adequate support and use assistance during procedure. Ensure that any lifting device used is in good condition and of suitable load capacity. Keep clear of heavy parts supported only by lifting device. Failure to follow this warning may result in death or injury to personnel.

**INSTALLATION - CONTINUED****CAUTION**

Check underside of cab assembly as it is lowered in place. Make sure nothing is between cab and frame structure. Failure to do so may result in damage to equipment.

1. Attach sling and hoist to cab assembly (5). Position cab assembly on frame structure.
2. Install two resilient mounts (19), two bolts (17), four washers (16), and new locknuts (18) in rear cab mount (20).
3. Connect two wiring harnesses (14) to floor of cab (5). Secure hose clamp (15) with washer (13), screw (12), and new locknut (11).

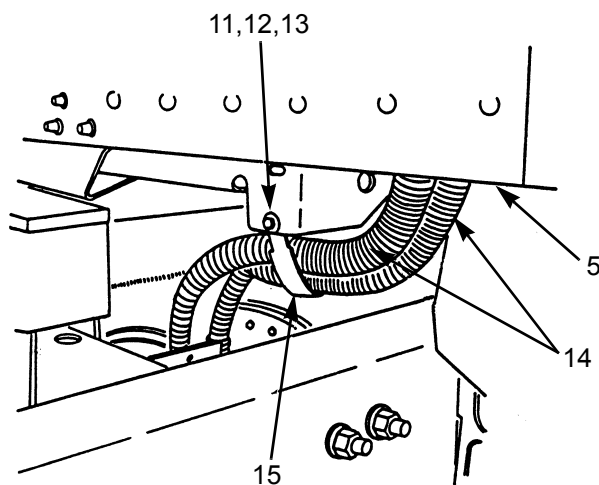

402-943

4. Install two bolts (6), resilient mounts (7), washers (8), and new locknuts (9) in front cab mounts (10).

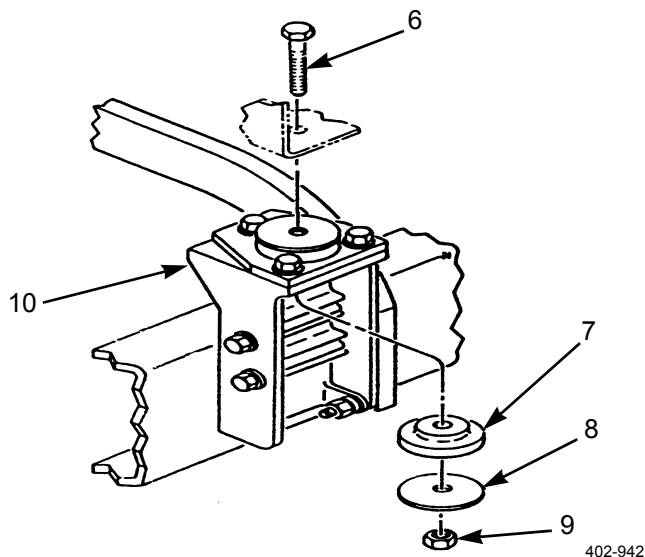

402-942

**INSTALLATION - CONTINUED**

5. Remove sling and hoist from cab assembly (5).
6. Swing three radiator support rods (4) into place and install two washers (3), screws (2), and new locknuts (1).

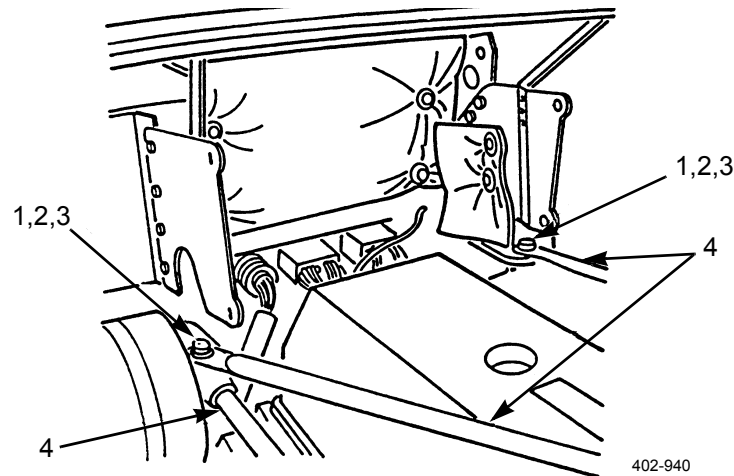

7. Install collision warning system (CWS) wiring harness (WP 0247 00).
8. Install cab anti-lock brake system (ABS) wiring harness (WP 0105 00).
9. Install anti-lock brake system (ABS) electronic control unit (WP 0104 00).
10. Install air tubes (WP 0138 00).
11. Install chassis wiring harness (WP 0241 00).
12. Install cab overhead wiring harness (WP 0240 00).
13. Install brake pedal (WP 0126 00).
14. Install steering column support bracket (WP 0273 00).
15. Install throttle and linkage (WP 0041 00).
16. Install sun visors (WP 0194 00).
17. Install cab liners (WP 0176 00).
18. Install head liners (WP 0177 00).
19. Install arctic heater (WP 0207 00).
20. Install transmission shift tower (WP 0107 00).
21. Install air horn and valve (WP 0202 00).
22. Install rotating warning light bracket (WP 0209 00).
23. Install cab air ducts (WP 0296 00).
24. Install floor mats (WP 0188 00).
25. Install cup holder (WP 0205 00).
26. Install M16 rifle mounting bracket (WP 0208 00).
27. Install radio mounting bracket (If removed).
28. Install windshield washer reservoir (WP 0204 00).

---

**CAB REPLACEMENT - CONTINUED**

---

**0290 00*****INSTALLATION - CONTINUED***

29. Install windshield (WP 0294 00).
30. Install rear window (WP 0295 00).
31. Install foot brake valve (WP 0146 00).
32. Install starter relay (WP 0061 00).
33. Install windshield wiper motor and linkage (WP 0200 00).
34. Install clearance lights (WP 0084 00).
35. Install utility lights (WP 0085 00).
36. Install hood latches (WP 0182 00).
37. Install cab-to-frame ground wire (WP 0097 00).
38. Install fender extensions (WP 0184 00).
39. Install muffler and exhaust stack (WP 0042 00).
40. Install grabhandles (WP 0192 00).
41. Install AC hoses (WP 0305 00).
42. Install cab doors (WP 0292 00).

**END OF WORK PACKAGE**





---

**HOOD SHEET MOLDED COMPOUND (SMC) REPAIR**

**0291 00**

---

**THIS WORK PACKAGE COVERS**

Inspection, Repair

---

**INITIAL SETUP**

**Maintenance Level**

Direct Support

**Tools and Special Tools - Continued**

Drill set, twist (Item 21, WP 0313 00)

**Tools and Special Tools**

Tool kit, general mechanic's (Item 102, WP 0313 00)

Drill, electric, portable (Item 20, WP 0313 00)

**Materials/Parts**

Tool kit, body and fender repair (Item 48, WP 0312 00)

Glass, reinforced plastic

---

**INSPECTION**

1. The SMC (sheet molded compound) hood consists of several parts including fenders, hood, and inner reinforcements which are bonded together with a structural adhesive and rivets. If the hood is damaged, determine which parts are affected.
2. Damage at any joint between two parts is not repairable. For example, if fender and reinforcements bonded inside the fender are damaged, replace the entire hood assembly.
3. If a joint between two parts has separated and there is no damage at the joint, the parts can be rebonded. Or, if a part is damaged and adjoining parts are not, the damaged part can be separated from the hood and new or used parts can be bonded in place. A section of a part can be replaced as long as the section does not include a joint between two parts. Fenders and headlight reinforcements are available as replacement parts or for use in section replacements. If the damage is such that parts cannot be replaced or a section replacement cannot be done, replace the entire hood assembly.
4. For repairing a small crack or hole, refer to *Crack or Small Hole Repair* below.
5. For repairing larger areas, refer to Section *Replacement (Repair of Punctures and Large Fractures)* on page 0291 00-3.
6. For replacing or rebonding parts, refer to Hood Component Rebonding on page 0291 00-7.

**REPAIR**

1. **Crack or Small Hole Repair.** A crack (fracture) or small hole through the laminate requires repair with a fiberglass reinforced patch.
  - a. Locate damage on hood. Apply hand pressure all around damaged area to check for concealed damage.

**REPAIR - CONTINUED****WARNING**

Solvents can burn easily, can give off harmful vapors, and are harmful to skin and clothing. To avoid injury or death, keep away from open fire and use in well-ventilated area. If solvent gets on skin or clothing, wash immediately with soap and water.

- b. Clean area with xylene or equivalent solvent. Inspect area closely.
- c. If sound-absorbent liner is present on underside of damaged area, remove panel(s) to provide adequate working area.
- d. If repairing crack (2), use 1/8-in diameter bit to drill hole (1) completely through uncracked laminate. Drill hole 1/8-in (3 mm) from each end of crack to prevent crack from lengthening.

**WARNING**

Wear goggles and air purifying respirator when cutting, grinding or sanding during fiberglass repairs. Ground dust and particles could cause temporary or permanent damage to eyes, and if inhaled, could cause respiratory irritation.

- e. On engine side of hood (6), use router bit on grinder or drill to grind away shallow recess. Grind recess to one-quarter depth of laminate (7) and 1/2 in (13 mm) outward from all sides of damage. Taper outside edge of ground area (5). If repairing crack (2), grind outward to drilled hole (1) at end of crack, but not beyond.
- f. Use 100-220 grit sandpaper to scuff area at least 1 in (25 mm) away from fracture on all sides (3). Scuff thoroughly to give surface to which patch can stick.

**WARNING**

Compressed air used for cleaning or drying purposes, or for clearing restrictions, should never exceed 30 psi (207 kPa). Wear protective clothing (goggles/shield, gloves, etc.) and use caution to avoid injury to personnel.

- g. Blow dust away with compressed air and wipe area with clean cloth.
- h. If necessary, align panel sections on both sides of crack (2), using weights or clamps to establish original panel profile.
- i. Using razor knife, cut section of woven fiberglass cloth (4) to overlay crack (2) about 3/4 in (19 mm).
- j. Using wooden stir stick and measuring in spoonfuls, mix equal volumes of magnolia 58 A and B epoxy resins on clean sheet of glass, metal or section of scrap laminate. Mix 15 seconds.
- k. Use stir stick to spread thin layer of mixed epoxy resins over scuffed area (3).



**REPAIR - CONTINUED****WARNING**

Solvents can burn easily, can give off harmful vapors, and are harmful to skin and clothing. To avoid injury or death, keep away from open fire and use in well-ventilated area. If solvent gets on skin or clothing, wash immediately with soap and water.

- b. Clean area with xylene or equivalent solvent. Inspect area closely.
- c. If sound-absorbent liner is present on underside of damaged area, remove panel(s) to provide adequate working area.

**NOTE**

If damage extends to joint where part is bonded to another, separate part with heat gun and putty knife before cutting.

- d. Using saber saw, cut out large, straight-sided panel (8) containing damaged area.

**NOTE**

If damage is next to, but does not include, headlight reinforcement, remove headlight reinforcement from replacement section, not from hood.

- e. From scrap hood (16) or new part, cut patch (9) from same area slightly larger than original panel (8). Trim patch to fit both size and contour of original panel.
- f. Sand patch (9) edges to allow 1/16-1/8 in (2-3 mm) gap (10) around panel (8).
- g. On engine side of hood (11), use router bit on grinder or drill to grind away shallow recess. Grind recess to one-quarter depth of laminate (12) and 1/2 in (13 mm) outward from all sides (13) of panel (8) area. Grind 1/2 in (13 mm) inward from all sides (13) on engine side of patch (9). Slightly taper outside edge of ground area around panel and inside edge of ground area on patch.
- h. Using 110-220 grit sandpaper, scuff area at least 1 in (25 mm) out from sides (14) of panel (8) area. Scuff at least 1 in (25 mm) in from sides (15) of patch (9). Scuff thoroughly to give surface to which patch can stick. Completely sand off any undercoating sprayed on these areas.
- i. Bevel edges of outer sides of both panel (8) and patch (9) to about 45 degrees.
- j. Using 220 or higher grit sandpaper, gently feather back outer painted surfaces about 1/2 in (13 mm) beyond edges of repair areas of panel (8) and patch (9).
- k. Blow dust away with compressed air and wipe area with clean cloth.

REPAIR - CONTINUED

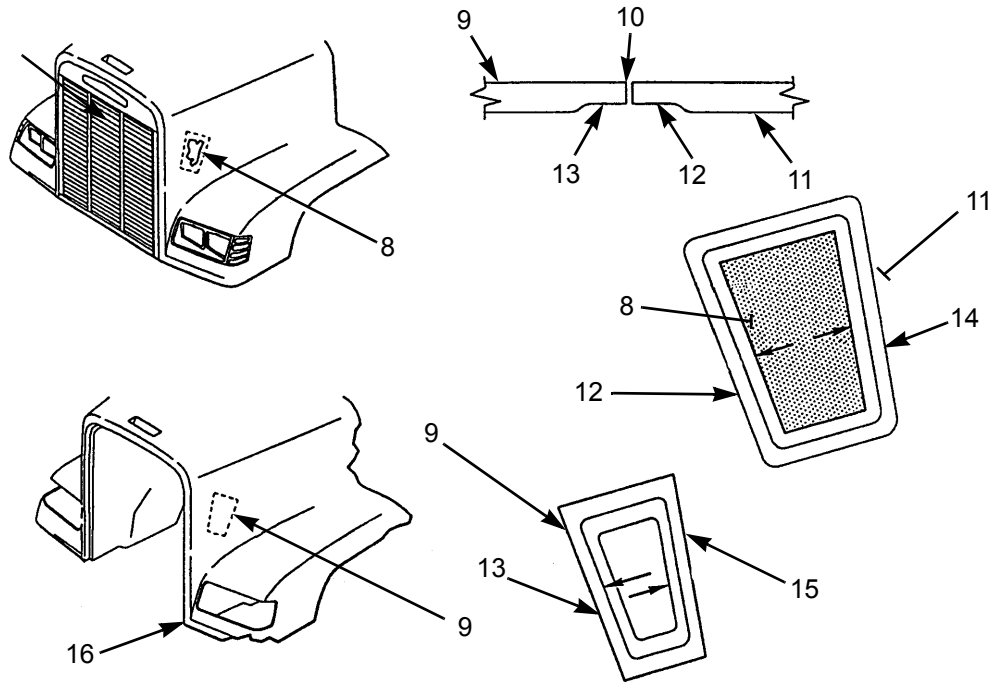

402-839

- I. If patch (9) is close enough to edge, use clamps to temporarily secure patch during repair. If patch is too far from edge to use clamps, use bond strips (17).
  - (1) Cut scrap SMC into strips (17). Make enough strips to hold patch (9) in place, about one every 6 in (15 cm). If surface of patch is contoured or curved, use many small strips. Larger strips could deform curves.
  - (2) On engine side of hood (11), use 220 grit sandpaper to scuff-sand areas on hood and patch (9) where strips (17) will be bonded.

**REPAIR - CONTINUED****NOTE**

If joint between parts was separated for repair, rebond joint. Refer to *Hood Component Rebonding* on page 0291 00-7.

- (3) Hold patch (9) in place and bond strips (17) to hood (11) and patch where scuffed. Use Lord Fuser 320/322 to bond strips.
- (4) Apply light pressure and heat from heat gun to area for 3-5 minutes.
- (5) After Lord Fuser 320/322 has hardened, use 100-220 grit sandpaper to scuff strips.
- (6) Blow dust away with compressed air and wipe area with clean cloth.

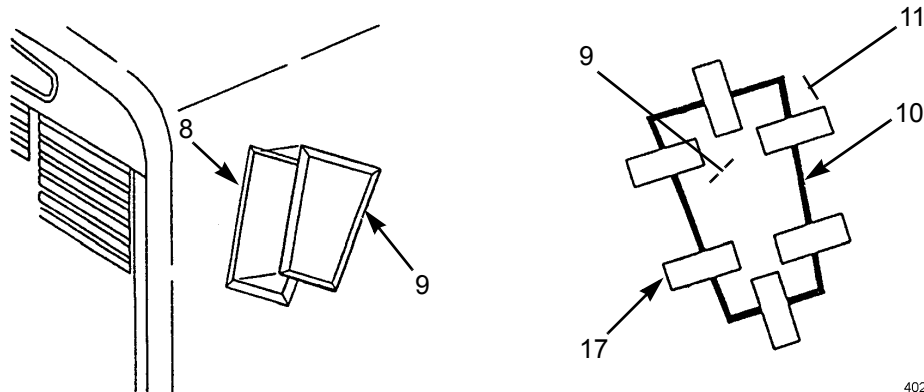

402-840

- m. Using razor knife, cut sections of woven fiberglass cloth (18) to fully cover gap (10) between hood (11) and patch (9), all around patch. Fiberglass cloth should overlay about 3/4 in (19 mm) on both sides of gap.
- n. Using wooden stir stick and measuring in spoonfuls, mix equal volumes of Magnolia 58 A and B epoxy resins on clean sheet of glass, metal or section of scrap laminate. Mix 15 seconds.
- o. Use stir stick to spread thin layer of mixed epoxy resins over scuffed area on unexposed side of repair.
- p. Lay cut sections of fiberglass cloth (18) on repair area, centered over gap (10). Using stir stick, firmly press fiberglass cloth into epoxy to completely soak fiberglass cloth.
- q. Apply another layer of epoxy resins over fiberglass cloth (18).
- r. After 2-5 minutes, epoxy will start gelling. It may take more time in cool temperatures, less in hot temperatures.

**NOTE**

For smoother surface, press piece of masking tape, wider than repair, directly over wet epoxy and smooth before epoxy hardens. Tape can be removed when epoxy sets up after 15 minutes.

- s. After body filler has hardened, sand unexposed side of repair area to smooth flat surface, if required.

**REPAIR - CONTINUED**

- t. Repair damage on outside surface of hood, and paint surface on both sides.

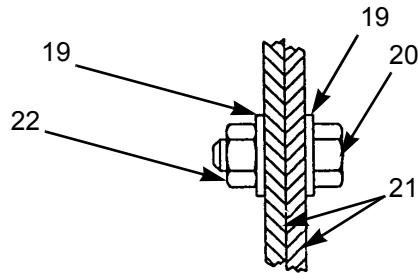
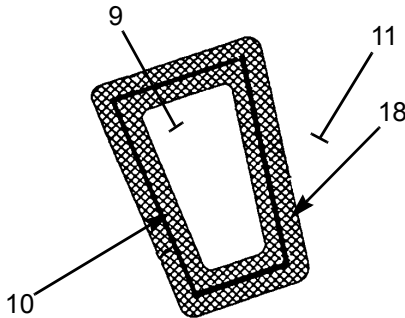

402-841

3. **Hood Component Rebonding.**

**NOTE**

If parts cannot be separated, work folded medium-grit sandpaper or section of steel hacksaw blade between two surfaces to remove old adhesive.

- a. If rebonding joint that has separated or replacing damaged part, completely separate part or parts using heat gun and putty knife. Remove as much of old adhesive as possible. Heat gun will soften adhesive and allow it to be peeled off SMC.
- b. Scuff surfaces with 100-220 grit sandpaper.
- c. Clean surfaces are to be bonded with Ashland 6036 primer or methylene chloride. Inspect area closely to be sure all old adhesive is removed.
- d. If replacing large part, such as fender, align part on hood and clamp in place. Drill hole through bonding surfaces (21) and install clamping bolt (20) in hole. Install two washers (19), one on each bonding surface. Install nut (22) on clamping bolt. There should be enough clamping bolts to hold hood in place and keep bonding surfaces together, one bolt every 12-18 in (30-45 cm). Remove part for application of adhesive.
- e. Using manufacturer's instructions, mix enough Ashland Pliogrip 6600/6622 adhesive to bond parts together, about 3/8 in (10 mm) diameter bead at bonding surface (21). Adhesive will cure in 7-10 minutes.
- f. Put adhesive in standard caulking gun and cut nozzle so 3/8 in (10 mm) diameter bead can be dispensed. If parts could not be completely separated, cut nozzle so adhesive can be injected between surfaces.
- g. Dispense 3/8 in (10 mm) diameter bead of adhesive between all bonding surfaces (21).
- h. Within 5 minutes of dispensing adhesive bead, align part on hood and clamp firmly in place. If a large part (fender, for example), install clamping bolts. Tighten clamps or clamping bolts just enough to ensure uniform amount of pressure is applied along seam. Ideally, adhesive should be compressed to form bondline 1 in (25 mm) wide and 0.030 in (0.76 mm) thick.
- i. Before adhesive cures, remove excess adhesive that squeezes out edges of bond.
- j. Bond will be secure in about 1 hour. Remove clamps.
- k. If holes were drilled for clamping bolts, repair holes using instructions in *Crack or Small Hole Repair* on page 0291 00-1.

**END OF WORK PACKAGE**





**CAB DOOR REPLACEMENT**

**0292 00**

**THIS WORK PACKAGE COVERS**

Removal, Cleaning, Inspection, Installation

**INITIAL SETUP**

**Maintenance Level**

Direct Support

**Personnel Required**

Two

**Tools and Special Tools**

Tool kit, general mechanic's (Item 102, WP 0313 00)

**References**

WP 0175 00  
WP 0293 00

**Materials/Parts**

Tape, foam (P/N 48-02454-106x27)

**Equipment Condition**

Rear view mirror removed (WP 0197 00)

**NOTE**

Procedure is the same for both doors.

**REMOVAL**

1. Remove capnut (4) and socket head screw (1).

**WARNING**

Due to size of door and angle for removal, use minimum of two personnel to remove door. Failure to do so could result in injury to personnel.

2. Remove eight screws (3) and door (2).

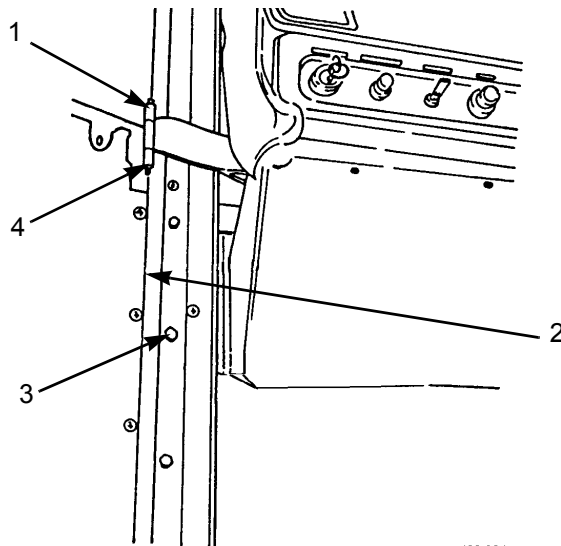

402-924

**REMOVAL - CONTINUED**

3. Remove and discard foam tape (5).

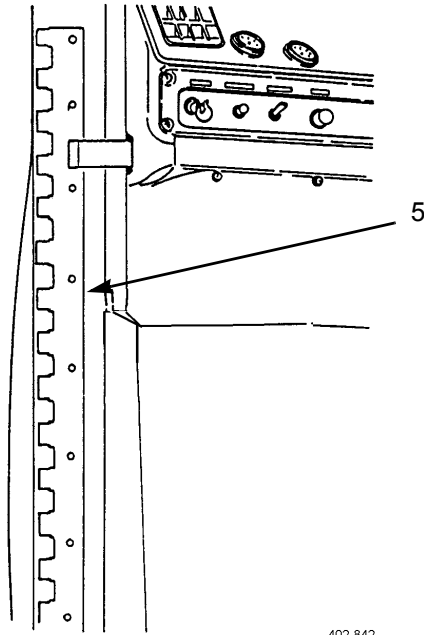

402-842

**CLEANING**

1. Use general cleaning methods to clean all parts.
2. Ensure that all traces of old foam tape have been removed.

**INSPECTION**

1. Inspect door seals and window channels for damage.
2. Inspect door locks, regulators, and release handles for proper operation. If damaged, refer to door repair (WP 0293 00).

**INSTALLATION****CAUTION**

Make sure all old foam tape has been removed. Failure to do so could cause water leakage and damage.

1. Install new foam tape (5) and, using a sharp tool, cut holes for installation of screws (3).

**WARNING**

Due to size of door and angle for installation, use minimum of two personnel to install door. Failure to do so could result in injury to personnel.

2. Position door (2) and install two screws (3) in locations indicated.

**INSTALLATION - CONTINUED**

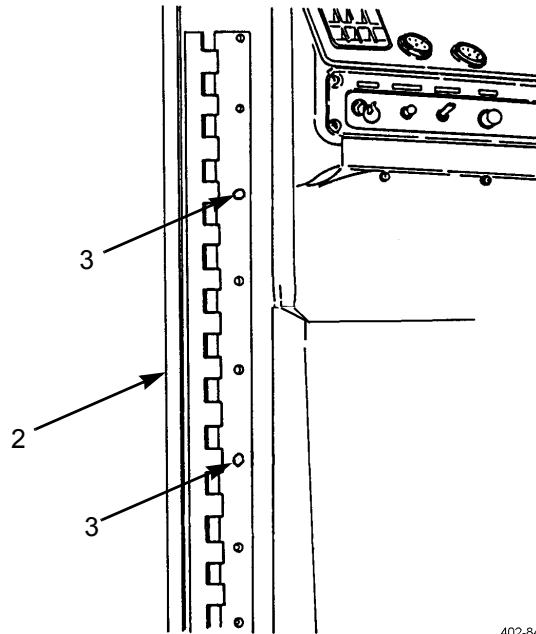

402-843

3. Perform door adjustment (WP 0175 00).
4. Install remaining six screws (3).
5. Install socket head screw (1) and capnut (4).

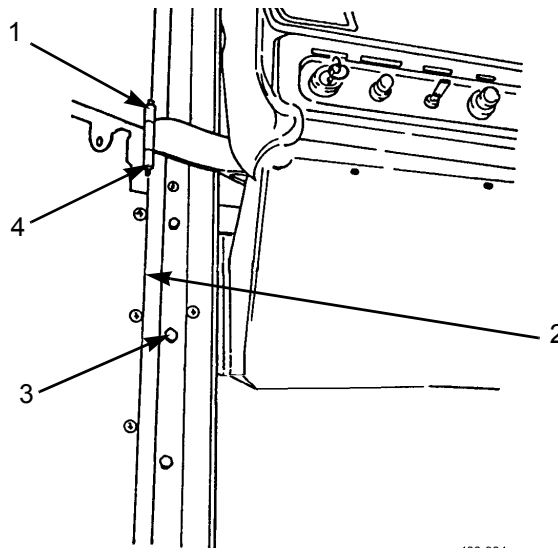

402-924

6. Install rear view mirror (WP 0197 00).

**END OF WORK PACKAGE**



---

**CAB DOOR REPAIR**0293 00

---

**THIS WORK PACKAGE COVERS**

Disassembly, Assembly

---

**INITIAL SETUP****Maintenance Level**

Direct Support

**Tools and Special Tools**

Tool kit, general mechanic's (Item 102, WP 0313 00)

Gloves, welder's (Item 29, WP 0313 00)

**Materials/Parts**

Compound, sealing (Item 15, WP 0312 00)

Grease, GAA (Item 23, WP 0312 00)

Tags, marker (Item 42, WP 0312 00)

**Equipment Condition**

Cab door removed (WP 0292 00)

---

**DISASSEMBLY**

1. If damaged, remove and discard seal (2) from door (3).
2. Lower window glass (1).

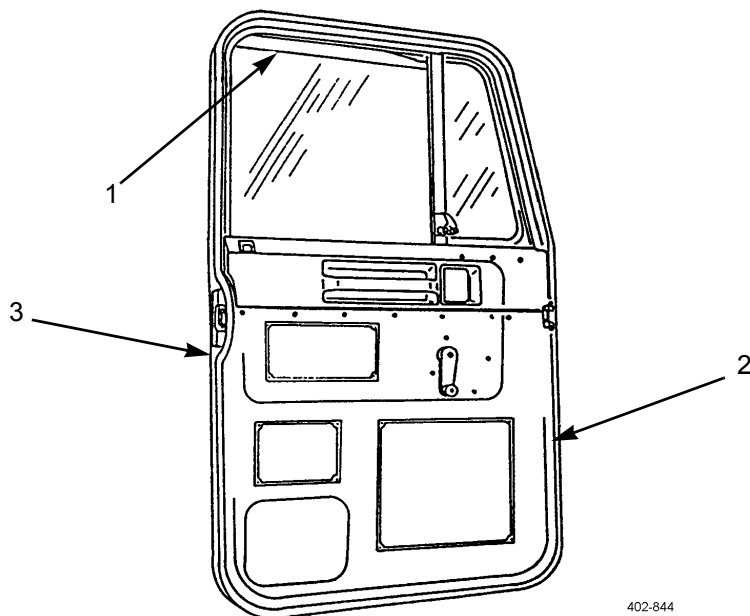

402-844

**DISASSEMBLY - CONTINUED**

**NOTE**

Tag screws, spacers, and washers during disassembly to aid in assembly.

- Remove four nuts (9), washers (8), bracket (7), three screws (4), cap screw (10), three spacers (5), and four washers (6).

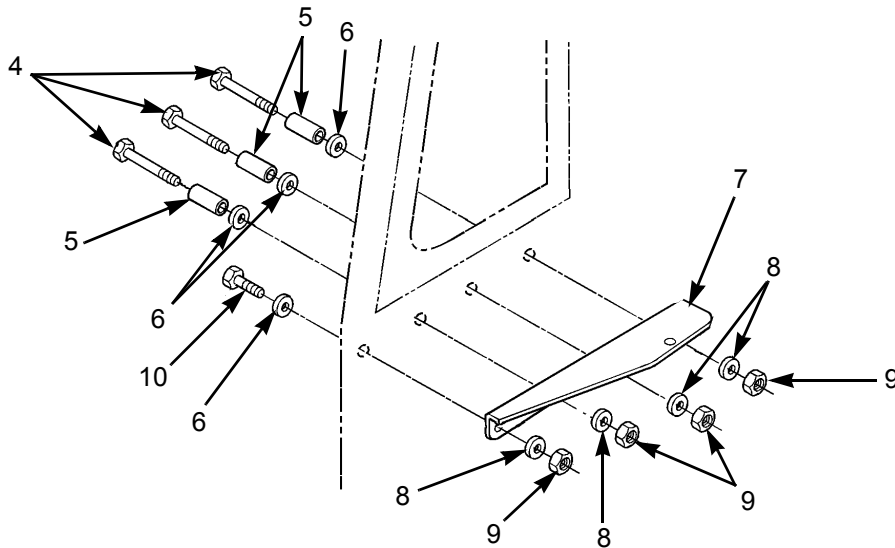

402-845

- Remove three screws (12) and washers (13) from vent window (11).

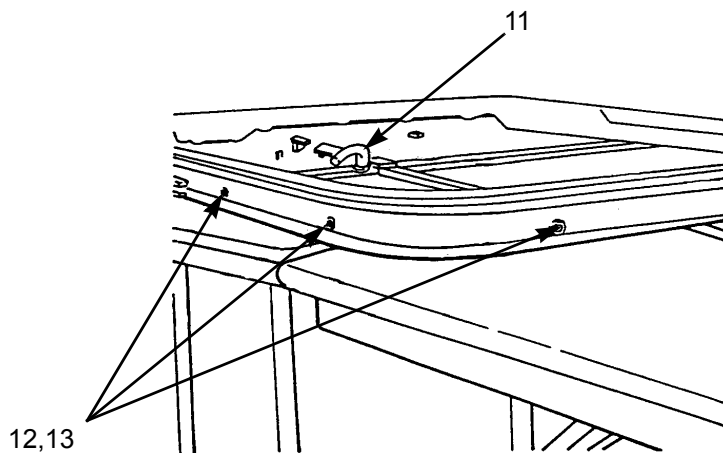

402-846

- Remove 10 in (25.4 cm) of window channel (15) from door (3) to allow removal of vent window (11).
- Remove window channel (14) from vent window (11).
- Remove vent window (11) from door (3).

DISASSEMBLY - CONTINUED

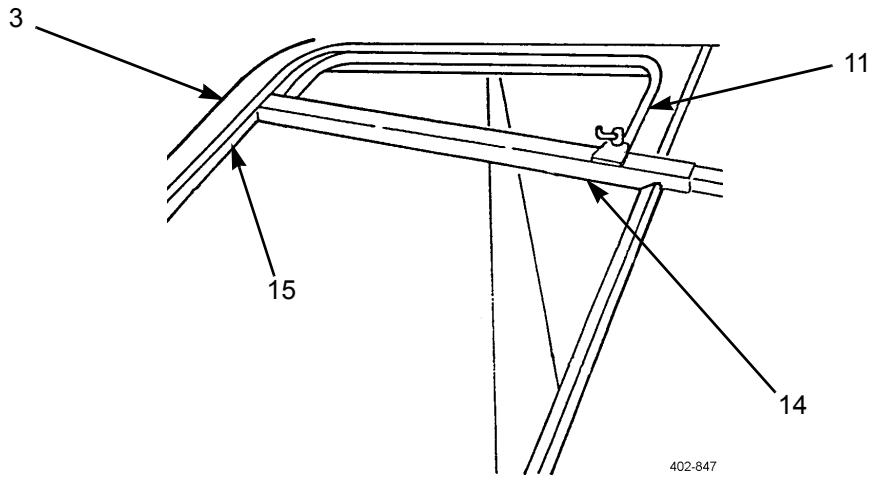

8. Remove four nuts (20), washers (19), bracket (18), four cap screws (16), and washers (17).

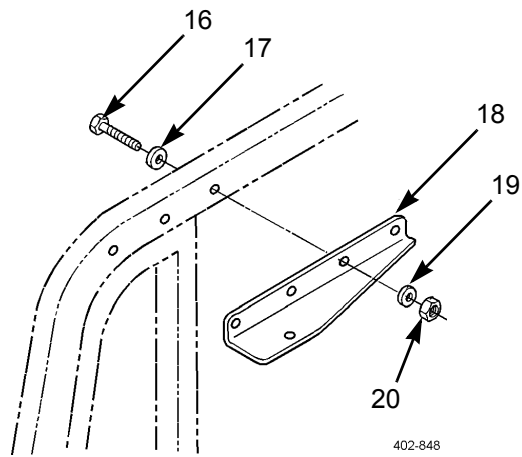

**DISASSEMBLY - CONTINUED**

9. Remove screw (22) and window crank (23).
10. Remove eight screws (21) from inside door panel (24).

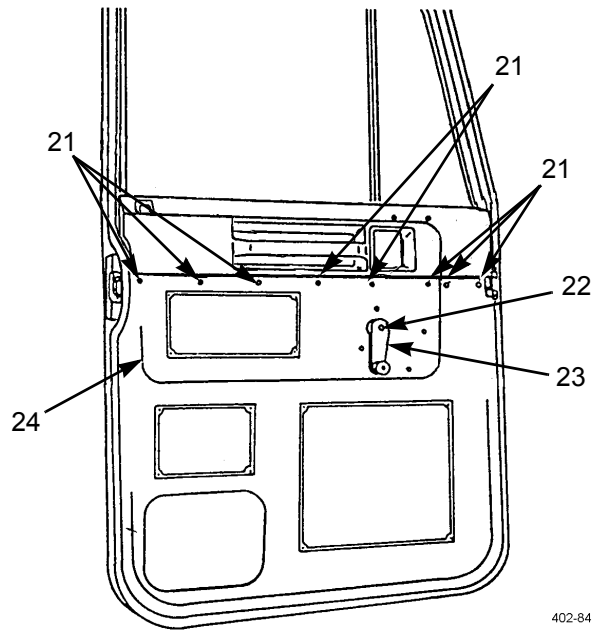

11. Remove three cap screws (25) and check arm bracket (27) from door hinge (26).

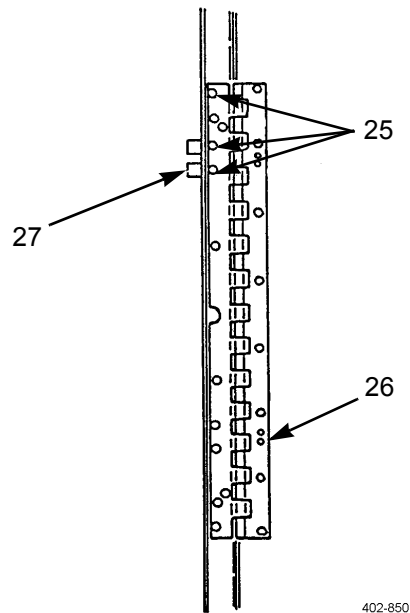



**DISASSEMBLY - CONTINUED**

12. Remove top two cap screws (28) from door latch assembly (29).

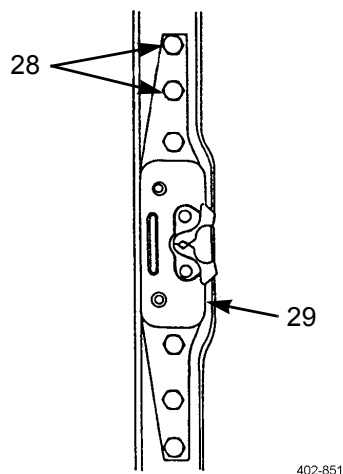

13. Remove sill (30) as follows:

**CAUTION**

Do not attempt to completely separate sill from door after completion of step b. To do so could damage interior door components.

- Grip sill door handle (32), lean sill (30) away from door (3), and pull sill upward until entire lower edge of sill unseats from inside door panel (24).
- Lean sill (30) away from door (3) and push door lock button (31) free.

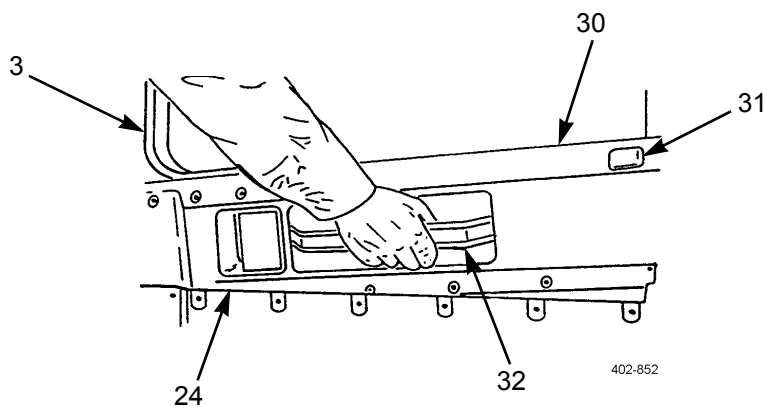

**DISASSEMBLY - CONTINUED**

- c. Disconnect release handle rod retainer (34) from release handle rod (33) and remove sill (30).

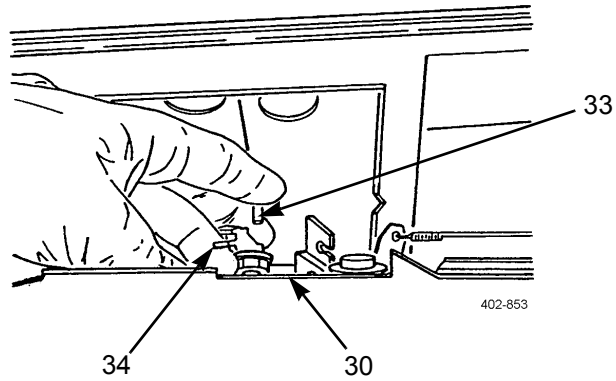

- 14. Remove four screws (35) from window regulator (36).
- 15. Disengage window regulator roller (37) from one end of window lift channel (38).
- 16. Remove window regulator (36) from inside door panel (24).

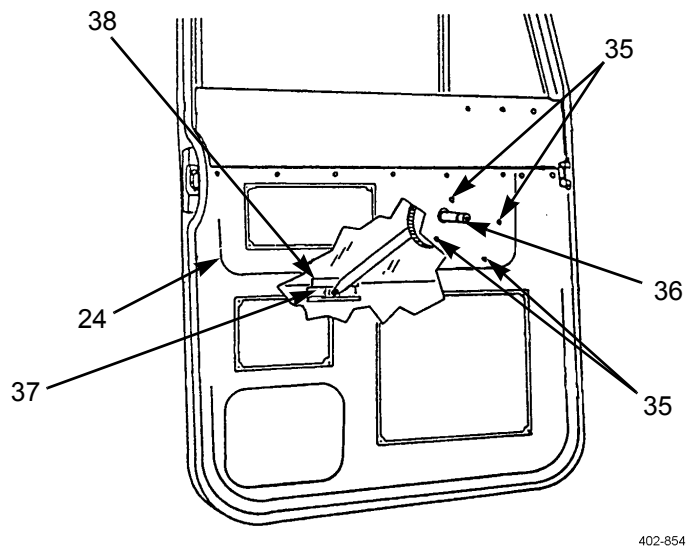

**DISASSEMBLY - CONTINUED****WARNING**

Wear protective gloves when handling glass. Failure to do so could result in injury to personnel.

17. Tilt window guide (39) toward hinge side of door (3) and carefully pull window glass (1) toward top of door. At the same time, lift window glass toward inside door panel (24) until window glass is completely removed from door.

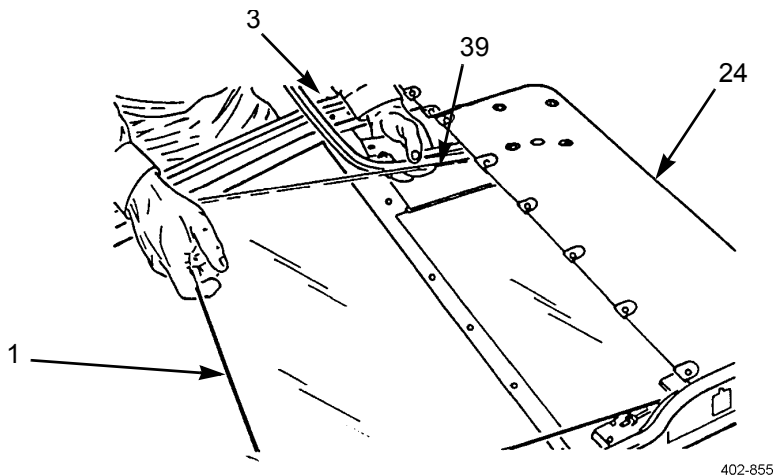

18. Remove four screws (41) and cover plate (40) from inside door panel (24).

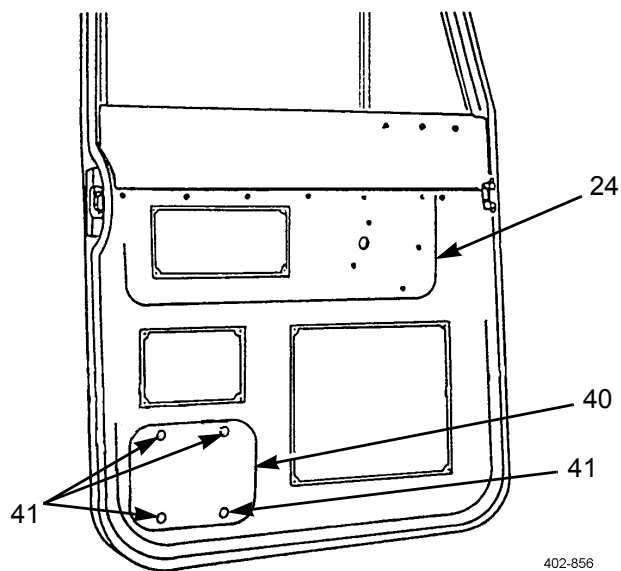

**DISASSEMBLY - CONTINUED**

19. Disconnect release handle retainer (42) and remove release handle rod (33).
20. Disconnect door lock retainer (44) and remove door lock rod (43).
21. Disconnect door latch retainer (47) and remove door latch rod (48) from exterior handle assembly (45).
22. Remove stud (49) from exterior handle assembly (45).
23. Remove fastening clip (46) and exterior handle assembly (45) from door (3).

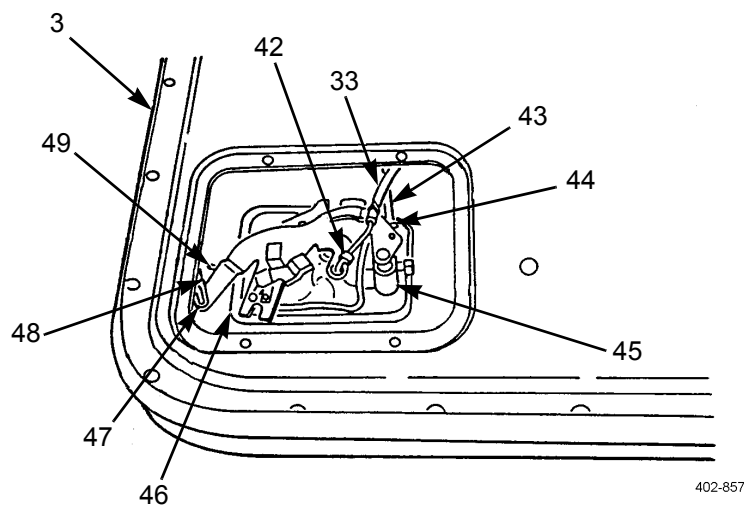

24. Remove four nuts (50), washers (51), cap screws (52), and door latch assembly (53).

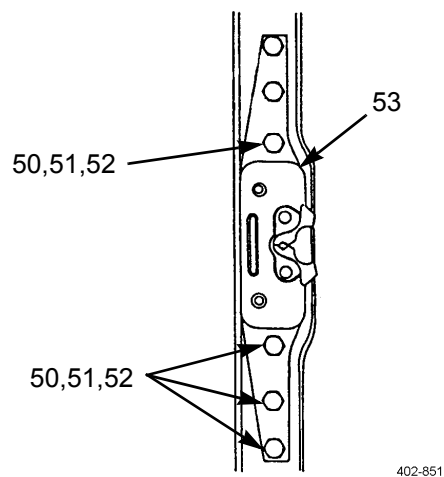

**DISASSEMBLY - CONTINUED**

25. Disconnect door latch retainer (54) and remove door latch rod (48) from door latch assembly (53).

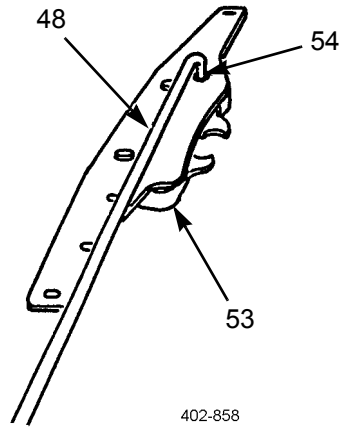

26. Remove two window channels (14 and 15).

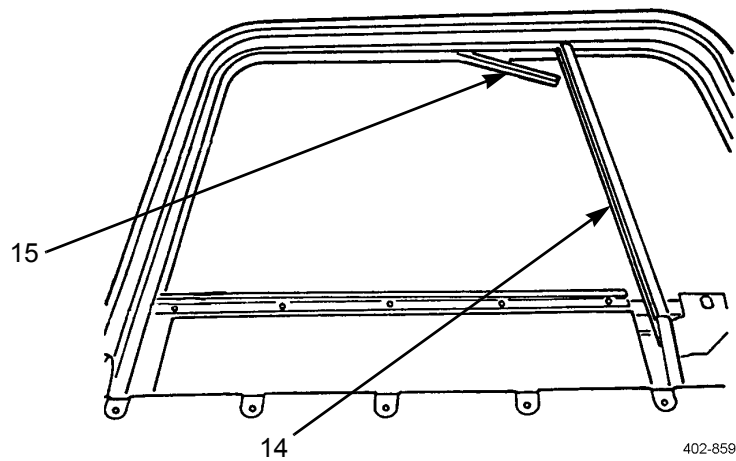

**ASSEMBLY**

1. Install two window channels (14 and 15).

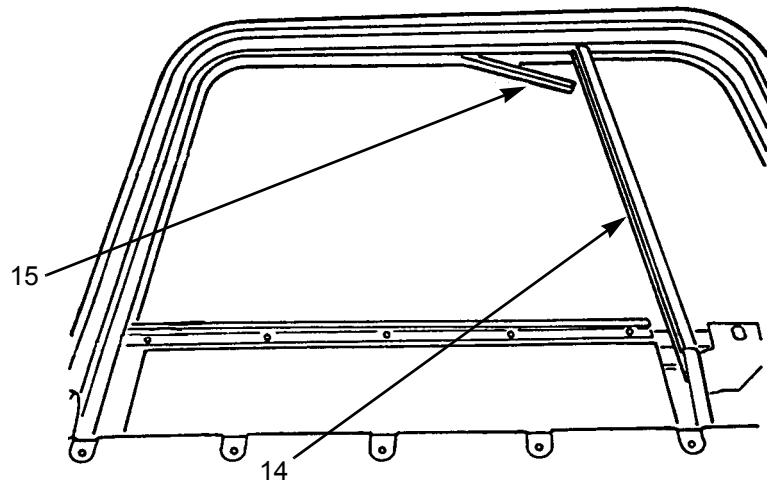

402-859

2. Install door latch rod (48) on door latch assembly (53) and connect door latch retainer (54).

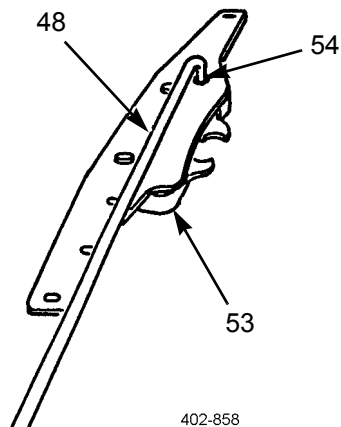

402-858

**ASSEMBLY - CONTINUED**

3. Install door latch assembly (53), four cap screws (52), washers (51), and nuts (50).

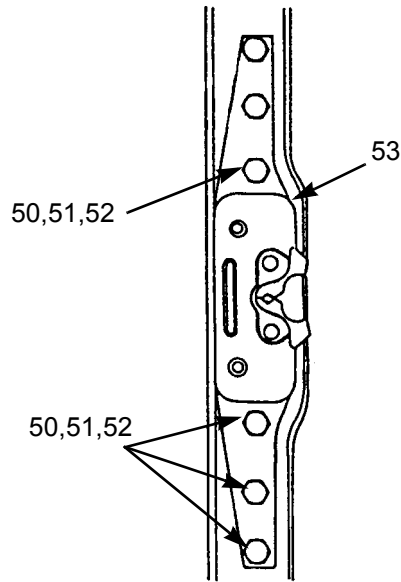

402-851

4. Lubricate all rotating points of exterior handle assembly (45) with grease.
5. Install exterior handle assembly (45) and fastening clip (46) in door (3).
6. Install stud (49) in exterior handle assembly (45).
7. Install door latch rod (48) in exterior handle assembly (45) and connect door latch retainer (47).
8. Install door lock rod (43) in exterior handle assembly (45) and connect door lock retainer (44).
9. Install release handle rod (33) in exterior handle assembly (45) and connect release handle retainer (42).

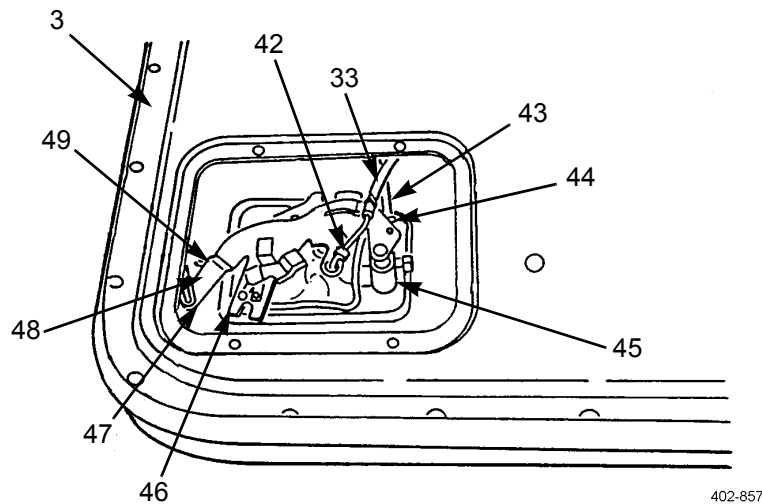

402-857

**ASSEMBLY - CONTINUED**

10. Install cover plate (40) and four screws (41) on inside door panel (24).

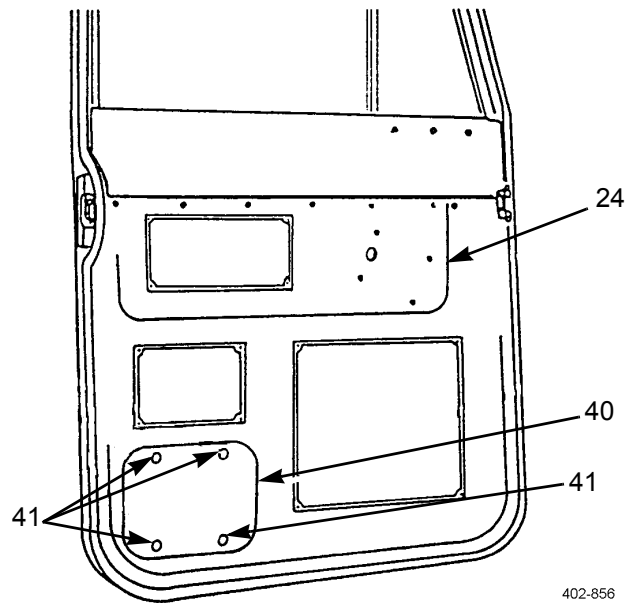

402-856

**WARNING**

Wear protective gloves when handling glass. Failure to do so could result in injury to personnel.

11. Tilt window guide (39) toward hinge side of door (3), and with window glass (1) tilted toward inside door panel (24), carefully install window glass.

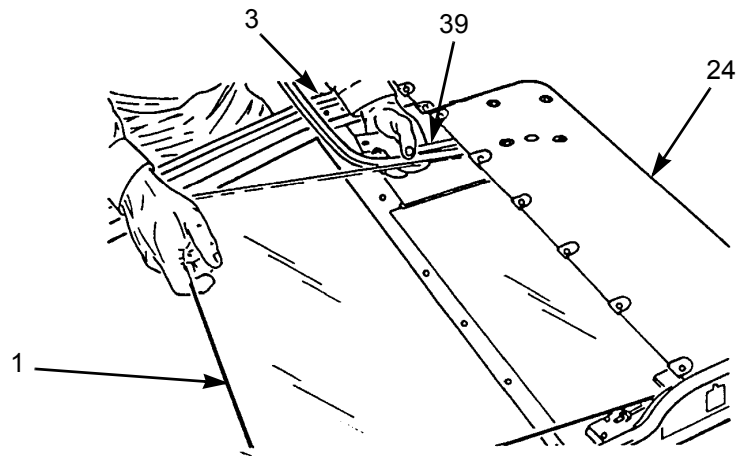

402-855



**ASSEMBLY - CONTINUED**

12. Lubricate teeth on window regulator (36) with grease.

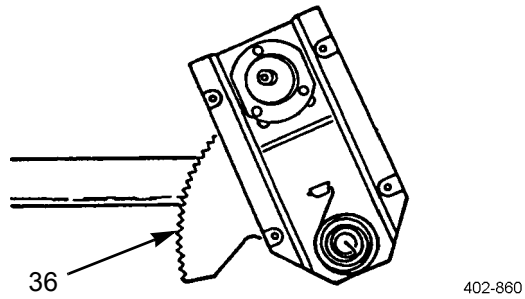

13. Install window regulator (36) in inside door panel (24).
14. Insert window regulator roller (37) in one end of window lift channel (38).
15. Install four screws (35) in window regulator (36).

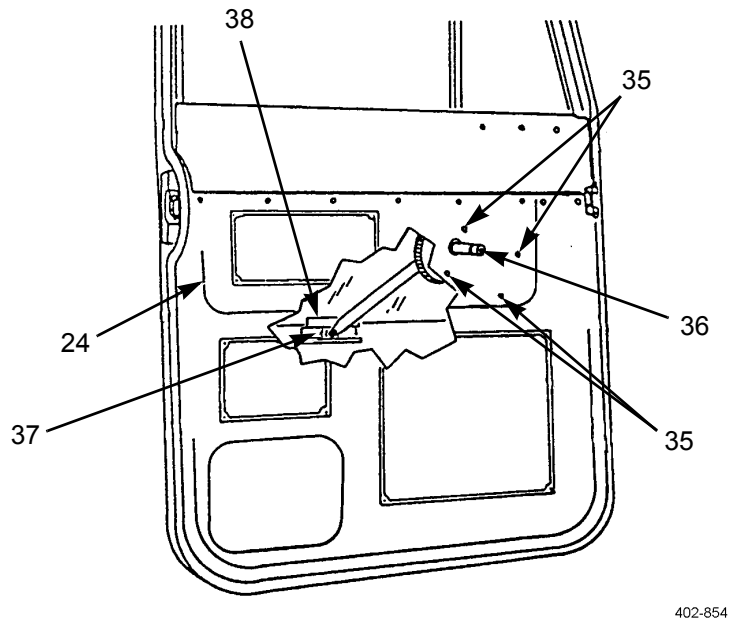

**ASSEMBLY - CONTINUED**

16. Insert sill (30) as follows:

- a. Install sill (30) just enough to allow installation of release handle rod (33) and connect release handle rod retainer (34).

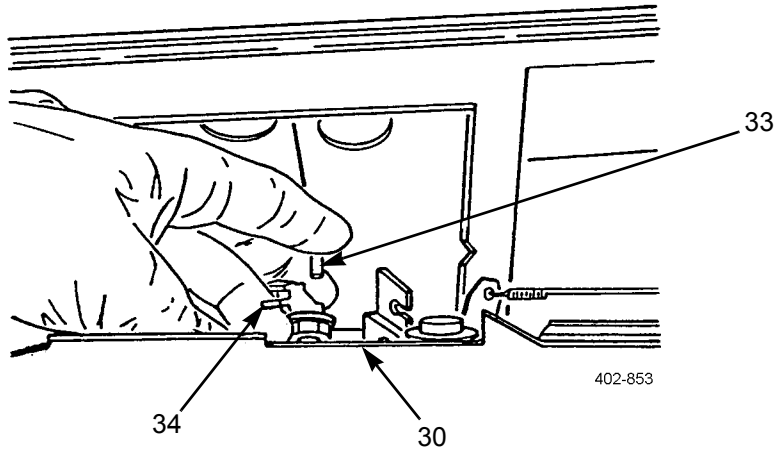

- b. Lean sill (30) away from door (3) and insert door lock button (31).
- c. Grip sill door handle (32), lean sill (30) away from door (3), and push sill downward until lower edge of sill is seated on inside door panel (24).

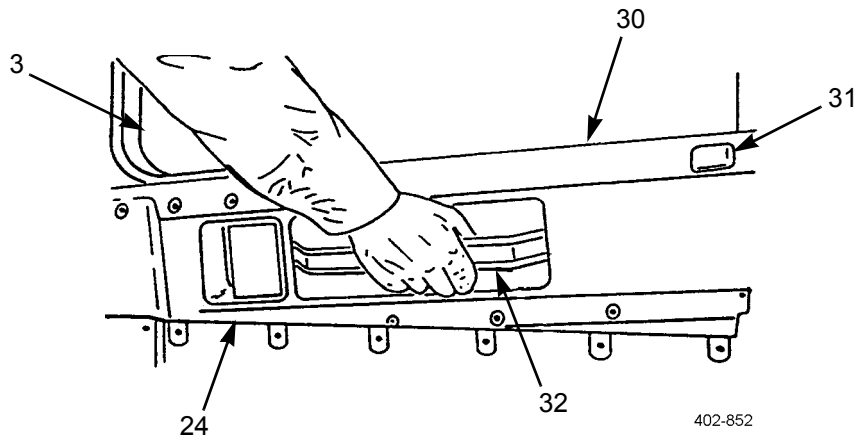

**ASSEMBLY - CONTINUED**

17. Install top two cap screws (28) in door latch assembly (29).

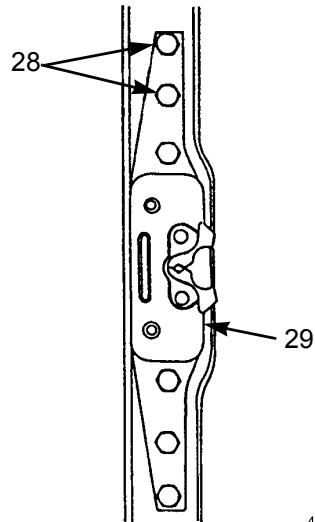

402-851

18. Install check arm bracket (27) and three cap screws (25) in door hinge (26).

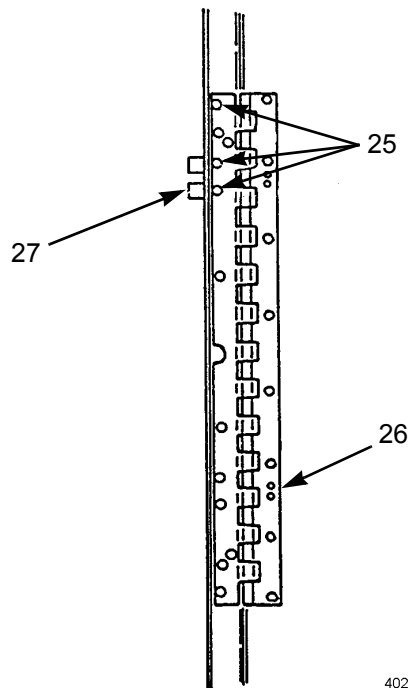

402-850

**ASSEMBLY - CONTINUED**

19. Install eight screws (21) in inside door panel (24).
20. Install window crank (23) and screw (22).

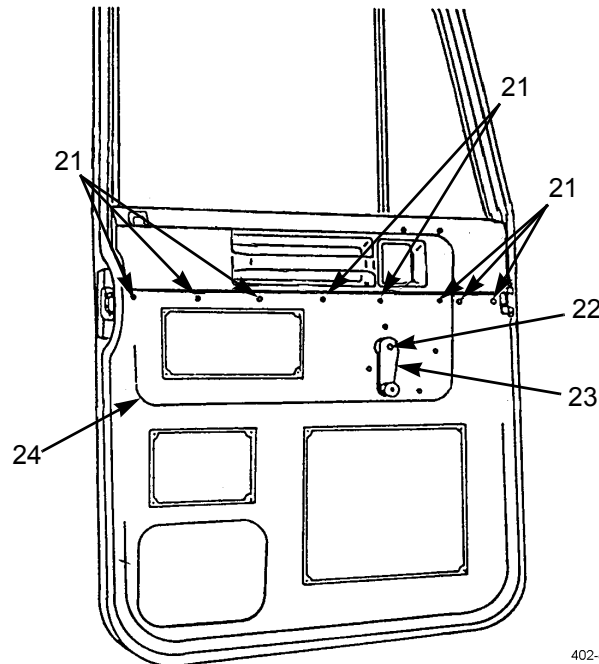

21. Install four washers (17), cap screws (16), bracket (18), four washers (19), and nuts (20).

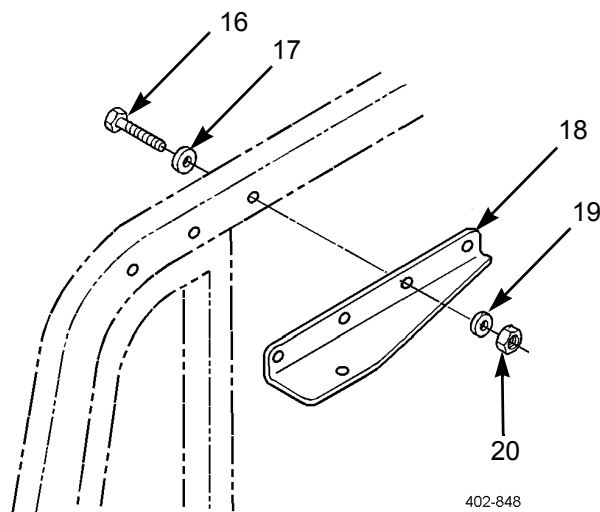

**ASSEMBLY - CONTINUED**

22. Install vent window (11) in door (3).
23. Install window channel (14) in vent window (11).
24. Install remainder of window channel (15) in door (3).

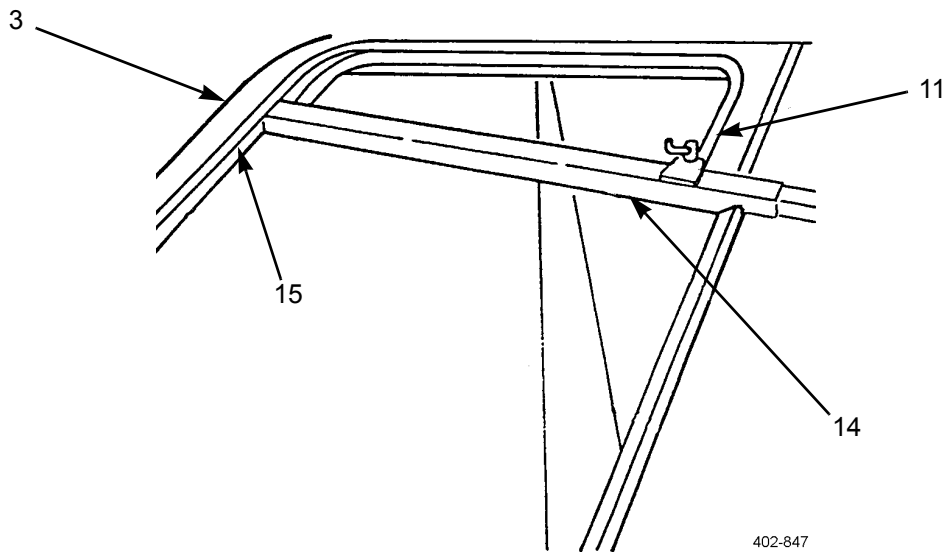

25. Install three washers (13) and screws (12) in vent window (11).

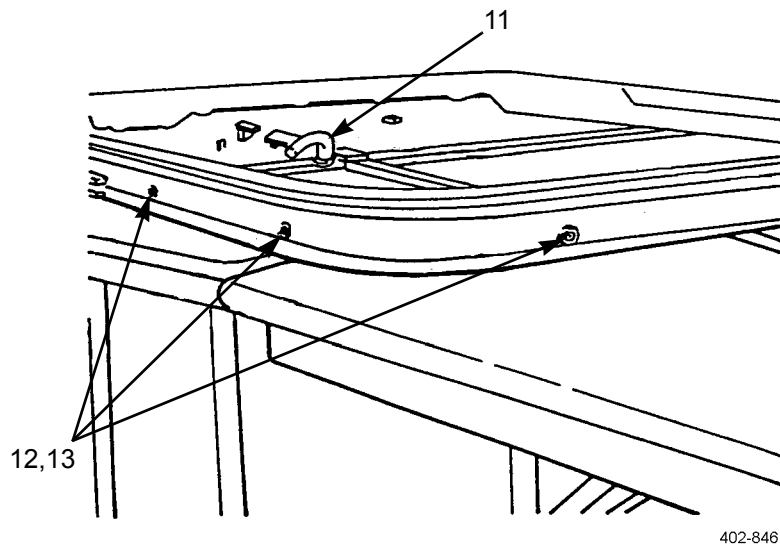

**ASSEMBLY - CONTINUED**

26. Install four washers (6), three spacers (5), cap screw (10), three screws (4), bracket (7), four washers (8), and nuts (9).

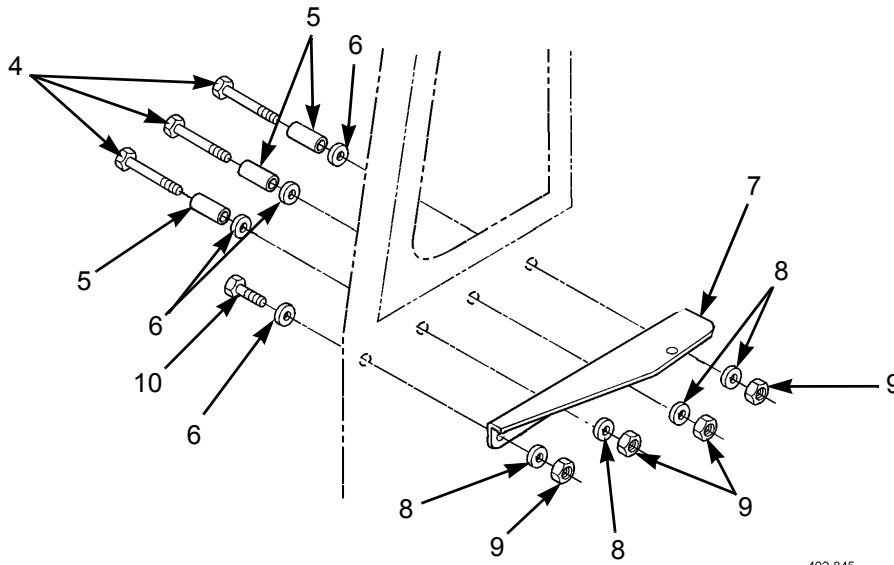

402-845

27. Raise window glass (1).

28. If removed, install new seal (2) on door (3) and apply sealing compound to each end of seal joint.

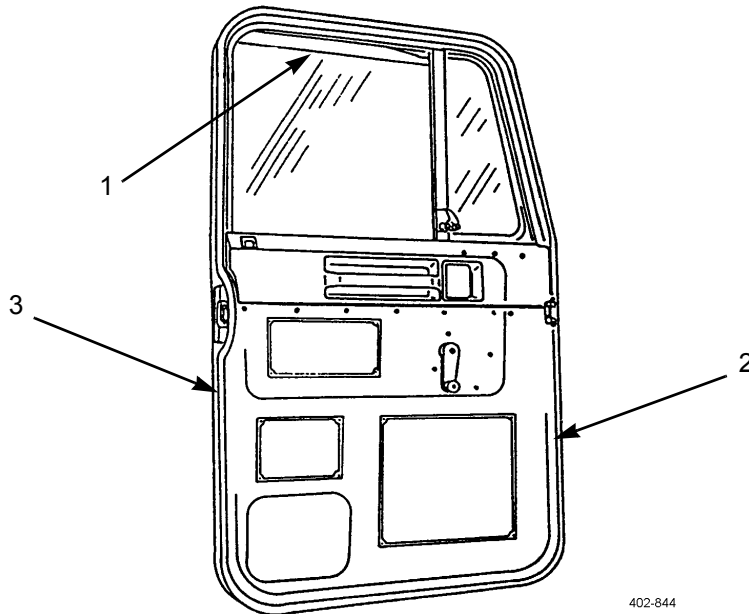

402-844

29. Install cab door (WP 0292 00).

**END OF WORK PACKAGE**

**WINDSHIELD REPLACEMENT**

**0294 00**

**THIS WORK PACKAGE COVERS**

Removal, Cleaning and Inspection, Installation

**INITIAL SETUP**

**Maintenance Level**

Direct Support

**Tools and Special Tools**

Tool kit, general mechanic's (Item 102, WP 0313 00)

Gloves, welder's (Item 29, WP 0313 00)

Wrench set, socket attachment, torx (Item 114, WP 0313 00)

**Materials/Parts**

Detergent (Item 18, WP 0312 00)

**Materials/Parts - Continued**

Mount, resilient, locking strip (P/N 18-23531-00)

Seal, nonmetallic, special (P/N 18-23530-001)

**Personnel Required**

Two

**References**

WP 0306 00

**Equipment Condition**

Windshield wiper and wiper arms removed (WP 0199 00)

**REMOVAL**

**NOTE**

Steps 1 through 3 are the same for each windshield glass.

1. If windshield glass (1) is cracked due to any cause other than being hit by a flying object, mark seal (3) at location of crack.
2. Using windshield pick, remove and discard lockstrip (2).

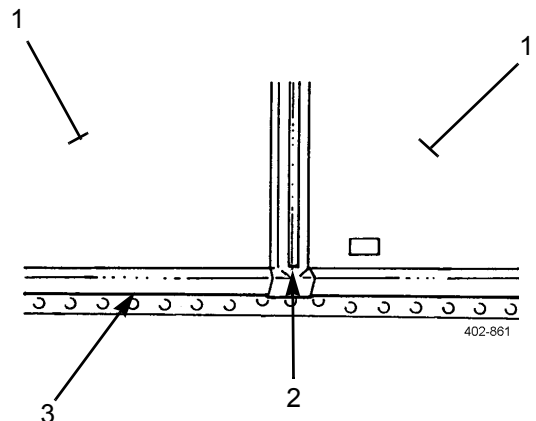

**REMOVAL - CONTINUED****WARNING**

Wear protective gloves when handling glass. Failure to do so could result in injury to personnel.

**CAUTION**

When handling windshield glass, be careful not to nick or splinter edges of glass. Chipped edges could cause cracking later.

**NOTE**

If removing windshield glass only, perform step 3. If removing seal or windshield glass and seal, perform steps 3 through 11.

3. Apply pressure to edge of windshield glass (1) from inside cab (4). Using windshield pick, lift windshield glass out of seal (3) and remove.
4. Remove seal (3) from mounting flange of cab (4).

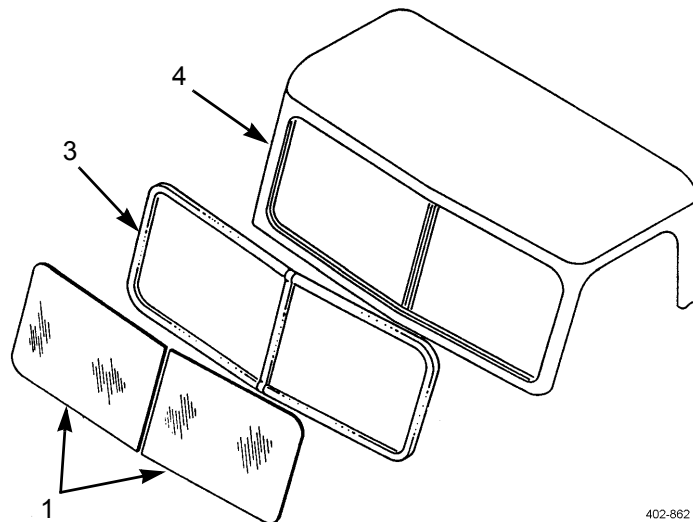

5. Remove torx screws (5), two brackets (6), and cover (7).

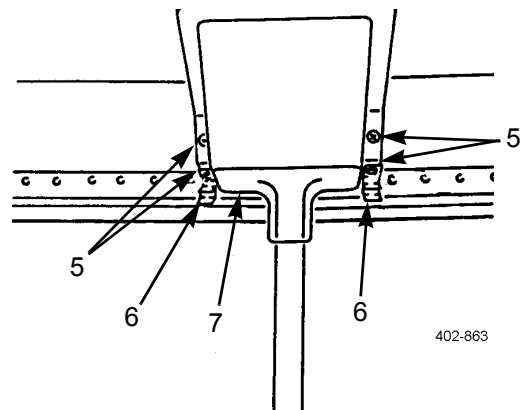



**REMOVAL - CONTINUED**

6. Remove torx screw (12) and defroster vent (11).
7. Remove two torx screws (8), washers (9), and cover (10).

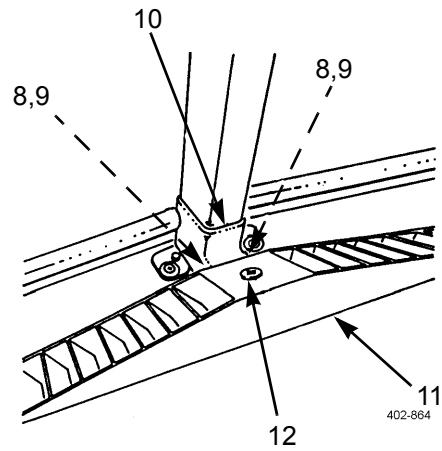

8. Remove four screws (13), washers (14), and windshield support (15).

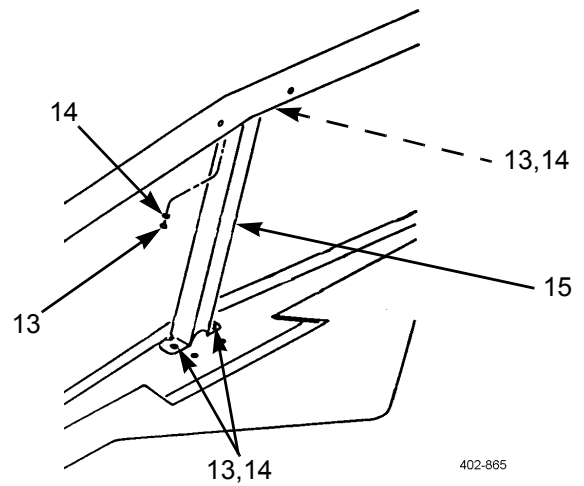

9. Cut away portion of seal (3) molded around cab flange (16).

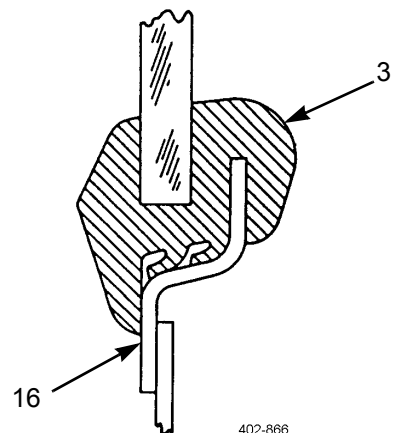

**WINDSHIELD REPLACEMENT - CONTINUED**

0294 00

**REMOVAL - CONTINUED**

10. Remove each windshield glass (1) and seal (3) as an assembly from cab (4).
11. Remove seal (3) from each windshield glass (1).

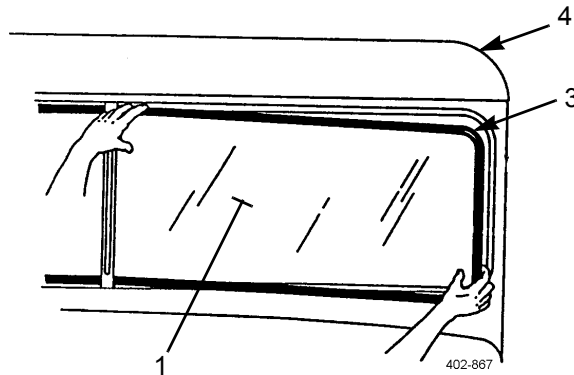
**CLEANING AND INSPECTION**

1. Use general cleaning methods to clean all parts (WP 0306 00).
2. If windshield is removed due to criteria outlined in Removal step 1, inspect channel of seal (where marked) for foreign objects, and inspect mounting flange of cab for irregularities.
3. Inspect all parts for wear or damage.

**INSTALLATION****WARNING**

Wear protective gloves when handling glass. Failure to do so could result in injury to personnel.

**CAUTION**

- When handling windshield glass, be careful not to nick or splinter edges of glass. Chipped edges could cause cracking later.
- Do not use windshield sealant. Windshield sealant compounds are not needed and, if applied unevenly, can cause leaks resulting in water damage.

**NOTE**

- Manufacturer's ID number must be at lower center corner of windshield glass when installed.
- If installing windshield glass only, perform steps 1 through 7. If installing seal or windshield glass and seal, perform steps 8 through 23.
- Steps 1 through 7 are the same for each windshield glass.

**INSTALLATION - CONTINUED**

1. Lubricate window channel of seal (3) with soap and water solution.
2. Slide windshield glass (1) into window channel of seal (3) as far as it will go without forcing.
3. Stretch seal (3) around outside of windshield glass (1) and install windshield glass in window channel of seal.
4. Using windshield pick, alternate between top and bottom of mounting flanges of cab (4) to work seal (3) over mounting flange.
5. With assistant pushing lightly on outside of windshield glass (1), finish working seal (3) over mounting flange of cab (4).
6. Finish sealing windshield glass (1) and seal (3) by gently pushing all the way around outside edge.
7. Install new lockstrip (2).

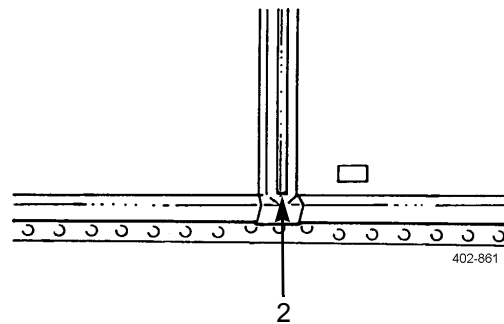
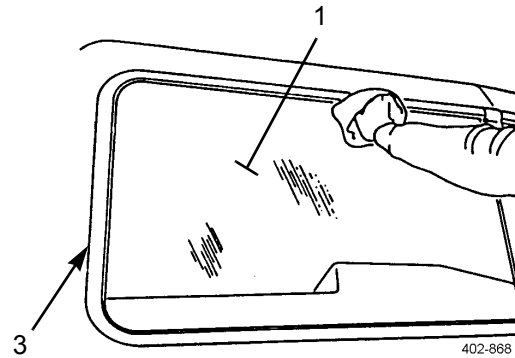

8. Install each windshield glass (1) in center strip of seal (3) until windshield glass bottoms out in channel of seal.
9. Install outside edge of seal (3) on outside edge of each windshield glass (1) until windshield glass bottoms out in channel of seal.
10. Install remainder of seal (3) on each windshield glass (1) until windshield glass bottoms out in channel of seal.

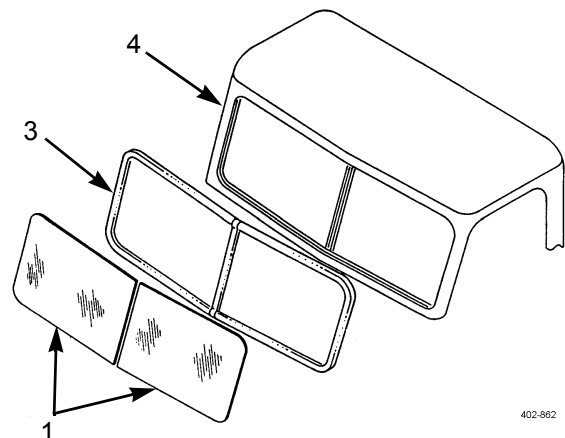

**INSTALLATION - CONTINUED**

11. Using windshield pick, go all the way around between each windshield glass (1) and seal (3) to make sure seal is properly seated.

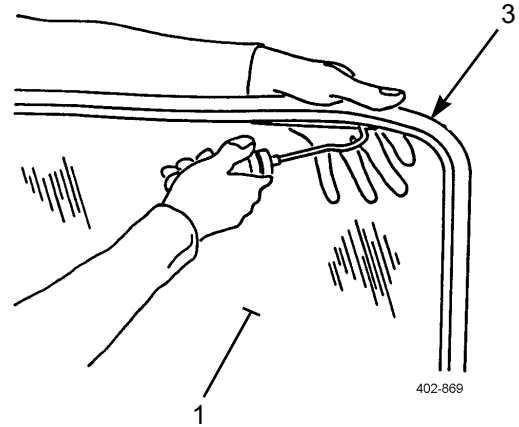

12. Install two cords in outside groove in seal (3) and leave safety loops in center.
13. Using soap and water solution, lubricate cord channel of seal (3).

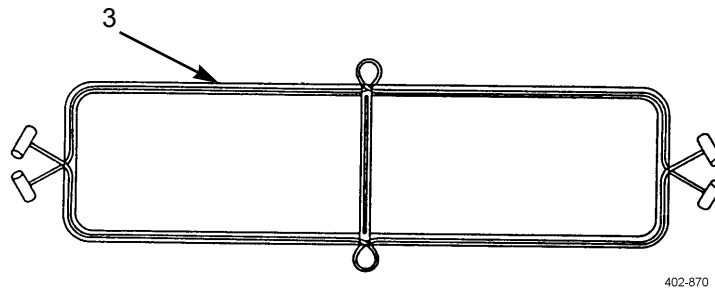

14. Wet mounting flange of cab (4) with clear water.
15. Place windshield glass (1) assembly into windshield opening of cab (4).
16. With assistant pushing lightly on bottom center of windshield glass (1) assembly, pull one end of lower cord around corner of windshield glass assembly; go to other side and pull lower cord around other corner of windshield glass assembly. Have assistant push lightly at top center of windshield assembly. Repeat for top cord.

**NOTE**

- If cord binds or starts to tear seal, use safety loop at center and pull back toward point where cord is bound.
- If safety loop is not needed, it will pull out when cord is pulled to seat final portion of seal.

**INSTALLATION - CONTINUED**

17. With assistant applying light pressure to center of windshield glass (1) assembly, pull both ends of either top or bottom cord alternately until only a few inches from center (pull both ends at same time). Repeat for other cord.

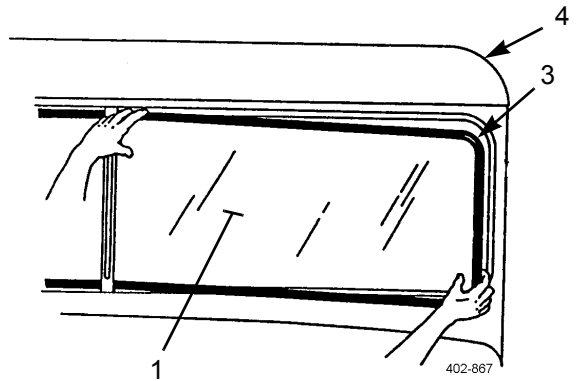

18. Finish seating windshield glass (1) and seal (3) by gently pushing all the way around outside edge.

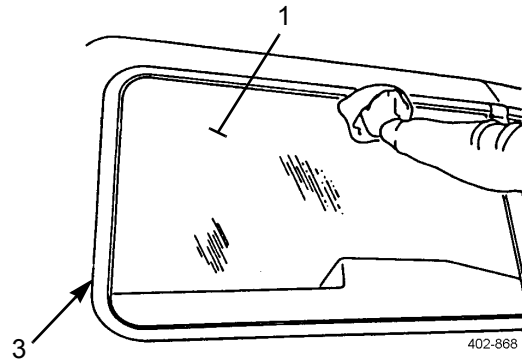

19. Install windshield support (15) with four washers (14) and screws (13).

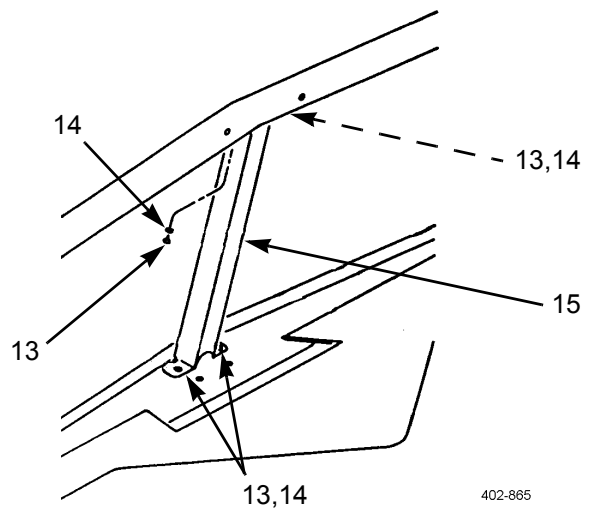

**INSTALLATION - CONTINUED**

- 20. Install cover (10) with two washers (9) and torx screws (8).
- 21. Install defroster vent (11) with torx screw (12).

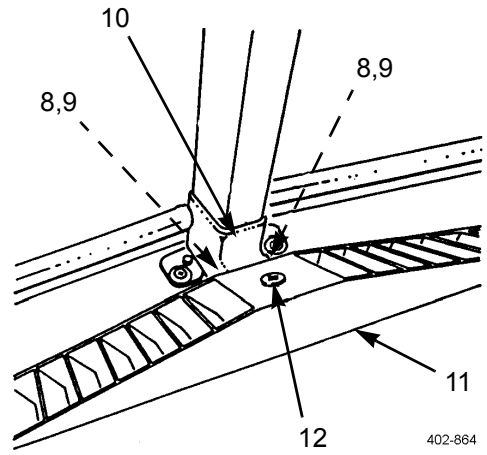

- 22. Install cover (7), two brackets (6), and four torx screws (5).

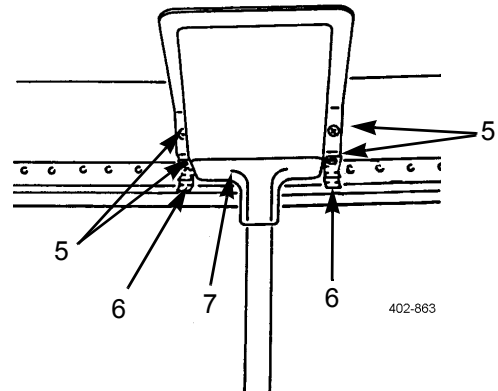

- 23. Install new lockstrip (2).

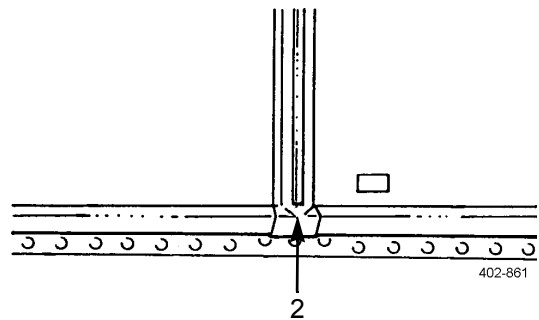

- 24. Install windshield wiper and wiper arms (WP 0199 00).

**END OF WORK PACKAGE**

**REAR WINDOW REPLACEMENT**

**0295 00**

**THIS WORK PACKAGE COVERS**

Removal, Cleaning and Inspection, Installation

**INITIAL SETUP**

**Maintenance Level**

Direct Support

**Tools and Special Tools**

Tool kit, general mechanic's (Item 102, WP 0313 00)

Gloves, welder's (Item 29, WP 0313 00)

**Materials/Parts**

Compound, sealing (Item 15, WP 0312 00)

**Materials/Parts - Continued**

Detergent (Item 18, WP 0312 00)

**Personnel Required**

Two

**References**

WP 0306 00

**Equipment Condition**

Rear window guard removed (TM 9-2320-303-10)

**REMOVAL**

**WARNING**

Wear protective gloves when handling glass. Failure to do so could result in injury to personnel.

**NOTE**

If removing rear window glass only, perform steps 1 through 3. If removing rear window glass and seal, perform steps 1 through 5.

1. If rear window glass (1) is cracked due to any cause other than being hit by a flying object, mark rubber extrusion (2) at location of crack.
2. Using windshield pick, release locking strip (4) from rubber extrusion (2).

**CAUTION**

When handling glass, be careful not to nick or splinter edges. Chipped edges could cause cracking later.

3. Apply pressure to one edge of rear window glass (1) from inside of cab (3). Using windshield pick, lift and remove rear window glass out of rubber extrusion (2).
4. Remove rubber extrusion (2) from cab (3).

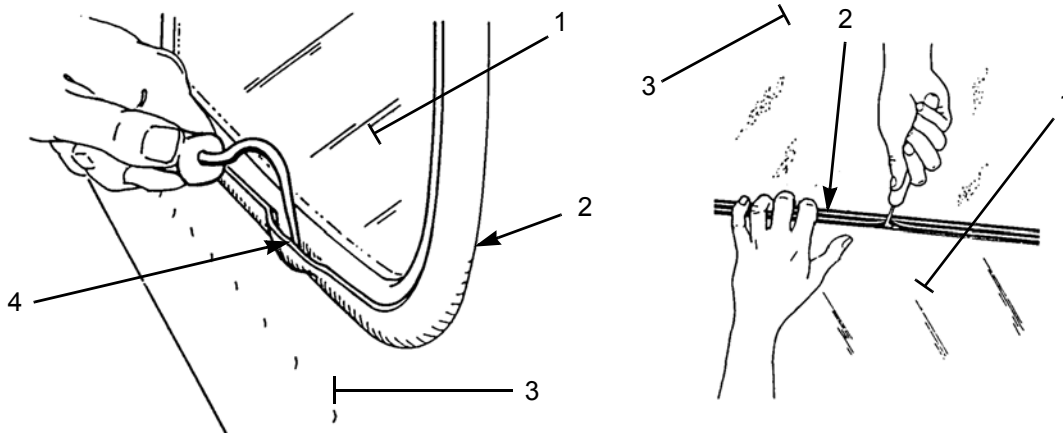

402-871

**REMOVAL - CONTINUED**

5. Remove sealing compound from between ends of rubber extrusion (2).

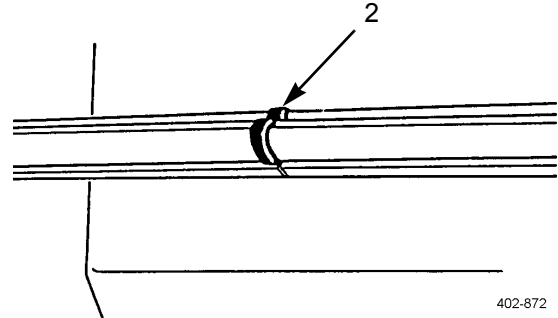

402-872

**CLEANING AND INSPECTION**

1. Use general cleaning methods to clean all parts (WP 0306 00).
2. If rear window glass has been removed under criteria outlined in Removal step 1, inspect channel of rubber extrusion where marked for foreign objects. Inspect mounting flange of cab for irregularities.
3. Inspect all parts for wear or damage.

**INSTALLATION****WARNING**

Wear protective gloves when handling glass. Failure to do so could result in injury to personnel.

**CAUTION**

- When handling glass, be careful not to nick or splinter edges. Chipped edges could cause cracking later.
- Do not use sealant around rear window glass. Sealing compounds are not needed and, if applied unevenly, can cause leaks resulting in water damage.

**NOTE**

If installing rear window glass only, perform steps 1 through 4. If installing rear window glass and seal, perform steps 1 through 6.

1. Lubricate rear window channel of rubber extrusion (2) with detergent and water solution.
2. Slide rear window glass (1) into window channel of rubber extrusion (2) as far as it will go without forcing.
3. Using windshield pick, alternate between top and bottom of rear window glass (1) and work rubber extrusion (2) over edge of rear window glass.



INSTALLATION - CONTINUED

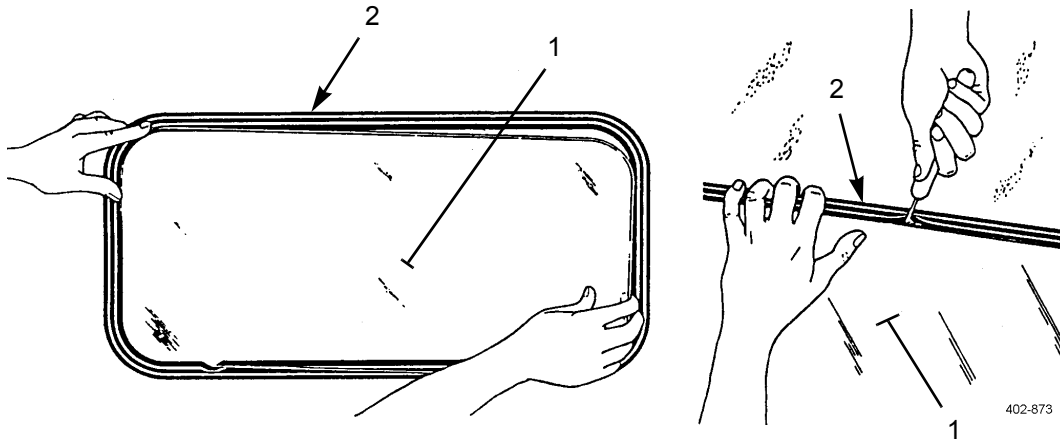

4. Using windshield pick, install locking strip (4) in rubber extrusion (2).

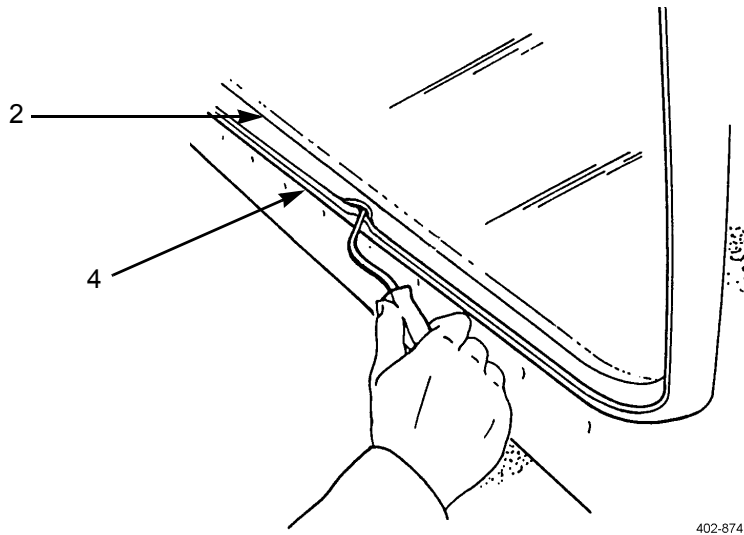

**INSTALLATION - CONTINUED**

5. With locking strip (4) facing out, install rubber extrusion (2) over mounting flange (5) of cab (3).

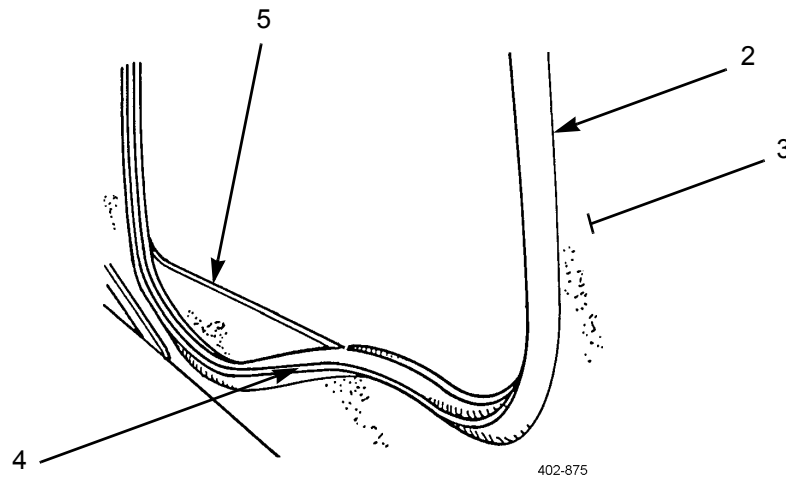

6. Apply sealing compound ONLY at point where both ends of rubber extrusion (2) meet.

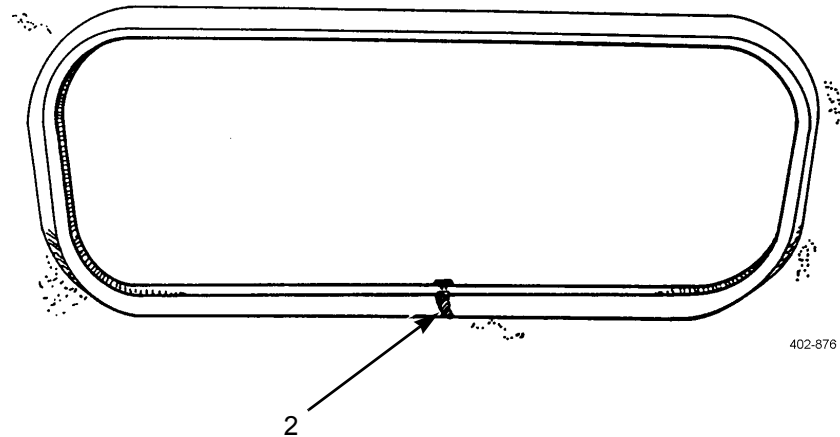

7. Install rear window guard (TM 9-2320-303-10).

**END OF WORK PACKAGE**

**AIR DUCTS REPLACEMENT**

**0296 00**

**THIS WORK PACKAGE COVERS**

Removal, Installation

**INITIAL SETUP**

**Maintenance Level**

Direct Support

**Tools and Special Tools**

Tool kit, general mechanic's (Item 102, WP 0313 00)

**Equipment Condition**

Air system drained (TM 9-2320-303-10)

Dash panels removed for access (WP 0212 00)

**REMOVAL**

1. Remove eight retainers (1) and four air cylinders (2).

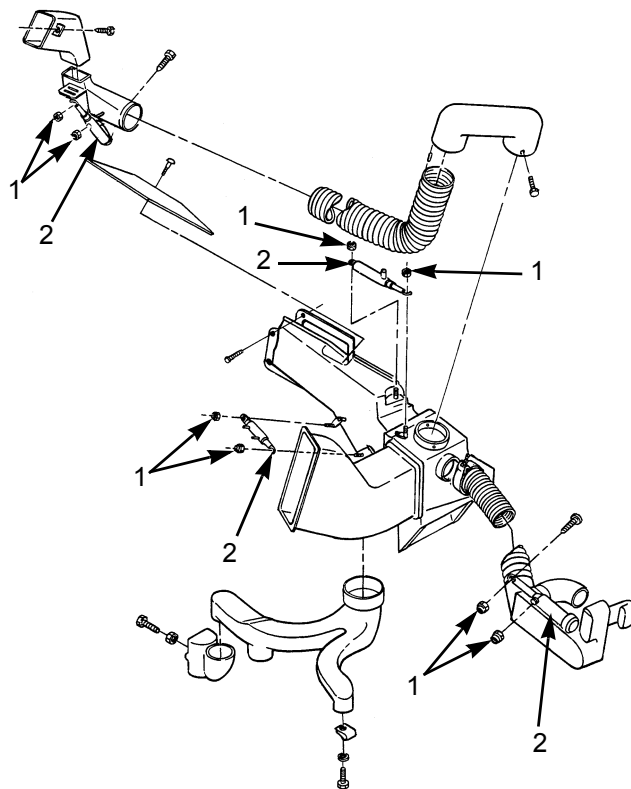

402-877

**REMOVAL - CONTINUED**

2. Remove two self-tapping screws (6) and separate flex tubing (8) from duct (5).
3. Remove two screws (4), duct outlet (3), and duct (5).
4. Remove two self-tapping screws (11), duct (10), and flex tubing (8).
5. Remove five clips (9) and separate flex tubing (8) from duct (10).
6. Remove two self-tapping screws (14) and separate flex tubing (13) from duct outlet (15).
7. Remove hose clamp (12), and flex tubing (13) from face duct (23).
8. Remove self-tapping screw (22), speed nut (21), and outlet duct (20) from duct (19).
9. Remove self-tapping screw (18), washer (17), spring nut (16), and duct (19).
10. Remove screw (7), vent (26), and gasket (25).
11. Remove three self-tapping screws (24) and face duct (23).

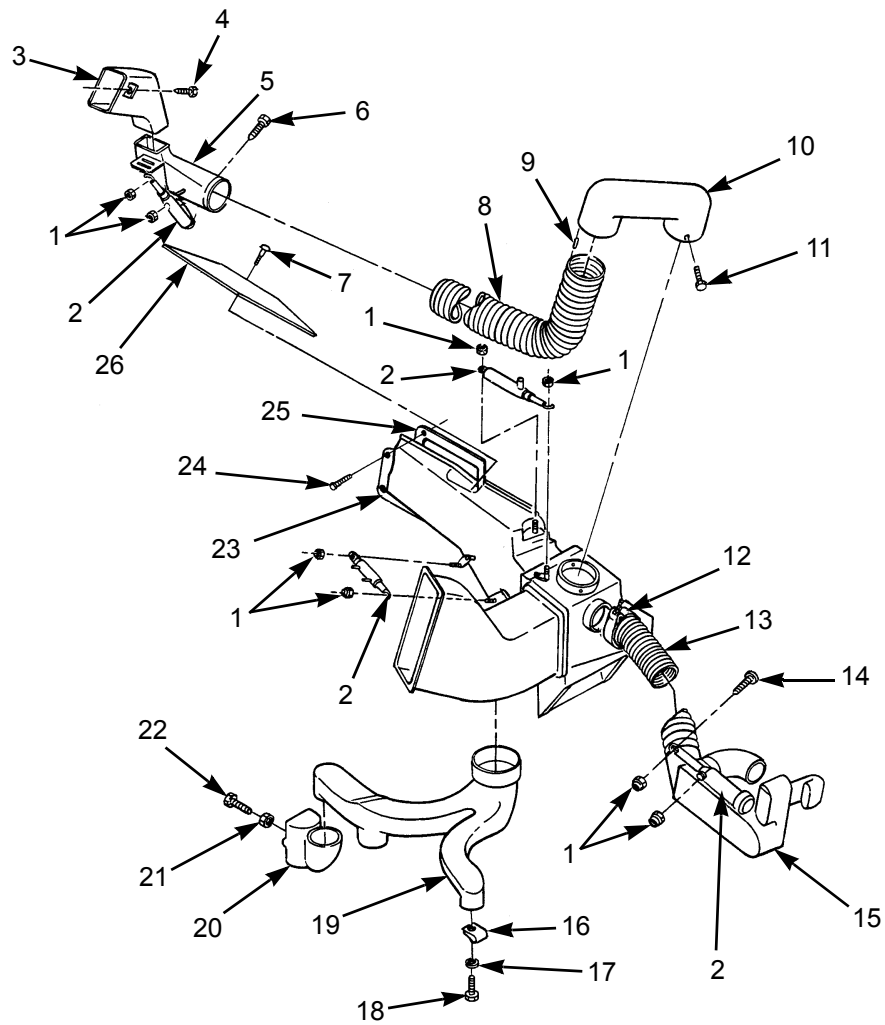

402-877

**INSTALLATION**

1. Install face duct (23) and secure with three self-tapping screws (24).
2. Install gasket (25), vent (26), and secure with screw (7).
3. Install duct (19) and secure with spring nut (16), washer (17), and self-tapping screw (18).
4. Secure outlet duct (20) to duct (19) with speed nut (21) and self-tapping screw (22).
5. Connect flex tubing (13) to duct outlet (15) and secure with two self-tapping screws (14).
6. Connect flex tubing (13) to face duct (23) and secure with hose clamp (12).
7. Connect flex tubing (8) to duct (10) and secure with five clips (9).
8. Connect duct (10) to face duct (23) and secure with two self-tapping screws (11).
9. Connect flex tubing (8) to duct (5) and secure with two self-tapping screws (6).
10. Install duct (5) to duct outlet (3) and secure with two screws (4).
11. Install four air cylinders (2) and secure with eight retainers (1).
12. Install dash panels (WP 0212 00).

**END OF WORK PACKAGE**



**AIR CONDITIONING SYSTEM REFRIGERANT (R-134A) MAINTENANCE****0297 00****THIS WORK PACKAGE COVERS**

Recovery, Evacuating/Recycling, Purging, Flushing, Charging

**INITIAL SETUP****Maintenance Level**

Direct Support

**Tools and Special Tools**

Tool kit, general mechanic's (Item 102, WP 0313 00)

Gloves, protective (Item 27, WP 0313 00)

Goggles (Item 30, WP 0313 00)

Reclaimer, refrigerant (Item 75, WP 0313 00)

Test set (Item 97, WP 0313 00)

**Materials/Parts**

Adhesive, loctite (Item 3, WP 0312 00)

Cap set (Item 8, WP 0312 00)

Oil, refrigerant (Item 34, WP 0312 00)

Refrigerant, R-134a (Item 47, WP 0312 00)

**References**

WP 0218 00

WP 0301 00

**WARNING**

- Use care to prevent refrigerant from touching your skin or eyes. Liquid refrigerant, when exposed to air, quickly evaporates and will freeze skin or eye tissue. Serious injury or blindness may result if you come in contact with liquid refrigerant.
- Refrigerant R-134a air conditioning systems should not be pressure tested or leak tested with compressed air. Combustible mixtures of air and R-134a may form, resulting in a fire or explosion, which could cause personnel injury or death.
- Refrigerant capacity is 2.9 lb (1.3 kg).

**RECOVERY**

1. Remove caps from suction and discharge valves. Valves are located at firewall on passenger side of vehicle.
2. Wearing protective goggles and non-leather gloves, attach recovery/recycling station's hoses to valves.

**NOTE**

Push down firmly on hose connectors until a clicking sound is heard. This will ensure coupler is locked.

- a. Ensure recovery/recycling station's valves are closed.
- b. Connect red high-side hose to discharge service valve.
- c. Connect blue low-side hose to suction service valve.
- d. Turn knob clockwise on each coupler to open shradar valves.

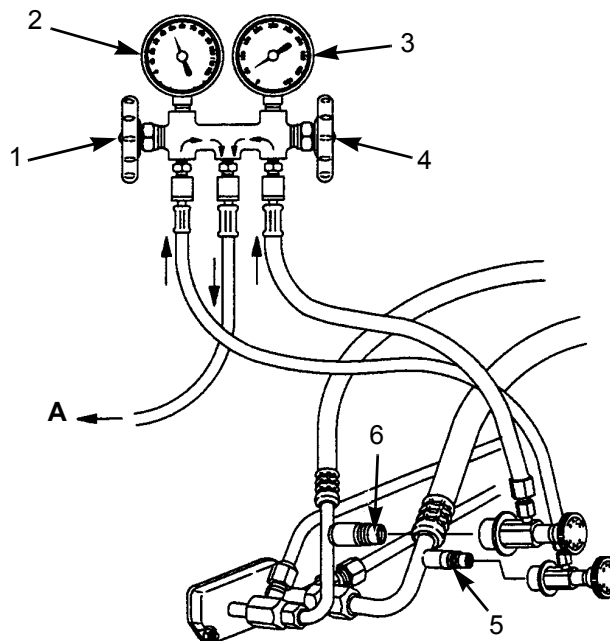

**A To Recovery Station**

- 1 Manifold Suction Hand Valve (Open)
- 2 Low-Side Gage
- 3 High-Side Gage
- 4 Manifold Discharge Hand Valve (Open)
- 5 Suction Service Valve
- 6 Discharge Service Valve

402-878

3. Follow recovery/recycling manufacturer's instructions and recover all refrigerant from system.

**NOTE**

- Always comply with all local regulations regarding refrigerant disposal. You may be subject to substantial penalties for improper disposal.

**NOTE**

If system is contaminated with moisture, compressor oil must be replaced with clean oil. If system is heavily contaminated with desiccant or grit, replace compressor and expansion valve.

4. Service air conditioner compressor (WP 0301 00).



**EVACUATING/RECYCLING****NOTE**

System must have been recovered and compressor filled with correct amount of refrigerant oil. Replace receiver-dryer if system is opened.

1. Wearing protective goggles and non-leather gloves, attach recovery/recycling station's hoses to valves.

**NOTE**

Push down firmly on hose connectors until a clicking sound is heard. This will ensure coupler is locked.

- a. Ensure recovery/recycling station's valves are closed.
  - b. Connect red high-side hose to discharge service valve.
  - c. Connect blue low-side hose to suction service valve.
  - d. Turn knob clockwise on each coupler to open schrader valves.
2. Follow recovery/recycling manufacturer's instructions and evacuate/recycle refrigerant system.

**PURGING**

**NOTE**

Dry nitrogen gas is recommended for purging. A pressure regulator is required to regulate between 0 to 200 psi (0-1379 kPa). Commercial cylinders of nitrogen contain pressures in excess of 2000 psi (13,780 kPa); this pressure must be reduced to 200 psi (1379 kPa) for purging.

1. Recover system refrigerant.
2. Disconnect both ends of line or part being purged. Tightly cap rest of system.
3. Ensure valves (8, 7, and 11) are closed.

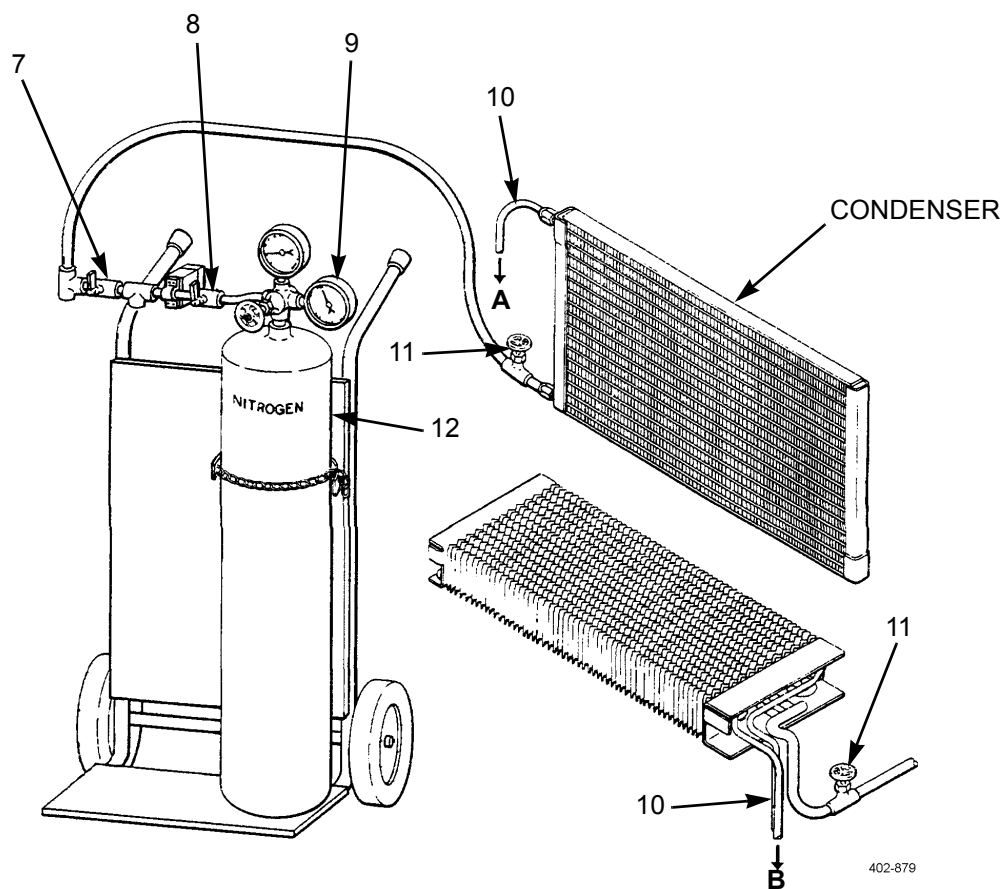

<p><b>A</b>      <b>To Waste Container</b></p> <p>7      Purging Control Valve</p> <p>8      Nitrogen Bottle Control Valve</p> <p>11     Supply Line Valve</p>	<p><b>B</b>      <b>To Recycling System Container</b></p> <p>9      Nitrogen Bottle Regulator/Gage</p> <p>10     Drain Line</p> <p>12     Nitrogen Bottle</p>
--	---

4. Connect supply line valve (11) to outlet end of part or line.
5. Connect drain line (10) to inlet end of part or line.
6. Place outlet of drain line (10) into a recycling system container.

**PURGING - CONTINUED**

7. Adjust nitrogen bottle regulator (9) to 200 psi (1379 kPa). Open nitrogen bottle control valve (8) and purging control valve (7). Then, slowly open supply line valve (11). Check drain line (10) for gas flow.
8. Let nitrogen flow at 200 psi (1379 kPa) and let it flow for 1 to 2 minutes. If part or line was very wet, allow it to flow until there is no trace of refrigerant oil or solid bits of dirt or grit flowing from drain tube.
9. Close nitrogen bottle control valve (8) and purging control valve (7) first, then close supply line valve (11).
10. Disconnect supply line valve (11) and drain line (10). Tightly cap both ends of part or line.

**FLUSHING**

1. Recover refrigerant system.
2. Disconnect both ends of part or line being flushed. Tightly cap lines to rest of system.
3. Heat R-134a refrigerant in a dial-a-charge or pressurize refrigerant as recommended by manufacturer.
4. Connect dial-a-charge outlet hose to outlet side of system (this will ensure that R-134a will flow in reverse direction of normal flow).
5. Connect a line from inlet side of system to a recovery/recycling station.

**NOTE**

If system is extremely contaminated, install a receiver-dryer inline as a pre-filter for recovery/recycling station.

6. Turn on recovery/recycling station and open outlet valve for dial-a-charge. Allow about 2 pounds (1 kilogram) of R-134a to flow through system.
7. Close supply line valve and wait for recovery station to shut off.
8. Disconnect supply line and drain line from dial-a-charge and recovery station. Connect lines to nitrogen bottle.
9. Purge system and check collection bottle for contaminants. Repeat process if needed.
10. Disconnect lines from part and tightly cap both ends of part.

**CHARGING****NOTE**

- Refrigerant capacity is 2.9 lb (1.3 kg).
- Before charging, system must be recovered and evacuated with recovery and recycling station connected to service and discharge port connections.

1. Obtain enough refrigerant to fully charge system. Set tank on a scale and weigh for correct amount of refrigerant to enter system. This prevents overcharging, which could cause damage to compressor.
2. Charge refrigerant system:

**NOTE**

If equipped with a recovery, recycling, and recharging system, charge system on high side following manufacturer's instructions. If charging from a bulk container, perform following steps:

- a. Turn tank (bulk container) upside down. With engine off, open high side hand valve. DO NOT open low side hand valve.
- b. Allow refrigerant to enter system until correct charge (by weight) has entered. Close high side hand valve.

**CHARGING - CONTINUED**

- c. Start engine and run it at 1500 rpm. Set cab air conditioner controls at maximum cooling and fan speed; refrigerant compressor must engage.
- d. If a charge did not enter system, place tank (bulk container) in upright position, then open LOW SIDE valve to draw vapor into system; leave valve open until correct weight of refrigerant has entered system, then close low side valve.

**NOTE**

If refrigerant is slow to enter system because of low outside temperatures, vaporization can be quickened by placing refrigerant tank in a tub of warm water, no warmer than 125°F (52°C).

3. Disconnect high side hose. With engine running, open low side and high side hose valves to recover refrigerant from lines.
4. Shut down engine.
5. Leak test air conditioning system (WP 0218 00).
6. Check operation of air conditioning system (TM 9-2320-303-10).

**END OF WORK PACKAGE**

**HEATING, VENTILATION, AIR CONDITIONING (HVAC) UNIT REPLACEMENT****0298 00****THIS WORK PACKAGE COVERS**

Removal, Installation

**INITIAL SETUP****Maintenance Level**

Direct Support

**Tools and Special Tools**

Tool kit, general mechanic's (Item 102, WP 0313 00)

Dispenser, sealant (Item 19, WP 0313 00)

Gloves, protective (Item 27, WP 0313 00)

Goggles (Item 30, WP 0313 00)

Wrench, torque, 15-75 lb-ft (Item 110, WP 0313 00)

**Materials/Parts**

Adhesive, loctite (Item 3, WP 0312 00)

Cap set (Item 8, WP 0312 00)

Compound, gasket forming (Item 14, WP 0312 00)

**Materials/Parts - Continued**

Oil, refrigerant (Item 34, WP 0312 00)

Rags, wiping (Item 39, WP 0312 00)

Tags, marker (Item 42, WP 0312 00)

Tape, insulation (Item 46, WP 0312 00)

**Personnel Required**

Two

**References**

WP 0218 00

WP 0301 00

WP 0305 00

**Equipment Condition**

Cooling system drained (WP 0045 00)

Refrigerant recovered (WP 0297 00)

**WARNING**

- Use care to prevent refrigerant from touching your skin or eyes. Liquid refrigerant, when exposed to air, quickly evaporates and will freeze skin or eye tissue. Serious injury or blindness may result if you come in contact with liquid refrigerant.
- Refrigerant R-134a air conditioning systems should not be pressure tested or leak tested with compressed air. Combustible mixtures of air and R-134a may form, resulting in a fire or explosion, which could cause personnel injury or death.

**REMOVAL**

**NOTE**

Tag all lines and wires prior to removal to aid in installation.

1. Remove nine screws (1) and cover (2).
2. Remove three screws (6) and cover (5).
3. Remove two screws (4) and cover (3).

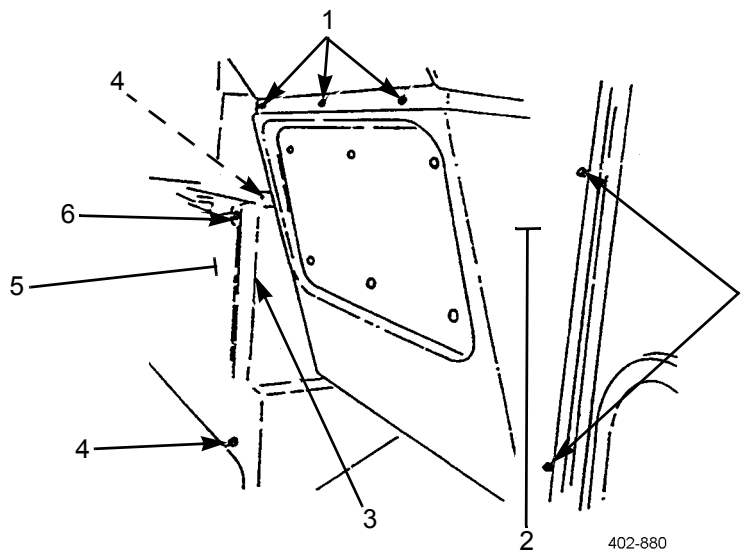

4. Remove seven screws (7) and cover (8) from dash (9).

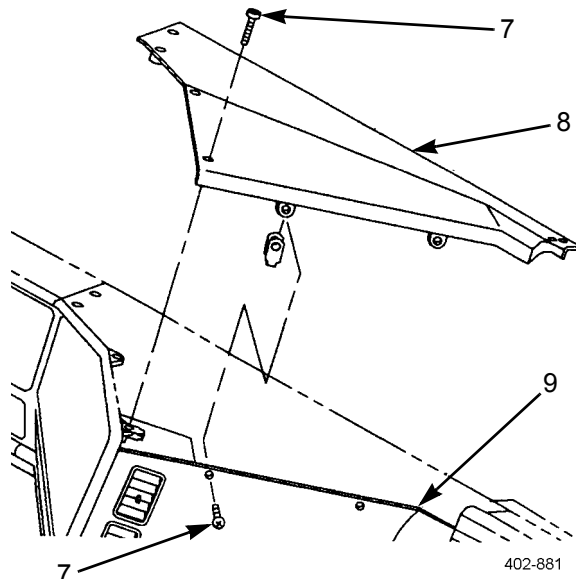

**REMOVAL - CONTINUED**

5. Open glove box door (13) and remove two screws (10) and top panel (11) from compartment (12).
6. Remove three nuts (14), spring washers (15), and compartment (12) from dash (9).

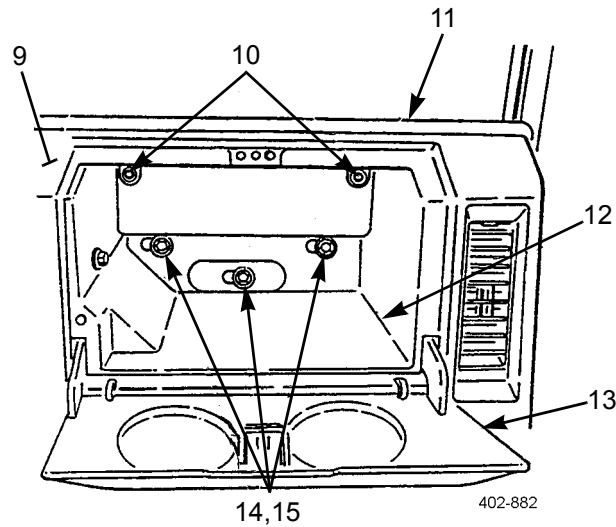

7. Disconnect two flex hoses from ducts behind compartment (12).
8. Disconnect blue air line from air cylinder behind compartment (12).
9. Disconnect connectors for blower motor (17), resistor block (16), and thermostatic switch (18).

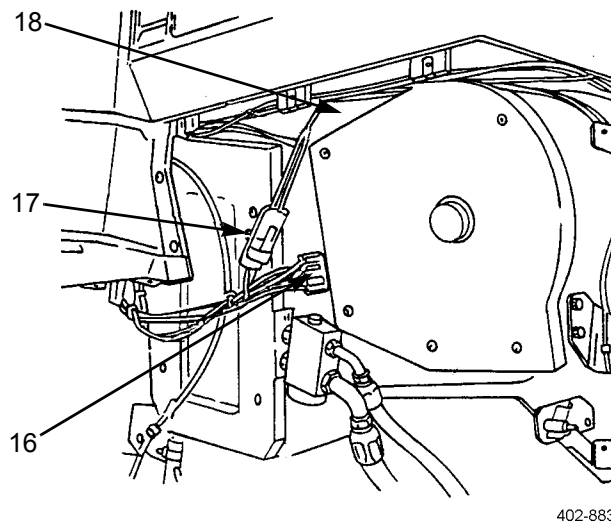

**REMOVAL - CONTINUED**

10. Place rags on cab floor, loosen two hose clamps (22), and remove two heater core hoses (21).
11. Loosen two hose clamps (19) and remove two drain tubes (20).

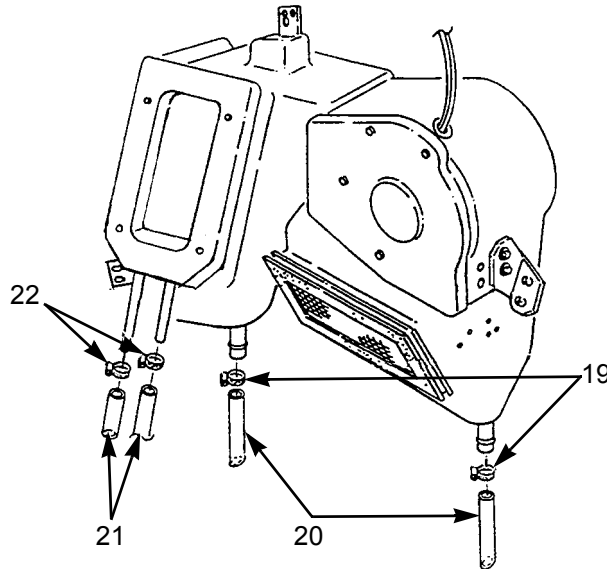

402-884

12. On cab floor (23), remove sealant (24) from drain tubes (20) and remove drain tubes.

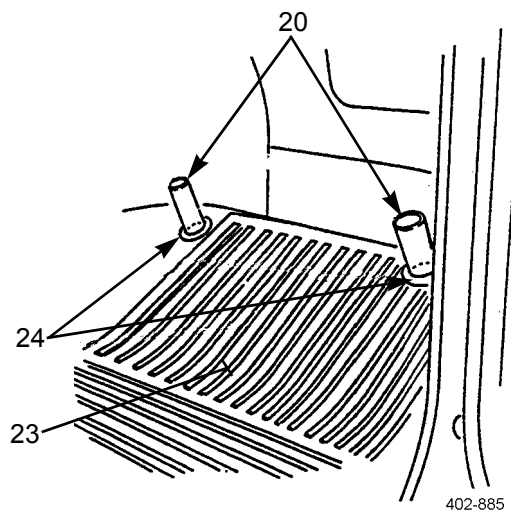

402-885

**WARNING**

Use care to prevent refrigerant from touching your skin or eyes. Liquid refrigerant, when exposed to air, quickly evaporates and will freeze skin or eye tissue. Serious injury or blindness may result if you come in contact with liquid refrigerant.



**REMOVAL - CONTINUED****CAUTION**

Water and dirt can damage refrigerant system. Five minutes of not being capped is the limit for any hose or component. DO NOT blow shop air through refrigerant hoses. Shop air is wet (humid).

**NOTE**

DO NOT disconnect refrigerant fittings using only one wrench. Hold one fitting in place using a wrench and turn other fitting with a second wrench.

13. Remove insulation tape from expansion valve (26). Disconnect two refrigerant lines (25) from expansion valve.
14. Cap expansion valve (26) and refrigerant lines (25).

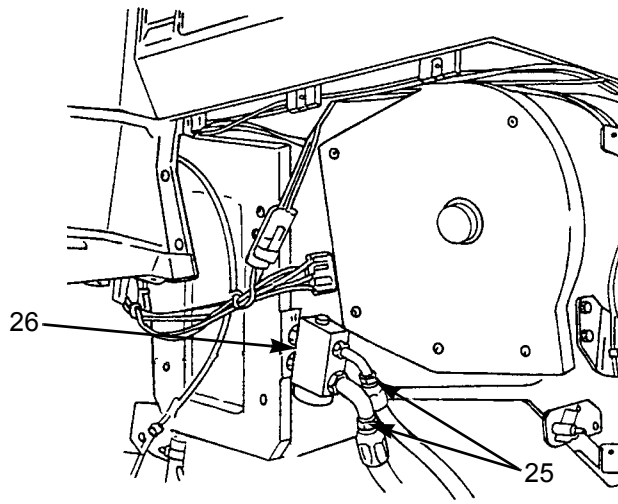

402-886

15. Remove six screws (27) and fresh air duct assembly (28) on engine side of cab firewall.
16. Remove gasket forming compound from duct and push rubber boot inside cab.

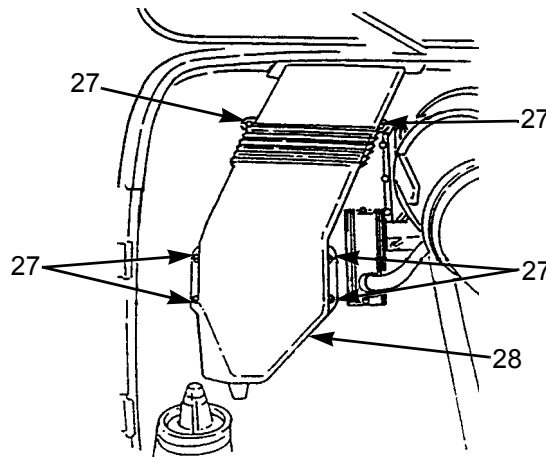

402-887

**REMOVAL - CONTINUED**

17. Disconnect air line (29) from air cylinder (30) by pushing in on cover ring, then pulling out on air line.

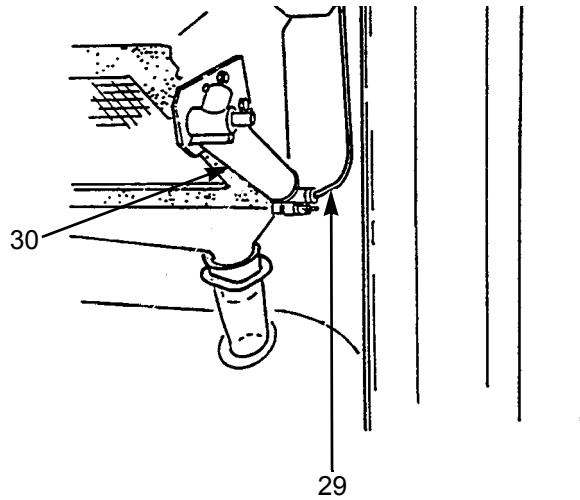

402-888

18. Remove six screws (31) holding HVAC unit (32) in place.
19. With assistance, lift HVAC unit (32) from vehicle.

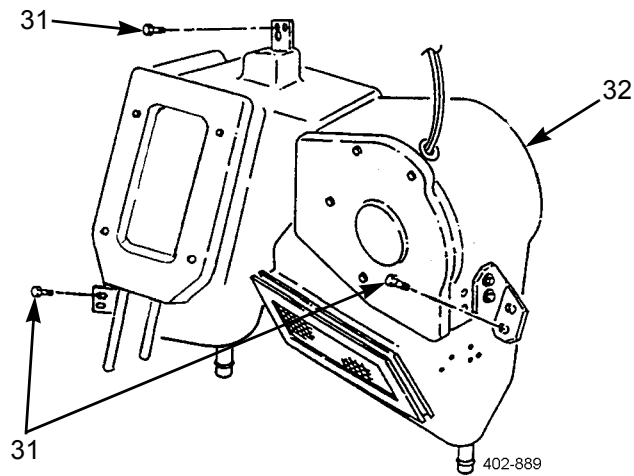

402-889

**INSTALLATION**

1. With assistance, lift HVAC unit (32) into vehicle.
2. Secure HVAC unit (32) with six screws (31). Tighten screws to 48 lb-ft (65 Nm).
3. Connect air line (29) to air cylinder (30) by pushing air line into fitting as far as it will go, then gently pulling back on air line to lock it in place.
4. Pull rubber boot through firewall from engine side.
5. On engine side of fire wall, apply gasket forming compound to fresh air duct assembly (28) and secure with six screws (27).

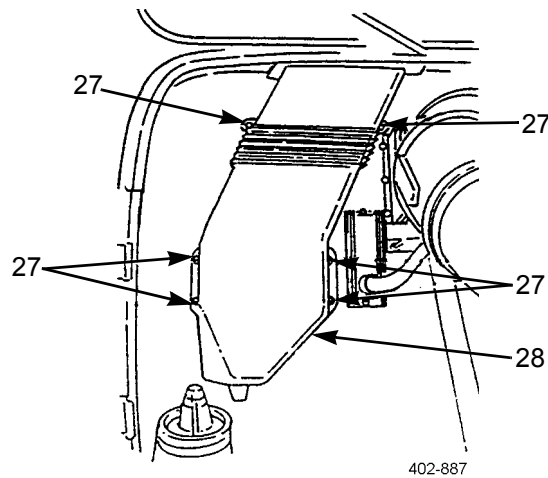

6. Slide drain tubes (20) through openings in cab floor (23).

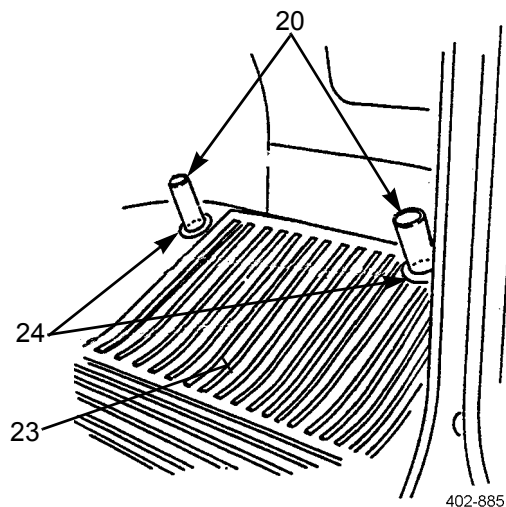

**INSTALLATION - CONTINUED**

7. Connect two drain tubes (20) and secure with two hose clamps (19).
8. Install two heater core hoses (21) and tighten two hose clamps (22).

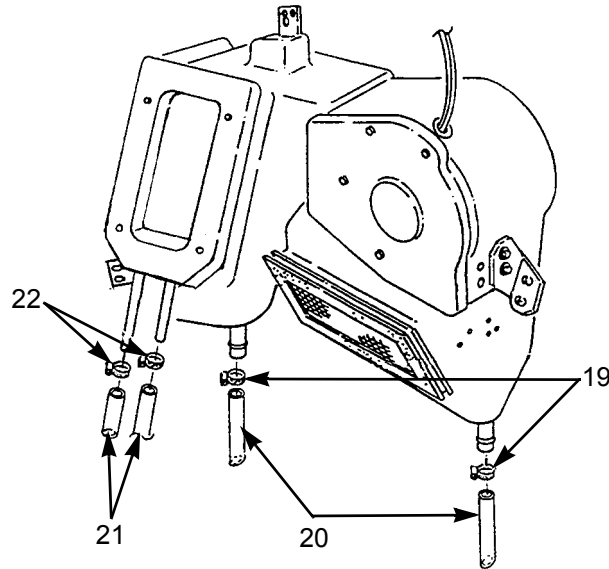

402-884

9. Apply sealant (24) around drain tubes (20) on cab floor (23).

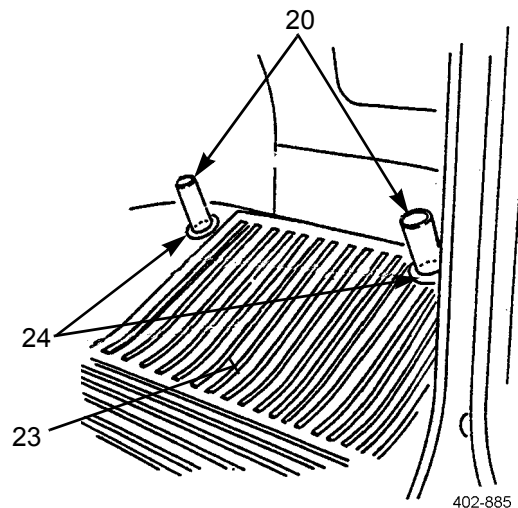

402-885

**WARNING**

Use care to prevent refrigerant from touching your skin or eyes. Liquid refrigerant, when exposed to air, quickly evaporates and will freeze skin or eye tissue. Serious injury or blindness may result if you come in contact with liquid refrigerant.

10. Remove caps from refrigerant lines (25) and expansion valve (26).

**INSTALLATION - CONTINUED**

11. Install new preformed packings (33) and lubricate them with refrigerant oil.
12. Apply loctite to male fitting threads (34) and connect two refrigerant lines (25) to expansion valve (26). Remove tags.
13. Torque refrigerant line connections (WP 0164 00).

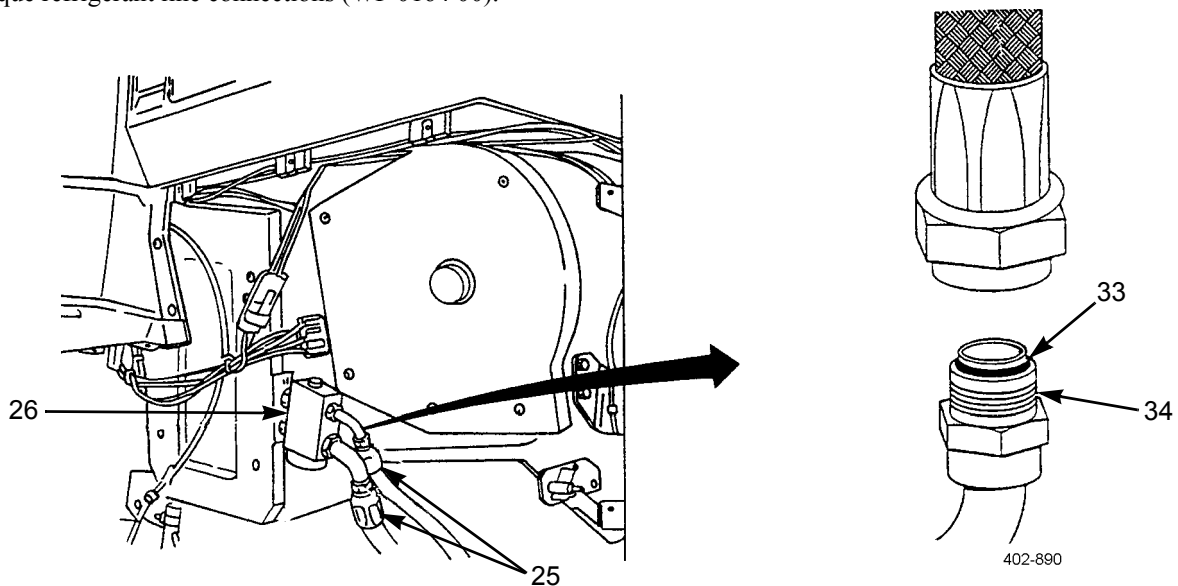

14. Apply insulation tape to refrigerant lines (25) and expansion valve (26).
15. Connect connectors for blower motor (17), resistor block (16), and thermostatic switch (18).

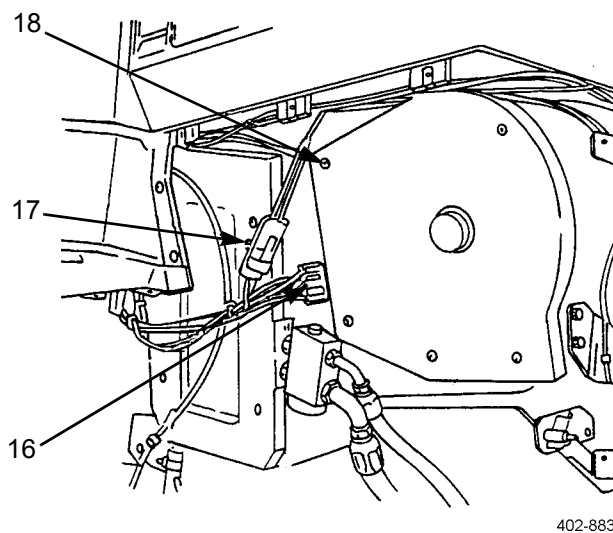

16. Connect blue air line to air cylinder behind compartment (12).
17. Connect two flex hoses to ducts behind compartment (12).

**INSTALLATION - CONTINUED**

18. Charge system with refrigerant (WP 0297 00).
19. Add refrigerant oil to compressor to replace that which was lost during system discharge (WP 0301 00).



**WARNING**

Refrigerant R-134a air conditioning systems should not be pressure tested or leak tested with compressed air. Combustible mixtures of air and R-134a may form, resulting in a fire or explosion, which could cause personnel injury or death.

20. Leak test air conditioner system (WP 0218 00).
21. Install compartment (12) into dash (9) and secure with three nuts (14) and spring washers (15).
22. Install top panel (11) to compartment (12) and secure with two screws (10).

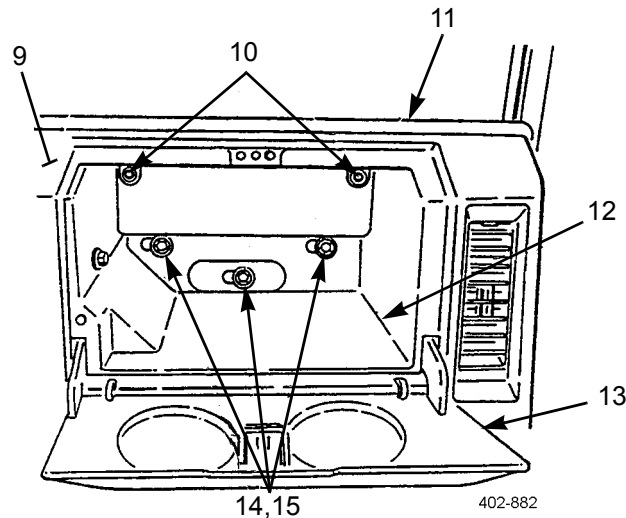

23. Position cover (8) on dash (9) and secure with seven screws (7).

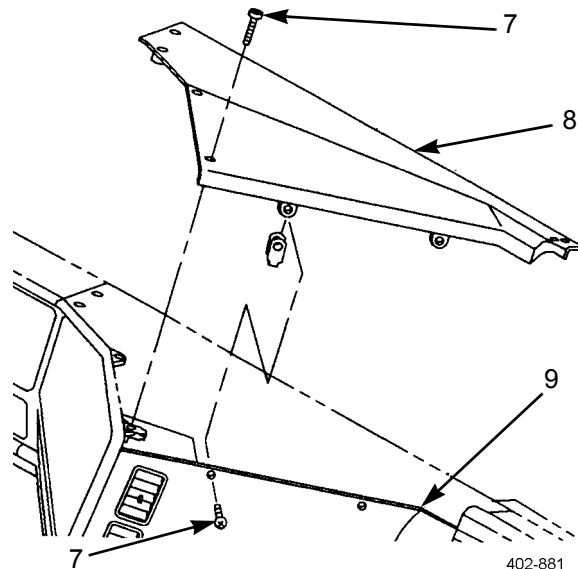

**INSTALLATION - CONTINUED**

24. Position cover (3) on dash (9) and secure with two screws (4).
25. Position cover (5) on dash (9) and secure with three screws (6).
26. Position cover (2) on dash (9) and secure with nine screws (1).

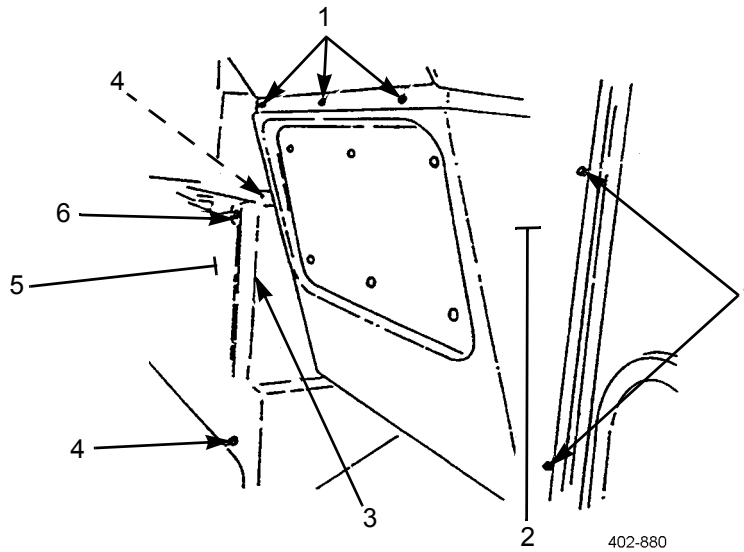

27. Fill cooling system (WP 0045 00).

**END OF WORK PACKAGE**





**AIR CONDITIONER EXPANSION VALVE REPLACEMENT****0299 00****THIS WORK PACKAGE COVERS**

Removal, Installation

**INITIAL SETUP****Maintenance Level**

Direct Support

**Tools and Special Tools**

Tool kit, general mechanic's (Item 102, WP 0313 00)

Crowfoot attachment set (Item 16, WP 0313 00)

Gloves, protective (Item 28, WP 0313 00)

Goggles (Item 30, WP 0313 00)

Wrench, torque, 0-300 lb-in (Item 109, WP 0313 00)

Wrench, torque, 15-75 lb-ft (Item 110, WP 0313 00)

**Materials/Parts**

Adhesive, loctite (Item 3, WP 0312 00)

Cap set (Item 8, WP 0312 00)

Caulk, strip (Item 9, WP 0312 00)

**Materials/Parts - Continued**

Oil, refrigerant (Item 34, WP 0312 00)

Rags, wiping (Item 39, WP 0312 00)

Tags, marker (Item 42, WP 0312 00)

Tape, insulation (Item 46, WP 0312 00)

Packing, preformed (P/N B0A/8020400219)

Packing, preformed (P/N B0A/8020400229)

**References**

WP 0218 00

WP 0301 00

**Equipment Condition**

Refrigerant recovered (WP 0297 00)

**WARNING**

- Use care to prevent refrigerant from touching your skin or eyes. Liquid refrigerant, when exposed to air, quickly evaporates and will freeze skin or eye tissue. Serious injury or blindness may result if you come in contact with liquid refrigerant.
- Refrigerant R-134a air conditioning systems should not be pressure tested or leak tested with compressed air. Combustible mixtures of air and R-134a may form, resulting in a fire or explosion, which could cause personnel injury or death.

**REMOVAL****NOTE**

Tag all lines and wires prior to removal to aid in installation.

1. Remove nine screws (1) and cover (2).

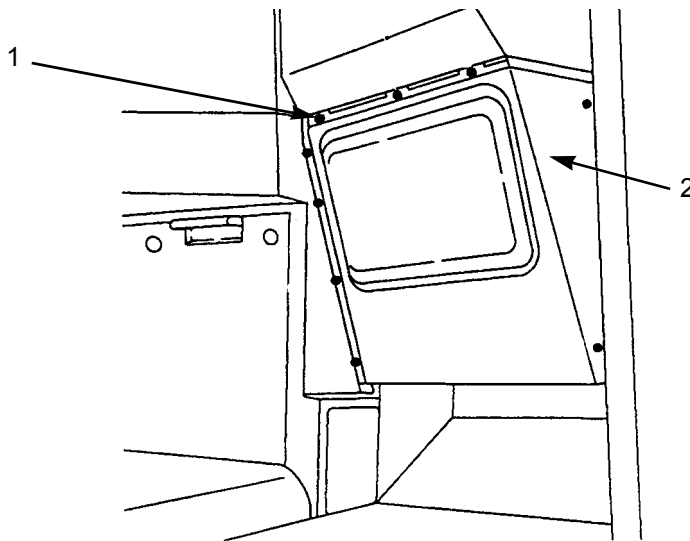

402-891

**WARNING**

Use care to prevent refrigerant from touching your skin or eyes. Liquid refrigerant, when exposed to air, quickly evaporates and will freeze skin or eye tissue. Serious injury or blindness may result if you come in contact with liquid refrigerant.

2. Remove insulation tape and strip caulk around expansion valve (4).

**CAUTION**

Water and dirt can damage refrigerant system. Five minutes of not being capped is the limit for any hose or component. **DO NOT** blow shop air through refrigerant hoses. Shop air is wet (humid).

**NOTE**

**DO NOT** disconnect refrigerant fittings using only one wrench. Hold one fitting in place using a wrench and turn other fitting with a second wrench.

3. Tag and disconnect refrigerant lines (3) and evaporator coil inlet and outlet lines (5) from expansion valve (4). Install plugs in refrigerant lines, evaporator coil inlet and outlet lines, and expansion valve. Discard preformed packings.

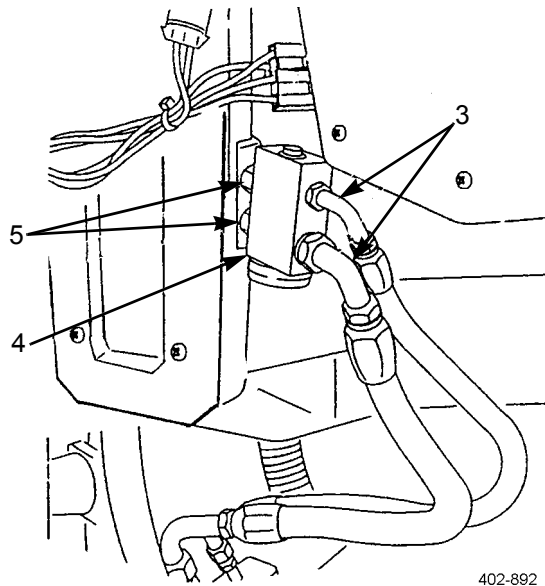
**REMOVAL - CONTINUED**

402-892

4. Remove expansion valve (4).

**INSTALLATION**

1. Remove plugs from refrigerant lines (3), evaporator coil inlet and outlet lines (5), and expansion valve (4).
2. Install new preformed packings and lubricate with refrigerant oil.
3. Apply loctite to male fitting threads and connect refrigerant lines (3) and evaporator coil inlet and outlet lines (5) to expansion valve (4).

**NOTE**

DO NOT connect refrigerant fittings using only one wrench. Hold one fitting in place using a wrench and turn other fitting with a second wrench.

4. Using wrenches, tighten evaporator coil lines (5) to 216 lb-in (25 Nm).
5. Tighten refrigerant lines (3): tighten large hose to compressor to 24 lb-ft (33 Nm); tighten small hose from receiver-dryer to 144 lb-in (16 Nm).
6. Evacuate and charge system with refrigerant (WP 0297 00).
7. Add refrigerant oil to compressor to replace that which was lost during system discharge (WP 0301 00).

**WARNING**

Use care to prevent refrigerant from touching your skin or eyes. Liquid refrigerant, when exposed to air, quickly evaporates and will freeze skin or eye tissue. Serious injury or blindness may result if you come in contact with liquid refrigerant.

8. Leak test air conditioner system (WP 0218 00).

**INSTALLATION - CONTINUED**

9. Wipe expansion valve (4) and refrigerant line (3) connections clean. Wrap line connections with insulation tape.

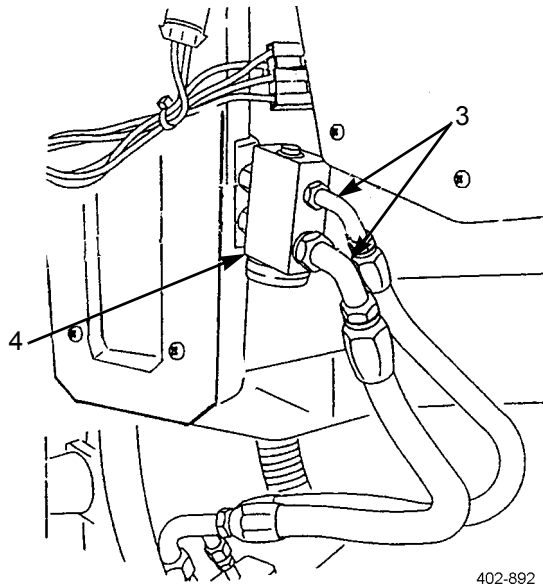

402-892

10. Wrap expansion valve (4) with strip caulk.
11. Install dash panel (2) and nine screws (1).

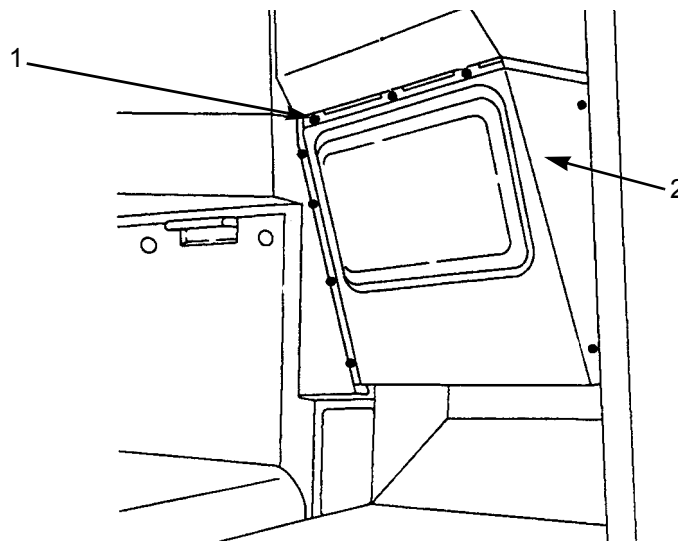

402-891

**END OF WORK PACKAGE**

**AIR CONDITIONER EVAPORATOR COIL REPLACEMENT**

**0300 00**

**THIS WORK PACKAGE COVERS**

Removal, Installation

**INITIAL SETUP**

**Maintenance Level**

Direct Support

**Tools and Special Tools**

Tool kit, general mechanic's (Item 102, WP 0313 00)

Crowfoot attachment set (Item 16, WP 0313 00)

Gloves, protective (Item 28, WP 0313 00)

Goggles (Item 30, WP 0313 00)

Wrench, torque, 0-300 lb-in (Item 109, WP 0313 00)

Wrench, torque, 15-75 lb-ft (Item 110, WP 0313 00)

**Materials/Parts**

Adhesive, loctite (Item 3, WP 0312 00)

Cap set (Item 8, WP 0312 00)

Caulk, strip (Item 9, WP 0312 00)

**Materials/Parts - Continued**

Oil, refrigerant (Item 34, WP 0312 00)

Rags, wiping (Item 39, WP 0312 00)

Tags, marker (Item 42, WP 0312 00)

Tape, insulation (Item 46, WP 0312 00)

Packing, preformed (P/N B0A/8020400219)

Packing, preformed (P/N B0A/8020400229)

**References**

WP 0214 00

WP 0218 00

WP 0301 00

**Equipment Condition**

Refrigerant recovered (WP 0297 00)



**WARNING**



- Use care to prevent refrigerant from touching your skin or eyes. Liquid refrigerant, when exposed to air, quickly evaporates and will freeze skin or eye tissue. Serious injury or blindness may result if you come in contact with liquid refrigerant.
- Refrigerant R-134a air conditioning systems should not be pressure tested or leak tested with compressed air. Combustible mixtures of air and R-134a may form, resulting in a fire or explosion, which could cause personnel injury or death.

**REMOVAL**

**NOTE**

Tag all lines and wires prior to removal to aid in installation.

**REMOVAL - CONTINUED**

1. Remove nine screws (1) and cover (2).

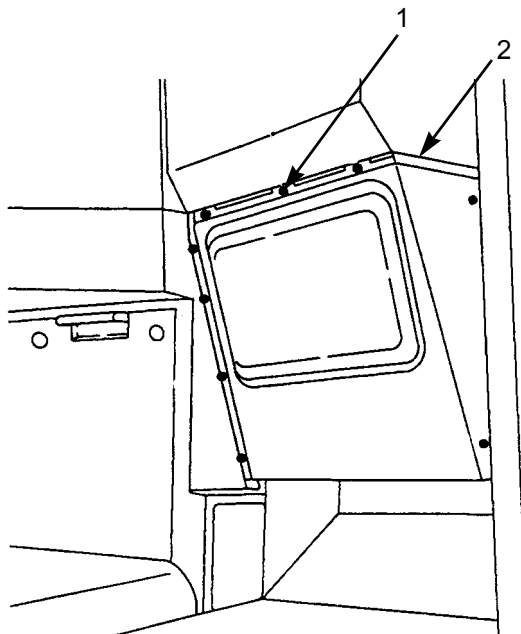

402-891

**WARNING**

Use care to prevent refrigerant from touching your skin or eyes. Liquid refrigerant, when exposed to air, quickly evaporates and will freeze skin or eye tissue. Serious injury or blindness may result if you come in contact with liquid refrigerant.

2. Remove insulation tape and strip caulk around expansion valve (3).
3. Remove four screws (6) and cover (5).

**CAUTION**

Water and dirt can damage refrigerant system. Five minutes of not being capped is the limit for any hose or component. DO NOT blow shop air through refrigerant hoses. Shop air is wet (humid).

**NOTE**

DO NOT disconnect refrigerant fittings using only one wrench. Hold one fitting in place using a wrench and turn other fitting with a second wrench.

4. Tag and disconnect refrigerant lines (4) and evaporator coil inlet and outlet lines (7) from expansion valve (3). Install plugs in refrigerant lines, evaporator coil inlet and outlet lines, and expansion valve. Discard preformed packings.

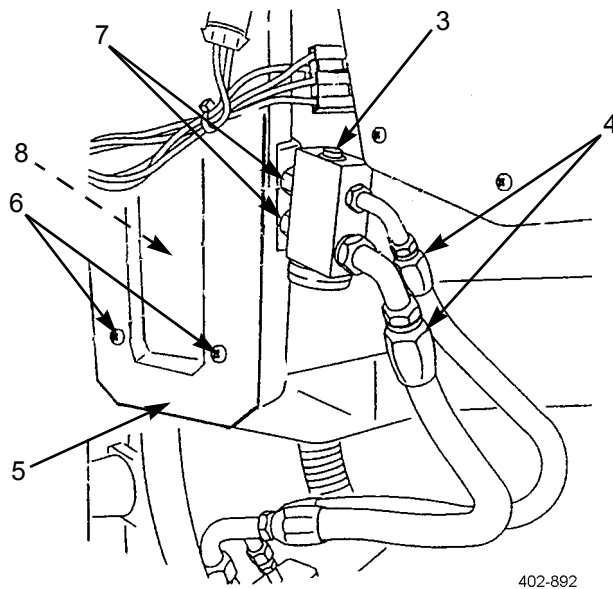
**REMOVAL - CONTINUED**

- Remove thermostatic switch and sensor tube from evaporator coil (WP 0214 00).

**WARNING**

Failure to wear protective gloves could result in serious skin cuts due to sharp edges on evaporator coil fins.

- Wearing protective gloves, slide evaporator coil (8) up and out of housing

**INSTALLATION**

- Wearing protective gloves, slide evaporator coil (8) into housing.
- Insert thermostatic switch and sensor tube. Tip of sensor tube must be in direct contact with a fin and be inserted at least 4 inches (10 cm) into evaporator (WP 0214 00).
- Remove plugs from refrigerant lines (4), evaporator coil inlet and outlet lines (7), and expansion valve (3).
- Install new preformed packings and lubricate with refrigerant oil.
- Apply loctite to male fitting threads and connect refrigerant lines (4) and evaporator coil inlet and outlet lines (7) to expansion valve (3).

**NOTE**

DO NOT connect refrigerant fittings using only one wrench. Hold one fitting in place using a wrench and turn other fitting with a second wrench.

- Using wrenches, tighten evaporator coil lines (7) to 216 lb-in (25 Nm).
- Tighten refrigerant lines (4): large hose to compressor to 24 lb-ft (33 Nm); tighten small hose from receiver-dryer to 144 lb-in (16 Nm).
- Evacuate and charge system with refrigerant (WP 0297 00).
- Add refrigerant oil to compressor to replace that which was lost during system discharge (WP 0301 00).

**INSTALLATION - CONTINUED****WARNING**

Refrigerant R-134a air conditioning systems should not be pressure tested or leak tested with compressed air. Combustible mixtures of air and R-134a may form, resulting in a fire or explosion, which could cause personnel injury or death.

10. Leak test air conditioner system (WP 0218 00).
11. Wipe expansion valve (3) and refrigerant line (7) connections clean. Wrap line connections with insulation tape.
12. Wrap expansion valve (3) with strip caulk.
13. Install cover (5) and four screws (6).

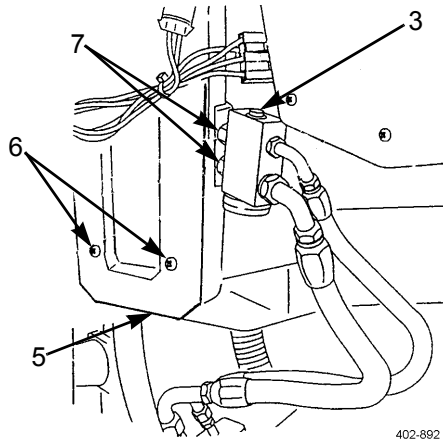

402-892

14. Install cover (2) and nine screws (1).

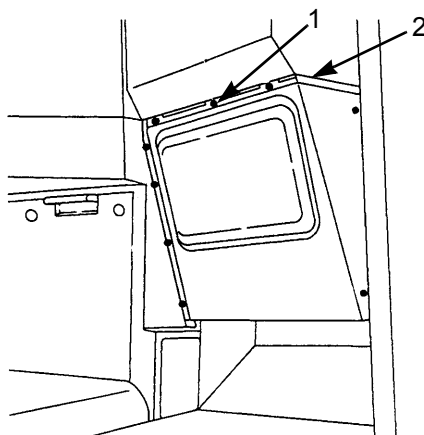

402-891

**END OF WORK PACKAGE**



**THIS WORK PACKAGE COVERS**

General Information, Service

**INITIAL SETUP**

**Maintenance Level**

Direct Support

**Tools and Special Tools**

Tool kit, general mechanic's (Item 102, WP 0313 00)

Gage, oil level (Item 24, WP 0313 00)

Gloves, protective (Item 28, WP 0313 00)

Goggles (Item 30, WP 0313 00)

**Materials/Parts**

Oil, refrigerant (Item 34, WP 0312 00)

Rags, wiping (Item 39, WP 0312 00)

**References**

WP 0218 00

**Equipment Condition**

Refrigerant recovered (WP 0297 00)



**WARNING**



- Use care to prevent refrigerant from touching your skin or eyes. Liquid refrigerant, when exposed to air, quickly evaporates and will freeze skin or eye tissue. Serious injury or blindness may result if you come in contact with liquid refrigerant.
- Refrigerant R-134a air conditioning systems should not be pressure tested or leak tested with compressed air. Combustible mixtures of air and R-134a may form, resulting in a fire or explosion, which could cause personnel injury or death.

**GENERAL INFORMATION**

**CAUTION**

- Always use correct refrigerant oil in R-134a air conditioning system. Never mix oils. If wrong oil is used, or if oils are mixed, compressor could seize due to improper lubrication.
- Refrigerant oil must be from a container that has not been opened or that has been tightly sealed since its last use. Tubing, funnels or other equipment used to transfer refrigerant oil should be very clean and dry. Failure to follow this caution may result in contamination of system.

**NOTE**

Replacing only the amount of refrigerant oil that was removed during evacuation may result in wrong oil charge; oil charge may have been incorrect prior to evacuation. The only way to ensure proper oil charge is to check oil level in compressor with an oil level gage.

1. When handling refrigerant oil:
  - a. Oil should be free of water, dust, metal powder, and other foreign substances.
  - b. DO NOT mix refrigerant oil with other types or viscosities of oil.
  - c. Quickly seal oil container after use. Refrigerant oil absorbs moisture when exposed to air for any period of time.

**GENERAL INFORMATION - CONTINUED**

2. Air conditioning system should have approximately 14 fl oz (414 ml) of refrigerant oil. There should be 10 fl oz (296 ml) in compressor.
3. Each major component has approximately 2 fl oz (59 ml) of refrigerant oil. Therefore, additional oil must be added to compressor when a major component is replaced.

**EXAMPLE:**

If condenser and receiver-dryer are to be replaced, first check oil level in compressor. Compressor should have 10 fl oz (296 ml). Add oil if needed. Then, after replacing condenser and receiver-dryer, add an additional 4 fl oz (118 ml) of oil to compressor. Entire system should then have approximately 14 fl oz (414 ml).

**SERVICE****WARNING**

- DO NOT remove air conditioner compressor oil fill plug without first recovering refrigerant from system. Failure to recover system could cause uncontrolled release of high pressure refrigerant, which can freeze skin and eye tissue causing serious injury or blindness.
  - Use care to prevent refrigerant from touching your skin or eyes. Liquid refrigerant, when exposed to air, quickly evaporates and will freeze skin or eye tissue. Serious injury or blindness may result if you come in contact with liquid refrigerant.
1. Remove oil fill plug (3) and preformed packing (2) from compressor (1). Retain preformed packing if not damaged or if there are no signs of leaks.
  2. Use oil level gage to check oil level in compressor (1).
    - a. If gage bottoms out before going in more than 3 in (7.6 cm), it is hitting compressor crankshaft. Rotate drive plate by hand and insert gage until it contacts bottom of sump.

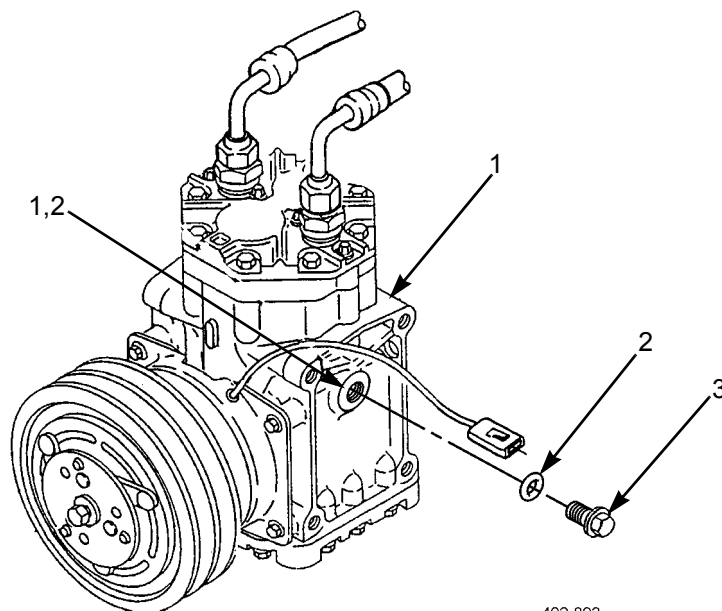

402-893

**SERVICE - CONTINUED**

- b. Use Table 1 to determine oil quantity in compressor (1).

**Table 1. Determination of Compressor Capacity.**

OIL LEVEL GAGE DEPTH IN INCHES (mm)	OIL QUANTITY IN FLUID OZ (ml)
7/8 in (22.2 mm)	6 fl oz (177 ml)
1 in (25.4 mm)	8 fl oz (237 ml)
1 1/8 in (28.6 mm)	10 fl oz (296 ml)
1 7/16 in (36.5 mm)	12 fl oz (355 ml)
1 11/16 in (43 mm)	14 fl oz (414 ml)

3. Add or remove oil from compressor (1) so that oil charge in compressor is 10 fl oz (296 ml).
4. Add additional oil to compressor (1) based on number of air conditioning components replaced. Total charge should be 14 fl oz (414 ml).
5. Ensure preformed packing (2) and threads of oil fill plug (3) are clean. Install preformed packing over threads of oil fill plug being careful not to twist preformed packing.
6. Install oil fill plug (3) and tighten snugly.
7. Charge air conditioning system (WP 0297 00).

**WARNING**

Refrigerant R-134a air conditioning systems should not be pressure tested or leak tested with compressed air. Combustible mixtures of air and R-134a may form, resulting in a fire or explosion, which could cause personnel injury or death.

8. Leak test air conditioning system (WP 0218 00).

**END OF WORK PACKAGE**



**AIR CONDITIONER COMPRESSOR REPLACEMENT****0302 00****THIS WORK PACKAGE COVERS**

Removal, Installation

**INITIAL SETUP****Maintenance Level**

Direct Support

**Tools and Special Tools**

Tool kit, general mechanic's (Item 102, WP 0313 00)

Gloves, protective (Item 28, WP 0313 00)

Goggles (Item 30, WP 0313 00)

**Materials/Parts**

Adhesive, loctite (Item 3, WP 0312 00)

Cap set (Item 8, WP 0312 00)

Oil, refrigerant (Item 34, WP 0312 00)

**Materials/Parts - Continued**

Rags, wiping (Item 39, WP 0312 00)

Tags, marker (Item 42, WP 0312 00)

Packing, preformed (P/N 2-013C557-70) (2)

Washer, lock (P/N AN935-616) (6)

**References**

WP 0218 00

**Equipment Condition**

Alternator belt removed (WP 0059 00)

Refrigerant recovered (WP 0297 00)

AC clutch removed (WP 0217 00)

**WARNING**

- Use care to prevent refrigerant from touching your skin or eyes. Liquid refrigerant, when exposed to air, quickly evaporates and will freeze skin or eye tissue. Serious injury or blindness may result if you come in contact with liquid refrigerant.
- Refrigerant R-134a air conditioning systems should not be pressure tested or leak tested with compressed air. Combustible mixtures of air and R-134a may form, resulting in a fire or explosion, which could cause personnel injury or death.
- DO NOT disconnect refrigerant lines from air conditioner compressor without first recovering refrigerant from system. Failure to recover system could cause uncontrolled release of high pressure refrigerant, which can freeze skin and eye tissue causing serious injury or blindness.

**REMOVAL****NOTE**

If air conditioner compressor is being removed as an equipment condition for engine replacement, DO NOT disconnect refrigerant hoses and lines. Perform ONLY the following four steps:

- Disconnect compressor clutch electrical lead.
- Cut tiedown straps securing refrigerant hoses.
- Remove compressor mounting bolts.
- Move compressor from mounting bracket to truck frame and secure in place to prevent damage.

**REMOVAL - CONTINUED**

1. Disconnect compressor clutch electrical lead (5) from engine harness (6).

**CAUTION**

Water and dirt can damage refrigerant system. Five minutes of not being capped is the limit for any hose or component. DO NOT blow shop air through refrigerant hoses. Shop air is wet (humid).

**NOTE**

DO NOT disconnect refrigerant fittings using only one wrench. Hold one fitting in place using a wrench and turn other fitting with a second wrench.

2. Tag and disconnect two hoses (2) from top of compressor (4).
3. Remove two preformed packings (3) and install protective plugs in hoses (2) and compressor fittings. Discard preformed packings.
4. Loosen two nuts (26) and two jamnuts (11).

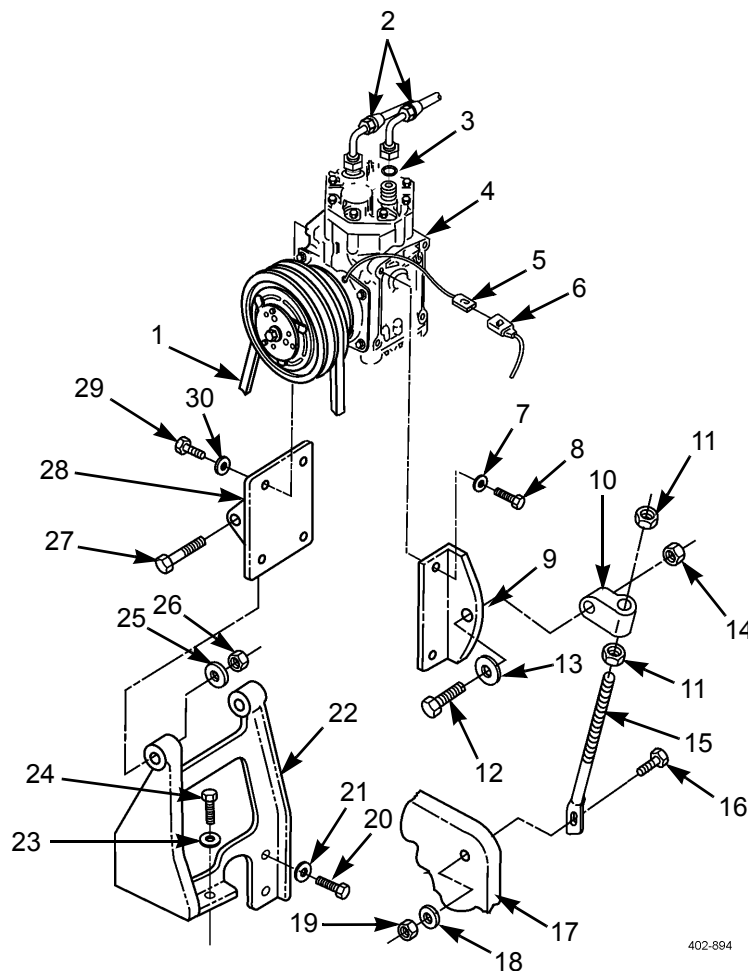

402-894

5. Allow compressor (4) to tilt and remove compressor drive belt (1) from pulley of compressor.

**REMOVAL - CONTINUED**

6. Remove nut (14), screw (12), washer (13), and link end (10) from bracket (9).
7. Remove two jamnuts (11) and link end (10) from adjustment rod (15).
8. Remove nut (19), washer (18), screw (16), and adjustment rod (15) from engine (17).
9. Remove two nuts (26), washers (25), and screws (27) to separate bracket (28) from bracket (22).
10. Remove compressor (4) with brackets (9 and 28) from engine (17).
11. Remove four screws (29), lockwashers (30), and bracket (28) from compressor (4). Discard lockwashers.
12. Remove four screws (8), lockwashers (7), and bracket (9) from compressor (4). Discard lockwashers.
13. Remove screw (24) and washer (23) from bracket (22).
14. Remove two screws (20), washers (21), and bracket (22) from engine (17).

**INSTALLATION**

1. Install bracket (22) to engine (17) with two washers (21) and screws (20).
2. Install washer (23) and screw (24) to bracket (22).
3. Install bracket (9) to compressor (4) with four new lockwashers (7) and screws (8).
4. Install bracket (28) to compressor (4) with four new lockwashers (30) and screws (29).
5. Position compressor (4) to engine (17).
6. Install bracket (22) to bracket (28) with two screws (27), washers (25), and nuts (26). Do not fully tighten nuts.
7. Install adjustment rod (15) to engine (17) with screws (16), washer (18), and nut (19).
8. Install two jamnuts (11) and link end (10) to adjustment rod (15).
9. Install link end (10) to bracket (9) with screw (12), washer (13), and nut (14). Do not fully tighten nut.
10. Position compressor drive belt (1) over compressor (4) pulley.
11. Adjust two jamnuts (11) to tighten compressor belt (1) and tighten jamnuts against link end (10).
12. Tighten two nuts (26) and nut (14).
13. Remove protective plugs from hoses (2) and compressor fittings, install two new preformed packings (3), and lubricate with refrigerant oil.

**NOTE**

DO NOT connect refrigerant fittings using only one wrench. Hold one fitting in place using a wrench and turn other fitting with a second wrench.

14. Apply loctite to threads of compressor (4) fittings and install two hoses (2).
15. Connect compressor clutch electrical lead (5) to engine harness (6).
16. Install and adjust alternator belt (WP 0059 00).
17. Charge air conditioning system (WP 0297 00).

***INSTALLATION - CONTINUED*****WARNING**

Refrigerant R-134a air conditioning systems should not be pressure tested or leak tested with compressed air. Combustible mixtures of air and R-134a may form, resulting in a fire or explosion, which could cause personnel injury or death.

18. Leak test air conditioning system (WP 0218 00).

**END OF WORK PACKAGE**



**AIR CONDITIONER RECEIVER-DRYER REPLACEMENT****0303 00****THIS WORK PACKAGE COVERS**

Removal, Installation

**INITIAL SETUP****Maintenance Level**

Direct Support

**Tools and Special Tools**

Tool kit, general mechanic's (Item 102, WP 0313 00)

Gloves, protective (Item 28, WP 0313 00)

Goggles (Item 30, WP 0313 00)

**Materials/Parts**

Adhesive, loctite (Item 3, WP 0312 00)

Cap set (Item 8, WP 0312 00)

Oil, refrigerant (Item 34, WP 0312 00)

**Materials/Parts - Continued**

Rags, wiping (Item 39, WP 0312 00)

Tags, marker (Item 42, WP 0312 00)

Packing, preformed (P/N J200AR11) (2)

**References**

WP 0218 00

WP 0301 00

WP 0311 00

**Equipment Condition**

Binary switch removed (WP 0215 00)

Refrigerant recovered (WP 0297 00)

Fan cycling switch removed (WP 0216 00)



- Use care to prevent refrigerant from touching your skin or eyes. Liquid refrigerant, when exposed to air, quickly evaporates and will freeze skin or eye tissue. Serious injury or blindness may result if you come in contact with liquid refrigerant.
- Refrigerant R-134a air conditioning systems should not be pressure tested or leak tested with compressed air. Combustible mixtures of air and R-134a may form, resulting in a fire or explosion, which could cause personnel injury or death.

**REMOVAL****CAUTION**

Water and dirt can damage refrigerant system. Five minutes of not being capped is the limit for any hose or component. **DO NOT** blow shop air through refrigerant hoses. Shop air is wet (humid).

**NOTE**

- The receiver-dryer and moisture indicator are one unit and cannot be replaced separately.
- If desiccant cartridge inside receiver-dryer has fallen apart, evacuate system and replace expansion valve and refrigerant compressor (desiccant matter cannot be removed from these parts). A desiccant cartridge may fall apart from too much moisture in system because of poor evacuation of system or lack of maintenance.
- **DO NOT** disconnect or connect refrigerant fittings using only one wrench. Hold one fitting in place using a wrench and turn other fitting with a second wrench.

**REMOVAL - CONTINUED**

1. Tag and disconnect refrigerant lines (1) from receiver-dryer (3). Install plugs in refrigerant lines. Remove and discard preformed packings.
2. Loosen hose clamp (2) attaching receiver-dryer (3) to mounting bracket and remove receiver-dryer.

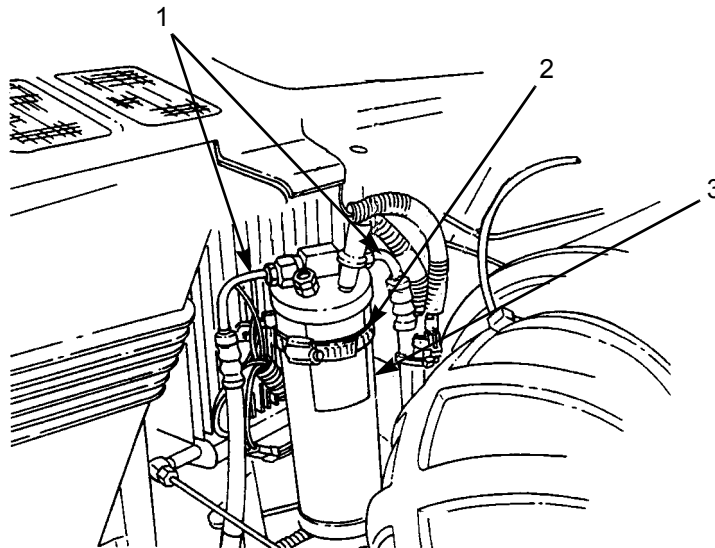

402-895

**INSTALLATION****NOTE**

- Ensure that hose connection ports of new receiver-dryer are securely sealed. If not, receiver-dryer is contaminated with moisture. Do not use.
- Remove tape covering moisture indicator window. The color of the moisture indicator paper inside should be blue, but may be light blue or white if a very small quantity of moisture entered receiver-dryer during manufacture. Proceed with installation. Moisture indicator paper will return to blue color after approximately 30 minutes of system operation.

1. Position receiver-dryer (3) in mounting bracket. Tighten hose clamp (2).
2. Remove plugs from refrigerant lines (1) and line ports on new receiver-dryer (3).
3. Install new preformed packings and apply refrigerant oil to preformed packings.
4. Apply loctite to male fitting threads and connect refrigerant lines (1) to receiver-dryer (3). Apply proper torque in accordance with WP 0311 00.
5. Service air conditioner compressor (WP 0301 00).
6. Install fan cycling switch (WP 0216 00).
7. Install binary switch (WP 0215 00).
8. Charge air conditioning system (WP 0297 00).

**INSTALLATION - CONTINUED****WARNING**

Refrigerant R-134a air conditioning systems should not be pressure tested or leak tested with compressed air. Combustible mixtures of air and R-134a may form, resulting in a fire or explosion, which could cause personnel injury or death.

9. Leak test air conditioning system (WP 0218 00).

**END OF WORK PACKAGE**



**AIR CONDITIONER CONDENSER REPLACEMENT****0304 00****THIS WORK PACKAGE COVERS**

Removal, Installation

**INITIAL SETUP****Maintenance Level**

Direct Support

**Tools and Special Tools**

Tool kit, general mechanic's (Item 102, WP 0313 00)

Crowfoot attachment set (Item 16, WP 0313 00)

Gloves, protective (Item 28, WP 0313 00)

Goggles (Item 30, WP 0313 00)

Wrench, torque, 0-300 lb-in (Item 109, WP 0313 00)

Wrench, torque, 15-75 lb-ft (Item 110, WP 0313 00)

**Materials/Parts**

Adhesive, loctite (Item 3, WP 0312 00)

Cap set (Item 8, WP 0312 00)

Oil, refrigerant (Item 34, WP 0312 00)

Rags, wiping (Item 39, WP 0312 00)

Tags, marker (Item 42, WP 0312 00)

**References**

WP 0218 00

WP 0301 00

WP 0311 00

**Equipment Condition**

Refrigerant recovered (WP 0297 00)

**WARNING**

- Use care to prevent refrigerant from touching your skin or eyes. Liquid refrigerant, when exposed to air, quickly evaporates and will freeze skin or eye tissue. Serious injury or blindness may result if you come in contact with liquid refrigerant.
- Refrigerant R-134a air conditioning systems should not be pressure tested or leak tested with compressed air. Combustible mixtures of air and R-134a may form, resulting in a fire or explosion, which could cause personnel injury or death.

**REMOVAL****CAUTION**

Water and dirt can damage refrigerant system. Five minutes of not being capped is the limit for any hose or component. DO NOT blow shop air through refrigerant hoses. Shop air is wet (humid).

**NOTE**

DO NOT disconnect refrigerant fittings using only one wrench. Hold one fitting in place using a wrench and turn other fitting with a second wrench.

**REMOVAL - CONTINUED**

1. Tag and disconnect refrigerant lines (1) from condenser (2). Install plugs in refrigerant and condenser lines.
2. Remove fasteners attaching condenser (2) to radiator.

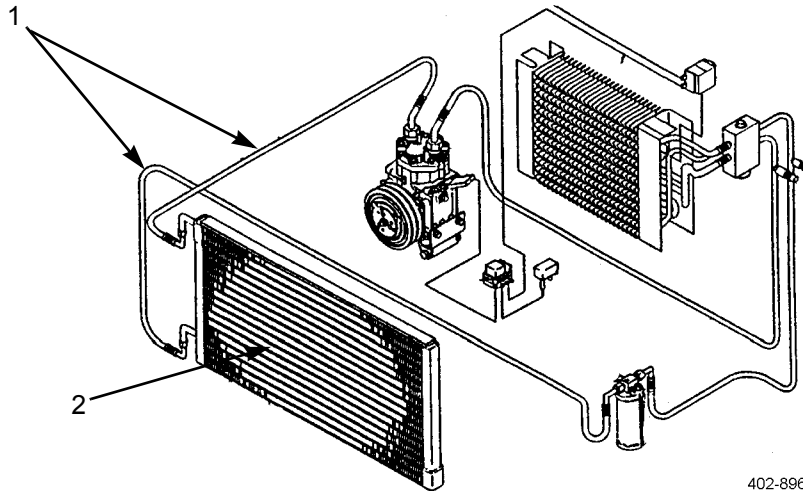

402-896

**INSTALLATION**

1. Position condenser (2) on radiator and install fasteners.
2. Remove plugs from refrigerant lines (1) and line ports on new condenser (2).
3. Install new preformed packings and apply refrigerant oil to preformed packings.
4. Apply loctite to male fitting threads and connect but do not tighten refrigerant lines (1) to condenser (2).

**NOTE**

DO NOT connect refrigerant fittings using only one wrench. Hold one fitting in place using a wrench and turn other fitting with a second wrench.

5. Tighten connections in accordance with WP 0311 00.
6. Service air conditioner compressor (WP 0301 00).
7. Charge air conditioning system (WP 0297 00).

***INSTALLATION - CONTINUED*****WARNING**

Refrigerant R-134a air conditioning systems should not be pressure tested or leak tested with compressed air. Combustible mixtures of air and R-134a may form, resulting in a fire or explosion, which could cause personnel injury or death.

8. Leak test air conditioning system (WP 0218 00).

**END OF WORK PACKAGE**





**AIR CONDITIONER HOSE REPLACEMENT**

**0305 00**

**THIS WORK PACKAGE COVERS**

Removal, Installation

**INITIAL SETUP**

**Maintenance Level**

Direct Support

**Tools and Special Tools**

- Tool kit, general mechanic's (Item 102, WP 0313 00)
- Crowfoot attachment set (Item 16, WP 0313 00)
- Gloves, protective (Item 28, WP 0313 00)
- Goggles (Item 30, WP 0313 00)
- Wrench, torque, 0-300 lb-in (Item 109, WP 0313 00)
- Wrench, torque, 15-75 lb-ft (Item 110, WP 0313 00)

**Materials/Parts**

- Adhesive, loctite (Item 3, WP 0312 00)
- Cap set (Item 8, WP 0312 00)
- Caulk, strip (Item 9, WP 0312 00)
- Oil, refrigerant (Item 34, WP 0312 00)
- Rags, wiping (Item 39, WP 0312 00)

**Materials/Parts - Continued**

- Tape, insulation (Item 42, WP 0312 00)
- Gasket (P/N 22-46774-000)
- Packing, preformed (P/N J200AR11) (as required)
- Packing, preformed (P/N 2-013C557-70) (as required)
- Packing, preformed (P/N 2-015C873-70) (as required)

**References**

- WP 0218 00
- WP 0301 00
- WP 0311 00

**Equipment Condition**

- Refrigerant recovered (WP 0297 00)



- Use care to prevent refrigerant from touching your skin or eyes. Liquid refrigerant, when exposed to air, quickly evaporates and will freeze skin or eye tissue. Serious injury or blindness may result if you come in contact with liquid refrigerant.
- Refrigerant R-134a air conditioning systems should not be pressure tested or leak tested with compressed air. Combustible mixtures of air and R-134a may form, resulting in a fire or explosion, which could cause personnel injury or death.

**REMOVAL**

1. The following air conditioning system hoses can be replaced:
  - a. Compressor-to-tube assembly on firewall
  - b. Compressor-to-condenser
  - c. Receiver-dryer-to-tube assembly on firewall
  - d. Receiver-dryer-to-expansion valve
  - e. Tube assembly (on firewall)-to-expansion valve (2 places)
2. Remove insulation tape from each hose connection.

**NOTE**

DO NOT disconnect or connect refrigerant fittings using only one wrench. Hold one fitting in place using a wrench and turn other fitting with a second wrench.

3. Disconnect each end of hose connection.

**CAUTION**

Water and dirt can damage refrigerant system. Five minutes of not being capped is the limit for any hose or component. DO NOT blow shop air through refrigerant hoses. Shop air is wet (humid).

4. Cap each opening where hose was disconnected.
5. At firewall, remove two screws (2), washers (3), tube assembly (1), and gasket (4). Discard gasket.

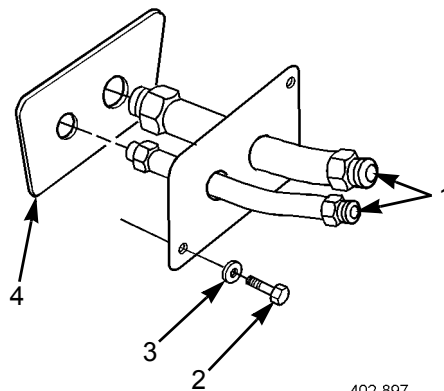
**INSTALLATION**

1. Install gasket (4) on tube assembly (1) and tube assembly on firewall.
2. Install two washers (3) and screws (2).

**INSTALLATION - CONTINUED**

3. Lubricate new preformed packing (5) with refrigerant oil and install.
4. Apply loctite to male threads (6) and connect each end of hose.

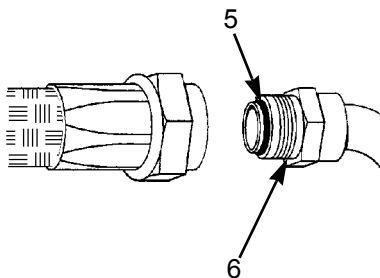

402-898

5. Tighten connections (WP 0311 00).
6. Apply insulation tape at each end of hose connection.
7. Wrap remainder of hose with strip caulk.
8. Service air conditioner compressor (WP 0301 00).
9. Charge air conditioning system (WP 0297 00).

**WARNING**

Refrigerant R-134a air conditioning systems should not be pressure tested or leak tested with compressed air. Combustible mixtures of air and R-134a may form, resulting in a fire or explosion, which could cause personnel injury or death.

10. Leak test air conditioning system (WP 0218 00).

**END OF WORK PACKAGE**



---

**GENERAL MAINTENANCE INSTRUCTIONS****0306 00**

---

**THIS WORK PACKAGE COVERS**

General, Work Safety, Cleaning Instructions, Preservation of Parts, Painting, Inspection Instructions, Disassembly and Assembly Instructions, Repair Instructions, Lubrication Instructions, Application of Adhesives and Sealing Compounds, Standard Tool Requirements, Push-in Air Tube Fittings, Tagging Wires and Hoses, Soldering, Heat Shrinkable Tubing, Electrical Ground Ports, Lines and Ports, Tubes and Compression Fittings, Lockwire, Fluid Disposal, Multimeter, Electrical Repair

---

**INITIAL SETUP****Tools and Special Tools**

Compressor unit (Item 15, WP 0313 00)  
Cutter, tube (Item 17, WP 0313 00)  
Heat gun (Item 33, WP 0313 00)  
Multimeter, digital (Item 60, WP 0313 00)  
Soldering gun (Item 90, WP 0313 00)

**Materials/Parts**

Compound, sealing (Item 17, WP 0312 00)  
Detergent (Item 18, WP 0312 00)  
Flux, soldering (Item 19, WP 0312 00)  
Oil, lubricating (Item 27, WP 0312 00)  
Rags, wiping (Item 39, WP 0312 00)  
Solder, rosin core (Item 40, WP 0312 00)

**Materials/Parts - Continued**

Tags, marker (Item 42, WP 0312 00)  
Tape, duct (Item 44, WP 0312 00)  
Wire, nonelectrical (Item 50, WP 0312 00)

**References**

FM 20-3  
TB 43-0209  
TM 9-214  
TM 9-247  
TM 43-0139  
WP 0098 00  
TM 9-2320-303-10

---

---

**GENERAL MAINTENANCE INSTRUCTIONS - CONTINUED**

---

0306 00

**GENERAL**

1. These general maintenance instructions contain general shop practices and specific methods you must be familiar with to properly maintain both models. You should read and understand these practices and methods before performing any Unit Maintenance procedures.
2. Before beginning a task, find out how much repair, modification or replacement is needed to fix the equipment. Sometimes the reason for equipment failure can be seen right away and complete teardown is not necessary. Disassemble equipment only as far as necessary to repair or replace damaged parts.
3. In some cases, a part may be damaged during removal. If the part appears to be good, and other parts behind it are not defective, leave it in place and continue with the procedure. Here are a few simple rules:
  - a. Do not remove dowel pins or studs unless loose, bent, broken or otherwise damaged.
  - b. Do not remove bearings or bushings unless damaged. If you need to remove them to access parts behind, carefully pull out bearings and bushings.
  - c. Replace all gaskets, lockwashers, locknuts, seals, cotter pins, and preformed packings.
4. All tags and forms attached to the equipment must be checked to learn the reason for removal of equipment from service. Modification Work Orders (MWOs) and Technical Bulletins (TBs) must also be checked for equipment changes and updates.

**WORK SAFETY**

1. Before beginning a procedure, think about the safety risks and hazards to yourself and to others. Wear protective gear such as safety goggles or lenses, safety shoes, rubber apron or gloves.
2. Before beginning a procedure, ensure that the following conditions have been observed, unless otherwise specified:
  - a. Vehicle must be parked on level ground with parking brake applied and wheels blocked.
  - b. Transmission must be in N (Neutral).
  - c. Engine must be off.
  - d. Master battery switch must be in OFF position.
  - e. Components must be at operating temperature to be tested.
3. Immediately clean up spilled fluids to avoid slipping.
4. When lifting heavy parts, have someone help you. Ensure that lifting equipment or jack is working properly, that it meets weight requirement of part being lifted, and that it is securely fastened to part.
5. Always use power tools carefully.
6. Observe all WARNINGS and CAUTIONS.

**CLEANING INSTRUCTIONS****WARNING**

Improper cleaning methods and use of unauthorized cleaning liquids or solvents can injure personnel and damage equipment. To prevent this, refer to TM 9-247 for further instructions.

1. **General.** Cleaning instructions will be the same for the majority of parts and components which make up the truck. The following applies to all cleaning operations:
  - a. Clean all parts before inspection, after repair, and before assembly.
  - b. Keep hands free of grease which can collect dust, dirt, and grit.
  - c. After cleaning, all parts should be covered or wrapped to protect them from dust and dirt. Parts that are subject to rust should be lightly oiled after cleaning.

**CLEANING INSTRUCTIONS - CONTINUED****2. Castings, Forgings, and Machined Metal Parts.**

- a. Clean inner and outer surfaces with detergent and dry with clean rags.
- b. Remove grease and accumulated deposits with a scrub brush.

Compressed air used for cleaning or drying purposes, or for clearing restrictions, should never exceed 30 psi (207 kPa). Wear protective clothing (goggles/shield, gloves, etc.) and use caution to avoid injury to personnel.

- c. Clear all threaded holes with compressed air to remove dirt and cleaning fluids.

**CAUTION**

DO NOT wash oil seals, electrical cables, and flexible hoses with dry cleaning solvent or mineral spirits. Serious damage or destruction of material will result.

3. **Oil Seals, Electrical Cables, and Flexible Hoses.** Wash oil seals, electrical cables, and flexible hoses with a solution of detergent (Item 18, WP 0312 00) and water, and wipe dry with a clean rag.
4. **Bearings.** Clean bearings in accordance with TM 9-214.

**PRESERVATION OF PARTS**

Unpainted metal parts that will not be installed immediately after cleaning may be covered with a thin coat of lubricating oil.

**PAINTING**

1. On painted areas where paint has been removed, paint in accordance with procedures outlined in TM 43-0139 and TB 43-0209.
2. For camouflage painting instructions, refer to FM 20-3.

**INSPECTION INSTRUCTIONS****NOTE**

All damaged areas should be marked for repair or replacement.

1. All components and parts must be carefully checked to determine if they are serviceable for use, can be repaired or must be scrapped.
2. Inspect drilled and tapped (threaded) holes for the following:
  - a. Wear, distortion, cracks, and any other damage in or around holes.
  - b. Threaded areas for wear distortion (stretching) and evidence of cross-threading.
3. Inspect metal lines, flexible lines or hoses, and metal fittings and connectors for the following:
  - a. Metal lines for sharp kinks, cracks, bad bends, and dents.
  - b. Flexible lines or hoses for fraying, evidence of leakage, and loose metal fittings or connectors.
  - c. Metal fittings and connectors for thread damage and worn or rounded hex heads.

***INSPECTION INSTRUCTIONS - CONTINUED***

4. Inspect castings, forgings, and machined metal parts for the following:
  - a. Machined surfaces for nicks, burrs, raised metal wear, and other damage.
  - b. Inner and outer surfaces for breaks and cracks.
5. Inspect bearings in accordance with TM 9-214.

***DISASSEMBLY AND ASSEMBLY INSTRUCTIONS***

1. Keep major components together whenever possible and practical.
2. Tag hoses, electrical wires, cables, and harnesses to identify them and aid during installation.
3. Keep related parts together for identification purposes.
4. Temporarily install attaching hardware such as screws, bolts, washers, and nuts to prevent loss.
5. Only disassemble to the point of the problem.
6. Ensure that parts are clean and lubricated before assembly.

***REPAIR INSTRUCTIONS*****CAUTION**

■ Before welding, the following components must be disconnected: Transmission ECU/TCM, ABS ECU, CWS ECU and batteries. If welding on a trailer, it must be uncoupled from tractor truck. Failure to follow this caution may damage electronic components.

1. Repair castings, forgings, and machined parts using the following instructions:
  - a. Repair minor cracked castings or forgings.
  - b. Repair minor damage to machined surfaces with an abrasive cloth dipped in detergent.
  - c. Replace any deeply nicked machined surface that could affect the assembly operation.
  - d. Repair minor damage to threaded cap screw holes with thread tap of same size to prevent cutting oversize.
2. After repair, thoroughly clean all parts to prevent dirt, metal chips or other foreign material from entering any working parts.

***LUBRICATION INSTRUCTIONS*****NOTE**

Refer to TM 9-2320-303-10 and to Unit PMCS (WP 0024 00) for detailed, illustrated instructions on proper lubrication. Some general practices to remember:

- a. Use the correct lubricant.
- b. Keep lubricants clean.
- c. Clean all fittings prior to lubrication.
- d. Lubricate clean disassembled and new parts to prevent rust.



**APPLICATION OF ADHESIVES AND SEALING COMPOUNDS**

Adhesives and sealing compounds can burn easily, can give off harmful vapors, and are harmful to skin and clothing. To avoid injury or death, keep away from open fire and use in a well-ventilated area. If adhesive or sealing compound contacts skin or clothing, wash immediately with soap and water.

1. **General.** Adhesives are recommended in some tasks to ensure and strengthen seals. Sealing compounds are used to seal parts against moisture. The following information describes their correct use and application.
2. **Adhesive.** Adhesive provides a seal against leakage and a resistance to loosening when used in the assembly of threaded, slip-fitted or press-fitting parts. Always use grade of adhesive specified and never use when other retaining means are provided, such as lockwires, lockwashers, lockplates, and fasteners.
3. **Sealing Compound.**
  - a. Anytime a seal is broken, the part must be thoroughly cleaned to remove any remaining sealing compound and dirt.
  - b. Thoroughly clean surface before applying sealing compound.
  - c. When applying sealing compound, ensure that the area is completely covered. Press sealing compound into and around parts as necessary.
  - d. Sealing compound will set in 15-30 minutes depending on temperature and humidity.

**STANDARD TOOL REQUIREMENTS**

1. The following are general practices regarding the use of tools:
  - a. Always use the proper tool kit and tools for the procedure being performed.
  - b. Ensure that tools are clean and lubricated to reduce wear and to prevent rust.
  - c. Keep track of tools. Do not be careless with them.
  - d. Return tools to toolbox when finished with repair or maintenance.
  - e. Return toolboxes and tools to tool storage when not in use.
  - f. Inventory tools before and after each use.
2. Some maintenance tasks may require special or fabricated tools. The "Initial Setup" of the procedure will specify any special or fabricated tools needed to perform that procedure. Use these special tools only for the maintenance procedures for which they are designed or called out. If you are unfamiliar with a required tool, see your supervisor.

**PUSH-IN AIR TUBE FITTINGS****NOTE**

Some air tubes use conventional compression fittings with tube nuts. Other air tubes use plastic push-in fittings. The following procedure applies to push-in fitting replacement.

1. **Removal.**
  - a. Press release button, hold release button against fitting body, then pull air tube out from push-in fitting.
  - b. To remove push-in fitting, loosen jamnut and remove fitting from component.
  - c. Repeat steps 1 and 2 at other end of air tube.

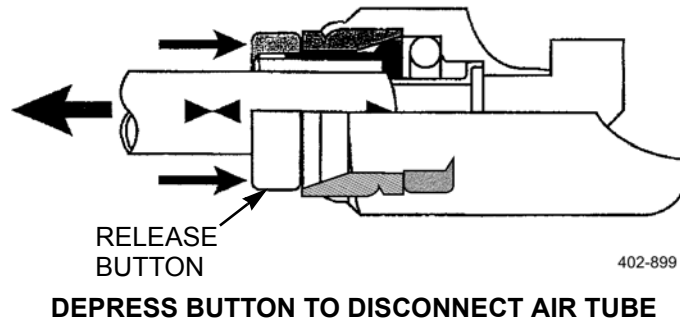
**PUSH-IN AIR TUBE FITTINGS - CONTINUED**2. **Installation.****NOTE**

Ensure push-in fittings are clean and dry before they are installed.

- a. Apply a thin coat of pipe sealing compound to any male threads of push-in fitting. Install push-in fitting to component. Tighten jamnut.

**CAUTION**

DO NOT cut new air tube shorter than damaged air tube. It is permissible to cut new air tube slightly longer than damaged air tube.

**NOTE**

- Cut new air tube squarely. A maximum 15-degree angle is permissible. If using Parker premarked tubing, cut should be in center of "bowtie" symbol.
  - Perform step b if fabricating a new tube.
- b. Compare length of damaged air tube to bulk air tube and cut new air tube to same length. Cut tubing squarely. For best results, use tube cutter.

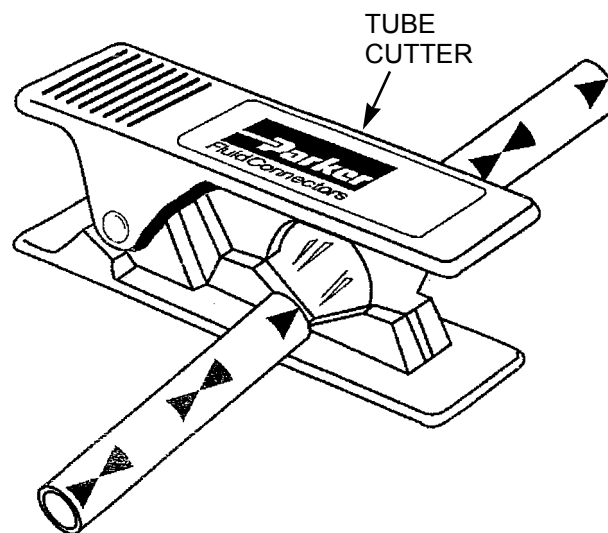

**PUSH-IN AIR TUBE FITTINGS - CONTINUED**

- c. Position new air tube to vehicle. Check that port or mating part is clean and free of debris.

**NOTE**

Perform steps d and e at each end of air tube.

- d. Insert air tube into push-in fitting until it bottoms. Push twice to ensure that air tube is inserted past collet and o-ring.
- e. Confirm that air tube is fully installed to push-in fitting by pulling on air tube. Air tube should not pull out of push-in fitting.

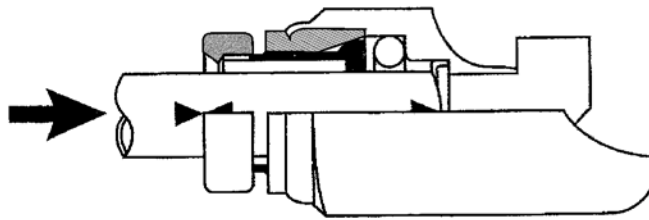

402-901

**INSERT AIR TUBE UNTIL IT BOTTOMS****TAGGING WIRES AND HOSES**

1. Use marker tags to identify all electrical wires, fuel, oil, air, and coolant lines, and any other parts which may be hard to identify or replace later. Fasten tags to parts during removal by wrapping wire fasteners around or through parts and twisting ends together. Position tags to be out of the way during cleaning, inspection, and repair. Mark tags with a pencil, pen or marker.
2. Whenever possible, identify electrical wires with the number of the terminal or wire to which it connects. If no markings can be found, tag both wires or wire and terminal, and use the same identifying mark for both. If you cannot tag a wire because it must fit through a small hole or you cannot reach it, write down the description of the wire and the point to which it connects or draw a simple diagram on paper. Be sure to write down enough information so you will be able to properly connect the wires during assembly. If you need to identify a loose wire, look for identifying number near end of the wire, stamped on a permanent metal tag. Compare the number to wire numbers on the appropriate electrical schematic.
3. Identify fuel, oil, and coolant lines when you are taking off more than one line at the same time. Mark tags with points to which lines and hoses must be connected. If it is not obvious which end of a line goes where, tag each end of the line.
4. Identify and tag other parts as required by name and installed location.

**SOLDERING****CAUTION**

Use low wattage soldering gun when soldering electrical wires, connectors, terminal lugs, and receptacles. High wattage soldering guns may damage parts by overheating.

**SOLDERING - CONTINUED**

1. Solder connection must be bright and clean before soldering. Remove dirt and grease with detergent. Solder used must be of lead-tin alloy, rosin core with soldering flux. All wires, parts, and soldering gun must be tinned for good connection and maximum transfer of heat.
2. To prevent overheating damage to electrical parts when soldering and unsoldering connections, hold bare wire, lead or terminal lug close to soldering point with long roundnose pliers. Pliers act as heat sink and absorb excess heat.
3. Clean all solder joints with a scrub brush and electrical parts with detergent after soldering to get a bright, clean surface.

**HEAT SHRINKABLE TUBING****NOTE**

Further information on shrink wrap usage and sources of supply can be found in WP 0098 00.

Use heat shrinkable tubing to insulate soldered and crimped electrical connections as follows:

- a. Cut desired length of new heat shrinkable tubing twice the diameter of the connection to be covered.
- b. Slide the heat shrinkable tubing onto the wire and out of the way before making electrical connection.
- c. After making electrical connection, slide heat shrinkable tubing into place over electrical connection.

DO NOT touch heat shrinkable tubing for at least 30 seconds after heating. Heat shrinkable tubing is hot and will burn you.

- d. Hold heat gun 4-5 in (10.2-12.7 cm) away from heat shrinkable tubing and apply heat for approximately 30 seconds. Stop applying heat as soon as heat shrinkable tubing forms to the shape of the electrical connection.

**ELECTRICAL GROUND POINTS**

Many electrical problems are the result of poor ground connections. You can ensure that ground connections are good by performing the following steps:

**WARNING**

Although master battery switch must be on and battery ground cable connected in order to test electrical circuit voltage, turn off master battery switch or disconnect battery ground cable before performing resistance tests or replacing parts. This will prevent shock to personnel, and damage to parts and equipment.

- a. Remove hardware connecting ground cable terminal lug to ground point.
- b. Clean mounting hardware, ground cable terminal lugs, and ground point with detergent and scrub brush.
- c. Remove any rust with wire brush and crocus cloth.
- d. Look for cracks, loose terminal lugs, and stripped threads. Replace any defective parts.
- e. Install hardware connecting ground cable terminal lug to ground point. Ensure that all hardware is tight.

**LINES AND PORTS**

To keep dirt from contaminating fluid systems when removing and installing fuel, oil, and coolant lines, perform the following steps:

- a. Clean fittings and surrounding area before disconnecting lines.
- b. Cover, cap, plug or tape lines and ports after disconnecting lines. When these are not available, use hand-carved wooden plugs, clean rags, duct tape or other similar materials to prevent dirt from entering system.
- c. Ensure that new and used parts are clean before installing.
- d. Wait to remove cover, cap, plug or tape from lines and ports until just before installing lines.

**TUBES AND COMPRESSION FITTINGS**

1. Tubes with inverted nuts and compression fittings are designed for one time assembly. Once assembled, they must be replaced as a unit if any parts are found defective. Used parts may not seal properly when used with new ones.
2. Used tube assemblies in good condition can be installed to their original location without leaking.
3. Assemble new tubes, compression sleeves, and inverted nuts as follows:
  - a. Slide inverted nut onto end of tube.
  - b. Slide compression sleeve onto end of tube.
  - c. Repeat previous two steps for other end of tube as required.

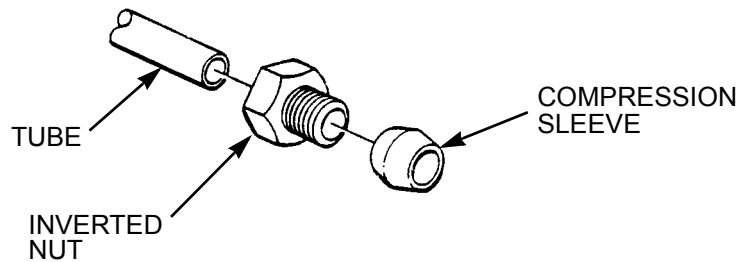

402-902

4. Install new tube assemblies as follows:
  - a. Insert end of tube as far as it will go into compression fitting to which tube is being installed.
  - b. Twist inverted nut into compression fitting and tighten inverted nut against compression sleeve with open-end wrench. Compression sleeve will clamp down around tube and conform to internal surface of compression fitting and inverted nut.
  - c. Repeat previous two steps for other end of tube as required.

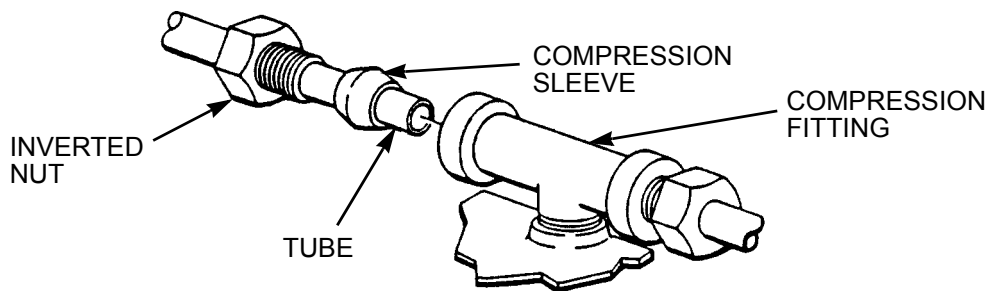

402-903

**LOCKWIRE**

1. Always use nonelectrical wire.
2. Drilled head screws and bolts usually do not require lockwiring if they are installed with self-locking nuts or lockwashers.
3. Three screws or bolts are the maximum number that may be lockwired in a series when they are spaced 4-6 in (10.2-15.2 cm) apart. The maximum number of closely spaced multiple groups of screws or bolts to be lockwired is limited to the number of units that can be lockwired with a 24 in (61 cm) length of wire.
4. Do not secure screws, bolts or fittings which are spaced more than 6 in (15.2 cm) apart. Lockwire these fasteners to tie points 6 in (15.2 cm) or less away.
5. Lockwire parts so that tension will be on lockwire when parts tend to loosen. Lockwire should be installed and twisted tight so that loop around head stays down and does not come up over head of screw or bolt. This does not apply to castellated nuts when slot is close to top of nuts; wire is more secure when made to pass along the side of stud. Ensure that lockwire is tight but not overstressed.
6. Make pigtail of 1/4-1/2 in (6.4-12.7 mm) at end of lockwire. Bend pigtail down so it will not become a snag.
7. When lockwiring castellated nuts, tighten castellated nut to low side of torque range, then continue tightening until slot lines up with hole.
8. In blind, tapped hole application of bolts, castellated nuts or studs, lockwire as illustrated.

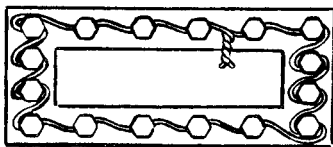

SMALL SCREWS IN CLOSELY SPACED, CLOSED GEOMETRICAL PATTERN: SINGLE WIRE METHOD

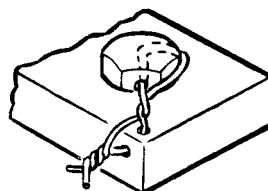

SINGLE FASTENER APPLICATION: DOUBLE TWIST METHOD

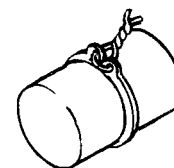

EXTERNAL RETAINER RING: SINGLE WIRE METHOD

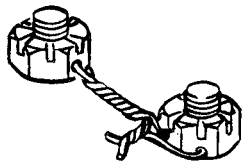

CASTELLATED NUTS ON UNDRILLED STUDS: DOUBLE TWIST METHOD

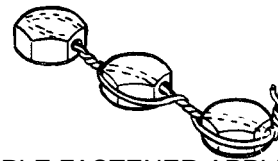

MULTIPLE FASTENER APPLICATION: DOUBLE TWIST METHOD

402-904

**FLUID DISPOSAL**

Dispose of contaminated drained fluids in accordance with the Standard Operating Procedures (SOP) of your unit.

**MULTIMETER**

1. General. The digital multimeter is used to troubleshoot the electrical system of the vehicle. The multimeter's ohms scale is used to test for continuity, shorts, and resistance and the voltmeter scale is used to test voltage levels at any point in the electrical system.

**MULTIMETER - CONTINUED**

2. Continuity Tests. Continuity tests are performed to check for breaks in a circuit (such as a fuse, switch, light bulb or electrical cable).

**NOTE**

If digital readout will not zero properly, replace batteries and repeat zeroing procedure. If digital readout will not zero after batteries have been replaced, notify your supervisor.

a. **Zero the Multimeter.**

- (1) Set multimeter ON/OFF switch (1) to ON position.
- (2) Press OHMS FUNCTION switch (2).
- (3) Press LOWEST VOLTAGE/OHMS selector switch (3).
- (4) Touch black and red probes (4 and 5) together and check for a zero reading on digital readout (6).

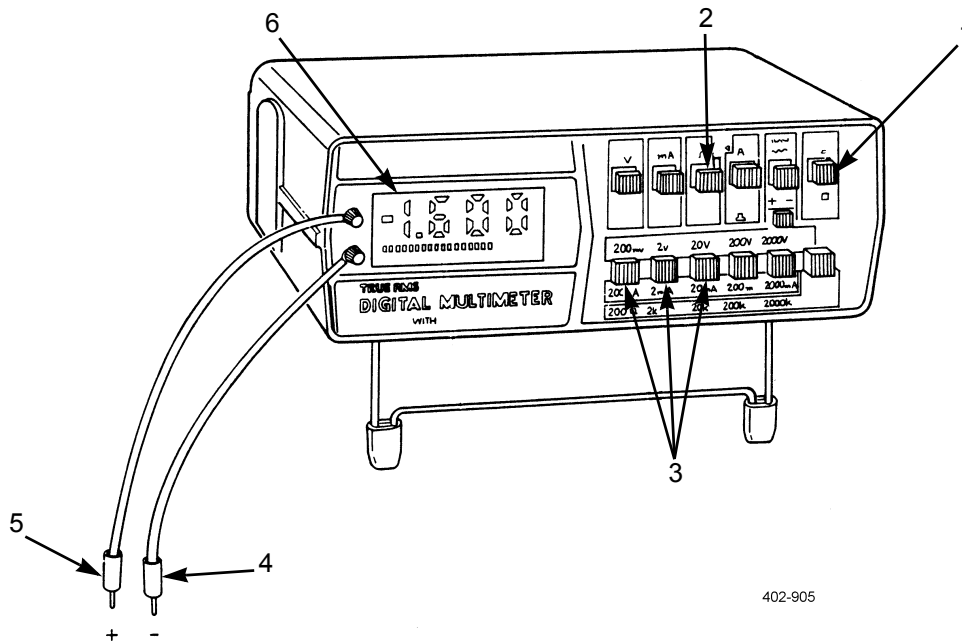

402-905

**CAUTION**

Before performing a continuity test, always turn master battery switch to OFF position and disconnect circuit to be tested. Failure to follow this caution may damage multimeter.

b. **Testing for Continuity.**

- (1) Zero multimeter.
- (2) Connect black and red probes (4 and 5) to both terminals of circuit being tested.
- (3) Read digital readout (6) and interpret results as follows:
  - (a) If digital readout (6) indicates 0 (zero), circuit has continuity.
  - (b) If digital readout (6) indicates resistance, circuit is open.

MULTIMETER - CONTINUED

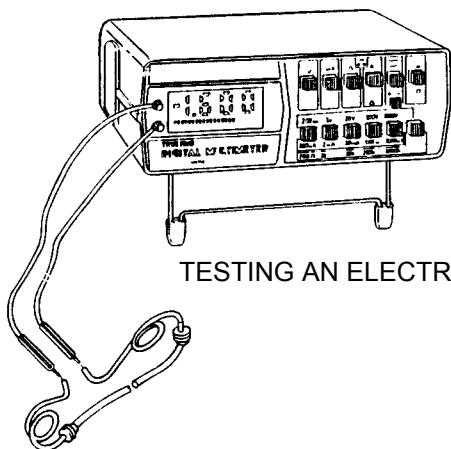

TESTING AN ELECTRICAL CABLE

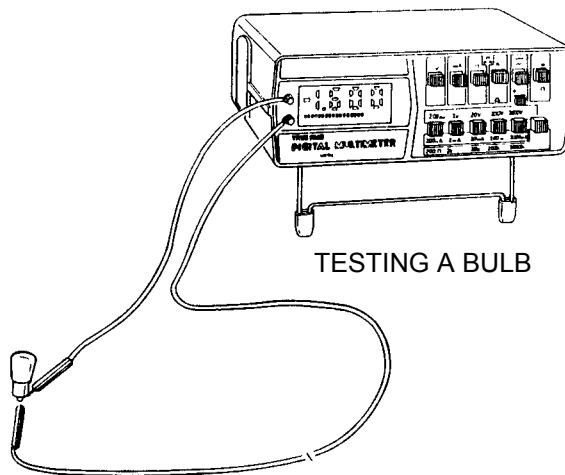

TESTING A BULB

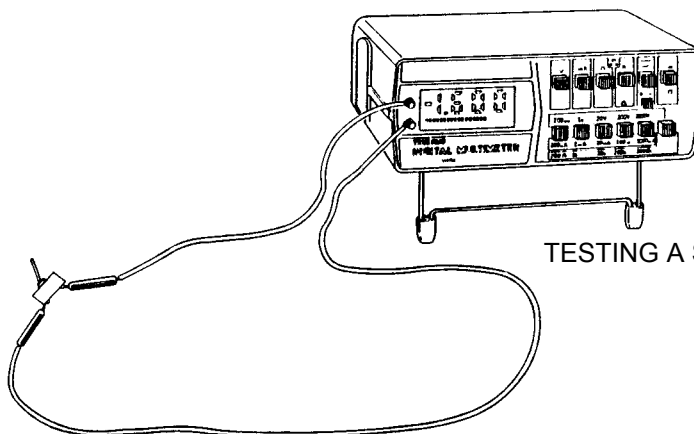

TESTING A SWITCH

402-906

**CAUTION**

Before performing a continuity test, always turn master battery switch to OFF position and disconnect circuit to be tested. Failure to follow this caution may damage multimeter.

- c. Testing for Shorts. A short (or short circuit) occurs when two circuits that should not be connected have metal-to-metal contact with each other. A short also occurs when a circuit that should not touch ground has metal-to-metal contact with ground.

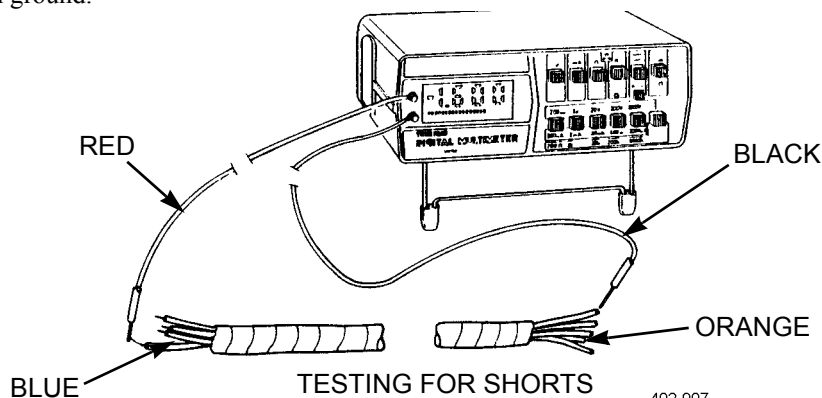

TESTING FOR SHORTS

402-907



**MULTIMETER - CONTINUED**

- (1) Zero multimeter.
- (2) Connect black probe (4) to one circuit and red probe (5) to either a ground or another circuit.
- (3) Read digital readout (6) and interpret results as follows:
  - (a) If digital readout (6) indicates 0 (zero), circuits are shorted or circuit is grounded if testing to ground.
  - (b) If digital readout (6) does not indicate 0 (zero), circuits are not shorted.
  - (c) If digital readout (6) jumps or flickers, circuits are shorted or grounded intermittently.

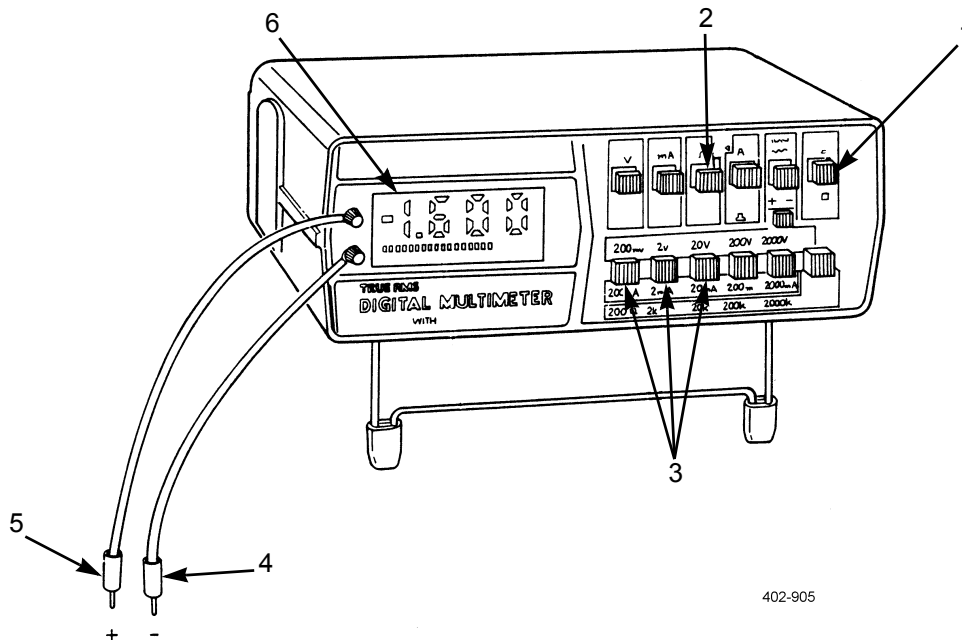

402-905

**CAUTION**

Before performing a continuity test, always turn master battery switch to OFF position and disconnect circuit to be tested. Failure to follow this caution may damage multimeter.

- d. Testing for Resistance. Allowable resistance readings depend on circuit being tested. Refer to the particular section dealing with that circuit or component for allowable readings.
  - (1) Zero multimeter.
  - (2) Press OHMS FUNCTION switch (2).
  - (3) Press LOWEST VOLTAGE/OHMS selector switch (3). If test calls for ohms range other than RX1, set RANGE SELECTOR switch (7) to required range.
  - (4) Connect black and red probes (4 and 5) across circuit to be tested.
  - (5) Read digital readout (6) and interpret results as circuit resistance.

3. **Measuring DC Voltage.**

- a. Set multimeter ON/OFF switch (1) to ON position.
- b. Press VOLTS FUNCTION switch (8).
- c. Set AC/DC selector switch (9) to DC.

**MULTIMETER - CONTINUED**

- d. Select and press LOWEST VOLTAGE/OHMS selector switch (3) for voltage range higher than volts to be measured.
- e. Connect red probe (5) to positive (+) side of circuit and black probe (4) to negative (-) side of circuit.
- f. Read digital readout (6) and interpret results as DC voltage in circuit being tested.

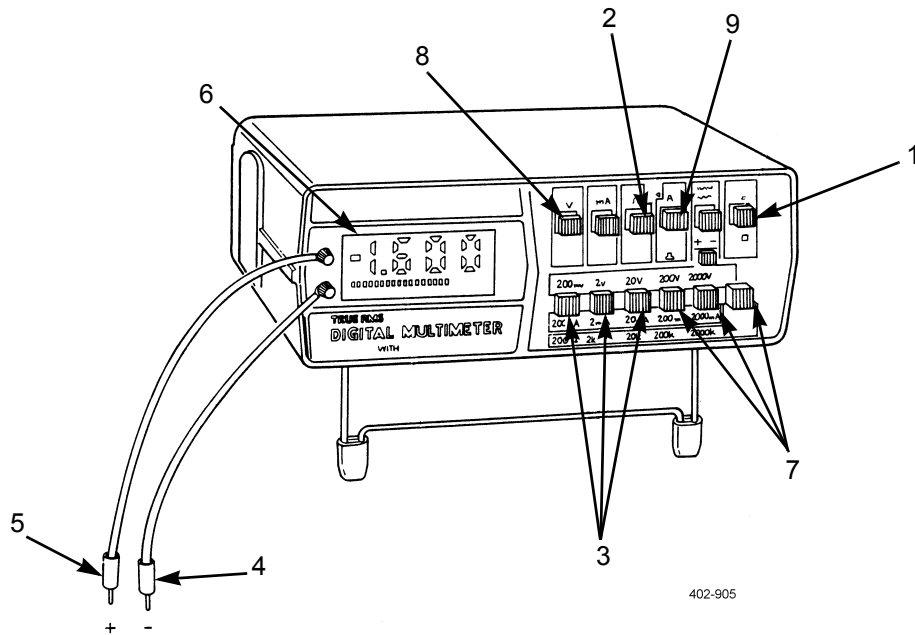

402-905

**ELECTRICAL REPAIR**

For complete instructions on the repair of standard military and commercial connectors and general information on splicing, refer to WP 0099 00.

**END OF WORK PACKAGE**

**CHAPTER 5**  
**SUPPORTING INFORMATION**



**REFERENCES**

**0307 00**

**SCOPE**

This work package lists all forms, field manuals, technical bulletins, technical manuals, and other publications referenced in this manual and which apply to Unit, Direct Support, and General Support Maintenance for both models.

**PUBLICATIONS INDEXES**

The following indexes should be consulted frequently for latest changes or revisions and for new publications relating to material covered in this technical manual.

Consolidated Index of Army Publications and Blank Forms . . . . . DA Pam 25-30  
 Functional User’s Manual for the Army Maintenance Management System . . . . . DA Pam 750-8  
 U.S. Army Equipment Index of Modification Work Orders . . . . . DA Pam 750-10

**FORMS**

Refer to DA Pam 750-8, *The Army Maintenance Management System (TAMMS)*, for instructions on the use of maintenance forms.

Equipment Inspection and Maintenance Worksheet . . . . . DA Form 2404, DA Form 5988-E  
 Equipment Log Assembly (Records) . . . . . DA Form 2408  
 Maintenance Request Form . . . . . DA Form 2407  
 Preventive Maintenance Schedule and Record . . . . . DD Form 314  
 Processing and Deprocessing Record for Shipment, Storage and Issue of Vehicles and Spare Engines . . . . . DD Form 1397  
 Product Quality Deficiency Report . . . . . SF Form 368  
 Recommended Changes to Publications and Blank Forms . . . . . DA Form 2028  
 Report of Discrepancy (ROD) . . . . . SF Form 364

**FIELD MANUALS**

Camouflage . . . . . FM 20-3  
 First Aid Manual . . . . . FM 4-25.11  
 Metal Body Repair and Related Operations . . . . . TC 9-510  
 Operation and Maintenance of Ordnance Material in Extreme Cold Weather (0°F to -65°F) . . . . . FM 9-207  
 Rigging . . . . . FM 5-125

**TECHNICAL BULLETINS AND SUPPLY BULLETINS**

Color, Marking, and Camouflage Painting of Military Vehicles, Construction Equipment,  
 and Materials Handling Equipment . . . . . TB 43-0209  
 Corrosion Prevention and Control Including Rustproofing Procedures for Tactical Vehicles and Trailers . . . . . TB 43-0213  
 Use of Antifreeze Solutions and Cleaning Compounds in Engine Cooling Systems . . . . . TB 750-651  
 Solder and Soldering . . . . . TB SIG 222

**REFERENCES - CONTINUED**

**0307 00**

**TECHNICAL MANUALS**

Administrative Storage of Equipment . . . . . TM 740-90-1

Cooling Systems: Tactical Vehicles . . . . . TM 750-254

Engine, Diesel: 6 Cylinder In-line, Turbocharged Cummins Model NTC-400 . . . . . TM 9-2815-225-34&P

Inspection, Care, and Maintenance of Antifriction Bearings . . . . . TM 9-214

Materials Used for Cleaning, Preserving, Abrading and Cementing Ordnance  
 Materiel and Related Materials, Including Chemicals. . . . . TM 9-247

Operator's and Organizational Maintenance Manual Including Repair  
 Parts and Special Tool List for Decontaminating Apparatus, Portable . . . . . TM 3-4230-214-12&P

Operator's, Unit, Direct Support and General Maintenance Manual for  
 Care, Maintenance, Repair and Inspection of Pneumatic Tires and Inner Tubes . . . . . TM 9-2610-200-14

Operator's, Organizational, Direct Support, and General Support Maintenance  
 Manual for Lead-acid Storage Batteries . . . . . TM 9-6140-200-14

Operator's Manual for M915A4 . . . . . TM 9-2320-303-10

Operator's, Unit, Direct Support Maintenance Manual with RPSTL for M917A2  
 and M917A2 w/MCS Dump Truck Body . . . . . TM 5-3805-264-14&P

Painting Instruction for Field Use . . . . . TM 43-0139

Preservation, Packaging, and Packing of Military Supplies and Equipment . . . . . TM 38-230-1 & TM 38-230-2

Procedures for Destruction of Tank-automotive Equipment to Prevent Enemy Use . . . . . TM 750-244-6

Repair Parts and Special Tools Lists for M915A4 . . . . . TM 9-2320-303-24P

Use of Antifreeze Solutions, Antifreeze Extender, Cleaning Compounds, and  
 Test Kit in Engine Cooling Systems . . . . . TM 750-651

**OTHER PUBLICATIONS**

Abbreviations and Acronyms . . . . . ASME Y14.38-1999

Allison Transmission:

    Operator's Manual . . . . . SA2157J

    Parts Catalog. . . . . SA2456B

    Principles of Operation. . . . . SA2454B

    Service Manual. . . . . SA2457B

    Troubleshooting Manual. . . . . SA2973

Army Medical Department Expendable/Durable Items . . . . . CTA 8-100

Expendable/Durable Items (Except Medical, Class V Repair Parts, and Heraldic Items. . . . . CTA 50-970

Fuels and Lubricants Standardization Policy for Equipment Design, Operation, and Logistic Support . . . . . AR 70-12

Vehicle, Wheeled, Preparation for Shipment and Limited Storage of . . . . . MIL-V-62038E

**END OF WORK PACKAGE**

**THE ARMY MAINTENANCE SYSTEM MAC**

1. This introduction provides a general explanation of all maintenance and repair functions authorized at the two maintenance levels under the Two-Level Maintenance System concept.
2. The MAC immediately following the introduction designates overall authority and responsibility for the performance of maintenance functions on the identified end item or component. The application of the maintenance functions to the end item or component shall be consistent with the capacities and capabilities of the designated maintenance levels, which are shown in the MAC (WP 0309 00) in column (4) as:

Field - includes subcolumns:

- C - Operator/Crew
- O - Unit
- F - Direct Support

Sustainment - includes subcolumns:

- H - General Support
- D - Depot

3. The tools and test equipment requirements (immediately following the MAC) list the tools and test equipment (both special tools and common tool sets) required for each maintenance function as referenced from the MAC.
4. The remarks (immediately following the tools and test equipment requirements) contain supplemental instructions and explanatory notes for a particular maintenance function.

**MAINTENANCE FUNCTIONS**

Maintenance functions are limited to and defined as follows:

1. **Inspect.** To determine the serviceability of an item by comparing its physical, mechanical, and/or electrical characteristics with established standards through examination (e.g., by sight, sound, or feel).
2. **Test.** To verify serviceability by measuring the mechanical, pneumatic, hydraulic or electrical characteristics of an item and comparing those characteristics with prescribed standards on a scheduled basis, i.e., load testing of lift devices and hydrostatic testing of pressure hoses.
3. **Service.** Operations required periodically to keep an item in proper operating condition; e.g., to clean (includes decontaminate, when required), to preserve, to drain, to paint or to replenish fuel, lubricants, chemical fluids or gases.
4. **Adjust.** To maintain or regulate, within prescribed limits, by bringing into proper position, or by setting the operating characteristics to specified parameters.
5. **Align.** To adjust specified variable elements of an item to bring about optimum or desired performance.
6. **Calibrate.** To determine and cause corrections to be made or to be adjusted on instruments of test, measuring, and diagnostic equipment used in precision measurement. Consists of comparisons of two instruments, one of which is a certified standard of known accuracy, to detect and adjust any discrepancy in the accuracy of the instrument being compared.
7. **Remove/Install.** To remove and install the same item when required to perform service or other maintenance functions. Install may be the act of emplacing, seating or fixing into position a spare, repair part or module (component or assembly) in a manner to allow the proper functioning of an equipment or system.
8. **Replace.** To remove an unserviceable item and install a serviceable counterpart in its place. "Replace" is authorized by the MAC and its assigned maintenance level is shown as the third position code of the Source, Maintenance and Recoverability (SMR) code.
9. **Repair.** The application of maintenance services, including fault location/troubleshooting, removal/installation, disassembly/assembly procedures, and maintenance actions to identify troubles and restore serviceability to an item by correcting specific damage, fault, malfunction or failure in a part, subassembly, module (component or assembly), end item or system.

**MAINTENANCE FUNCTIONS - CONTINUED****NOTE**

The following definitions are applicable to the "repair" maintenance function:

- Services - Inspect, test, service, adjust, align, calibrate, and/or replace.
  - Fault location/troubleshooting - The process of investigating and detecting the cause of equipment malfunctioning; the act of isolating a fault within a system or Unit Under Test (UUT).
  - Disassembly/assembly - The step-by-step breakdown (taking apart) of a spare/functional group coded item to the level of its least component, that is assigned an SMR code for the level of maintenance under consideration (i.e., identified as maintenance significant).
  - Actions - Welding, grinding, riveting, straightening, facing, machining, and/or resurfacing.
10. **Overhaul.** That maintenance effort (service/action) prescribed to restore an item to a completely serviceable/operational condition as required by maintenance standards in appropriate technical publications. Overhaul is normally the highest degree of maintenance performed by the Army. Overhaul does not normally return an item to like new condition.
11. **Rebuild.** Consists of those services/actions necessary for the restoration of unserviceable equipment to a like new condition in accordance with original manufacturing standards. Rebuild is the highest degree of materiel maintenance applied to Army equipment. The rebuild operation includes the act of returning to zero those age measurements (hours/miles, etc.) considered in classifying Army equipment/components.

**EXPLANATION OF COLUMNS IN THE MAC, TABLE 1**

1. **Column (1) - Group Number.** Column (1) lists FGC numbers, the purpose of which is to identify maintenance significant components, assemblies, subassemblies, and modules with the Next Higher Assembly (NHA).
2. **Column (2) - Component/Assembly.** Column (2) contains the item names of components, assemblies, subassemblies, and modules for which maintenance is authorized.
3. **Column (3) - Maintenance Function.** Column (3) lists the functions to be performed on the item listed in Column (2). (For a detailed explanation of these functions refer to "Maintenance Functions" outlined above).
4. **Column (4) - Maintenance Level.** Column (4) specifies each level of maintenance authorized to perform each function listed in column (3), by indicating work time required (expressed as manhours in whole hours or decimals) in the appropriate subcolumn. This work time figure represents the active time required to perform that maintenance function at the indicated level of maintenance. If the number or complexity of the tasks within the listed maintenance function varies at different maintenance levels, appropriate work time figures are to be shown for each level. The work time figure represents the average time required to restore an item (assembly, subassembly, component, module, end item or system) to a serviceable condition under typical field operating conditions. This time includes preparation time (including any necessary disassembly/assembly time), troubleshooting/fault location time, and quality assurance time in addition to the time required to perform the specific tasks identified for the maintenance functions authorized in the MAC. The symbol designations for the various maintenance levels are as follows:

Field - includes subcolumns:

- C - Operator/Crew
- O - Unit
- F - Direct Support

Sustainment - includes subcolumns:

- H - General Support
- D - Depot



**EXPLANATION OF COLUMNS IN THE MAC, TABLE 1 - CONTINUED****NOTE**

The "L" maintenance level is not included in column (4) of the MAC. Functions to this level of maintenance are identified by a work time figure in the "H" column of column (4), and an associated reference code is used in the REMARKS CODE column (6). This code is keyed to the remarks and the SRA complete repair application is explained there.

5. **Column (5) - Tools and Equipment Reference Code.** Column (5) specifies, by code, those common tool sets (not individual tools), common Test, Measurement and Diagnostic Equipment (TMDE), and special tools, special TMDE, and special support equipment required to perform the designated function. Codes are keyed to the entries in the tools and test equipment table.
6. **Column (6) - Remarks Code.** When applicable, this column contains a letter code, in alphabetical order, which is keyed to the remarks table entries (Table 3).

**EXPLANATION OF COLUMNS IN THE TOOLS AND TEST EQUIPMENT REQUIREMENTS, TABLE 2**

1. **Column (1) - Tool or Test Equipment Reference Code.** The tool and test equipment reference code correlates with a code used in column (5) of the MAC.
2. **Column (2) - Maintenance Level.** The lowest level of maintenance authorized to use the tool or test equipment.
3. **Column (3) - Nomenclature.** Name or identification of the tool or test equipment.
4. **Column (4) - National Stock Number (NSN).** The NSN of the tool or test equipment.
5. **Column (5) - Tool Number.** The manufacturer's part number, model number or type number.

**EXPLANATION OF COLUMNS IN THE REMARKS, TABLE 3**

1. **Column (1) - Remarks Code.** The code recorded in column (6) of the MAC.
2. **Column (2) - Remarks.** This column lists information pertinent to the maintenance function being performed as indicated in the MAC.

**END OF WORK PACKAGE**



**MAINTENANCE ALLOCATION CHART (MAC)**

**0309 00**

**Table 1. MAC for the Glider Family of Vehicles.**

(1)  Group Number	(2)  Component/ Assembly	(3)  Maintenance Function	(4) Maintenance Level				(5)  Tools and Equipment REF CODE	(6)  Remarks Code	
			FIELD		SUSTAINMENT				
			Unit		DS	GS			Depot
			C	O	F	H			D
<b>01</b>	<b>ENGINE</b>						E		
<b>03</b>	<b>FUEL SYSTEM</b>								
0301	Fuel Injector Assembly	Replace			2.0		54,75		
		Repair			1.8		54,75		
0302	Fuel Pump	Replace			0.5		75		
0304	Air Cleaner Assembly	Replace		0.3			75		
	Air Intake Assembly	Replace		0.2			75		
0305	Turbocharger	Replace			0.8		2,53,54,75		
		Repair				3.0	54,75		
0306	Tanks, Lines, Fittings, Headers								
	Fuel Tank	Inspect	0.1	0.1					
		Replace		2.0			56,75		
	Fuel Hoses, Lines, and Fittings	Replace		0.5			74		
0309	Fuel Filter Elements	Service	0.1						
		Replace		0.3			56		
0311	Engine Starting Aids								
	Ether Starting Aid	Inspect	0.1						
		Replace		1.0			75		
		Repair		0.5			75		
		Service		0.5			75		
<b>04</b>	<b>EXHAUST SYSTEM</b>								
0401	Muffler and Pipes								
	Muffler	Inspect	0.1	0.1					
		Replace		0.5			75		
	Exhaust Pipe	Inspect	0.1	0.1					
		Replace		1.3			75		

Table 1. MAC for the Glider Family of Vehicles - Continued.

(1) Group Number	(2) Component/ Assembly	(3) Maintenance Function	(4) Maintenance Level				(5) Tools and Equipment REF CODE	(6) Remarks Code	
			FIELD		SUSTAINMENT				
			Unit		DS	GS			Depot
			C	O	F	H			D
<b>05</b>	<b>COOLING SYSTEM</b>								
0501	Radiator Assembly	Service Replace Repair	0.1	0.3 0.7			56 45,46,56,75 55	A	
0502	Fan Shroud	Replace		1.0			75		
0503	Thermostat Housing	Replace Repair		0.5 0.5			75 17,34,75		
0504	Water Pump Assembly	Replace		3.0			56,75		
0505	Fan Assembly								
	Fan Drive Support	Replace			0.6		54,75		
	Fan Clutch and Drive	Replace Repair		2.0		1.5	75 54,75		
	Fan Belt	Inspect Replace	0.1				75		
	Spindle and Housing	Replace Repair		1.5		3.0	54,75 75		
0508	Water Filter	Replace		0.3			56		
<b>06</b>	<b>ELECTRICAL SYSTEM</b>								
0601	Generator, Alternator								
	Alternator w/Regulator	Test Replace Repair		0.3 0.3		0.5	47,55,57,70 75 55,74		
	Alternator	Test Replace		0.3 0.3		0.5	47,55,57,70 75	F	
	Voltage Regulator (remote-mounted)	Test Replace		0.3 0.3		0.5	47,55,57,70 75	F	
	Drive Belt	Inspect Replace	0.1				75		
0603	Starter	Replace Repair		1.5		2.0	75 60,80		
0605	Ignition Components								
	Engine Harnesses (Electrical)	Test Replace Repair		0.2 0.3	1.0		57 75 57,75		

Table 1. MAC for the Glider Family of Vehicles - Continued.

(1) Group Number	(2) Component/ Assembly	(3) Maintenance Function	(4) Maintenance Level					(5) Tools and Equipment REF CODE	(6) Remarks Code
			FIELD		SUSTAINMENT				
			Unit		DS	GS	Depot		
			C	O	F	H	D		
<b>06</b>	<b>ELECTRICAL SYSTEM - Continued</b>								
0607	Instrument Panel								
	Instrument Panel Switches	Replace		0.3				75	
	Turn Signal Switches	Replace		0.3				75	
0608	Miscellaneous Items								
	ABS ECU	Test		0.3				1,42,66,70	
		Replace		0.5				75	
	Transmission ECU/TCM	Test		0.3				17,42,66,70	
		Replace		0.5				75	
	Collision Warning System (CWS) ECU	Test		0.3				16,42,66,70	
		Replace		0.3				75	
		Repair		0.3				75	
	Fuse, Relay, and Circuit Breaker Panel	Inspect	0.1						
		Replace		0.1				75	
	Diagnostic Connector	Replace		0.5				75	
0609	Lights								
	Headlights	Inspect	0.1						
		Adjust		0.3				75	
		Repair		0.2				75	
	Taillights	Inspect	0.1						
		Replace		0.2				75	
	Blackout Lights	Inspect	0.1						
		Replace		0.2				75	
	Side Marker Lights	Inspect	0.1						
		Replace		0.3				75	
	Fog Lamps (If Equipped)	Replace		0.3				75	
		Repair		0.2				75	
	Marker Clearance Lights	Inspect	0.1						
		Replace		0.3				75	
	Daytime Running Lights	Inspect	0.1						
		Replace		0.2				75	
		Repair		0.3				75	
0610	Sending Units and Warning Switches								
	Air Pressure Warning Sensors	Replace		0.5				75	
	ABS Sensors	Replace		0.5				75	
0611	Horn, Siren								
	Electric Horn	Replace		0.2				75	

Table 1. MAC for the Glider Family of Vehicles - Continued.

(1) Group Number	(2) Component/ Assembly	(3) Maintenance Function	(4) Maintenance Level				(5) Tools and Equipment REF CODE	(6) Remarks Code	
			FIELD		SUSTAINMENT				
			Unit		DS	GS			Depot
			C	O	F	H			D
<b>06</b>	<b>ELECTRICAL SYSTEM - Continued</b>								
	Batteries	Test	0.2			57			
		Replace	0.5			75	B		
0613	Master Battery Switch	Replace	0.5			75			
	Chassis Wiring Harnesses								
	Chassis Harness	Test	0.2			57			
		Replace		2.0		75			
		Repair	0.3			57,75			
	Cab Harness	Test	0.2			57			
		Replace		2.0		75			
		Repair	0.3			57,75			
	ABS, Electrical Harnesses	Test	0.2			57			
		Replace	0.5			75			
	Overhead Cab Harness	Test	0.2			57			
		Replace		0.2		75			
		Repair		0.3		57,75			
<b>07</b>	<b>TRANSMISSION</b>								
0705	Transmission Shifting Components								
	Shift Tower Controls	Replace	0.3			75			
		Repair	1.5			75			
	Dash Mounted Shift Control Panel	Replace	0.3			75	F		
		Repair	1.5			75			
	Wiring Harness	Replace	0.5			75			
	Sensors	Replace	0.3			75			
	Control Module	Replace			1.0	75			
0710	Fill/Check Tube	Replace	0.3			75			
	Yoke	Replace		0.3		75			
	Transmission Assembly	Service	1.0			56,75			
		Test	0.3	0.5		17,70			
		Replace		8.0		4,6,7,54,59,75			
		Repair			10.0	6,7,8,9,10,22,24,27,28,29,30,32,37,38,43,49,50,51,52,54,57,58,62,75,78			
	Transmission Assembly Gen4	Service	1.0			56,75			
		Test	0.3	0.5		17,70,81			
		Replace		8.0		4,6,7,54,59,75			
		Repair			10.0	6,7,8,9,10,22,24,27,28,29,30,32,37,38,38.1,43,48.1,49,50,51,52,54,57,58,62,75,78			

Table 1. MAC for the Glider Family of Vehicles - Continued.

(1) Group Number	(2) Component/ Assembly	(3) Maintenance Function	(4) Maintenance Level				(5) Tools and Equipment REF CODE	(6) Remarks Code	
			FIELD		SUSTAINMENT				
			Unit		DS	GS			Depot
			C	O	F	H			D
<b>07</b>	<b>TRANSMISSION - Continued</b>								
	Torque Converter	Replace			0.5		41,75		
		Repair				1.0	14,31,54,81		
	Flex Plate and Ring Gear	Replace			8.0		44,54,75		
	Flywheel Assembly	Replace			1.0		41,54,75		
		Repair				0.8	54,75		
	Oil Pan	Replace		0.5			57,75		
	Transmission Filters	Replace		0.5			57,75		
0721	Oil Cooler and Hoses	Replace		0.5			57,75		
<b>09</b>	<b>PROPELLER SHAFTS</b>								
0900	Propeller Shaft Assembly	Inspect	0.1	0.2					
		Service		0.2			56		
		Replace		1.9			57,75		
		Repair		1.0			57,75		
<b>10</b>	<b>FRONT AXLE</b>								
1000	Front Axle Assembly	Inspect	0.3						
		Service		0.1			56,75		
		Align		1.0			56,75		
		Replace			4.5		54,75		
		Repair			4.0		54,75		
1004	Tie Rod Knuckle	Replace			0.8		75		
		Repair			1.0		56,75		
<b>11</b>	<b>REAR AXLE</b>								
1100	Forward-rear Axle	Inspect	0.1						
		Service		0.2			56,63,75		
		Replace			4.5		54,75		
		Repair				8.0	56,75		
	Rear-rear Axle	Inspect	0.1						
		Service		0.2			56,63,75		
		Replace			3.0		54,75		
		Repair				8.0	55,75		
1102	Differential	Replace				1.0	55,75		
		Repair				10.5	20,55,63,75		
<b>12</b>	<b>BRAKES</b>								
1202	Service Brakes								

Table 1. MAC for the Glider Family of Vehicles - Continued.

(1) Group Number	(2) Component/ Assembly	(3) Maintenance Function	(4) Maintenance Level				(5) Tools and Equipment REF CODE	(6) Remarks Code		
			FIELD		SUSTAINMENT					
			Unit		DS	GS			Depot	
			C	O	F	H			D	
12	<b>BRAKES - Continued</b>									
	Hanging Brake Assembly	Replace		1.0				75		
		Repair		0.3				75		
	Front Brakes	Inspect		0.7						
		Service		0.1				75		
		Adjust		0.5				75		
		Replace		2.0				56,75		
	Rear Brakes	Inspect		0.7						
		Service		0.1				75		
		Adjust		0.5				75		
		Replace		2.0				56,75		
	1206	Slack Adjusters	Replace		0.3				68,75	
1208	Airbrake System	Brake Chambers	Inspect	0.1	0.2					
			Replace		1.3				75	
	Air Dryer	Service		0.5				75		
		Replace		0.5				75		
		Repair			0.8			54,75		
	Foot Brake Valve	Replace		0.2				75		
		Repair				1.0		54,75		
	Air Valves	Replace		0.3				75		
	Air Reservoir	Replace		0.3				75		
	ABS Valves	Replace		0.5				75		
		Repair		0.5				75		
	1209	Air Compressor	Replace		1.0				56,75	
13	<b>WHEELS</b>									
	1311	Wheel Assembly	Service	0.1						
			Inspect	0.1	0.5					
			Replace	1.0					56,75	
			Repair		0.1				56,75	
	Rear Hub and Drum	Replace		0.5				56,75		
		Repair				1.0		56,75		
	Front Hub and Drum	Replace		0.5				56,75		
		Repair				1.0		21,56,75		
	ABS Tone Ring	Replace		0.5				25,75		
	1313	Tires	Replace		0.1				56,75	
			Repair				0.5		75	C



Table 1. MAC for the Glider Family of Vehicles - Continued.

(1) Group Number	(2) Component/ Assembly	(3) Maintenance Function	(4) Maintenance Level				(5) Tools and Equipment REF CODE	(6) Remarks Code	
			FIELD		SUSTAINMENT				
			Unit		DS	GS			Depot
			C	O	F	H			D
<b>14</b>	<b>STEERING</b>								
1401	Mechanical Steering Gear Assembly Steering System	Inspect Test Service	0.8	1.0 1.0 0.3			56,75		
	Steering Wheel	Replace		1.0			55,75		
	Tilt/Telescope Steering Column	Replace			1.0		75		
	Steering Universal Joint and Shaft	Replace Repair		3.0 1.0			75		
1407	Steering Gear	Replace Repair			0.5	2.5	54,75 3,26,31,33,55, 64,65,75,80		
1410	Power Steering Pump	Test Replace			0.3 0.7		73,75 54,75		
1411	Power Steering Hoses	Inspect Replace		0.1 0.5			75		
1413	Reservoir Assembly and Bracket	Service Replace Repair	0.1				75 57,75		
<b>15</b>	<b>FRAME ASSEMBLY</b>								
1501	Frame Components	Inspect Replace	0.5	0.5		2.1	55,75		
	Ramp Assembly	Inspect Replace	0.1			0.3	55,75		
1503	Pintle Hook	Inspect Service Replace Repair	0.1	0.2 0.1 0.5 0.5			56 75 75		
1504	Spare Tire Carrier	Replace Repair		1.0 0.5			75 75		
1506	Fifth Wheel Fifth Wheel Assembly	Inspect Service Adjust Replace Repair	0.3			2.0 1.0	56 15,71,72,75 60,75 75		
	Tilt Stops	Replace		0.3			75		

Table 1. MAC for the Glider Family of Vehicles - Continued.

(1)  Group Number	(2)  Component/ Assembly	(3)  Maintenance Function	(4) Maintenance Level				(5)  Tools and Equipment REF CODE	(6)  Remarks Code	
			FIELD		SUSTAINMENT				
			Unit		DS	GS			Depot
			C	O	F	H			D
<b>16</b>	<b>SPRINGS AND SHOCKS</b>								
1601	Springs, Front	Replace			1.0			54,75	
	Springs, Rear	Replace			4.0			54,75	
1605	Torque Rods	Replace			1.0			54,75	
<b>18</b>	<b>BODY, CAB, AND HOOD</b>								
1801	Body, Cab, and Hood Cab Assembly	Inspect Replace Repair	0.1				4.0 3.0	61,75 55,75,77	
	Doors	Replace Repair			0.4 0.7			75 75	
	Hood	Adjust Replace Repair		0.3 0.5				75 57,75 54,75	
1802	Fenders, Windshield, Glass								
	Windshield and Windows	Inspect Replace	0.1		1.5			54,75	
	Quarter Fender	Replace		0.4				75	
1805	Floor Covers	Replace		1.0				75	
1806	Seats								
	Seat Belt Assembly	Inspect Replace	0.1					75	
	Seat Assembly	Inspect Replace Repair	0.1	0.2 0.5 2.0				75 75 54,75	
1808	Storage Boxes	Replace Repair		0.5 0.5				75 75	
<b>22</b>	<b>BODY, CHASSIS, ACCESSORY ITEMS</b>								
2202	Accessory Items								
	Mirrors	Replace Repair		0.5 0.5				75 75	
	Mirrors (Heated w/ Remote Control)	Replace Repair		0.5 0.5				75 75	
	Windshield Washer and Motor	Service Replace	0.1		1.2			75	

Table 1. MAC for the Glider Family of Vehicles - Continued.

(1) Group Number	(2) Component/ Assembly	(3) Maintenance Function	(4) Maintenance Level				(5) Tools and Equipment REF CODE	(6) Remarks Code	
			FIELD		SUSTAINMENT				
			Unit		DS	GS			Depot
			C	O	F	H			D
<b>22</b>	<b>BODY, CHASSIS, ACCESSORY ITEMS - Continued</b>								
2210	Data Plates	Replace		0.2			75		
<b>33</b>	<b>SPECIAL PURPOSE KITS</b>								
3303	Arctic Personnel and Engine Heater Kit	Install Replace		2.0 1.0			75 75		
3307	Air Deflector Kit	Replace		1.0			75		
<b>34</b>	<b>ARMAMENT MATERIAL</b>								
3402	Rifle Mounting Kit	Replace		0.5			75		
<b>42</b>	<b>ELECTRICAL EQUIPMENT</b>								
4209	Beacon Warning Light Kit	Install Replace		0.5 0.5			75 75		
<b>47</b>	<b>GAGES (NON- ELECTRICAL)</b>								
4701	Tachometer and Cable	Replace		0.5					
4702	Air Pressure Gages	Replace		0.5			75		
<b>52</b>	<b>REFRIGERATION, AIR CONDITIONER/ HEATER, AND AIR CONDITIONING COMPONENTS</b>								
5200	Heater/Air Conditioner System	Inspect Service Replace Repair	0.1		1.5 2.0 1.0		39 39,48,69,75 54,75 54,75		
	Heater/Air Conditioner Controls	Replace		0.2			75		
5201	Compressor Drive Compressor Clutch Belt	Replace Replace		0.8 1.0			19,75 56,75		
	Compressor	Replace			1.0		54,75		
5217	Valves and Lines	Replace			0.5		39,48,75		
5230	Condenser	Replace			1.0		39,48,75		
	Receiver-dryer	Replace			1.0		39,48,75		

Table 1. MAC for the Glider Family of Vehicles - Continued.

(1) Group Number	(2) Component/ Assembly	(3) Maintenance Function	(4) Maintenance Level				(5) Tools and Equipment REF CODE	(6) Remarks Code	
			FIELD		SUSTAINMENT				
			Unit		DS	GS			Depot
			C	O	F	H			D
<b>68</b>	<b>WARNING AND SIGNALING DEVICES</b>								
6806	Collision Warning System (CWS)	Inspect Align Repair	0.1	1.0 0.5	1.0		40,75 16,70,75		
<b>91</b>	<b>CHEMICAL, BIOLOGICAL, AND RADIOLOGICAL (CBR) EQUIPMENT</b>								
9120	M13 Decontamination Mounting Kit	Replace		0.5			75		
9131	Harness, M22 Chemical Agent Alarm	Replace Repair		0.3	0.5		75 75		

Table 2. Tools and Test Equipment Requirements for the Glider Family of Vehicles.

(1) TOOL OR TEST EQUIPMENT REFERENCE CODE	(2) MAINTENANC E LEVEL	(3) NOMENCLATURE	(4) NATIONAL STOCK NUMBER	(5) TOOL NUMBER
1	O	ABS Test Adapter	4910-01-372-3128	446 300 3140
2	F	Adapter, Torque Wrench	5120-00-215-8200	0TCEDBX15-16
3	F	Adjusting Tool, Worm Shaft	5120-01-371-7369	J37070
4	F	Barring Tool, Engine	5120-01-322-3498	J36237
5	F	Block		5255
6	F	Bracket, Mounting	5340-01-475-3497	J41445
7	F	Bracket, Vehicular Components	2590-01-475-7886	J35926-A
8	H	Bushing, Sleeve	3120-01-475-1603	J37041
9	H	Compressor, Spring	5120-01-476-9381	J41462
10	H	Compressor, Spring	5120-01-476-9379	J35924
11	F	Cover		5250
12	H	Extractor		5226
13	H	Extractor		5227
14	H	Gage, Profile	5220-01-388-1460	J-38548-A
15	O	Gage, Profile	5220-01-357-4913	TF-0237
16	H	Handle, Driver	5120-00-677-2259	J8092
17	O	Handle, Driver	5120-00-977-5578	J7079-2
18	O	Harness, Wiring	6150-01-354-2604	J 35751
19	O	Holder, Clutch	5120-01-439-0305	99-499
20	F	Holding Bar, Pinion	5120-01-455-0436	J 3453-1
21	O	Indicator, Dial	5210-00-402-9619	J7872
22	H	Inserter and Remover	5120-01-476-9378	J37030-3
23	F	Inserter and Remover, Bearing/Bushing	5120-01-338-7182	J25447-B
24	H	Inserter and Remover, Spring	5120-01-388-5623	J35923-2
25	O	Inserter, ABS Ring	5120-01-479-4986	CM/107119
26	F	Inserter, Bearing and Bushing	5120-01-354-2943	J 37071
27	H	Inserter, Bearing and Bushing	5120-01-475-7610	J39954
28	H	Inserter, Bearing and Bushing	5120-01-475-7608	J37033
29	H	Inserter, Bearing and Bushing	5120-01-476-9377	J37038
30	H	Inserter, Bearing and Bushing	5120-01-477-2749	J37040
31	H	Inserter, Bearing and Bushing	5120-01-475-7609	J39949
32	H	Inserter, Bearing and Bushing	5120-01-476-9380	J37036
33	F	Installation Tool, Seal	5120-01-354-0468	J 37073

Table 2. Tools and Test Equipment Requirements for the Glider Family of Vehicles - Continued.

(1) TOOL OR TEST EQUIPMENT REFERENCE CODE	(2) MAINTENANC E LEVEL	(3) NOMENCLATURE	(4) NATIONAL STOCK NUMBER	(5) TOOL NUMBER
34	O	Installer, Seal	5120-00-977-5579	J8550
35	F	Installer, Seal	5120-01-441-1065	J42381
36		Installer, Seal		5257
37	F	Installer, Seal, Input	5120-01-492-7522	J37032
38	F	Installer, Seal, Output	5120-01-492-7521	J37031
38.1	F	Installer, Slinger		J46150
39	O	Leak Detector, Refrigerant Gas	4940-01-387-0948	16600
40	O	Level, Digital	5210-01-494-0899	J38460-A
41	F	Lifting, Bracket, Flywheel	5120-01-116-6049	J-24365
42	O	MSD/ICE	6625-01-493-8968	13580880
43	H	Parts Kit, Valves	4810-01-477-1579	J-33163
44	F	Pin, Shoulder, Headless	5315-01-333-2771	J36235
45	O	Pliers, Hose Clamp		J38185
46	O	Plier, Slip Joint	5120-00-537-3375	18P
47	F	Pliers, Retaining Ring	5120-01-322-6888	J36347
48	F	Reclaimer, Refrigerant	4250-01-396-8928	EEAC304D
48.1	F	Remover, Seal	5180-01-048-2153	J-24171-A
49	H	Remover, Wheel Bearing Cup	5120-00-784-6482	J3940
50	H	Ring, Retaining	5325-01-475-4635	J37030-1
51	H	Ring, Retaining	5325-01-475-4745	J37030-2
52	H	Seal Installer	5120-01-481-2193	8HE542
53	F	Shield, Turbo Protective	4910-01-127-7959	J26554-A
54	F	Shop Equipment, Automotive, DS Maintenance, Basic	4910-00-754-0705	SC4910-95CLA31
55	F	Shop Equipment, Automotive, DS Maintenance, Set A	4910-00-348-7696	SC4910-95CLA02
56	O	Shop Equipment, Automotive, Unit Maintenance, Common #1	4910-00-754-0654	SC4910-95CLA74
57	O	Shop Equipment, Automotive, Unit Maintenance, Common #2	4910-00-754-0650	SC4910-95CLA72
58	O	Shop Equipment, Automotive, DS Maintenance, Suppl. 1	4910-00-754-0707	SC4910-95CLA63
59	F	Shop Equipment, Automotive, DS Maintenance, Suppl. 2	4910-00-754-0706	SC4910-95CLA62
60	F	Slider, Spring Compression	4910-01-165-6015	TFTLN-2500
61	F	Sling, Beam Type	3940-01-353-8561	J-39520

Table 2. Tools and Test Equipment Requirements for the Glider Family of Vehicles - Continued.

(1) TOOL OR TEST EQUIPMENT REFERENCE CODE	(2) MAINTENANC E LEVEL	(3) NOMENCLATURE	(4) NATIONAL STOCK NUMBER	(5) TOOL NUMBER
62	H	Socket, Socket Wrench	5120-01-478-8622	J39534
63	O	Socket, Socket Wrench	5130-01-389-8450	BWD482
64	F	Socket, Socket Wrench	5120-01-355-4791	XE-16
65	F	Spanner Attachment, Socket Wrench	5120-01-353-8490	J 37464
66	O	SPORT/ICE	6625-01-445-0085	13580703
67	O	Stripper, Wire Hand	5110-01-355-0848	J35615
68	O	Template, Slack Adjuster (See WP 0300 00)		Manufactured
69	F	Test Set	6685-01-438-5088	J38509
70	O	Tester, PRO-Link, Diagnostic Reader		J38500-H
	O	• Adapter, Connector, 6-pin	5935-01-477-7230	J38500-60A
	O	• Adapter, Connector, 9-pin		J-38500-90
	O	• PC Card, ABS	7025-01-482-9014	J-38500-4100C
	O	• PC Card, CTIS/CWS	7025-01-482-8911	J-38500-1300I
	O	• PC Card, Transmission	7025-01-482-8961	J-38500-1800A
	O	• Tester, PRO-Link	4910-01-491-0701	J-38500-1A
	O	•• Adapter, Electrical	5935-01-353-2532	J 34812-1
	O	•• Adapter, PC Card	7025-01-482-8761	J-38500-1500C
	O	•• Cable Assembly, Special	6150-01-353-9708	J 38500-2
71	O	Tester, Kingpin Lock	4910-01-157-3571	TFTLN-5001
72	O	Tester, Kingpin Lock	4910-01-157-3572	TFTLN-1500
73	F	Tester, Power Steering	4910-01-160-3618	J26487-C
74	F	Tool Kit, Automotive Fuel and Electrical System Repair	5180-00-754-0655	SC5180-95-CL-B08
75	O	Tool Kit, General Mechanic's	5180-01-481-8389	DFP389J
76	O	Tool Kit, Internal Combustion Engine	5180-01-358-5231	J 35888-60
77	H	Tool Kit, Metal Worker's	5180-00-596-1510	SC5180-90-CL-N19
78	H	Tool Kit, Transmission	5180-01-476-2361	J-37035
79	F	Tool, Bearing		5256
80	H	Tool, Torque Converter Bolt	5120-01-493-8389	J38564
81	O, F	Transmission Diagnostic Tool	TBD	TBD

**Table 3. Remarks for the Glider Family of Vehicles.**

<b>(1)</b> <b>REMARKS CODE</b>	<b>(2)</b> <b>REMARKS</b>
A	Refer to TM 750-254 (cooling systems) for additional information.
B	Refer to TM 9-6140-200-14 (batteries) for additional information.
C	Refer to TM 9-2610-200-14 (tires) for additional information.
D	Requires SRA for ECU programming/disposition.
E	All maintenance procedures for engine and engine components are found in TM 9-2815-225-34&P.
F	Component on M915A4R2.
G	Front axle of M915A4 rated at 12K, front axle of M915A4R2 rated at 14K.

**END OF WORK PACKAGE**



**ILLUSTRATED LIST OF MANUFACTURED ITEMS****0310 00****SCOPE**

1. This work package includes complete instructions for making items authorized to be manufactured or fabricated at Unit, Direct Support, and General Support Maintenance.
2. A Part Number Index in alphanumeric order is provided in Table 1 for cross-referencing the part number of the item to be manufactured to Table 2, which covers fabrication criteria.
3. All bulk materials needed for manufacture of an item are listed by part number or specification number.

**PART NUMBER INDEX****Table 1. Part Number Index.**

<b>PART NUMBER</b>	<b>NAME</b>	<b>TABLE NUMBER</b>
FITC-02	Cable, Special Purpose	2
NT10010-BKX13	Tube, Nylon	2
NT10010-BKX16	Tube, Nylon	2
NT10010-BKX40	Tube, Nylon	2
NT10010-BKX175	Tube, Nylon	2
PFT-4A	Tubing, Nonmetallic	2
PFT-4A-BLK-100X13	Tube, Nylon	2
PFT-4A-BLK-100X46	Tube, Nylon	2
PFT-4A-BLK-100X48	Tube, Nylon	2
PFT-4A-BLK-100X54	Tube, Nylon	2
PFT-4A-BLK-100X70	Tube, Nylon	2
PFT-4A-BLK-100X78	Tube, Nylon	2
PFT-4A-BLK-100X85	Tube, Nylon	2
PFT-4A-BLK-100X93	Tube, Nylon	2
PFT-4A-BLK-100X159	Tube, Nylon	2
PFT-4A-BLK-100X225	Tube, Nylon	2
PFT-6B-BLK-100X6	Tube, Nylon	2
PFT-6B-BLK-100X15	Tube, Nylon	2
PFT-6B-BLK-100X18	Tube, Nylon	2
PFT-6B-BLK-100X25	Tube, Nylon	2
PFT-6B-BLK-100X34	Tube, Nylon	2
PFT-6B-BLK-100X36	Tube, Nylon	2
PFT-6B-BLK-100X40	Tube, Nylon	2
PFT-6B-BLK-100X42	Tube, Nylon	2
PFT-6B-BLK-100X52	Tube, Nylon	2
PFT-6B-BLK-100X53	Tube, Nylon	2
PFT-6B-BLK-100X70	Tube, Nylon	2

Table 1. Part Number Index - Continued.

PART NUMBER	NAME	TABLE NUMBER
PFT-6B-BLK-100X75	Tube, Nylon	2
PFT-6B-BLK-100X79	Tube, Nylon	2
PFT-6B-BLK-100X100	Tube, Nylon	2
PFT-6B-BLK-100X113	Tube, Nylon	2
PFT-6B-BLK-100X115	Tube, Nylon	2
PFT-6B-BLK-100X119	Tube, Nylon	2
PFT-6B-BLK-100X120	Tube, Nylon	2
PFT-6B-BLK-100X130	Tube, Nylon	2
PFT-6B-BLK-100X149	Tube, Nylon	2
PFT-6B-BLK-100X150	Tube, Nylon	2
PFT-6B-BLK-100X159	Tube, Nylon	2
PFT-8B-BLK-100X1	Tube, Nylon	2
PFT-8B-BLK-100X7	Tube, Nylon	2
PFT-8B-BLK-100X36	Tube, Nylon	2
PFT-8B-BLK-100X50	Tube, Nylon	2
PFT-8B-BLK-100X60	Tube, Nylon	2
PFT-8B-BLK-100X78	Tube, Nylon	2
PFT-8B-BLK-100X100	Tube, Nylon	2
PFT-8B-BLK-100X115	Tube, Nylon	2
PFT-8B-BLK-100X121	Tube, Nylon	2
PFT-8B-BLK-100X130	Tube, Nylon	2
PFT-8B-BLK-100X140	Tube, Nylon	2
P52-6738	Coupling, Assembly	2
04-9323-013	Pipe, Flex	2
05-09562-005	Hose, Neoprene	2
05-09562-006	Hose, Straight	2
05-09564-008	Hose, Neoprene	2
05-12538-036	Hose	2
05-12539-043	Hose, Straight	2
05-15224-004	Hose, Rubber	2
06-18131-000	Liner, Plywood	2
12-13366-040	Tube, Nylon	2
12-13367-045	Tube, Nylon	2
12-13367-060	Tube, Nylon	2
12-13367-105	Tube, Nylon	2
12-13367-142	Tube, Nylon	2
12-13367-200	Tube, Nylon	2

Table 1. Part Number Index - Continued.

PART NUMBER	NAME	TABLE NUMBER
12-13370-037	Tube, Nylon	2
12-13371-037	Tube, Nylon	2
12-13374-006	Tube, Nylon	2
12-13472-019	Tube, Nylon	2
12-13473-040	Tube, Nylon	2
18-11197-001X10	Trim, Edging	2
22-21952-004	Hose	2
22-21952-018	Hose	2
22-21952-020	Hose	2
22-21952-048	Hose	2
22-21952-052	Hose	2
22-21952-063	Hose, Heater	2
22-28607-018	Hose, Heater	2
22-28607-061	Hose, Rubber	2
22-30167-030	Hose, Heater	2
22-30168-003	Hose, Heater	2
22-30168-034	Hose, Heater	2
22-35191-010	Seal	2
22-35281-016	Hose, Rubber	2
22-35281-030	Hose, Rubber	2
22-35282-025	Hose, Rubber	2
22-35282-090	Hose, Rubber	2
22-35282-135	Hose, Rubber	2
23323FX-48	Hose, Nonmetallic	2
350359X0.3	Hose, Coolant	2
350359X1.8	Hose, Coolant	2
350359X3.5	Hose, Coolant	2
350359X3.8	Hose, Coolant	2
4246-0410X5	Tubing, Nylon	2
47336AX	Hose, Nonmetallic	2
47338AX	Hose, Nonmetallic	2
48-00050-206X6	Tape, Foam	2
48-00081-038X24	Hose	2
48-00099-150X3	Hose	2
48-00100-010X5	Tubing, Nylon	2
48-00100-010X10	Tubing, Nylon	2
48-00100-010X15	Tubing, Nylon	2

Table 1. Part Number Index - Continued.

PART NUMBER	NAME	TABLE NUMBER
48-00100-812X15	Tubing, Nylon	2
48-00100-812X18	Tubing, Nylon	2
48-00100-814X16	Tubing, Nylon	2
48-00100-815X15	Tubing, Nylon	2
48-00100-816X6	Tubing, Nylon	2
48-00100-816X18	Tubing, Nylon	2
48-00100-816X48	Tubing, Nylon	2
48-00100-829X12	Tubing, Nylon	2
48-00100-829X36	Tubing, Nylon	2
48-00100-829X56	Tubing, Nylon	2
48-00101-010X7	Tube, Nylon	2
48-00101-010X48	Hose	2
48-00101-010X72	Hose	2
48-00101-010X96	Hose	2
48-00101-010X144	Hose	2
48-00101-010X180	Hose	2
48-00101-010X264	Hose	2
48-00101-020X24	Hose, Nonmetallic	2
48-00101-020X48	Hose, Nonmetallic	2
48-00101-020X96	Hose, Nonmetallic	2
48-00101-020X120	Hose, Nonmetallic	2
48-00101-022X1	Tube, Nylon	2
48-00101-030X10	Tube, Nylon	2
48-00101-030X108	Hose, Nonmetallic	2
48-00121-016X30	Hose	2
48-00121-016X53	Hose	2
48-02014-008X48	Hose	2
48-02015-012X24	Hose, Rubber	2
48-02217-025X5	Conduit, Nonmetallic	2
48-02217-025X36	Tubing, Nonmetallic	2
48-02217-050X3	Conduit	2
48-02217-050X8	Conduit	2
48-02217-062X3	Conduit	2
48-02217-062X105	Conduit	2
48-02217-075X57.08	Conduit	2
48-02218-050X105	Conduit	2
48-02218-075X12	Conduit	2

Table 1. Part Number Index - Continued.

PART NUMBER	NAME	TABLE NUMBER
48-02454-106X27	Tape, Foam	2
48-02454-206X12	Tape, Ureth Foam	2
48-02471-001X8	Seal, Door	2
48-02471-001X55	Seal	2
5156170	Hose	2
68240R-276	Conduit	2
77551	Hose	2
77620-7.5	Hose	2

Table 2. Manufactured Items.

PART NUMBER	NAME	MANUFACTURED FROM	DESCRIPTION
FITC-02	CABLE, SPECIAL PURPOSE	M83420/1-005	144 IN LONG
NT10010-BKX13	TUBE, NYLON	3250-1010	40 IN LONG
NT10010-BKX16	TUBE, NYLON	3250-1010	13 IN LONG
NT10010-BKX40	TUBE, NYLON	3250-1010	40 IN LONG
NT10010-BKX175	TUBE, NYLON	3250-1010	175 IN LONG
PFT-4A	TUBING, NONMETALLIC	PFT-4A BLACKX1300	CUT TO FIT
PFT-4A-BLK-100X13	TUBE, NYLON	PFT-4A BLACKX1300	13 IN LONG
PFT-4A-BLK-100X46	TUBE, NYLON	PFT-4A BLACKX1300	46 IN LONG
PFT-4A-BLK-100X48	TUBE, NYLON	PFT-4A BLACKX1300	48 IN LONG
PFT-4A-BLK-100X54	TUBE, NYLON	PFT-4A BLACKX1300	54 IN LONG
PFT-4A-BLK-100X70	TUBE, NYLON	PFT-4A BLACKX1300	70 IN LONG
PFT-4A-BLK-100X78	TUBE, NYLON	PFT-4A BLACKX1300	78 IN LONG
PFT-4A-BLK-100X85	TUBE, NYLON	PFT-4A BLACKX1300	85 IN LONG
PFT-4A-BLK-100X93	TUBE, NYLON	PFT-4A BLACKX1300	93 IN LONG
PFT-4A-BLK-100X159	TUBE, NYLON	PFT-4A BLACKX1300	159 IN LONG
PFT-4A-BLK-100X225	TUBE, NYLON	PFT-4A BLACKX1300	225 IN LONG
PFT-6B-BLK-100X6	TUBE, NYLON	3250-061	6 IN LONG
PVT-6B-BLK-100X15	TUBE, NYLON	3250-061	15 IN LONG
PFT-6B-BLK-100X18	TUBE, NYLON	3250-061	18 IN LONG
PFT-6B-BLK-100X25	TUBE, NYLON	3250-061	25 IN LONG

Table 2. Manufactured Items - Continued.

PART NUMBER	NAME	MANUFACTURED FROM	DESCRIPTION
PFT-6B-BLK-100X34	TUBE, NYLON	3250-061	34 IN LONG
PFT-6B-BLK-100X36	TUBE, NYLON	3250-061	36 IN LONG
PFT-6B-BLK-100X40	TUBE, NYLON	3250-061	40 IN LONG
PFT-6B-BLK-100X42	TUBE, NYLON	3250-061	42 IN LONG
PFT-6B-BLK-100X52	TUBE, NYLON	3250-061	52 IN LONG
PFT-6B-BLK-100X53	TUBE, NYLON	3250-061	53 IN LONG
PFT-6B-BLK-100X70	TUBE, NYLON	3250-061	70 IN LONG
PFT-6B-BLK-100X75	TUBE, NYLON	3250-061	75 IN LONG
PFT-6B-BLK-100X79	TUBE, NYLON	3250-061	79 IN LONG
PFT-6B-BLK-100X100	TUBE, NYLON	3250-061	100 IN LONG
PFT-6B-BLK-100X113	TUBE, NYLON	3250-061	113 IN LONG
PFT-6B-BLK-100X115	TUBE, NYLON	3250-061	115 IN LONG
PFT-6B-BLK-100X119	TUBE, NYLON	3250-061	119 IN LONG
PFT-6B-BLK-100X120	TUBE, NYLON	3250-061	120 IN LONG
PFT-6B-BLK-100X130	TUBE, NYLON	3250-061	130 IN LONG
PFT-6B-BLK-100X149	TUBE, NYLON	3250-061	149 IN LONG
PFT-6B-BLK-100X150	TUBE, NYLON	3250-061	150 IN LONG
PFT-6B-BLK-100X159	TUBE, NYLON	3250-061	159 IN LONG
PFT-8B-BLK-100X1	TUBE, NYLON	C608-100BLK	15 IN LONG
PFT-8B-BLK-100X7	TUBE, NYLON	C608-100BLK	7 IN LONG
PFT-8B-BLK-100X36	HOSE, NONME.	C608-100BLK	36 IN LONG
PFT-8B-BLK-100X50	TUBE, NYLON	C608-100BLK	50 IN LONG
PFT-8B-BLK-100X60	TUBE, NYLON	C608-100BLK	60 IN LONG
PFT-8B-BLK-100X78	TUBE, NYLON	C608-100BLK	78 IN LONG
PFT-8B-BLK-100X100	TUBE, NYLON	C608-100BLK	100 IN LONG
PFT-8B-BLK-100X115	TUBE, NYLON	C608-100BLK	115 IN LONG
PFT-8B-BLK-100X121	TUBE, NYLON	C608-100BLK	121 IN LONG
PFT-8B-BLK-100X130	TUBE, NYLON	C608-100BLK	130 IN LONG
PFT-8B-BLK-100X140	TUBE, NYLON	C608-100BLK	140 IN LONG
P52-6738	COUPLING ASSEMBLY	24032	CUT TO FIT
04-9323-013	PIPE, FLEX	R342S5 25	13 IN LONG
05-09562-005	HOSE, NEOPRENE	24244	5 IN LONG

Table 2. Manufactured Items - Continued.

PART NUMBER	NAME	MANUFACTURED FROM	DESCRIPTION
05-09562-006	HOSE, STRAIGHT	24240	6 IN LONG
05-09564-008	HOSE, NEOPRENE	24248	8 IN LONG
05-12538-036	HOSE, STRAIGHT	4230-0174	36 IN LONG
05-12539-043	HOSE, RUBBER	28430	43 IN LONG
05-15224-004	LINER, PLYWOOD	24228	4 IN LONG
06-18131-000	TUBE, NYLON	CS122-56 GRADE CD INTERIOR TYPE	7X7.5 IN
12-13366-040	TUBE, NYLON	PFT-4A BLACKX1300	40 IN LONG
12-13367-045	TUBE, NYLON	3250-061	45 IN LONG
12-13367-060	TUBE, NYLON	PFT-4A BLACKX1300	60 IN LONG
12-13367-105	TUBE, NYLON	3250-061	105 IN LONG
12-13367-142	TUBE, NYLON	PFT-4A BLACKX1300	142 IN LONG
12-13367-200	TUBE, NYLON	PFT-4A BLACKX1300	200 IN LONG
12-13370-037	TUBE, NYLON	PFT-4A BLACKX1300	37 IN LONG
12-13371-037	TUBE, NYLON	PFT-4A BLACKX1300	37 IN LONG
12-13374-006	TUBE, NYLON	3250-061	6 IN LONG
12-13472-019	TUBE, NYLON	PFT-4A BLACKX1300	19 IN LONG
12-13473-040	TUBE, NYLON	PFT-4A BLACKX1300	40 IN LONG
18-11197-001X10	TRIM, EDGING	48-02188-001	10 FT LONG
22-21952-004	HOSE	4230-0002	4 IN LONG
22-21952-018	HOSE	4230-0002	18 IN LONG
22-21952-020	HOSE	4230-0002	20 IN LONG
22-21952-048	HOSE	4230-0002	48 IN LONG
22-21952-052	HOSE	4230-0002	52 IN LONG
22-21952-063	HOSE, HEATER	4230-0002	63 IN LONG
22-28607-018	HOSE, HEATER	350357	18 IN LONG
22-28607-061	HOSE, RUBBER	MS521301A203R	6 IN LONG
22-30167-030	HOSE, HEATER	4230NX-5/8	30 IN LONG
22-30168-003	HOSE, HEATER	4230NX-3/4	3 FT LONG
22-30168-034	HOSE, HEATER	4230NX-3/4	34 IN LONG
22-35191-010	SEAL	48-02412-525	CUT TO FIT
22-35281-016	HOSE, RUBBER	35055	16 IN LONG
22-35281-030	HOSE, RUBBER	35055	30 IN LONG

Table 2. Manufactured Items - Continued.

PART NUMBER	NAME	MANUFACTURED FROM	DESCRIPTION
22-35282-025	HOSE, RUBBER	35056	25 IN LONG
22-35282-090	HOSE, RUBBER	35056	90 IN LONG
22-35282-135	HOSE, RUBBER	35056	135 IN LONG
23323FX-48	HOSE, NONMETALLIC	3250-061	48 IN LONG
350359X0.3	HOSE, COOLANT	4230-0174	0.3 FT LONG
350359X1.8	HOSE, COOLANT	4230-0174	1.8 FT LONG
350359X3.5	HOSE, COOLANT	4230-0174	3.5 FT LONG
350359X3.8	HOSE, COOLANT	4230-0174	3.8 FT LONG
4246-0410X5	TUBING, NYLON	PFT-4A BLACKX1300	5 FT LONG
47336AX	HOSE, NONMETALLIC	FC350-06	12 IN LONG
47338AX	HOSE, NONMETALLIC	FC350-10	19 IN LONG
48-00050-206X6	TAPE, FOAM	V532X 3/4 INX200FT	6 FT LONG
48-00081-038X24	HOSE	28430	24 IN LONG
48-00099-150X3	HOSE	24224	3 IN LONG
48-00100-010X5	TUBING, NYLON	PFT-4A BLACKX1300	5 FT LONG
48-00100-010X10	TUBING, NYLON	PFT-4A BLACKX1300	10 FT LONG
48-00100-010X15	TUBING, NYLON	PFT-4A BLACKX1300	15 FT LONG
48-00100-812X15	TUBING, NYLON	C602	15 IN LONG
48-00100-812X18	TUBING, NYLON	C602	18 IN LONG
48-00100-814X16	TUBING, NYLON	C602	16 IN LONG
48-00100-815X15	TUBING, NYLON	C602	15 IN LONG
48-00100-816X6	TUBING, NYLON	C602	6 IN LONG
48-00100-816X18	TUBING, NYLON	C602	18 IN LONG
48-00100-816X48	TUBING, NYLON	C602	48 IN LONG
48-00100-829X12	TUBING, NYLON	C602	12 IN LONG
48-00100-829X36	TUBING, NONMETALLIC	4246-02277	36 IN LONG
48-00100-829X56	TUBING, NYLON	C602	56 IN LONG
48-00101-010X7	TUBE, NYLON	3250-061	7 FT LONG
48-00101-010X48	HOSE	PFT-6B-BLK-100	48 IN LONG
48-00101-010X72	HOSE	PFT-6B-BLK-100	72 IN LONG
48-00101-010X96	HOSE	PFT-6B-BLK-100	96 IN LONG
48-00101-010X144	HOSE	PFT-6B-BLK-100	144 IN LONG



Table 2. Manufactured Items - Continued.

PART NUMBER	NAME	MANUFACTURED FROM	DESCRIPTION
48-00101-010X180	HOSE	PFT-6B-BLK-100	180 IN LONG
48-00101-010X264	HOSE	PFT-6B-BLK-100	264 IN LONG
48-00101-020X24	HOSE, NONMETALLIC	C608-100BLK	24 IN LONG
48-00101-020X48	HOSE, NONMETALLIC	C608-100BLK	48 IN LONG
48-00101-020X96	NOSE, NONMETALLIC	C608-100BLK	96 IN LONG
48-00101-020X120	HOSE, NONMETALLIC	C608-100BLK	120 IN LONG
48-00101-022X1	TUBE, NYLON	48-00101-022	1 FT LONG
48-00101-030X10	TUBE, NYLON	3250-1010	10 FT LONG
48-00101-030X108	HOSE, NONMETALLIC	3250-1010	108 IN LONG
48-00121-016X30	HOSE	48-00121-016	30 IN LONG
48-00121-016X53	HOSE	48-00121-016	53. IN LONG
48-02014-008X48	HOSE	4251-0125	48 FT LONG
48-02015-012X24	HOSE, RUBBER	881-12	24 IN LONG
48-02217-025X5	CONDUIT, NONMETALLIC	64498R	5 FT LONG
48-02217-025X36	TUBING, NONMETALLIC	64498R	36 IN LONG
48-02217-050X3	CONDUIT	68237R	3 FT LONG
48-02217-050X8	CONDUIT	68237R	8 IN LONG
48-02217-062X3	CONDUIT	68237R	3 FT LONG
48-02217-062X105	CONDUIT	48-02218-050	105 IN LONG
48-02217-075X57.08	CONDUIT	68240R	57.08 IN LONG
48-02218-050X105	CONDUIT	48-02218-050	105 IN LONG
48-02218-075X12	CONDUIT	48-02218-075	12 IN LONG
48-02454-106X27	TAPE, FOAM	4516 5/8 in	27 IN LONG
48-02454-206X12	TAPE, URETH FOAM	V40624	12 FT LONG
48-02471-001X8	SEAL, DOOR	48-02471-001	8 FT LONG
48-02471-001X55	SEAL	48-02471-001	5.5 FT LONG
5156170	HOSE	MS521301A206R	2.5 IN LONG
68240R-276	CONDUIT	68240R	276 IN LONG
77551	HOSE	IC-26-31C	7.5 IN LONG
77620-7.5	HOSE	IC-26-31C	82 IN LONG

Table 2. Manufactured Items - Continued.

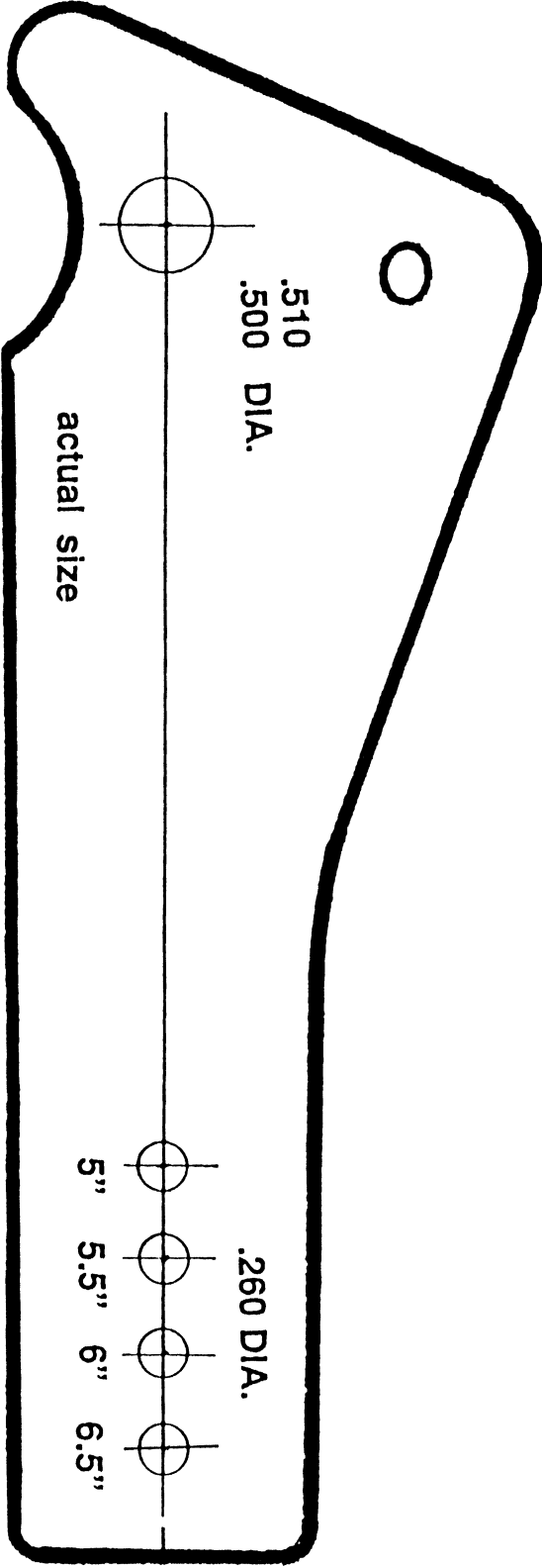
PART NUMBER	NAME	
	AUTOMATIC SLACK ADJUSTER INSTALLATION TEMPLATE	

**FABRICATED TOOLS**1. **Item 1.**a. **Materials.**

- (1) Capscrew, Hex, 1/2 x 2-1/2 x 13 UNC, P/N 23-9440-300
- (2) Sleeve, P/N 166JX

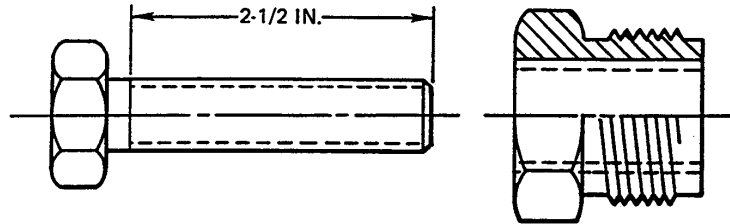

342-889

b. **Fabrication Notes.**

- (1) Drill and tap sleeve, P/N 166JX, for 1/2 x 13 UNC thread.
- (2) Extend length of thread to 2-1/2 in.
- (3) Install screw in sleeve as shown.

**FABRICATED TOOLS - CONTINUED**

2. **Item 2.**

a. **Materials.**

- (1) Cover Plate, P/N 5122281
- (2) Coupling, P/N 5141773
- (3) Bar Stock, 3/4 x 1/2 x 4 in (2)
- (4) Tubing, Heavy Wall, 1/2 in Inside Diameter, 3/4 in Long (4)

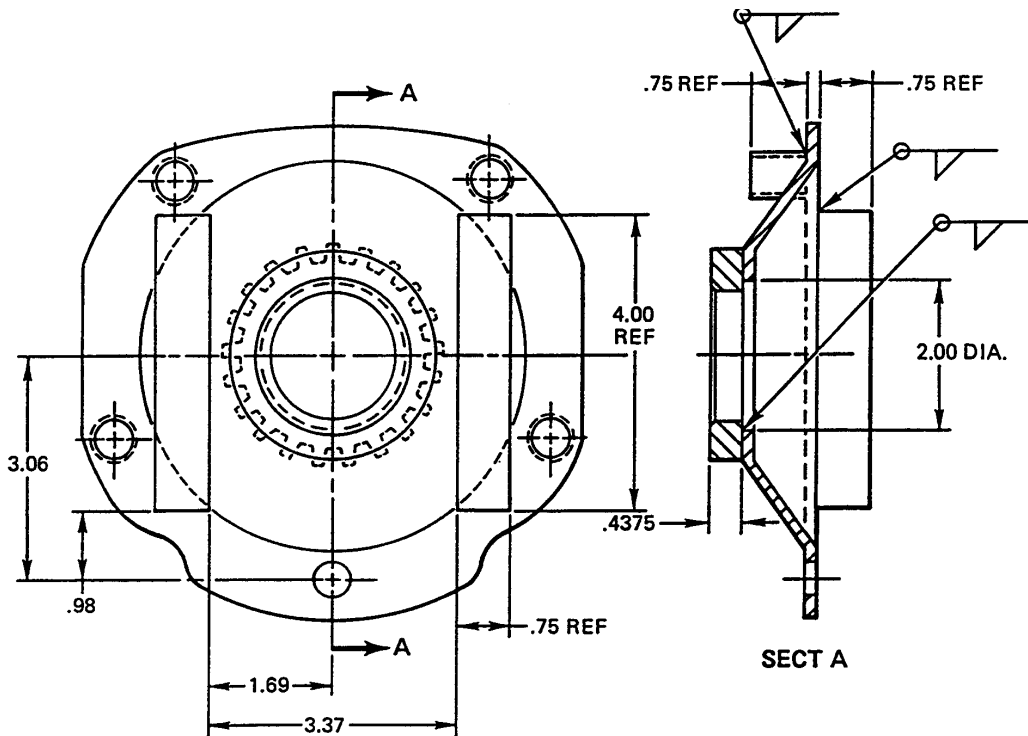

342-890

b. **Fabrication Notes.**

- (1) Cut 2 in diameter hole in center of raised portion of cover plate, P/N 5122281.
- (2) Cut 7/16 in from end of coupling, P/N 5141773.
- (3) Weld four tube sections onto raised side of cover plate, centered on four bolt holes as shown.
- (4) Place shim(s) and 7/8 in section of coupling in hub of either air compressor or air compressor drive. Install cover plate using two bolts to secure it to air compressor or drive. Ensure that coupling contacts cover plate.

---

**ILLUSTRATED LIST OF MANUFACTURED ITEMS - CONTINUED**

---

**0310 00****FABRICATED TOOLS - CONTINUED**

- (5) Tack weld coupling to cover plate. Remove cover plate from air compressor or drive and finish welding coupling to cover plate. Ensure that inside diameter of coupling is free of excess weld.
- (6) Weld two pieces of bar stock to opposite side of cover plate as shown.

3. **Item 3.**a. **Materials.**

Rod, 1/2 x 20 x 13 UNC, P/N 1 213X20INLGSTL

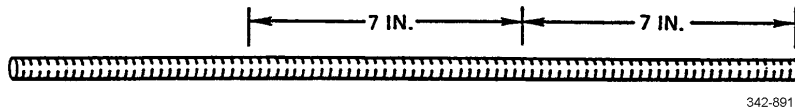

342-891

## b. Fabrication Notes.

- (1) Cut two 7 in lengths.
- (2) Remove all burrs and sharp edges.

**END OF WORK PACKAGE**



**SCOPE**

This work package lists standard torque values and provides general information for applying torque. Special torque values and tightening sequences are indicated in the maintenance procedures for applicable components.

**GENERAL**

1. Always use torque values listed in Table 1 when a maintenance procedure does not give a specific torque value.
2. Unless otherwise indicated, standard torque tolerance shall be  $\pm 10\%$ .
3. Torque values listed are based on clean, dry threads. Reduce torque by 10% when engine oil is used as a lubricant. Reduce torque by 20% if new plated cap screws are used.
4. Cap screws threaded into aluminum may require reductions in torque of 30% or more of Grade 5 cap screw torque. Cap crew threaded into aluminum must also attain two cap screw diameters of thread engagement.
5. If the maintenance procedures do not specify a tightening order, use the following guides:
  - a. Unless otherwise specified, lubricate threads of fasteners with oil (Item 26 or 27, WP 0312 00).
  - b. When tightening fasteners above 30 lb-ft (41 Nm), use the torque pattern but only tighten to 70 percent of final value (multiply final value by 0.7). Repeat pattern until final value is reached.
  - c. Tighten circular patterns using circular torque pattern. Tighten straight patterns using straight torque pattern.

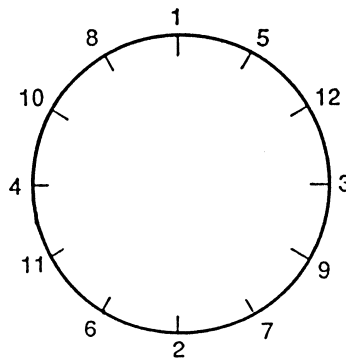

CIRCULAR TORQUE PATTERN

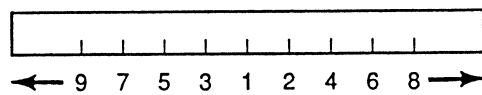

STRAIGHT TORQUE PATTERN

**CAUTION**

If replacement cap screws are of higher grade than originally supplied, use torque specifications for the original. This will prevent equipment damage due to overtightening.

Table 1. Torque Limits.







CURRENT USAGE	MUCH USED	MUCH USED	USED AT TIMES	USED AT TIMES
QUALITY OF MATERIAL	INDETERMINATE	MINIMUM COMMERCIAL	MEDIUM COMMERCIAL	BEST COMMERCIAL
SAE Grade Number	1 or 2	5	6 or 7	8
Cap Screw Head Markings			 	  
Manufacturer's marks may vary				
These are all SAE Grade 5 (3 line)				
CAP SCREW BODY SIZE INCHES - THREAD	TORQUE LB-FT (NM)	TORQUE LB-FT (NM)	TORQUE LB-FT (NM)	TORQUE LB-FT (NM)
1/4 20 28	5 (7) 6 (8)	8 (11) 10 (14)	10 (14)	12 (16) 14 (19)
5/16 18 24	11 (15) 13 (18)	17 (23) 19 (26)	19 (26)	24 (33) 27 (37)
3/8 16 24	18 (24) 20 (27)	31 (42) 35 (47)	34 (46)	44 (60) 49 (66)
7/16 14 20	28 (38) 30 (41)	49 (66) 55 (75)	55 (75)	70 (95) 78 (106)
1/2 13 20	39 (53) 41 (56)	75 (102) 85 (115)	85 (115)	105 (142) 120 (163)
9/16 12 18	51 (69) 55 (75)	110 (149) 120 (163)	120 (163)	155 (210) 170 (231)
5/8 11 18	83 (113) 95 (129)	150 (203) 170 (231)	167 (226)	210 (285) 240 (325)
3/4 10 16	105 (142) 115 (156)	270 (366) 295 (400)	280 (380)	375 (508) 420 (569)
7/8 9 14	160 (217) 175 (237)	395 (536) 435 (590)	440 (597)	605 (820) 675 (915)
1 8 14	235 (319) 250 (339)	590 (800) 660 (895)	660 (895)	910 (1234) 990 (1342)



Table 2. Refrigerant Line Torque Specifications.

OUTSIDE DIAMETER OF METAL TUBE (in)	TORQUE FOR STEEL TUBES* lb-ft (Nm)	TORQUE FOR ALUMINUM OR COPPER TUBES* lb-ft (Nm)
1/4	10-15 (14-20)	6-8 (8-11)
3/8	20-25 (27-34)	11-13 (15-18)
1/2	30-35 (41-47)	15-20 (20-27)
5/8	35-40 (47-54)	21-27 (28-37)
3/4	35-40 (47-54)	28-33 (38-45)

\* When tightening fittings, always use torque reading for softer metal when unlike metals are used.

**END OF WORK PACKAGE**



---

**EXPENDABLE AND DURABLE ITEMS LIST**

---

**0312 00****SCOPE**

This work package lists expendable and durable items you will need to maintain the M915A4. This listing is for information only and is not authority to requisition the listed items. These items are authorized to you by CTA 50-970, *Expendable/Durable Items (Except Medical, Class V Repair Parts, and Heraldic Items)*, or CTA 8-100, *Army Medical Department Expendable/Durable Items*.

**EXPLANATION OF COLUMNS**

1. **Column (1) - Item Number.** This number is assigned to the entry in the list and is referenced in the narrative instructions to identify the item [e.g., Use antifreeze (Item 6, WP 0312 00)].
2. **Column (2) - Level.** This column identifies the lowest level of maintenance that requires the listed item.
  - C - Operator/Crew
  - O - Unit Maintenance
3. **Column (3) - National Stock Number (NSN).** This is the NSN assigned to the item which you can use to requisition it.
4. **Column (4) - Item Name, Description, Commercial and Government Entity Code (CAGEC), and Part Number (P/N).** This provides the other information you need to identify the item.
5. **Column (5) - Unit of Measure (U/M).** This code shows the physical measurement or count of an item, such as gallon, dozen, gross, etc.

Table 1. Expendable and Durable Items List .

(1) ITEM NUMBER	(2) LEVEL	(3) NATIONAL STOCK NUMBER	(4) ITEM NAME, DESCRIPTION, CAGEC, AND PART NUMBER	(5) U/M
1	O	8040-00-877-9872	ADHESIVE (71984) RTV732-3OZTUBE 3 Ounce Tube	OZ
2	O	8040-00-664-4318	ADHESIVE: General Purpose, Type II (18876) 9995460 1 Pint Can	PT
3	O	8040-01-250-3969	ADHESIVE: Loctite (05972) 242	OZ
4	F	8040-01-129-7171	ADHESIVE: Loctite (05972) 620	OZ
5	O	8040-00-142-9823	ADHESIVE: Silicone Rubber (81349) MIL-A-46106	KIT
6	C	6850-00-181-7929 6850-00-181-7933 6850-00-181-7940	ANTIFREEZE: Permanent, Ethylene Glycol, Inhibited (81349) MILA46153 1 Gallon Bottle 5 Gallon Can 55 Gallon Drum	GAL GAL GAL
7	C	6850-00-174-1806	ANTIFREEZE: Permanent, Type: Arctic Grade (81349) MIL-A-11755 55 Gallon Drum	GAL
8	F	5340-00-450-5718	CAP SET: Protective, Dust and Moisture Seal (19207) 10935405	EA
9	O		CAULK: Strip (75037) 08578 60 Strips, 1 Foot Long Each, Black	EA
10	H	5350-00-584-5454	CLOTH: Abrasive, Emery, Fine (80204) ANSI B74.18 50-Sheet Package	EA
11	O	8030-00-597-5367	COMPOUND: Antiseize, High Temperature (73165) 51008 25 pound can	LB
12	O	8030-01-241-9727	COMPOUND: Caulking (21106) MORTITE B-2 90 Foot Roll	FT

Table 1. Expendable and Durable Items List - Continued.

(1) ITEM NUMBER	(2) LEVEL	(3) NATIONAL STOCK NUMBER	(4) ITEM NAME, DESCRIPTION, CAGEC, AND PART NUMBER	(5) U/M
13	C	6850-00-926-2275	COMPOUND: Cleaning, Windshield (81348) O-C-1901 16 Ounce Can	OZ
14	F		COMPOUND: Gasket Forming, Silicone (05972) 77MA 8 Ounce Tube	OZ
			(05972) 77C 13 Ounce Cartridge	OZ
15	F	8030-00-111-2762 8030-00-111-2763	COMPOUND: Sealing (05972) 29031 50 CC Bottle Box of 10 Bottles, 10 CC Each Bottle	CC CC
16	O	8030-01-392-3276	COMPOUND: Sealing: Dissimilar Metal Protection (71961) 6099 1 Gallon Can	GAL
17	O	8030-00-081-2286 8030-00-081-2327	COMPOUND: Sealing, Pipe (05972) 079-21 50 CC Bottle Box of 10 Bottles, 10 CC Each Bottle	CC CC
18	C	7930-00-282-9699	DETERGENT: General Purpose, Liquid (81348) P-D-220 1 Gallon Can	GAL
19	O	3439-00-255-9935	FLUX: Soldering (58536) A-A-51145 TY1 FORM A 1 Pound Can	LB
20	C	9140-00-286-5286 9140-00-286-5287 9140-00-286-5288 9140-00-286-5289	FUEL: Diesel, DF-1 Grade, Winter (81346) ASTM D 975 Bulk 5 Gallon Can 55 Gallon Drum, 16 Gage 55 Gallon Drum, 18 Gage	GAL GAL GAL GAL
21	C	9140-00-286-5294 9140-00-286-5295 9140-00-286-5296 9140-00-286-5297	FUEL: Diesel, DF-2 Grade (81346) ASTM D 975 Bulk 5 Gallon Can 55 Gallon Drum, 16 Gage 55 Gallon Drum, 18 Gage	GAL GAL GAL GAL

Table 1. Expendable and Durable Items List - Continued.

(1) ITEM NUMBER	(2) LEVEL	(3) NATIONAL STOCK NUMBER	(4) ITEM NAME, DESCRIPTION, CAGEC, AND PART NUMBER	(5) U/M
22	F		GREASE: Aircraft (81343) AMS-G-4343	
		9150-00-119-9291	2 Ounce Tube	OZ
		9150-00-269-8255	1.75 Pound Can	LB
23	C		GREASE: Automotive and Artillery, GAA (81349) M-10924	
		9150-01-197-7693	14 Ounce Cartridge (M-10924-B)	OZ
		9150-01-197-7688	1-1/4 Ounce Tube (M-10924-A)	OZ
		9150-01-197-7690	2-1/4 Pound Can (M-10924-C)	LB
		9150-01-197-7692	35 Pound Can (M-10924-E)	LB
		9150-01-197-7691	120 Pound Drum (M10924-F)	LB
24	O		GREASE: Silicone (53711) 5205453	
		9150-01-066-1823	Box of 12 tubes, 5.3 ounces each	OZ
25	O		GREASE: Molybdenum Disulfide (39428) 1062K97	
		9150-01-326-5424	14 Ounce Cartridge	OZ
26	C		OIL: Lubricating, OEA, Arctic (81349) MIL-L-46167	
		9150-00-402-4478	1 Quart Can	QT
		9150-00-402-2372	5 Gallon Can	GAL
		9150-00-491-7197	55 Gallon Drum	GAL
27	C		OIL: Lubricating, OE/HDO 10 (81349) MIL-L-2104	
		9150-00-189-6727	1 Quart Can	QT
		9150-00-186-6668	5 Gallon Can	GAL
		9150-00-191-2772	55 Gallon Drum, 18 Gage (MILL2104)	GAL
28	C		OIL: Lubricating, OE/HDO 15/40 (81349) MIL-L-2104	
		9150-01-152-4117	1 Quart Can	QT
		9150-01-152-4118	5 Gallon Can	GAL
		9150-01-152-4119	55 Gallon Drum	GAL
29	C		OIL: Lubricating, OE/HDO 30 (81349) MIL-L-2104	
		9150-00-186-6681	1 Quart Can	QT
		9150-00-188-9858	5 Gallon Can	GAL
		9150-00-189-6729	55 Gallon Drum	GAL
30	C		OIL: Lubricating, OE/HDO 40 (81349) MILL2104	
		9150-00-189-6730	1 Quart Can	QT
		9150-00-188-9862	55 Gallon Drum	GAL

Table 1. Expendable and Durable Items List - Continued.

(1) ITEM NUMBER	(2) LEVEL	(3) NATIONAL STOCK NUMBER	(4) ITEM NAME, DESCRIPTION, CAGEC, AND PART NUMBER	(5) U/M
31	C	9150-01-035-5390 9150-01-035-5391	OIL: Lubricating, GO 75 (81349) MIL-PRF-2105 1 Quart Can 5 Gallon Can	QT GAL
32	C	9150-01-035-5392 9150-01-313-2191 9150-01-035-5395 9150-01-035-5394	OIL: Lubricating, GO 80/90 (81349) MIL-PRF-2105 1 Quart Can 1 Gallon Can 5 Gallon Can 55 Gallon Drum	QT GAL GAL GAL
33	C	9150-01-048-4591 9150-01-035-5395 9150-01-035-5396	OIL: Lubricating, GO 85/140 (81349) MIL-PRF-2105 1 Quart Can 5 Gallon Can 55 Gallon Drum	QT GAL GAL
34	C	9150-01-410-8972	OIL: Lubricating, Refrigerant Compressor, Synthetic Ester (59595) CAPELLA HFG-68NA 1 Quart Can	QT
35	O	8010-01-141-3949	PAINT: Heat Resisting, White (87187) 1505 13 Ounce Can, Pressurized Spray	OZ
36	H	8010-01-329-6150	PASTE: Prussian Blue, Bearing Surface, Permatex (62377) 35V 2 Ounce Tube	OZ
37	H	9150-00-250-0926	PETROLATUM, TECHNICAL (81348) VV-P-236 1.75 Pound Can	LB
38	F	8040-01-024-6993	PRIMER: Adhesive (05972) 73656 6 Ounce Can	OZ
39	C	7920-00-205-1711	RAG: Wiping (64067) 7920-00-205-1711 50 Pound Bale	LB
40	O	3439-00-555-4629	SOLDER: Lead-tin Alloy, Rosin Core (81348) QQ-S-571 1 Pound Spool	LB

Table 1. Expendable and Durable Items List - Continued.

(1) ITEM NUMBER	(2) LEVEL	(3) NATIONAL STOCK NUMBER	(4) ITEM NAME, DESCRIPTION, CAGEC, AND PART NUMBER	(5) U/M
41	O		STRAP: Tiedown, Electrical Components Box of 100	EA
		5975-00-984-6582	(96906) MS3367-1-0 6 Inch Length, 1.75 Inch Maximum Bundle, Black	
		5975-00-935-5946	(96906) MS3367-2-1 13.35 Inch Length, 4 Inch Maximum Bundle, Brown	
		5975-00-903-2284	(96906) MS3367-4-0 4 Inch Length, Black	
42	O		TAG: Marker (64067) 9905-00-537-8954	
		9905-00-537-8954	Bundle of 50	EA
43	O		TAPE: Double-sided (7X678) 4970	YD
44	O		TAPE: Duct, 2 Inches Wide (39428) 1791K70	
		5640-00-103-2254	60 Yard Roll	YD
45	O		TAPE: Insulation, Electrical (75037) 33	
		5970-00-989-1485	260 Inch Roll	IN
46	F		TAPE: Insulation, Thermal 2 Inches Wide (73030) HS7495-618	
		5640-00-580-6276	30-Foot Length	FT
47	F		TETRAFLUOROETHANE: Technical, Refrigerant, R-134A Type (4V886) R134A	
		6830-01-439-0614	43-Pound Cylinder	LB
48	F	5180-00-754-0643	TOOL KIT: Body and Fender Repair (50980) SC5180-90-N34	EA
49	F	8305-01-301-1031	WIPES: Lint-free (28480) 92193W	EA
50	O		WIRE: Nonelectrical (81346) ASTM A641	
		9505-00-596-0191	5 Pound Coil	LB

END OF WORK PACKAGE



---

**TOOL IDENTIFICATION LIST**

---

**0313 00****SCOPE**

This work package lists all common tools and supplements and special tools/fixtures needed to maintain both models. ■

**EXPLANATION OF COLUMNS IN THE TOOL IDENTIFICATION LIST**

1. **Column (1) - Item Number (No.)**. This number is assigned to the entry in the list and is referenced in the initial setup to identify the item (e.g., Tool kit, general mechanic's, Item 102, WP 0313 00).
2. **Column (2) - Item Name**. This column lists the item by noun nomenclature and other descriptive features (e.g., PC Card, Transmission).
3. **Column (3) - National Stock Number**. This is the National Stock Number (NSN) assigned to the item; use it to requisition the item.
4. **Column (4) - Part Number/CAGEC**. Indicates the primary number used by the manufacturer (individual, company, firm, corporation or Government activity) which controls the design and characteristics of the item by means of its engineering drawings, specifications, standards, and inspection requirements to identify an item or range of items. The manufacturer's Commercial and Government Entity Code (CAGEC) is also included.
5. **Column (5) - Reference**. This column identifies the authorizing supply catalog or RPSTL for items listed in this work package.

TOOL IDENTIFICATION LIST - CONTINUED

0313 00

TOOL IDENTIFICATION LIST

Table 1. Tool Identification List.

(1) ITEM NO.	(2) ITEM NAME	(3) NATIONAL STOCK NUMBER	(4) PART NUMBER/ CAGEC	(5) REFERENCE
1	Adapter, Test, ABS	4910-01-372-3128	446 300 3140 (78500)	TM 9-2320-303-24P
2	Adapter, Torque Wrench	5120-01-493-9093	J38564 (33287)	TM 9-2320-303-24P
3	Adapter Kit, Mechanical Test	4940-01-353-7038	J 28593 (33287)	TM 9-2320-303-24P
4	Bar, Wrecking: 30 in length	5120-00-293-0665	55-130 (57068)	SC 4910-95-A72
5	Barring Tool, Engine	5120-01-322-3498	J36237 (33287)	TM 9-2320-303-24P
6	Bracket, Mounting	5340-01-475-3497	J41445 (33287)	TM 9-2320-303-24P
7	Bracket, Vehicular Components	2590-01-475-7886	J35926-A (33287)	TM 9-2320-303-24P
8	Bushing, Sleeve	3120-01-475-1603	J37041	TM 9-2320-303-24P
9	Caliper, Micrometer, Outside	5210-00-540-2973	T230RL (57163)	SC 4910-95-A02
10	Caps, Vise Jaw: 4 in.	5120-00-221-1506	A-A-2938 (58536)	SC 4910-95-A31
11	Clamp, C	5120-00-203-6431	534251 (08292)	SC 4910-95-A31
12	Compressor, Spring	5120-01-476-9379	J35924 (33287)	TM 9-2320-303-24P
13	Compressor, Spring	5120-01-476-9381	J41462 (33287)	TM 9-2320-303-24P
14	Compressor, Spring	5120-01-353-2522	J24203-3 (33287)	TM 9-2320-303-24P
15	Compressor Unit, Reciprocating	4310-00-752-9633	MIL-C-52980 (81349)	SC 4910-95-A74
16	Crowfoot Attachment Set, Socket	5120-01-429-1110	214FC (55719)	GSA Catalog
17	Cutter, Tube	4710-01-451-8753	PTC001 (93061)	GSA Catalog
18	Dial Indicator Set	5210-00-794-9178	J-05959-A (33287)	SC 4910-95-A31
19	Dispenser, Sealant	5120-00-061-1283	45RCT (88736)	SC 4910-95-A31
20	Drill, Electric, Portable: 3/8 in size	5130-00-935-7354	6635 (55111)	SC 4910-95-A74
21	Drill Set, Twist	5133-00-293-0983	800434 (19203)	SC 4910-95-A74
22	Driver, Bushing	5120-01-353-2521	PT 4365-1 (33287)	TM 9-2320-303-24P
23	Gage, Depth, Micrometer: 0-6 in. Range	5210-00-619-4045	52-225-015 (1E258)	GSA Catalog
24	Gage, Oil Level		99-431 (0W4A6)	GSA Catalog
25	Gage, Profile	5220-01-388-1460	J-38548-A (33287)	TM 9-2320-303-24P
26	Gage, Profile	5220-01-357-4913	TF-0237 (74410)	TM 9-2320-303-24P
27	Gloves, Chemical and Oil Protective: rubber	8415-00-641-4601	ZZ-G-381 (81348)	SC 4910-95-A74

Table 1. Tool Identification List.

(1) ITEM NO.	(2) ITEM NAME	(3) NATIONAL STOCK NUMBER	(4) PART NUMBER/ CAGEC	(5) REFERENCE
28	Gloves, Protective	8415-01-138-2495	PD412A-07878-37001 (1DBW0)	
29	Gloves, Welder's	8415-00-268-7859	A-A-50022 (58536)	SC 4910-95-A31
30	Goggles, Industrial	4240-00-052-3776	A-A-1110 (58536)	SC 4910-95-A74
31	Handle, Driver	5120-00-977-5578	J7079-2 (33287)	TM 9-2320-303-24P
32	Harness, Wiring	6150-01-354-2604	J 35751 (33287)	TM 9-2320-303-24P
33	Heat Gun	4940-01-037-7268	6966C (78976)	GSA Catalog
34	Holder, Clutch	5120-01-439-0305	99-499 (07BE6)	TM 9-2320-303-24P
35	Holding Bar, Pinion	5120-01-455-0436	J 3453-1 (33287)	TM 9-2320-303-24P
36	Indicator, Dial	5210-00-402-9619	J7872 (33287)	TM 9-2320-303-24P
37	Insertor, ABS Ring	5120-01-479-4986	107119 (4N501)	TM 9-2320-303-24P
38	Insertor and Remover	5120-01-476-9378	J37030-3 (33287)	TM 9-2320-303-24P
39	Insertor and Remover, Bearing and Bushing	5120-01-338-7182	J25447-B (33287)	TM 9-2320-303-24P
40	Insertor and Remover, Spring	5120-01-388-5623	J35923-2 (33287)	TM 9-2320-303-24P
41	Insertor, Bearing and Bushing	5120-01-475-7610	J39954 (33287)	TM 9-2320-303-24P
42	Insertor, Bearing and Bushing	5120-01-475-7608	J37033 (33287)	TM 9-2320-303-24P
43	Insertor, Bearing and Bushing	5120-01-476-9377	J37038 (33287)	TM 9-2320-303-24P
44	Insertor, Bearing and Bushing	5120-01-477-2749	J37040 (33287)	TM 9-2320-303-24P
45	Insertor, Bearing and Bushing	5120-01-475-7609	J39949 (33287)	TM 9-2320-303-24P
46	Insertor, Bearing and Bushing	5120-01-476-9380	J37036 (33287)	TM 9-2320-303-24P
47	Insertor, Seal	5120-01-492-7522	J37032 (33287)	TM 9-2320-303-24P
48	Insertor, Seal	5120-01-441-1065	J42381	
49	Insertor, Seal	5120-01-492-7521	J37031 (33287)	TM 9-2320-303-24P
50	Installer, Seal	5120-00-977-5579	J8550 (33287)	TM 9-2320-303-24P
51	Installer, Seal	5120-01-481-2193	8HE542 (45152)	TM 9-2320-303-24P
51.1	Installer, Slinger		J-46150 (33287)	TM 9-2320-303-24P
52	Jack, Hydraulic, Hand: 12 ton capacity	5120-00-224-7330	67224 (07505)	SC 4910-95-A74
53	Lathe, Brakedrum	4910-01-028-9849	4100 (4T928)	SC 4910-95-A31
54	Leak Detector, Refrigerant Gas	4940-01-387-0948	16500 (07295)	TM 9-2320-303-24P
55	Level, Digital		J 38460-A (33287)	TM 9-2320-303-24P

Table 1. Tool Identification List.

(1) ITEM NO.	(2) ITEM NAME	(3) NATIONAL STOCK NUMBER	(4) PART NUMBER/ CAGEC	(5) REFERENCE
56	Lift, Transmission and Differential	4910-00-585-3622	49 (79260)	SC 4910-95-A31
57	Lifting Bracket, Flywheel	5120-01-116-6049	J-24365 (33287)	TM 9-2320-303-24P
58	MSD/ICE	6625-01-493-8968	13580880 (18876)	TM 9-2320-303-24P
59	Multimeter	6625-01-265-6000	27 W/ACCE (89536)	SC 4910-95-A31
60	Multimeter, Digital	6625-01-139-2512	T00377 (55026)	SC 4910-95-A72
61	Multiplier, Torque Wrench	5120-00-169-2986	PD1201 (92059)	SC-4910-95-A31
62	Pan, Drain: 4 gallon capacity	4910-00-387-9592	450 (05463)	SC 4910-95-A74
63	Parts Kit, Valves	4810-01-477-1579	J-33163 (33287)	TM 9-2320-303-24P
64	PC Card, ABS	7025-01-482-9014	J-38500-1800A (33287)	TM 9-2320-303-24P
65	PC Card, CTIS/CWS	7025-01-482-8911	J-38500-1300E	TM 9-2320-303-24P
66	PC Card, Transmission	7025-01-482-8961	J38500-303 (33287)	TM 9-2320-303-24P
67	Pliers, Hose Clamp		J-38185	TM 9-2320-303-24P
68	Pliers, Retaining Ring: internal, 0.120 in. diameter, 3.15-6.5 in. ring diameter	5120-00-293-0186	7082060 (19207)	SC 4910-95-A31
69	Pliers, Retaining Ring: internal, 1.75 to 2 in. ring size	5120-00-293-0045	0300 (79136)	SC 4910-95-A31
70	Pliers, Slip Joint	5120-00-537-3375	18P	TM 9-2320-303-24P
71	Press, Arbor, Hand Operated	3444-00-449-7295	26A49 (79805)	SC 4910-95-A31
72	Puller Kit, Universal	5180-00-313-9496	1178 (45225)	SC 4910-95-A72
73	Puller Kit, Universal	5180-00-423-1596	1677SPECIAL (45225)	SC 4910-95-A31
74	Puller Kit, Universal	5180-01-048-2153	J24171A (33287)	TM 9-2320-303-24P
75	Reclaimer, Refrigerant	4250-01-396-8928	EEAC304 (55719)	GSA Catalog
75.1	Remover, Seal	5180-01-048-2153	J24171-A (33287)	TM 9-2320-303-24P
76	Remover, Wheel Bearing Cup	5120-00-784-6482	J3940 (33287)	TM 9-2320-303-24P
77	Ring, Retaining	5325-01-475-4635	J37030-1 (33287)	TM 9-2320-303-24P
78	Ring Retaining	5325-01-475-4745	J37030-2 (33287)	TM 9-2320-303-24P
79	Riveter, Blind, Hand	5120-00-017-2849	98 (54402)	SC 4910-95-A74
80	Scale	4910-00-707-9178	J-00544-A (33287)	TM 9-2320-303-24P
81	Shop Equipment, Automotive Vehicle	4910-00-754-0705	SC 4910-95CLA31	
82	Shop Equipment, Automotive Vehicle	4910-00-348-7696	SC 4910-95CLA02	
83	Shop Equipment, Automotive Vehicle	4910-00-754-0706	SC 4910-95CLA62	
84	Slider, Spring Compressor	4910-01-165-6015	TFTLN-2500 (74410)	TM 9-2320-303-24P

Table 1. Tool Identification List.

(1) ITEM NO.	(2) ITEM NAME	(3) NATIONAL STOCK NUMBER	(4) PART NUMBER/ CAGEC	(5) REFERENCE
85	Sling, Beam Type	3940-01-353-8561	J-39520 (33287)	GSA Catalog
86	Sling, Nylon	2835-01-078-2081	4-8FTx2IN (91796)	GSA Catalog
87	Socket, Socket Wrench	5130-01-389-8450	BWD482 (55719)	TM 9-2320-303-24P
88	Socket, Socket Wrench	5120-01-322-1123	J36003-A (33287)	TM 9-2320-303-24P
89	Socket, Socket Wrench	5120-01-478-8622	J39534 (33287)	TM 9-2320-303-24P
90	Soldering Gun	3439-00-618-6623	D550-3 (97049)	SC 4910-95-A74
91	Spanner		5229	TM 9-2320-303-24P
92	SPORT/ICE	6625-01-445-0085	13580703 (18876)	TM 9-2320-303-24P
93	Spreader, Sling	3940-01-354-9446	J39517 (45225)	TM 9-2320-303-24P
94	Stripper, Wire, Hand	5110-01-355-0848	J35615 (33287)	TM 9-2320-303-24P
95	Switch, Pressure	5930-01-475-0242	J33884-A (33287)	TM 9-2320-303-24P
96	Tape, Measuring: 50 feet long	5210-00-554-7085	403 (37163)	SC 4910-95-A72
97	Test Set	6685-01-438-5088	J38509 (33287)	
98	Tester, Power Steering	4910-01-160-3618	J26487-C (33287)	TM 9-2320-303-24P
99	Tester, PRO-LINK Diagnostic Reader	4910-01-343-3508	J 38500-H (33287)	TM 9-2320-303-24P
100	Tester, Kingpin Lock	4910-01-157-3571	TFTLN-5001 (74410)	TM 9-2320-303-24P
101	Tool Kit, Electrical Connector Repair	5180-00-876-9336	7550526 (19204)	SC 4910-95-A72
102	Tool Kit, General Mechanic's: Automotive	5180-01-481-8389	SC5180-90-N26 (50980)	SC 5180-95-N26
103	Tool Kit, Metal Worker's	5180-00-596-1510	SC5180-90-CL-N19	SC5180-90-CL-N19
104	Tool Kit, Transmission	5180-01-476-2361	J-37035 (33287)	
105	Trestle, Hoist, Portable: 7 ton capacity	3950-00-251-8013	306 (79805)	SC 4910-95-A72
106	Vise, Machinist's	5120-00-293-1439	504M2 (79416)	SC 4910-95-A74
107	Wrench, Strap	5120-00-020-2947	2432097 (10001)	SC 4910-95-A74
108	Wrench, Torque: 3/8 in drive, 0-200 lb-in capacity	5120-00-853-4538	F200I (90947)	SC 4910-95-A72
109	Wrench, Torque: 3/8 in drive, 0-300 lb-in capacity	5120-00-776-1841	2163993 (10001)	SC 4910-95-A74
110	Wrench, Torque: 3/8 in drive, 15-75 lb-ft capacity	5120-01-355-1734	QC2FR75 (55719)	SC 4910-95-A74
111	Wrench, Torque: 50-250 lb-ft capacity	5120-01-042-0982	VB-2503MFR (27464)	SC 4910-95-A74

Table 1. Tool Identification List.

(1) ITEM NO.	(2) ITEM NAME	(3) NATIONAL STOCK NUMBER	(4) PART NUMBER/ CAGEC	(5) REFERENCE
112	Wrench, Torque: 3/4 in drive, 100-600 lb-ft capacity	5120-01-113-9564	7379 (45225)	SC 4910-95-A72
113	Wrench Set, Socket: 3/4 in drive	5120-00-204-1999	FEDSTD353 (06542)	SC 4910-95-A72
114	Wrench Set, Socket Attachment: screwdriver, torx, 1/4 and 3/8 in drive	5120-01-178-6342	J-29843 (33287)	GSA Catalog

END OF WORK PACKAGE

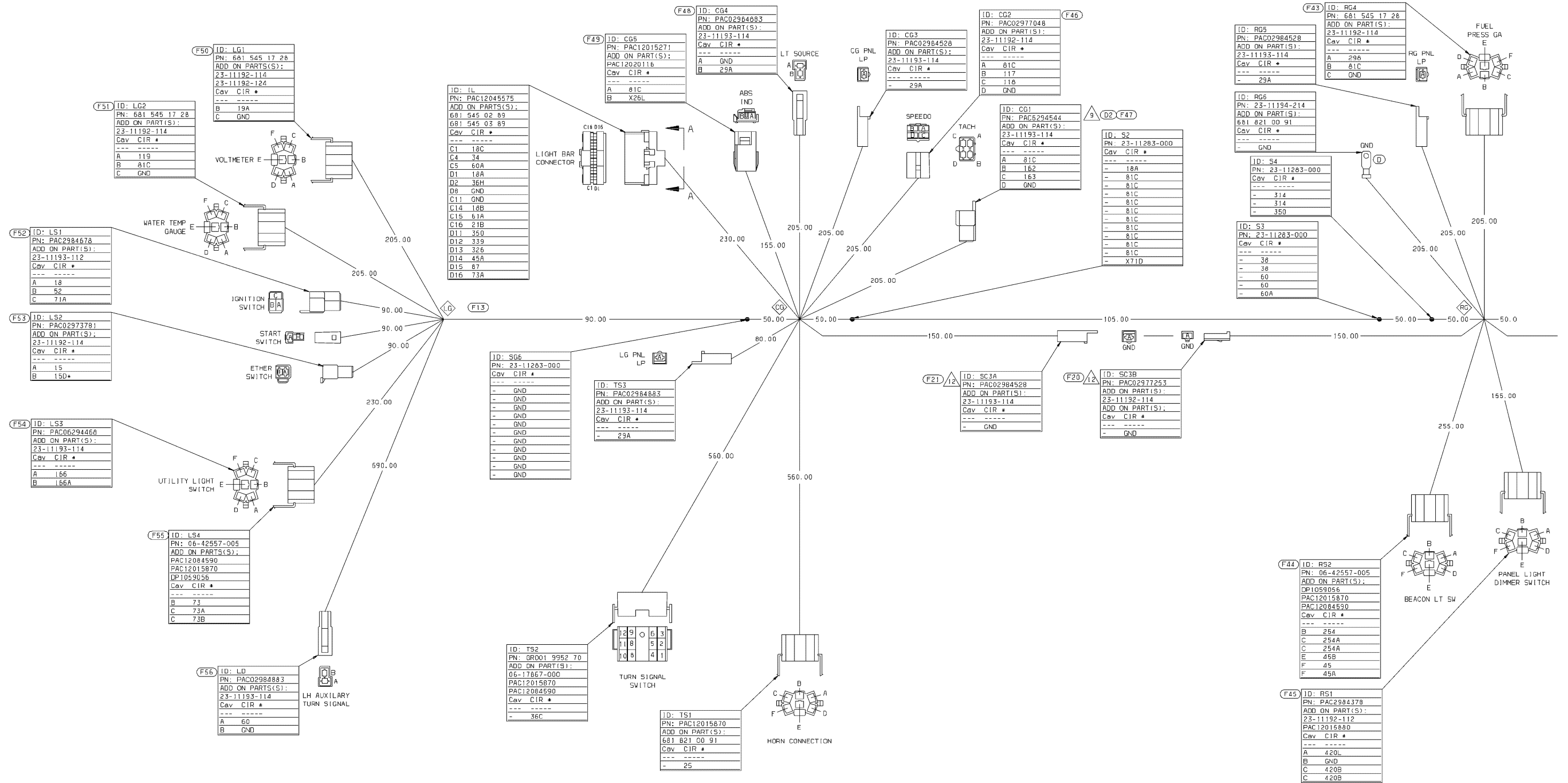









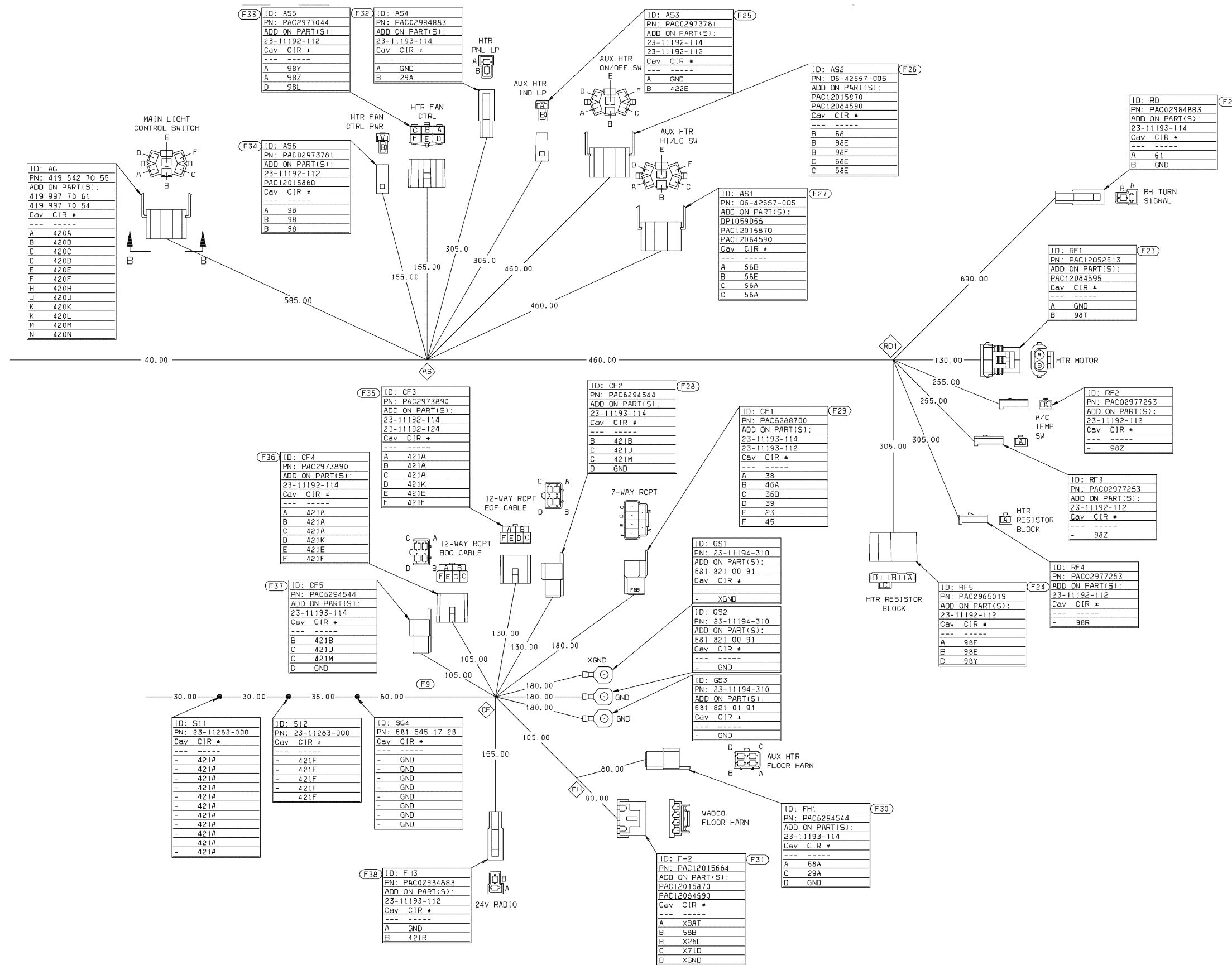

REV#	DATE	BY	DESCRIPTION	APP#	DATE	BY
PRE126-13	D	0311	ADD CORR 162 & 163	WUS	09/02/98	RAJ
PRE390-81	E	0117	ADD 119 ADDS TO BEFALL	REB	07/26/98	CAC
PRE409-92	F	0117	DEL 153 98L 98E	ALA	12/15/98	VEN
			F1110: 814 BALANCE VMS 814			
			C1111: DEL BAL SWL 30E			
			R1111: DEL LPA			
			F1112: DEL GND OF 91 SP10C			
			C1113: ADD NOTE 12			
			E1114: ADD NOTE 12			
			E1115: ADD NOTE 12			
			E1116: ADD NOTE 12			
			E1117: ADD NOTE 12			
			E1118: ADD NOTE 12			
			E1119: ADD NOTE 12			
			E1120: ADD NOTE 12			
			E1121: ADD NOTE 12			
			15-56: DEL NOTE 3 THROUGHOUT			

**FREIGHTLINER**  
LLC

THE INFORMATION CONTAINED HEREIN IS PROPRIETARY DATA AND IS NOT TO BE REPRODUCED OR TRANSMITTED IN ANY FORM OR BY ANY MEANS, ELECTRONIC OR MECHANICAL, INCLUDING PHOTOCOPYING, RECORDING, OR BY ANY INFORMATION STORAGE AND RETRIEVAL SYSTEM, WITHOUT THE WRITTEN PERMISSION OF FREIGHTLINER LLC.

DATE: 04/03/98  
BY: S. BRIGHT  
CHECKED BY: S. BRIGHT  
REVISIONS: 04/03/98  
APPROVED BY: S. BRIGHT  
DATE: 04/03/98  
BY: S. BRIGHT

DATE: 04/03/98  
BY: S. BRIGHT  
CHECKED BY: S. BRIGHT  
REVISIONS: 04/03/98  
APPROVED BY: S. BRIGHT  
DATE: 04/03/98  
BY: S. BRIGHT

HARN-DASH, MN, GVG, BASIC  
MILITARY BASIC HARN 915/916 & 917  
A06-28950







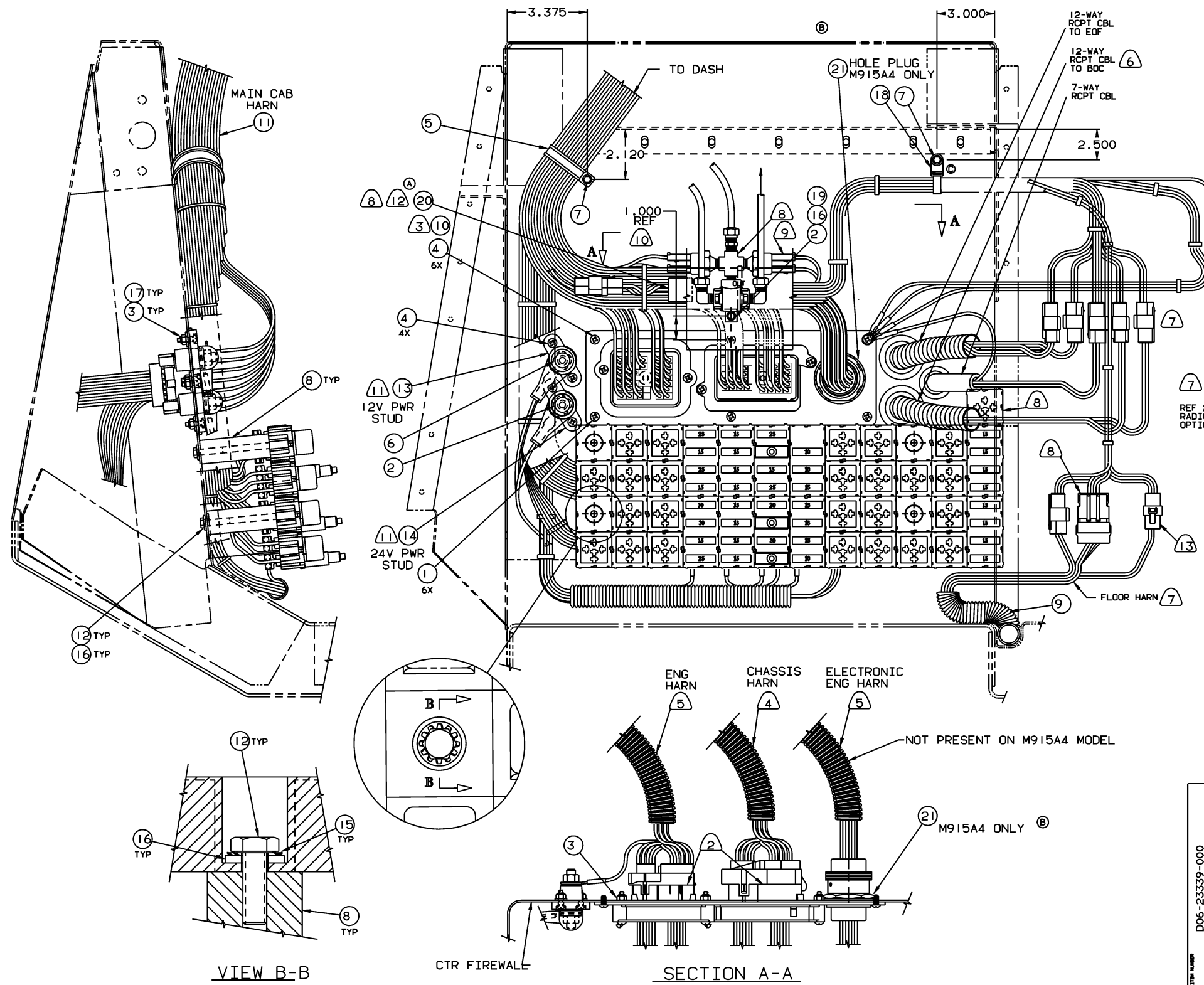

RELEASE NUMBER	ZONE	REVISION DESCRIPTION	BY	DATE	APPD
PB1048-10	-	INITIAL RELEASE	DJP	06/14/95	R.B
P2335-1-05	A	ADDED REF 20 & CHG DELTA 12.	GBJ	05/22/96	KVM
B10292-4A	B 4A	ADDED REF 21 (HOLE PLUG)	JRT	08/24/98	JLT
H50636-1A	C 2C	ADDED NOTE 13	GPH	04/26/00	CAC

- 1 ROUTE AND CLAMP WIRING TO AVOID CHAFING.
- 2 APPLY ELECTRICAL SEALANT GREASE 48-02439-000 INTO CONNECTORS FOR WEATHER RESISTANT SEAL.
- 3 APPLY 48-02454-206 SEALANT BETWEEN ITEM 21 PLATE AND FIREWALL.
- 4 SEE SPEC MODULE 288 FOR CHASSIS HARN.
- 5 SEE SPEC MODULE 286 FOR ENG HARN.
- 6 SEE SPEC MODULE 296/297 FOR 7-WAY AND 12-WAY TRLR RCPT.
- 7 ROUTING SHOWN OUT OF POSITION FOR CLARITY ONLY. INSTALL WIRING AND CONNECTORS INSIDE OF ELECTRICAL CENTER.
- 8 THIS IS AN OPTIONAL COMPONENT AND MAY NOT BE PRESENT FOR ALL MODELS. SEE VEHICLE SPEC FOR SPECIFIC PART NUMBERS AND CALLOUTS.
- 9 REF. CIRCUIT X30 AND GND FOR ABS DEEP CYCLE (IF PRESENT).
- 10 REF. CIR 87\* AND 81C FOR AXLE LOCK PRESS SW (916/917 ONLY). FOR 915 THE PRESS SWITCH IS MOUNTED BEHIND THE AG PANEL AND A JUMPER HARN IS USED. SEE VEHICLE SPEC.
- 11 APPLY 48-00118-002 SEALANT BETWEEN TERMINAL BLOCK AND FIREWALL.
- 12 SEE SPEC MODULE 148.
- 13 SEE SPEC MODULE 311 FOR DRL FLOOR HARNESS CALLOUT.

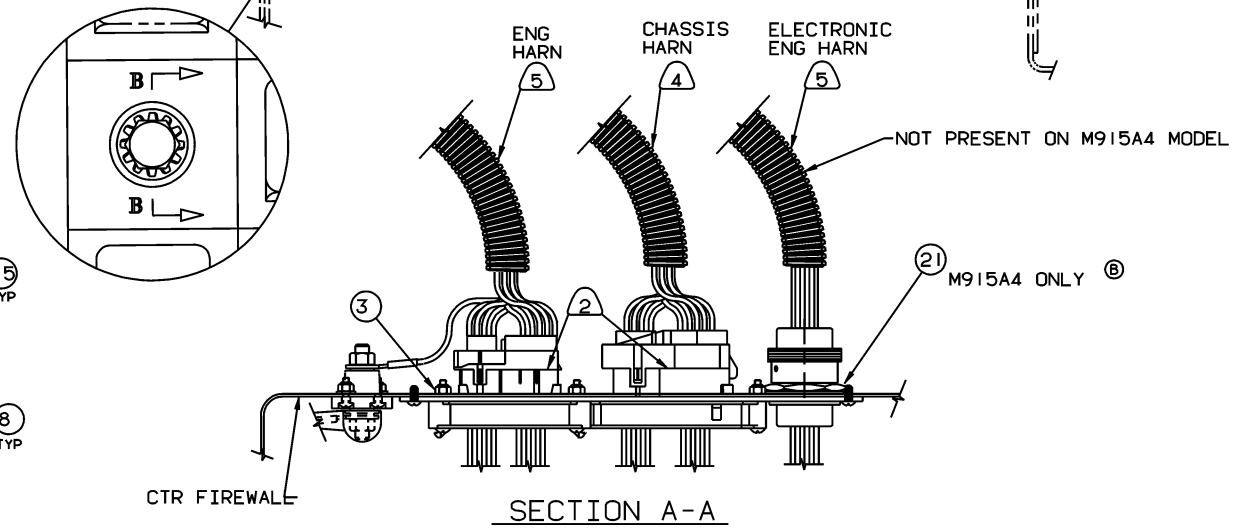
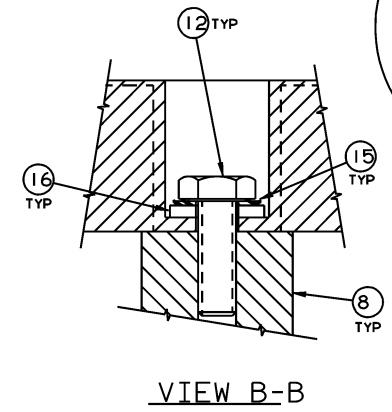

<b>FREIGHTLINER LLC</b>	
THE INFORMATION CONTAINED HEREIN IS PROPRIETARY DATA, AND IS NOT FOR DISSEMINATION OR DISCLOSURE, IN WHOLE OR IN PART, FOR ANY PURPOSE OTHER THAN THAT FOR WHICH IT IS SUBMITTED, EXCEPT AS AUTHORIZED IN WRITING BY FREIGHTLINER LLC.	
MATERIAL APPROVAL	DATE
DRAWN BY DJ PHILLIPS	DATE 06/14/95
CHECKED BY RJB	DATE 06/15/95
RESPONSIBLE ENGINEER DJP	DATE 06/15/95
APPROVED BY KVM	DATE 06/15/95
RESPONSIBLE MFG. ENGR. M. PLINCOCHAR	DATE 05/05/00
DESCRIPTION <b>INSTL-ELEC CTR, MAIN CAB</b>	
SUPPLEMENTARY DESCRIPTION 320A1 CAB 915/916/917 US ARMY	
FORMING NUMBER <b>D06-23339</b>	REVISION LETTER <b>C</b>
ITEM NUMBER <b>D06-23339-000</b>	SHEET NUMBER <b>1 OF 1</b>





Table with columns: F/L CIR NO, SAE CIR NO, WIRE ITEM NO, FROM LOC, TO LOC, APPROX LENGTH -000, CIRCUIT DESCRIPTION. Includes circuit descriptions like PWR MAIN ELEC CTR SPLY BUSSBAR1, START SIG SW OUTPUT, and LOW AIR PRESS WRN SIG.

A17, A16, A15

Table with columns: F/L CIR NO, SAE CIR NO, WIRE ITEM NO, FROM LOC, TO LOC, APPROX LENGTH -000, CIRCUIT DESCRIPTION. Includes circuit descriptions like <OLD>IGN ACCESS MISC SPLY AUX LTS, H, <OLD>MIRROR HEAT SW SPLY, and <OLD>TRAILER 7-WAY SPLY, RH EOC.

B2, B1, B0

Table with columns: F/L CIR NO, SAE CIR NO, WIRE ITEM NO, FROM LOC, TO LOC, APPROX LENGTH -000, CIRCUIT DESCRIPTION. Includes circuit descriptions like BEACON IND LP SIG, <OLD>OPTL PWR WIRE, CAB, and <OLD>TRAILER 24V MAIN PWR SPLY.

A22, A21, A20



F/L CIR NO	SAE CIR NO	WIRE ITEM NO	LOC	FROM	TO	APPROX LENGTH -000	CIRCUIT DESCRIPTION
421M	1316	25	CF4	50 - C	EBL1 /3\ - 87	1465	<OLD>TRAILER RH STOP LP 24V LP SPLY
421P	1321	25	EBM7	18 - B	BHC 18 - B4	1130	<OLD>BLACKOUT DRIVE LP 24V
421R	2001	26	FH7	51 - B	EBG4 11 - Y	1305	<OLD>RADIO 24V SPLY
421S	1424	24	BHC	18 - F4	EBG3 10 - Y	850	CHEMICAL DETECTOR 24V SPLY
421T	1424	25	FH8	46 - B	BHC 18 - F1	655	CHEMICAL DETECTOR ALARM SIG
421V	1321	25	EBG5	10 - X	EBK7 20 - 30	280	<OLD>BLACKOUT MAIN 24V SPLY
421V	1321	25	EBL7	20 - 30	EBK7 /3\ - 30	150	<OLD>BLACKOUT MAIN 24V SPLY
421V	1321	25	EBL7	/3\ - 30	EBM7 18 - 30	150	<OLD>BLACKOUT MAIN 24V SPLY
421W	1101	22	PS3	159 30 -	EBG8 4 7 Y	1140	<OLD>24V MAIN PWR FEED
421W	1101	22	PS3	159 30 -	EBG4 2 6 X	1150	<OLD>24V MAIN PWR FEED
421X	1424	25	FH8	46 - A	BHC 18 - G1	655	CHEMICAL DETECTOR ALARM RET
422	2304	26	EBG7	19 - X	S13 33 - 29	240	<OLD>HTR SW 24V PWR SPLY
422	2304	26	EBL5	19 - 30	S13 /3\ /3\ - 150	150	<OLD>HTR SW 24V PWR SPLY
422	2304	26	EBM5	19 - 30	S13 /3\ /3\ - 150	150	<OLD>HTR SW 24V PWR SPLY
422A	2304	26	BHE	15 - E4	S13 /3\ /3\ - 1120	1120	<OLD>HTR 24V PWR SPLY
422B	2304	26	BHE	15 - E3	EBM5 19 - 87	1200	<OLD>HTR 24V RUN PWR SPLY
422C	2304	26	BHE	15 - E2	EBL5 19 - 87	1160	<OLD>HTR 24V HIGH PWR SPLY
422E	2304	26	BHE	15 - E1	AS3 47 - B	1240	<OLD>HTR IND LP SIG
444	2105	24	EBF8	11 - X	EVT 43 - D	850	DDS ECU IGN PWR SPLY
444K	2105	24	EBH4	10 - X	EVT 43 - E	890	DDS RH SIDE SNR DISPLAY PWR SPLY
445A	2401	25	BHC	13 - D5	S26 33 29 - 460	460	BODY LK IND LP SIG
445A	2401	25	CG4	43 - A	S26 /3\ /3\ - 720	720	BODY LK IND LP SIG
445A	2401	25	EDC0	18 - 85	S26 /3\ /3\ - 670	670	BODY LK IND LP SIG
445B	2401	25	BHC	13 - D6	CG5 43 - A	1200	BODY UP IND LP SIG
446F	2109	23	EBG0	10 - X	EBJ0 17 - 30	360	TIRE INFLATE-CTIS, IGN RLY CONT SPLY
448	2402	25	EBF8	/3\ - X	EBM3 20 - 30	440	TAIL GATE CTRL PWR SPLY
448	2402	25	CF8	43 - A	EBM3 /3\ - 30	1430	TAIL GATE CTRL PWR SPLY
448E	2402	25	FH1	13 - A	FRM3 18 - 87A	1545	TAIL GATE PWR INTERRUPT RLY COIL SIG
448G	2402	25	CF8	43 - B	EBM3 18 - 86	1430	TAIL GATE CAB SW DSBLS SIG
497A	1803	23	CC1	12 - A	IL 44 - C2	1840	CHECK TRANS
497B	1803	23	CC1	12 - E	EBM0 17 - 86	1840	RVS WARNING
497C1	1803	23	V1V	105 - 4	EBD0 17 - 85	1530	TRANS TCU OUTPUT #1
497C2	1803	23	V1V	105 - 5	EBE0 17 - 86	1530	TRANS TCU OUTPUT #2
497C8	1803	23	CC2	106 - D	S11 33 29 - 660	660	TRANS TCU OUTPUT #8
497D3	1803	24	V1V	105 - 2	AG11 18 - 3	2230	TRANS TCU INPUT #3
497D12	1803	23	V1V	105 - 12	AG1 102 - F	1460	TRANS TCU INPUT #12
497D12	1803	23	AG2	17 - F	AG1 /3\ - F	200	TRANS TCU INPUT #12
497F	1803	23	CC2	106 - E	EBM1 17 - 85	1760	TRANS NEUT START
497K	1803	23	CC2	106 - F	S29 33 29 - 1230	1230	TRANS SP SIG
497K	1803	23	CG12	45 - A	S29 /3\ /3\ - 600	600	TRANS SP SIG
497K	1803	23	EV2	107 - A	S29 /3\ /3\ - 760	760	TRANS SP SIG
1587+A	1601	137	DC1	12 - B	FH5 43 - D	1995	DATABUS, POS, ANTILK BRAKE
1587-A	1601	136	DC1	12 - G	FH5 43 - C	1995	DATABUS, NEG, ANTILK BRAKE
1587+T	1601	137	DC1	12 - C	CC1 12 - D	2145	DATABUS, POS, TRANS SYSTEM
1587-T	1601	136	DC1	12 - F	CC1 12 - C	2145	DATABUS, NEG, TRANS SYSTEM
1587+W	1601	137	DC2	12 - C	EVT 43 - G	1675	DATABUS, POS, OBSTACLE DETECTION SYS
1587-W	1601	136	DC2	12 - D	EVT 43 - H	1675	DATABUS, NEG, OBSTACLE DETECTION SYS
X26L	1601	24	FH3	18 - B	CG7 43 - B	1620	ABC IND LAMP
X71D	1601	24	FH3	18 - C	S2 /3\ /3\ - 1310	1310	ABS-IGN FEED
XB87	1701	27	FH3	19 - A	EBE1 11 - Y	1240	<OLD>ABS ECU ABS PWR SPLY
GND1	1204	25	GS1	86 28 -	SG1 153 29 - 1090	1090	GND, GENERAL 1
GND1	1204	23	EBK1	17 - 86	SG1 /3\ /3\ - 150	150	GND, GENERAL 1
GND1	1204	23	EBK3	17 - 86	SG1 /3\ /3\ - 150	150	GND, GENERAL 1
GND1	1204	23	EBK7	17 - 86	SG1 /3\ /3\ - 150	150	GND, GENERAL 1
GND1	1204	23	EBB7	17 - 86	SG1 /3\ /3\ - 200	200	GND, GENERAL 1
GND1	1204	23	EBA7	17 - 86	SG1 /3\ /3\ - 240	240	GND, GENERAL 1
GND1	1204	23	EBB3	17 - 86	SG1 /3\ /3\ - 150	150	GND, GENERAL 1
GND1	1204	23	EBB1	17 - 86	SG1 /3\ /3\ - 160	160	GND, GENERAL 1
GND1	1204	23	EBK0	17 - 86	SG1 /3\ /3\ - 200	200	GND, GENERAL 1
GND1	1204	23	EBD0	17 - 86	SG1 /3\ /3\ - 160	160	GND, GENERAL 1
GND1	1204	23	EBF0	17 - 86	SG1 /3\ /3\ - 200	200	GND, GENERAL 1
GND1	1204	23	EBG0	17 - 86	SG1 /3\ /3\ - 240	240	GND, GENERAL 1
GND1	1204	23	EBG0	17 - 30	SG1 /3\ /3\ - 240	240	GND, GENERAL 1
GND2	1204	26	GS1	86 28 -	SG2 153 29 - 1450	1450	GND, GENERAL 2
GND2	1204	23	EBK3	17 - 86	SG2 /3\ /3\ - 150	150	GND, GENERAL 2
GND2	1204	23	EBL1	17 - 86	SG2 /3\ /3\ - 150	150	GND, GENERAL 2
GND2	1204	23	EBL3	17 - 86	SG2 /3\ /3\ - 150	150	GND, GENERAL 2
GND2	1204	23	EBM1	17 - 86	SG2 /3\ /3\ - 150	150	GND, GENERAL 2
GND2	1204	23	EBM6	17 - 86	SG2 /3\ /3\ - 150	150	GND, GENERAL 2
GND2	1204	23	EBL5	17 - 86	SG2 /3\ /3\ - 150	150	GND, GENERAL 2
GND2	1204	23	EBM7	17 - 86	SG2 /3\ /3\ - 160	160	GND, GENERAL 2
GND2	1204	23	EBL7	17 - 86	SG2 /3\ /3\ - 150	150	GND, GENERAL 2
GND2	1204	23	EBK7	17 - 86	SG2 /3\ /3\ - 150	150	GND, GENERAL 2
GND2	1204	23	EBK5	17 - 86	SG2 /3\ /3\ - 150	150	GND, GENERAL 2
GND2	1204	23	EBJ7	17 - 30	SG2 /3\ /3\ - 160	160	GND, GENERAL 2
GND2	1204	23	EB17	17 - 86	SG2 /3\ /3\ - 200	200	GND, GENERAL 2
GND2	1204	23	EB17	17 - 30	SG2 /3\ /3\ - 200	200	GND, GENERAL 2
GND2	1204	23	EB13	17 - 86	SG2 /3\ /3\ - 160	160	GND, GENERAL 2
GND2	1204	24	EBJ0	17 - 86	SG2 /3\ /3\ - 200	200	GND, GENERAL 2
GND2	1204	24	EBK0	17 - 86	SG2 /3\ /3\ - 160	160	GND, GENERAL 2
GND2	1204	24	EBL0	17 - 86	SG2 /3\ /3\ - 150	150	GND, GENERAL 2
GND3	1204	26	GS1	86 28 -	SG3 /3\ /3\ - 1470	1470	GND, GENERAL 3
GND3	1204	24	CG2	50 - D	SG3 /3\ /3\ - 280	280	GND, GENERAL 3
GND3	1204	24	CG10	50 - A	SG3 /3\ /3\ - 280	280	GND, GENERAL 3
GND3	1204	24	CG12	46 - C	SG3 /3\ /3\ - 280	280	GND, GENERAL 3
GND3	1204	23	IL	44 - D8	SG3 /3\ /3\ - 300	300	GND, GENERAL 3
GND3	1204	24	LG2	46 - C	SG3 /3\ /3\ - 340	340	GND, GENERAL 3
GND3	1204	24	LG3	46 - C	SG3 /3\ /3\ - 340	340	GND, GENERAL 3
GND3	1204	25	LG4	83 28 -	SG3 /3\ /3\ - 340	340	GND, GENERAL 3
GND3	1204	25	LD2	50 - B	SG3 /3\ /3\ - 845	845	GND, GENERAL 3
GND3	1204	142	LD3	141 - C	SG3 /3\ /3\ - 845	845	GND, GENERAL 3
GND3	1204	24	DC3	43 - B	SG3 /3\ /3\ - 525	525	GND, GENERAL 3
GND3	1204	25	TS1	18 - L	SG3 /3\ /3\ - 720	720	GND, GENERAL 3
GND4	1204	26	GS1	86 28 -	SG4 153 29 - 1110	1110	GND, GENERAL 4
GND4	1204	25	RG1	83 28 -	SG4 /3\ /3\ - 330	330	GND, GENERAL 4
GND4	1204	24	RG3	46 - C	SG4 /3\ /3\ - 330	330	GND, GENERAL 4
GND4	1204	24	RG4	46 - C	SG4 /3\ /3\ - 330	330	GND, GENERAL 4
GND4	1204	24	RG5	46 - C	SG4 /3\ /3\ - 330	330	GND, GENERAL 4
GND4	1204	25	RS2R	18 - E	SG4 /3\ /3\ - 390	390	GND, GENERAL 4

F/L CIR NO	SAE CIR NO	WIRE ITEM NO	LOC	FROM	TO	APPROX LENGTH -000	CIRCUIT DESCRIPTION	
GND4	1204	25	RS2L	18 - E	SG4 /3\ /3\ - 390	390	GND, GENERAL 4	
GND4	1204	26	RS3	47 - B	SG4 /3\ /3\ - 280	280	GND, GENERAL 4	
GND4	1204	23	LF6	45 - A	SG4 /3\ /3\ - 1100	1100	GND, GENERAL 4	
GND4	1204	25	OH	50 - A	SG4 /3\ /3\ - 1350	1350	GND, GENERAL 4	
GND4	1204	25	OH1	46 - A	SG4 /3\ /3\ - 1350	1350	GND, GENERAL 4	
GND4	1204	25	AG10	46 - A	SG4 /3\ /3\ - 1050	1050	GND, GENERAL 4	
GND4	1204	25	AS1	50 - C	SG4 /3\ /3\ - 740	740	GND, GENERAL 4	
GND4	1204	24	AS8	91 - B	SG4 /3\ /3\ - 1210	1210	GND, GENERAL 4	
GND4	1204	23	AG11	17 - B	SG4 /3\ /3\ - 1210	1210	GND, GENERAL 4	
GND5	1204	26	GS1	86 28 -	SG5 33 29 - 960	960	GND, GENERAL 5	
GND5	1204	25	RD2	50 - B	SG5 /3\ /3\ - 1750	1750	GND, GENERAL 5	
GND5	1204	142	RD3	141 - C	SG5 /3\ /3\ - 1750	1750	GND, GENERAL 5	
GND5	1204	25	W43	134 156 A	SG5 /3\ /3\ - 1220	1220	GND, GENERAL 5	
GND5	1204	25	W44	135 - A	SG5 /3\ /3\ - 3020	3020	GND, GENERAL 5	
GND5	1204	23	EB21	147 132 A	SG5 /3\ /3\ - 550	550	GND, GENERAL 5	
GND5	1204	24	EB23	108 132 F	SG5 /3\ /3\ - 660	660	GND, GENERAL 5	
GND5	1204	24	BHC	12 - C5	SG5 /3\ /3\ - 480	480	GND, GENERAL 5	
GND5	1204	24	BHE	14 - A4	SG5 /3\ /3\ - 590	590	GND, GENERAL 5	
GND6	1204	25	GS2	85 28 -	SG6 33 29 - 450	450	GND, GENERAL 6	
GND6	1204	25	CF1	50 - D	SG6 /3\ /3\ - 350	350	GND, GENERAL 6	
GND6	1204	25	CF4	50 - D	SG6 /3\ /3\ - 365	365	GND, GENERAL 6	
GND6	1204	25	FH2	50 - D	SG6 /3\ /3\ - 420	420	GND, GENERAL 6	
GND6	1204	24	FH4	43 - A	SG6 /3\ /3\ - 470	470	GND, GENERAL 6	
GND6	1204	24	BHC	18 - G4	SG6 /3\ /3\ - 350	350	GND, GENERAL 6	
GND6	1204	24	EVT	43 - F	SG6 /3\ /3\ - 750	750	GND, GENERAL 6	
GND8	1204	27	RF1	103 146 A	GS2 86 28 - 1930	1930	GND, GENERAL 8	
GND9	1204	26	FH7	51 - A	GS2 86 28 - 795	795	GND, GENERAL 9	
XGND	1206	27	FH8	19 - D	GS2 86 28 - 780	780	<OLD>ABS ECU ABS GND	
GND+	1204	24	EBG0	18 - 87A	SG+ 33 29 - 1020	1020	GND, GENERAL CAB/CHASSIS	
GND+	1204	24	AS3	46 - A	SG+ /3\ /3\ - 800	800	GND, GENERAL CAB/CHASSIS	
GND+	1204	23	CG4	106 - B	SG+ /3\ /3\ - 520	520	GND, GENERAL CAB/CHASSIS	
GND+	1204	23	CG5	106 - B	SG+ /3\ /3\ - 520	520	GND, GENERAL CAB/CHASSIS	
GND+	1204	23	CG6	106 - B	SG+ /3\ /3\ - 520	520	GND, GENERAL CAB/CHASSIS	
GND+	1204	23	CG9	106 - B	SG+ /3\ /3\ - 520	520	GND, GENERAL CAB/CHASSIS	
89	34	1409	23	LF7	45 - A	IL 44 - C4	1680	DIL PRESS LAMP SIG
810	GND4	1204	23	LF8	45 - A	SG4 /3\ /3\ - 1100	1100	GND, GENERAL 4
83	497Y	1803	23	AG1	102 - E	AG2 102 - E	200	TRANS DIGITAL RTN
83	497Y	1803	23	AG1	/3\ - E	V1V 105 - 13	1970	TRANS DIGITAL RTN

- 13. REF SAME LOCATION IN TWO SEPARATE VIEW'S ZONE F19 (SHEET 2) AND ZONE F8 (SHEET 1).
- 14. APPLY TIE STRAPS AND/OR VINYL TAPE AS NECESSARY TO SECURE CONDUIT.
- 15. CONDUIT MUST BE FLOATING
- 16. SECURE 'J19' TO 'BHE' BREAKOUT
- 17. MAINTAIN ADEQUATE CLEARANCE FOR 1" DIAMETER ALUMINIUM MOUNTING POST (4 PLACES)
- 18. HANK VIPER MOTOR BREAKOUT (WV4)
- 19. THE 18 LEADS SPECIFIED AT SPLICE SG2 IS APPROVED BY FREIGHTLINER
- 20. 90° BEND REQUIRED

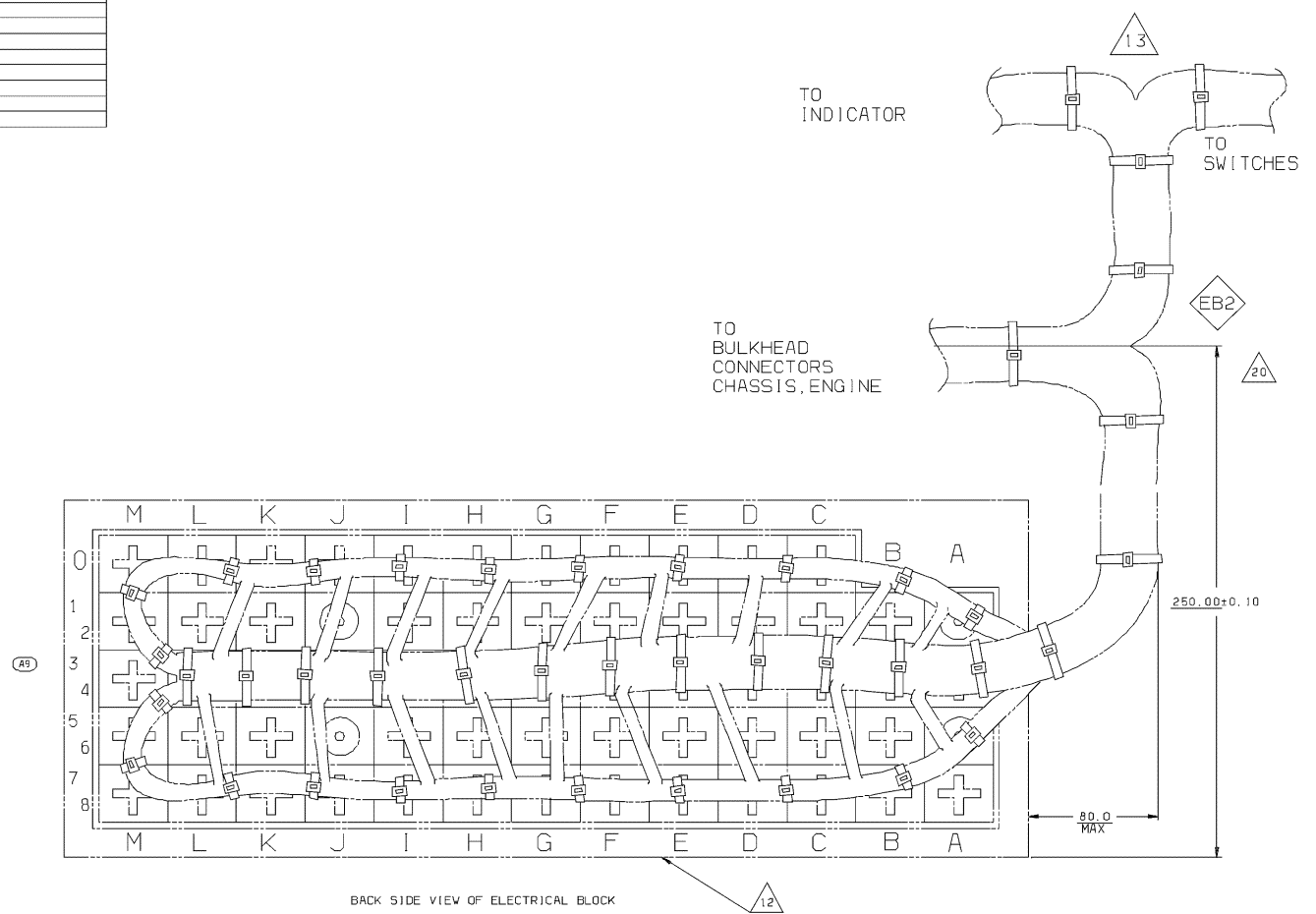



- 1 UNLESS OTHERWISE SPECIFIED, THIS ASSEMBLY MUST CONFORM TO FREIGHTLINER STANDARD 49-00106.
- 2 CONNECTOR END VIEWS ARE SHOWN FROM THE CABLE INSERTION END.
- 3 SINGLE ITEM USED IN MULTIPLE LOCATIONS.
- 4 CONNECT TOGETHER.
- 5 1587 CIRCUIT PAIRS (1587+A, ±C, ±E, ±S, ±T, ±W) ARE TO BE TWISTED TOGETHER AT A MINIMUM RATE OF ONE TWIST PER INCH.
- 6 SOLDER WIRE DIRECTLY TO INDICATED PIN ON ITEM #53 NATO LIGHT SWITCH CONNECTOR PER SHOP PRACTICE.
- 7 LOCATE SPLICE BELOW PDM.
- 8 AFTER CONNECTING ITEM 120 BUZZER ASSEMBLY, SECURE WITH ITEM 35 TIE WRAPS IN LOCATION INDICATED BETWEEN EB1 AND EB2. EDGE OF BUZZER MUST BE UNDER WIRE.

- 9 APPLY TAPE AROUND BASE OF CONNECTOR AT LEAST TWO WRAPS.
- 10 LOCATIONS PS1, PS2 AND PS3 ARE DIMENSIONED TO CONDUIT.
- 11 DRESS AND TIE STRAP ELECTRICAL BLOCK AS SHOWN IN THE VIEW.

RELEASE NUMBER	REV	DATE	DESCRIPTION	BY	CHK	APPD
P26618-18	0		1587 CIRCUIT PAIRS (1587+A, ±C, ±E, ±S, ±T, ±W) ARE TO BE TWISTED TOGETHER AT A MINIMUM RATE OF ONE TWIST PER INCH.			
P26618-18	1	03/22/06	1587 CIRCUIT PAIRS (1587+A, ±C, ±E, ±S, ±T, ±W) ARE TO BE TWISTED TOGETHER AT A MINIMUM RATE OF ONE TWIST PER INCH.			

RELEASE NUMBER	REV	DATE	DESCRIPTION	BY	CHK	APPD
P26618-19	0		1587 CIRCUIT PAIRS (1587+A, ±C, ±E, ±S, ±T, ±W) ARE TO BE TWISTED TOGETHER AT A MINIMUM RATE OF ONE TWIST PER INCH.			
P26618-19	1	01/11/08	1587 CIRCUIT PAIRS (1587+A, ±C, ±E, ±S, ±T, ±W) ARE TO BE TWISTED TOGETHER AT A MINIMUM RATE OF ONE TWIST PER INCH.			

RELEASE NUMBER	REV	DATE	DESCRIPTION	BY	CHK	APPD
P26618-20	0		1587 CIRCUIT PAIRS (1587+A, ±C, ±E, ±S, ±T, ±W) ARE TO BE TWISTED TOGETHER AT A MINIMUM RATE OF ONE TWIST PER INCH.			
P26618-20	1	11/20/05	1587 CIRCUIT PAIRS (1587+A, ±C, ±E, ±S, ±T, ±W) ARE TO BE TWISTED TOGETHER AT A MINIMUM RATE OF ONE TWIST PER INCH.			

ITEM NUMBER	QTY	ITEM NUMBER	DESCRIPTION	REF
B25	19, 1'	48-02493-163	CABLE-GXL, IMM2(16), 0	136
	2	PAC12034109	TERM-FEM, MP630L, 14-16GA	135
	3	PAC12124580	TERM-FEM, WP, 14-16AWG	134
	2	PAC12124582	TERM-MALE, WP, 14-16AWG	133
	7	23-12497-002	SEAL-CABLE, MP280S, MP280ST, WP, G	132
	2	PAC8917263	TERM-MALE, 56SER, 10-12AWG	131
A3	4	PAC2965439	TERM-MALE, 56SER, 18GXL-18-20SXL	130
B11	6	DP1059156	LOCK-TERM, 1CAV-2CIR, FUSE-CB, YL	129
	4, 3	DP1059099	LOCK-TERM, 1CAV-1CIR, FUSE-CB, YL	128
A4	2	PAC12124520	TERM-FEM, 56SER, NIB, 2X18GXL	127
	-	N/A	<NOT FOUND>	126
	-	N/A	<NOT FOUND>	125
	1	PAC12059716	PLUG-2CAV, MP630L, GRV	124
	1	PAC12015791	PLUG-1CAV, WP, BLK	123
	1	PAC12010973	RCPT-2CAV, WP, 1X2, BLK	122
	1	PAC12015793	PLUG-3CAV, WP, 1X3, BLK	121
	1	A06-20806-000	ASSY-BUZZER	120
	2	PAC12015792	PLUG-2CAV, WP, 1X2, BLK	119
	1	PAC12015345	RCPT-6CAV, MP280, 2X3, BLK, HNGDLK	118
	-	N/A	<NOT FOUND>	117
	1	PAC12015199	PLUG-2CAV, MP280, NAT, HNGD TPA	116
	7	PAC12048074	TERM-FEM, MP150S, 18AWG-16GX-TXL	115
B29	-	N/A	<NOT FOUND>	114
B29	-	N/A	<NOT FOUND>	113
A5	-	N/A	<NOT FOUND>	112
A5	-	N/A	<NOT FOUND>	111
A5	-	N/A	<NOT FOUND>	110
A5	-	N/A	<NOT FOUND>	109
	1	PAC12077411	TERM-FEM, MP280S, 16-18AWG	108
	1	PAC12034047	TERM-MALE, MP280, 16-18	107
B26	12	PAC12034047	TERM-MALE, MP280, 16-18	106
CA	5	A1 66098 7	TERM-MALE, MM3P SZ16, 16-18AWG	105
	15	DUF046020216141	TERM-MALE, S16, SOL, 16-18GA	104
	2	PAC12052139	TERM-FEM, MP480S, 10-12AWG	103
A6	5	PAC12020035	TERM-FEM, MP630, 2X18-20GXL	102
	2	PAC12064999	LOCK-TERM, MP280, PLUG-2X4, BL	101
	2	PAC12064996	PLUG-8CAV, MP280, 2X4, BLK	100
	1	A1 206036 3	RCPT-16CAV, CPC1(17-16), STD SEX	99
A7	-	N/A	<NOT FOUND>	98
A7	-	N/A	<NOT FOUND>	97
A7	-	N/A	<NOT FOUND>	96
	1	PAC6288539	RCPT-6CAV, 56SER, 1X6, BLK	95
	2	PAC02977373	PLUG-2CAV, 56SER, GRAY	94
	3	PAC12065141	LOCK-TERM, MP280, 8CAV, RCPT, GY	93
	3	PAC12066195	RCPT-8CAV, MP280, 2X4, BK	92
	2	PAC12089134	TERM-FEM, VG BASE, 14-16-2X18AWG	91
	1	PAC12004264	PLUG-2CAV, WB, BK, LAMP SKT	90
	4	23-11194-508	TERM-RING, 3/8" STUD, 8	89
	3	23-11194-510	TERM-RING, M101, 37U, 10-12	88
	1	23-11194-308	TERM-RING, 1/4" STUD, 8	87
	7	23-11194-310	TERM-RING, 1/4" STUD, 10/12	86
	3	23-11194-314	TERM-RING, M6, 31, 251, 14-16	85
	1	23-11194-210	TERM-RING, 1/4" STUD, 10/12	84
	2	23-11194-214	TERM-RING, M5(101), 14-16	83
	1	PAC12129157	LOCK-TERM, 2CAV-MP280-LT GRAY	82
	4	PAC12015952	PLUG-1CAV, MP480, HNGD LK, GRV	81
	1	PAC12015664	PLUG-4CAV, MP630, 1X4, BLK, HNGDLK	80
B28	8	PAC12015271	RCPT-2CAV, MP280, NAT HNGD TPA	79
	1	PAC12052613	PLUG-2CAV, MP480S, BLK	78
	1	PAC6288700	RCPT-6CAV, 56SER, 1X4&1X2H, BLK	77
	2	PAC2973890	PLUG-6CAV, 56SER, 1X4&1X2, BLK	76
	1	PAC2977042	RCPT-6CAV, 56SER, 2X6, NAT	75
	1	PAC2977044	PLUG-6CAV, 56SER, 2X3, BLK	74
	1	PAC2965019	PLUG-4CAV, 56SER, GRAY, NO LOCK	73
	4	PAC6294544	RCPT-4CAV, 56SER, 2X2, BK	72
	1	PAC2977048	PLUG-4CAV, 56SER, 2X2, BLK	71
	1	PAC2984678	RCPT-3CAV, 56SER, 1X2+1, BLK	70
	1	PAC2984378	PLUG-3CAV, 56SER, 1X2+1, BLK	69

ITEM NUMBER	QTY	ITEM NUMBER	DESCRIPTION	REF
A20	3	PAC06294466	RCPT-2CAV, 56SER, BLK	68
	2	PAC02984883	RCPT-2CAV, 56SER, BLK	67
	6	PAC02973781	PLUG-2CAV, 56SER, BLK	66
	6	PAC02984528	RCPT-1CAV, 56SER, BLK	65
B12	17	PAC02977253	PLUG-1CAV, 56SER, BLK	64
	5	681 545 17 20	PLUG-3CAV, 56SER, BLK, GAUGE	63
	19, 3	DP1059056	LOCK-TERM, MP630F, YELLOW	62
	10	06-42557-005	PLUG-6CAV, MP630, DP1CN 06F63U1	61
	1	06-17867-000	BOOT-PLASTIC, TURNSIG SV CONN	60
	1	GROO1 9952 70	PLUG-12CAV, TURN SIG, MP630-RLY	59
	1	681 545 02 89	LOCK-TERM, M1CP100, 2X16, "B" LK	58
	1	681 545 03 89	LOCK-TERM, M1CP100, 2X16, "A" LK	57
	1	PAC12045575	PLUG-32CAV, M1CP100, BK, 2X16	56
	1	419 990 70 54	NUT	55
	1	419 997 70 81	GROMMET	54
	1	419 542 70 55	HOUSING-PLUG	53
	3	JE190PC20R	INSULATOR/SEAL-BOOT TERMINAL	52
	9	PAC8917263	TERM-MALE, 56SER, 10-12AWG	51
	37	PAC12010106	TERM-MALE, 56SER, 14-16SXL	50
	2	PAC12015680	TERM-FEM, 56SER, NIB, 2X12-14GA	49
	2	PAC12124523	TERM-F, 56SER, NO NIB, 2X12-14GXL	48
	8	PAC12124518	TERM-FEM, 56SER, NIB, 12AWG	47
B13	30	PAC12124515	TERM-FEM, 56SER, NIB, 14-16AWG	46
B14	10	PAC12124512	TERM-FEM, 56SER, NIB, 16-20AWG	45
	17	PAC12146448	TERM-FEM, M1CP100, 16-18GXL	44
	31	PAC12020116	TERM-MALE, MP280, 14-16-2X18AWG	43
	1	PAC12015511	LOCK-TERM, MPMXD, 17CAV	42
	1	PAC12015510	LOCK-TERM, MPMXD, 22CAV	41
	1	PAC12015969	LOCK-TERM, MPMXD, 16CAV, M&F	40
	1	PAC12015968	LOCK-TERM, MPMXD, 18CAV, M&F	39
	1	PAC12020545	PLUG-34CAV, MXD, MP280-480-630	38
	1	PAC12015508	PLUG/RHD-42CAV, MP280-480-630	37
	20'	48-00126-007	MSC-3/4 BLK TAPE-MMM15	36
	25	23-09796-309	CLAMP-CABLE TIE, 1-3/4X8	35
	1'	48-02218-075	CONDUIT-POLYTH19MM, FLEX, GY, SLT	34
B15	30	23-11283-000	TERM-SPLC CLIP, S, 50-8 90MM2	33
	1	PAC12129155	RCPT-2CAV, MP280, BLK	32
	12	PACR62979	LABEL	31
	10	681 821 02 91	TUBE-HTS, DW 9, 52MMX30, 0L, R	30
B15	30	681 821 01 91	TUBE-HTS, DW 9, 52MMX25, 4L, BK	29
A21	18	681 821 00 91	TUBE-HTS, DW 6, 35MMX25, 4L, BK	28
	25, 9'	48-02493-104	CABLE-GXL, 5MM2(10), Y	27
	186, 5'	48-02493-124	CABLE-GXL, 3MM2(12), Y	26
	47, 4'	48-02493-144	CABLE-GXL, 2MM2(14), Y	25
B16	217, 2'	48-02493-164	CABLE-GXL, 1, 0MM2(16), Y	24
B17	208, 8'	48-02493-184	CABLE-GXL, 0, 8MM2(18), Y	23
	17, 6'	48-02223-089	CABLE-SXL, 8, 0MM2(18), W	22
	14, 4'	48-02223-109	CABLE-SXL, 5MM2(10), W	21
	19	PAC12084588	TERM-FEM, MP630-RLY, 10-12-2X14	20
A26	36	PAC12084590	TERM-FEM, MP630, 10-12-2X14-16GA	19
B18	111	PAC12015670	TERM-FEM, MP630, 14-16AWG	18
B19	49	PAC12015669	TERM-FEM, MP630, 18-20AWG	17
	1	PAC12084595	TERM-FEM, MP480, 10-12-2X16AWG	16
	4	PAC12052221	TERM-FEM, MP480, 12GXL-TXL	15
	16	PAC12124304	TERM-FEM, MP480, 14-16AWG	14
	24	PAC12129494	TERM-FEM, MP280, 12GXL-14AWG	13
B20	19	PAC12034046	TERM-FEM, MP280, 16T-GXL-18AWG	12
	2, 2	DP1023438	TERM-FEM-CB-FUSE, S-PLD, 10-12GA	11
	2, 4	DP1023439	TERM-FEM-CB-FUSE, S-PLD, 14-16GA	10
	2, 3'	48-02218-075	CONDUIT-POLYTH19MM, FLEX, GY, SLT	9
	2	DP1075588	SLV-INSLTR, BUSS BAR, 6-POS	8
	4	DP1075586	SLV-INSLTR, BUSS BAR, 5-POS	7
	3	DP1075575	SLV-INSLTR, BUSS BAR, 3-POS	6
	2	DP1092652	BB, 5-TERM, 0, 75CL, PLTD, L-CRIMP	5
	3	DP1092603	BB, 4-TERM, 0, 75CL, PLTD, L-CRIMP	4
	1	DP1092650	BB, 4-TERM, 0, 75CL, PLTD, R-CRIMP	3
	3	DP1092654	BB, 3-TERM, 0, 75CL, PLTD, R-CRIMP	2
A23	1	A06-39268-002	ELEC BLOCK-MAIN CENTER, CAB	1

ITEM NUMBER	QTY	ITEM NUMBER	DESCRIPTION	REF
7, 1'	48-02218-025	CONDUIT-POLYTHN, 6MM, FLEX, GY, SLT	166	
1	06-42557-000	PLUG-10CAV, MP630, PAC15393805 B	165	
4	PAC12124519	TERM-FEM, 56SER, NO NIB, 12AWG	164	
1, 3	PAC12124517	TERM-FEM, 56SER, NO NIB, 14-16AWG	163	
1'	48-00126-012	MSC-3/4 TAPE, .0077THK, RED, ELEC	162	
1'	48-00126-018	MSC-3/4 TAPE, .0077THK, YEL, ELEC	161	
2	A06-17895-002	DIODE, W/56 SRS CONNECTORS, 3AMP	160	
2	23-11194-608	TERM-RING, M12(1, 50), 8AWG	159	
1	PAC12103505	TERM-RING, .375IN-M10, 12-14AWG	158	
1	PAC12064753	LOCK-TERM, MP280, PLUG, 2X3	157	
1	PAC12064752	PLUG-6CAV, MP280, 2X3, BLK	156	
1	23-12497-000	SEAL-CABLE, MP280S, MP280ST, VP	155	
1	PAC05290433	TERM-SPLC CLIP, CA, 9, 4-21, 3 MM2	154	
3	PAC01864022	TERM-SPLC CLIP, CA, 6, 9-12, 45MM2	153	
1	DP1023440	TERM-FEM-CB-FUSE, S-PLD, 18GA	152	
-	N/A	<NOT FOUND>	151	
5	23-12497-006	SEAL-CABLE, MP150S, DKR, 2, 03-2, 8	150	
2	A1 280755 4	TERM-FEM, F375, 10-8AWG	149	
-	N/A	<NOT FOUND>	148	
2	PAC12089188	TERM-FEMALE, WP, 18AWG	147	
2	23-12497-025	SEAL-CABLE, MP480S, WBS, O	146	
-	N/A	<NOT FOUND>	145	
1	PAC12124522	TERM-FEM, 56SER, NIB, 2X14-16GA	144	
-	N/A	<NOT FOUND>	143	
31, 7'	48-25085-108	CABLE-TXL, IMM2(16), GY	142	
6	PAC12047581	TERM-MALE, MP150, 16-18 GXL	141	
2	23-12497-006	SEAL-CABLE, MP150S, DKR, 2, 03-2, 8	140	
2	PAC12047784	LOCK-TERM, MP150, RCPT-3CAV	139	
2	PAC12047782			



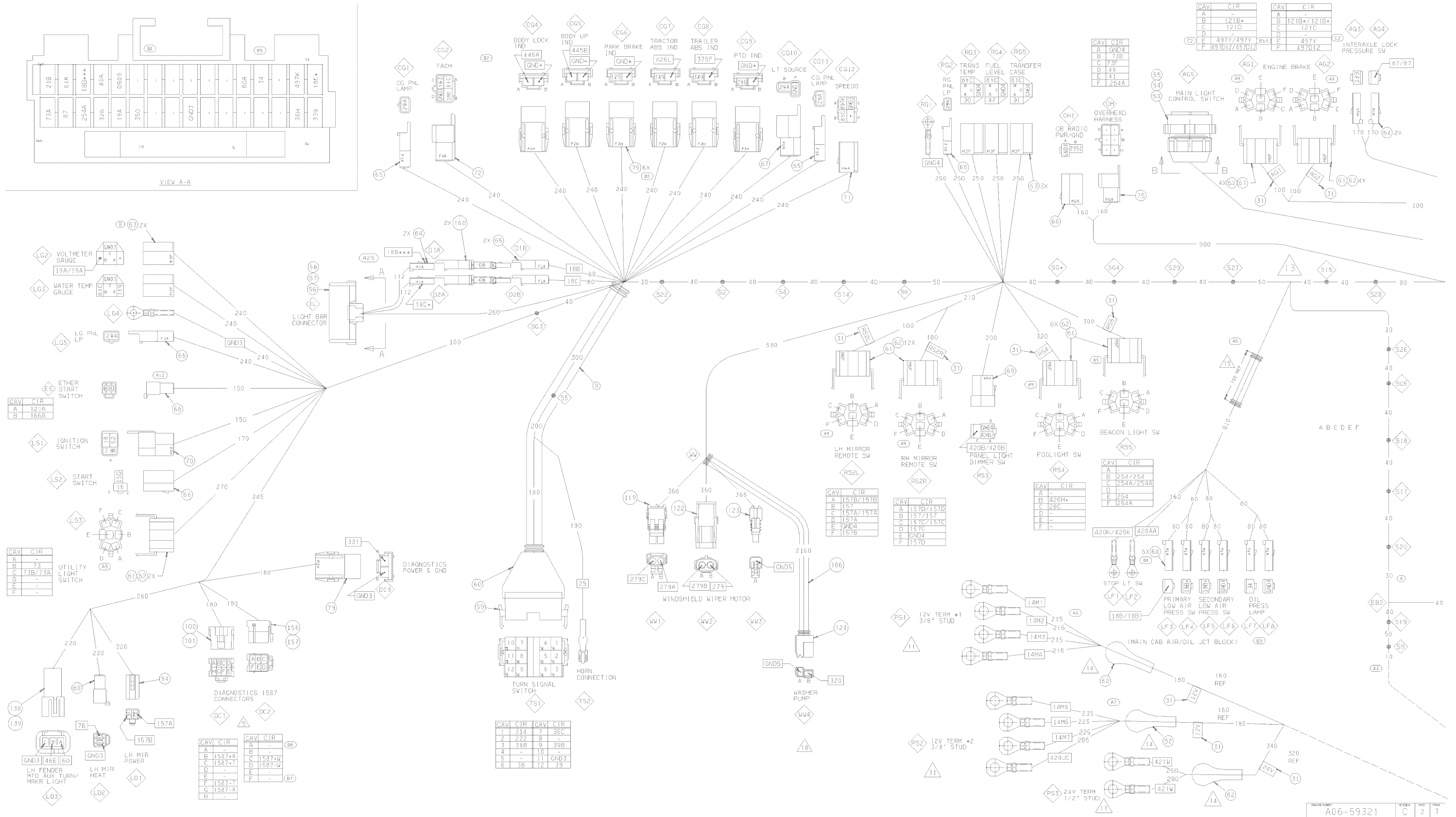













RELEASE NUMBER	REV	ZONE	REVISION DESCRIPTION	BY	DATE	APPD
P10107-23	-	XX	INITIAL RELEASE	REN	03/06/01	RJH
P10107-74	A	D5	24V STUD GRAPHICS REVISED & ITEM REF'S 19,20 WERE 6,14	M2S	04/26/01	RJH
	A1	D5	ITEM 21 WAS 4, QTY WAS "10X"			

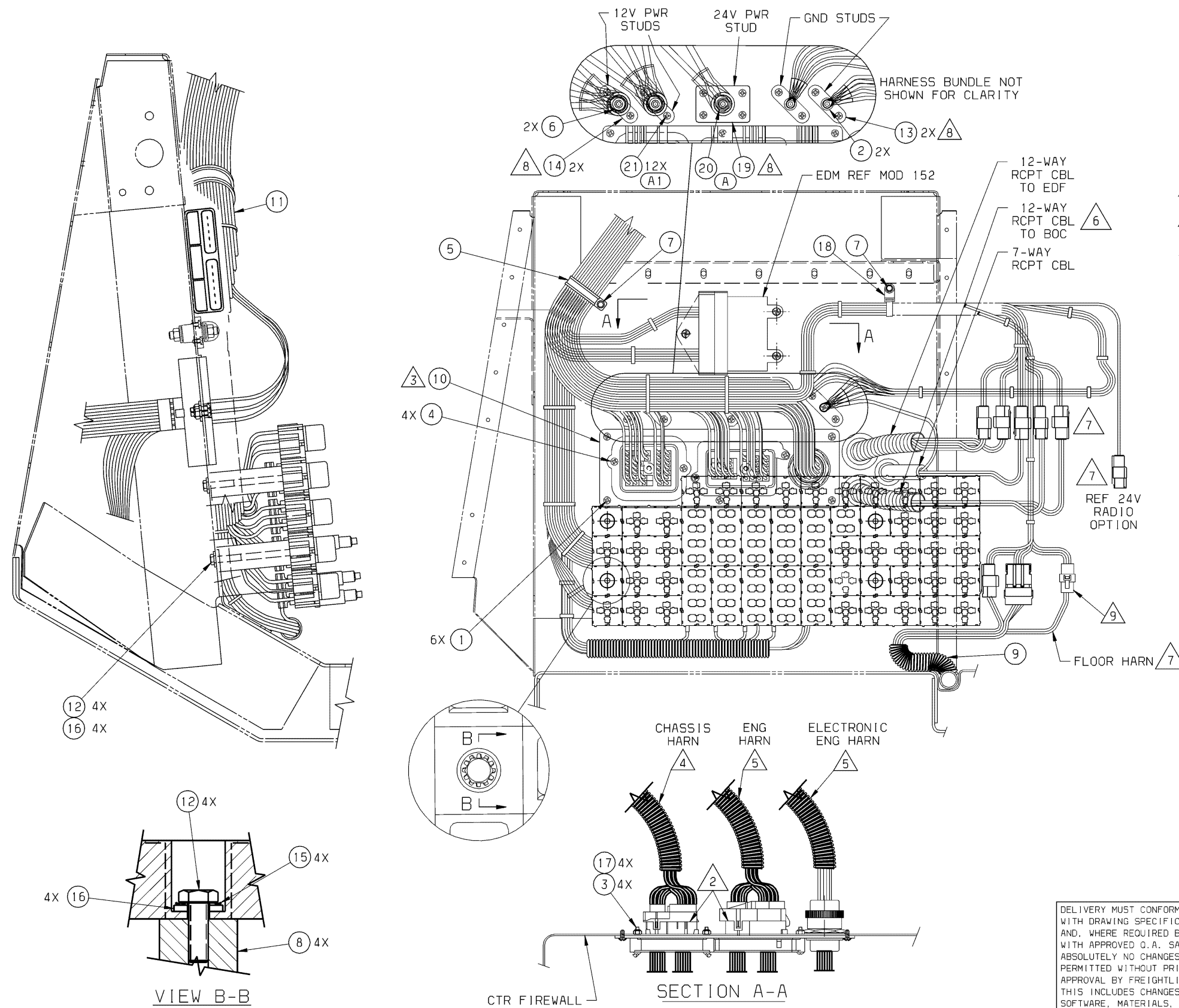

1. ROUTE AND CLAMP WIRING TO VOID CHAFING.
- 2 APPLY ELECTRICAL SEALANT GREASE 48-02439-000 INTO CONNECTORS FOR WEATHER RESISTANT SEAL.
- 3 APPLY 48-02454-206 SEALANT BETWEEN ITEM 21 PLATE AND FIREWALL.
- 4 SEE SPEC MODULE 288 FOR CHASSIS HARN.
- 5 SEE SPEC MODULE 286 FOR ENG HARN.
- 6 SEE SPEC MODULE 296/297 FOR 7-WAY AND 12-WAY TRLR RCPT.
- 7 ROUTING SHOWN OUT OF POSITION FOR CLARITY ONLY. INSTALL WIRING AND CONNECTORS INSIDE OF ELECTRICAL CENTER.
- 8 APPLY 48-00118-002 SEALANT BETWEEN TERMINAL BLOCK AND FIREWALL.
- 9 SEE SPEC MODULE 311 FOR DRL FLOOR HARNESS CALLOUT.

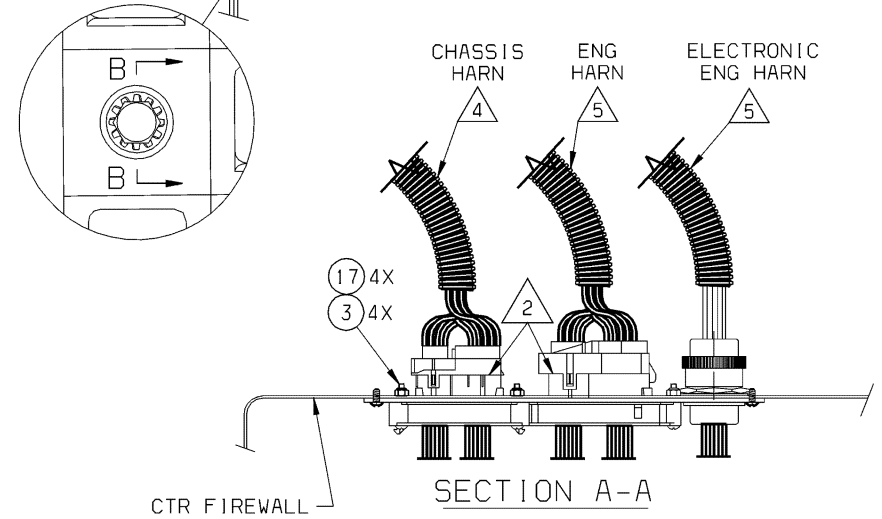
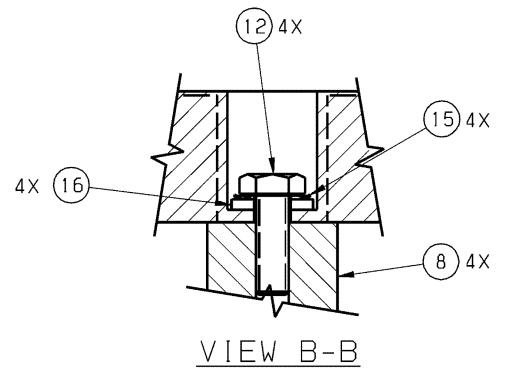

DELIVERY MUST CONFORM EXACTLY WITH DRAWING SPECIFICATIONS AND, WHERE REQUIRED BY O.A., WITH APPROVED O.A. SAMPLES. ABSOLUTELY NO CHANGES ARE PERMITTED WITHOUT PRIOR APPROVAL BY FREIGHTLINER LLC. THIS INCLUDES CHANGES TO: SOFTWARE, MATERIALS, INTERNAL COMPONENTS, MANUFACTURING PROCESSES.

FREIGHTLINER LLC			
THE INFORMATION CONTAINED HEREIN IS PROPRIETARY DATA, AND IS NOT FOR DISSEMINATION OR DISCLOSURE, IN WHOLE OR IN PART, FOR ANY PURPOSE OTHER THAN THAT FOR WHICH IT IS SUBMITTED, EXCEPT AS AUTHORIZED IN WRITING BY FREIGHTLINER LLC.			
MATERIAL APPROVAL	DATE	UNLESS OTHERWISE NOTED, DIMENSIONS AND TOLERANCES ARE DEFINED ACCORDING TO ANSI STANDARD Y14.5M-1982, WITH EXCEPTIONS PER FREIGHTLINER EOM SECT 307.	
XXX	XX/XX/XX		
DRAWN BY	DATE		
RICHARD NERIA	03/06/01		
CHECKED BY	DATE		
M2S-SIDDALL	03/06/01		
RESPONSIBLE ENGINEER	DATE	THIRD ANGLE PROJECTION	UNIT OF MEASURE
M2S-SIDDALL	03/06/01		NM
APPROVED BY	DATE	WFO ENG/PURCH AGENT	DATE
RICK HENRY	03/06/01	MIKE PUNCOCHAR	03/13/01
DESCRIPTION: INSTL-ELEC CENTER, MAIN CAB			
SUPPLEMENTARY DESCRIPTION: 320A1 M915A3-22 M916A3 M917A2			
ITEM/DRAWING NUMBER	REVISION LETTER	SHEET NUMBER	
D06-40331	A	1 OF 1	



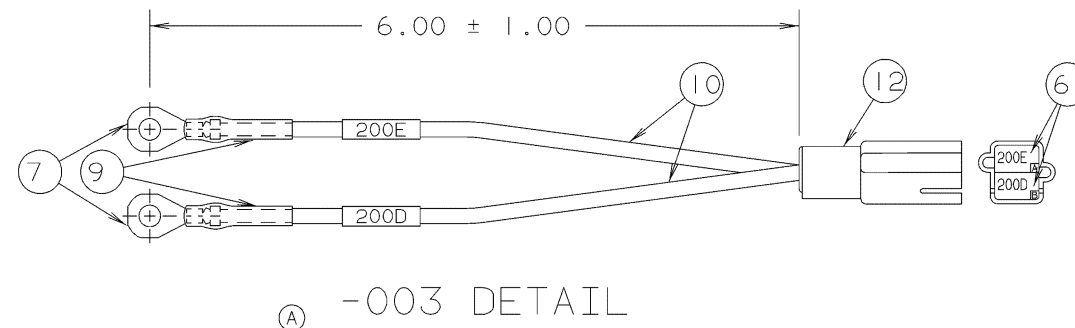
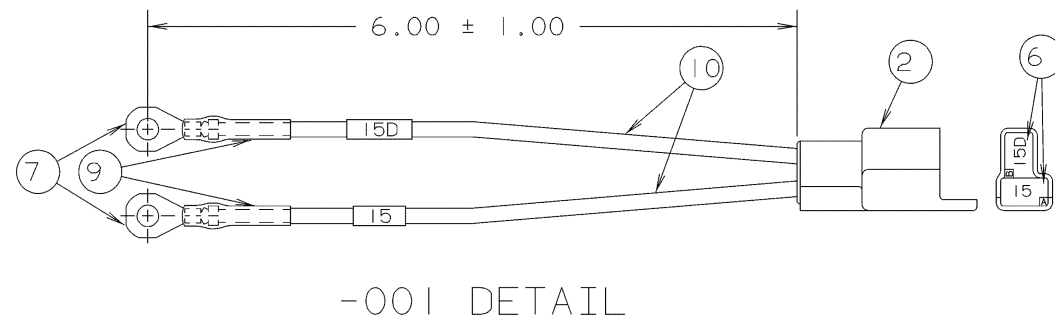
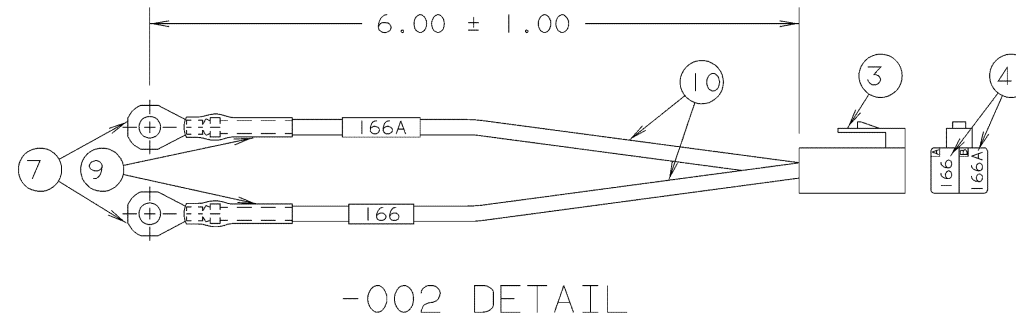
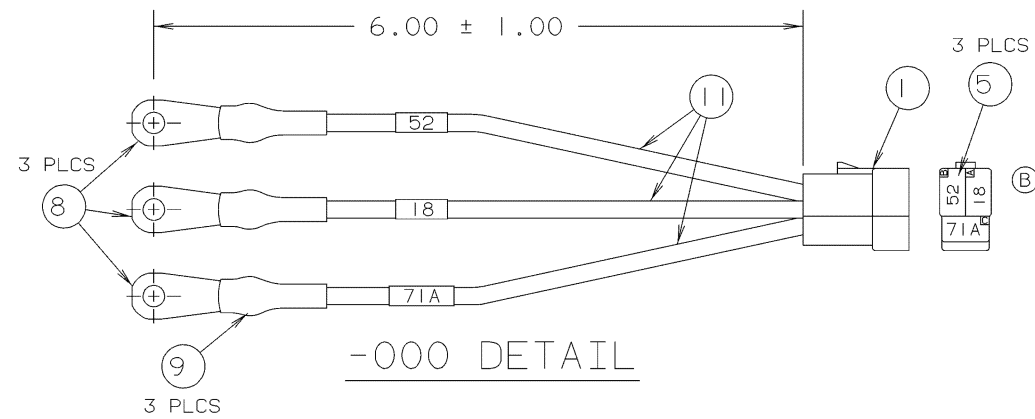

- 1 INSTALL TERMINALS PER F/L PROCESS SPEC #49-00052.
- 2 STAMP CIRCUIT NUMBER EVERY 1 TO 3 INCHES ALONG WIRE.
- 3 APPLY A 1 INCH PIECE OF ITEM 9 HEAT SHRINK OVER EACH RING TERMINAL AS SHOWN.
- 4 PART NUMBER TO BE APPLIED PER F/L PROCESS SPEC #49-00051.
- 5 CONECTOR END VIEWS ARE SHOWN FROM THE CABLE INSERTION END.

				MFR. DASH NO.	PART NUMBER	NAME OF PART	MATERIAL	ITEM
1'				PAC	8911922	CONN,HSG,2-BLD	F2C	12
			1.5'		-----	WIRE,#12 AWG SXL,WHT	48-02223-129	11
	1'	1'			-----	WIRE,#14 AWG SXL,WHT	48-02223-149	10
.16'	.16'	.16'	.25'		-----	TUBE,HEAT SHRINK	48-02461-025	9
	1		3		23-11194-210	TERM,RING	#10-12 AWG TO #10 STUD	8
	2	2			23-11194-214	TERM,RING	#14-16 AWG TO #10 STUD	7
		2			23-11193-114	TERM,BLD,MALE,56SRS	#14 AWG	6
			3		23-11192-112	TERM,BLD,FEM,56 SRS	#12 AWG	5
	2				23-11192-114	TERM,BLD,FEM,56 SRS	#14-16 AWG	4
	1			PAC	2977373	CONN,PLUG,2-BLD	M2B	3
		1		PAC	2984883	CONN,HSG,2-BLD	F2A	2
			1	PAC	2984378	CONN,PLUG,3-BLD	M3A	1
-003	-002	-001	-000	MFR. DASH NO.	PART NUMBER	NAME OF PART	MATERIAL	ITEM

LTR.	JOB NO.	DATE	BY	APPR.	FROM	CHANGE INFORMATION	TO
B	P07639-R5	11-23-99	JEW	JEW TLH		-000 SWAPPED CKTS 18&52. ADDED NOTE 5	
A	PB1000	05-23-89	DHW	TCA KVM		ADDED -003 ASSY	
-	PB1000	04-05-89	DHW	TCA KVM		INITIAL RELEASE	

PTO SWITCH ETHER SW HARN START SW HARN IGN SW HARN				FREIGHTLINER LLC PORTLAND, OREGON		THE INFORMATION CONTAINED HEREIN IS THE PROPRIETARY DATA OF FREIGHTLINER LLC AND IS NOT FOR DISSEMINATION OR DISCLOSURE IN WHOLE OR IN PART. FOR ANY PURPOSE OTHER THAN THAT FOR WHICH IT IS SUBMITTED EXCEPT AS AUTHORIZED IN WRITING BY FREIGHTLINER LLC.		
				THIRD ANGLE PROJECTION	UNLESS OTHERWISE NOTED UNITS = INCHES	DIMENSIONS AND TOLERANCES IN ACCORDANCE WITH ANSI Y14.5 - 1973 WITH EXCEPTIONS PER FREIGHTLINER E.O.M. SECTION 307		
DRAWN BY	DHW	04-05-89	286 HARN		JUMPER	SW PANEL		
DTG. CHECKED	TCA	04-05-89	PRIMARY ITEM		PRIMARY DESCP.	2ND DESCP.		
DESIGN APPROVAL	DHW	04-05-89	LOCATION		MFR.			
MFG. APPROVAL			IGN,START,ETHER & PTO SWS		ADDITIONAL INFORMATION			
FINAL APPROVAL	KVM	04-05-89	SCALE	SHEET	DRAWING NUMBER	CHG. LTR.		
			NONE	1 OF 1	A06-18247	B		





RELEASE NUMBER	REV	ZONE	REVISION DESCRIPTION	BY	DATE	APPD
PL0362-02	D		REVISED AND REDRAWN.	R.L.	04/01/93	NCP
	D1	A2	ADDED -001 AND -002.			
	D2	A5	ADDED NOTES 4 & 5	R.L.	04/08/94	NCP
PL0362-27	E	A5	REV'D NOTE 4 & ADDED NOTE 6.	R.L.	04/08/94	NCP
	E1	B3	ITEM 15 WAS PAC15052388			
	E2	B3	ITEM 14 WAS PAC12092059			
	E3	B3	ITEM 13 WAS PAC12092030			
	E4	B3	ITEM 12 WAS PAC12020720			
	E5	B3	ITEM 11 WAS PAC12064953			
	E6	B3	ITEM 10 WAS PAC12092377			
	E7	B5	WIRE WAS ITEM 16.			
	E8	A8	ADDED DETAIL A.			
	E9	A3	UPDATED PLUG.			
PA2120-W9	F	C2	ADDED ITEM #19	TLD	11/08/95	JMR

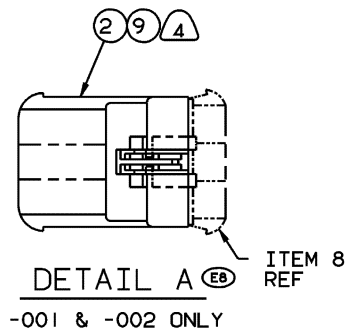
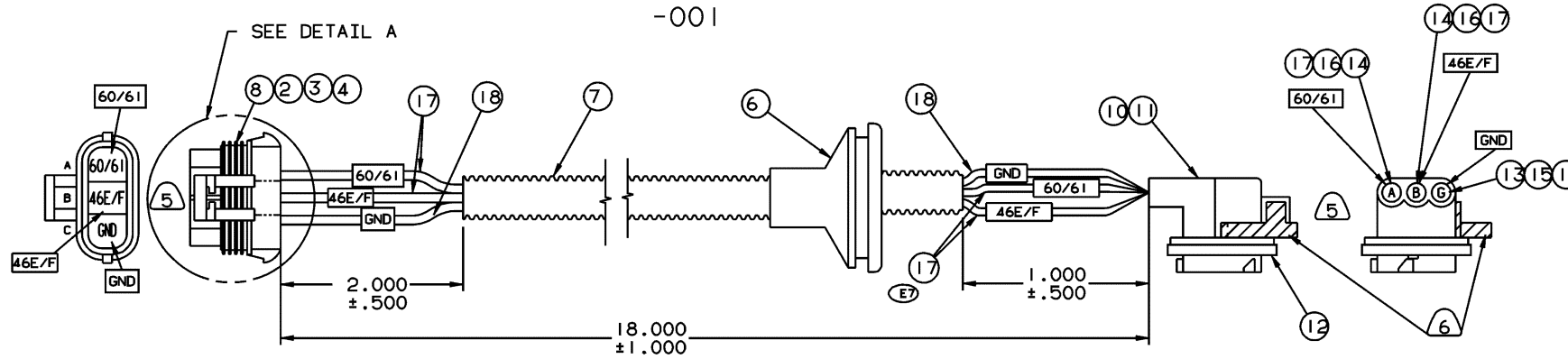
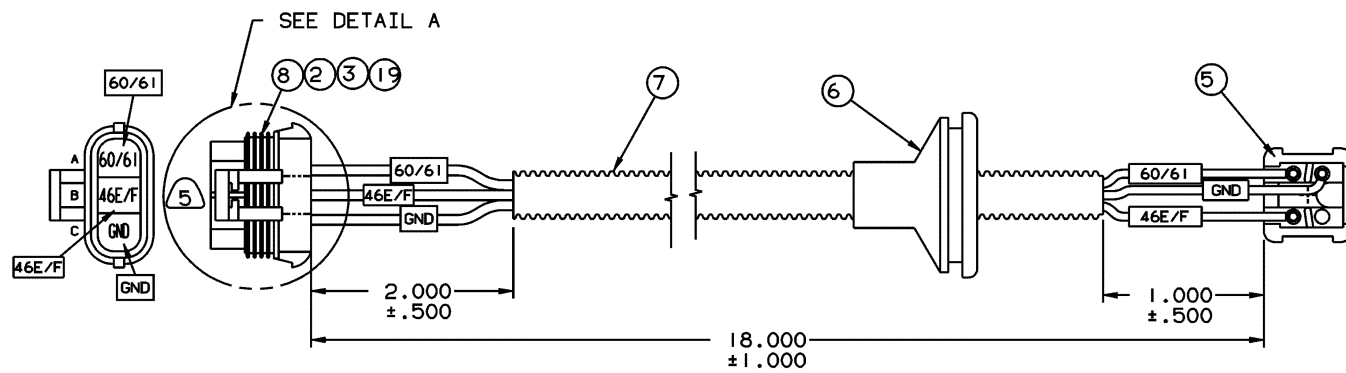
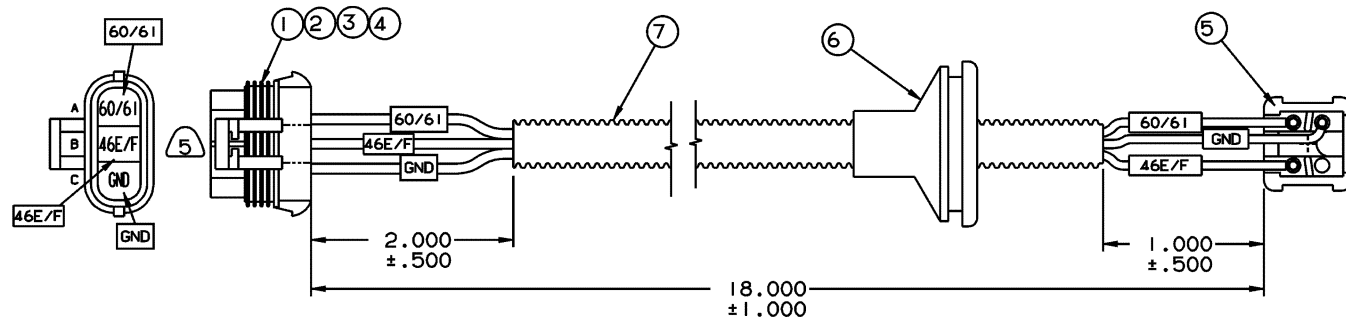

1. POSITION WIRES AS SHOWN.  
POSITION "A" FOR TURN SIGNAL  
POSITION "B" FOR SIDE MARKER  
POSITION "C" FOR GROUND
- 2 UNLESS OTHERWISE SPECIFIED, THIS ASSEMBLY MUST CONFORM TO FREIGHTLINER STANDARD 49-00052.
3. STAMP CIRCUIT NUMBER EVERY 3" TO 6" OVER ENTIRE LENGTH OF WIRE.
- 4 THESE ARE EXTRA PARTS FOR SERVICE REPLACEMENT OF HARNESS WHEN MATING HARNESS HAS OLD STYLE SERIES 630 CONNECTOR. REMOVE OLD STYLE 630 CONNECTOR, ITEMS 2 OR 9. SEE DETAIL A.
- 5 ALL CONNECTORS SHOWN FROM WIRE INSERTION END.
- 6 ITEM 10, PAC12066592, LOCKING ARM IS TO BE REMOVED BY HEADLAMP VENDOR PRIOR TO INSTALLING HARNESS ASSEMBLY ONTO LAMP BEZEL ASSEMBLY, REF P/N A06-20853.

	3		PAC12059258	SEAL 14GA SX <sub>1</sub> SXL	19
	2'		48-02223-189	WIRE, 18 AWG, SXL	18
	3'		48-02223-149	WIRE, 14 AWG, SXL	17
	2		PAC12015360	SEAL, 14 GA SXL	16
E1	1		PAC12015284	SEAL, 18 GA SXL	15
E2	2		PAC12066639	TERM	14
E3	1		PAC12066638	TERM	13
E4	1		PAC12129909	GASKET	12
E5	1		PAC12066542	INSERT, WDG BASE	11
E6	1		PAC12066592	SOCKET	10
	1	1	PAC12124686	HOUSING, 3-PIN 4	9
E9	1	1	PAC12124685	PLUG, 3-PIN	8
	15"	15"	48-02217-038	CONDUIT-TUBING	7
	1	1	GRO01 9233 71	GROMMET	6
	1	1	A06-17231-000	CONNECTOR ASSY	5
	3	3	PAC12052387	SEAL 14GA SXL	4
	3	3	PAC12052455	TERM FEM, 630 SEALED M/P	3
	2	2	PAC12045699	LOCK, SECONDARY 4	2
E9			PAC12065793	PLUG, 3-PIN	1
QUANTITY	QUANTITY	QUANTITY	ITEM NUMBER	DESCRIPTION	REF
<b>FREIGHTLINER LLC</b>					
THE INFORMATION CONTAINED HEREIN IS PROPRIETARY DATA, AND IS NOT FOR DISSEMINATION OR DISCLOSURE, IN WHOLE OR IN PART, FOR ANY PURPOSE OTHER THAN THAT FOR WHICH IT IS SUBMITTED, EXCEPT AS AUTHORIZED IN WRITING BY FREIGHTLINER LLC.					
MATERIAL APPROVAL		DATE		UNLESS OTHERWISE NOTED, DIMENSIONS AND TOLERANCES ARE DEFINED ACCORDING TO ANSI STANDARD Y14.3M-1992, WITH EXCEPTIONS PER FREIGHTLINER EOM SECT 307.	
DRAWN BY R.LARRY		DATE 03/18/93		THIRD ANGLE PROJECTION	
CHECKED BY ARC		DATE 05/12/93		UNIT OF MEASURE INCH	
RESPONSIBLE ENGINEER R.LARRY		DATE 03/23/93		RESPONSIBLE MFG. ENGR. B.MOSHOFSKY	
APPROVED BY M.PRANGER		DATE 04/01/93		DATE 04/23/93	
DESCRIPTION HARN/SCKT-T S/MRKR,FLD					
SUPPLEMENTARY DESCRIPTION FLD-AERO					
ITEM/ORDRNG NUMBER A06-17188				REVISION LETTER SHEET NUMBER F 1 OF 1	



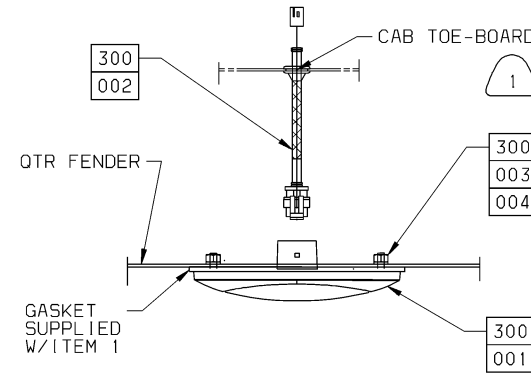
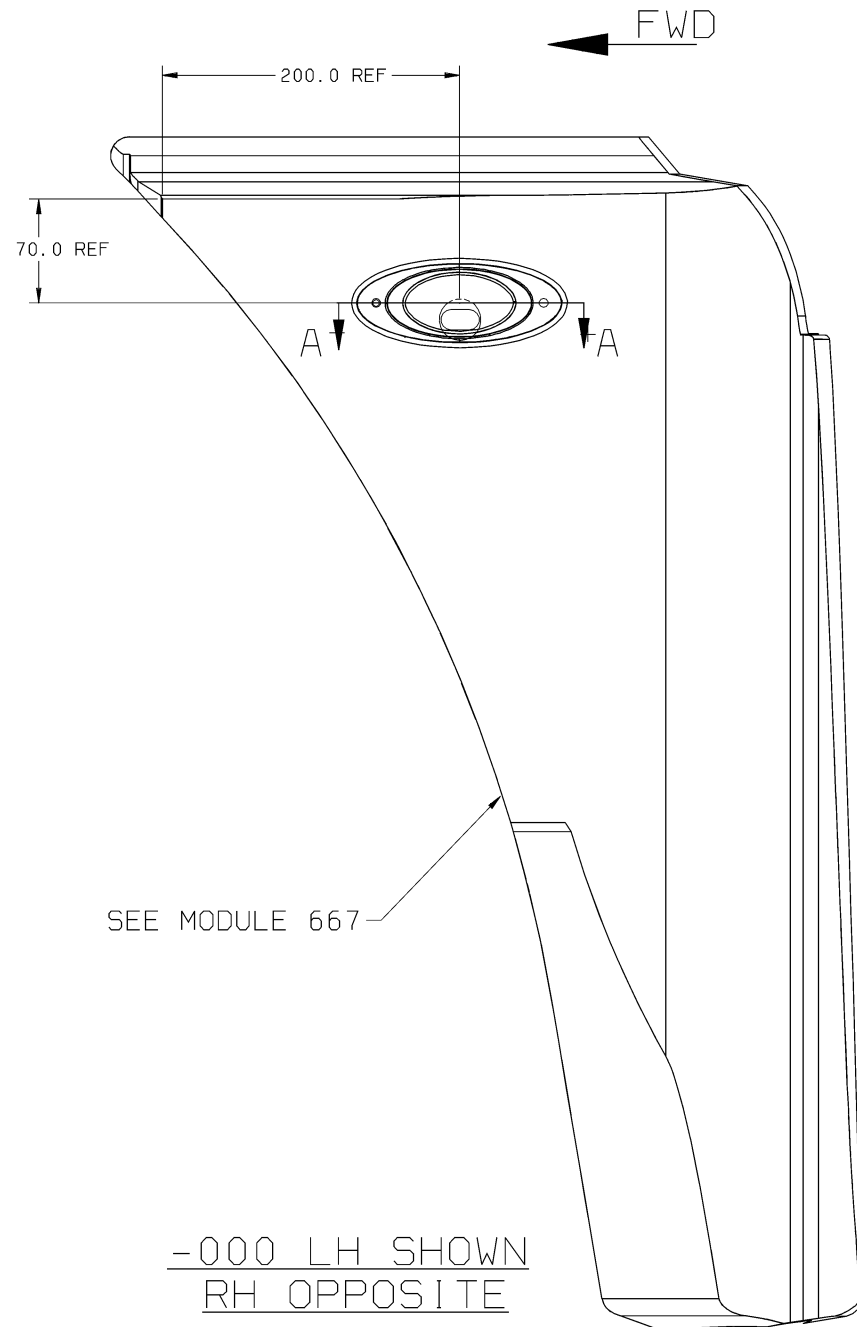

VIEW A-A

RELEASE NUMBER	REV LTR	ZONE	REVISION DESCRIPTION	BY	DATE	APPR
P13621-06	-	-	INITIAL RELEASE	DWD	01/29/01	JLT
P13621-44	A	-	REMOVED HOLE PATTERN "A"	DWD	05/11/01	JLT

DELIVERY MUST CONFORM EXACTLY WITH DRAWING SPECIFICATIONS AND, WHERE REQUIRED BY O.A., WITH APPROVED O.A. SAMPLES. ABSOLUTELY NO CHANGES ARE PERMITTED WITHOUT PRIOR APPROVAL BY FREIGHTLINER LLC. THIS INCLUDES CHANGES TO: SOFTWARE, MATERIALS, INTERNAL COMPONENTS, MANUFACTURING PROCESSES.

CONTRACT NUMBER  
DAAE07-00-D-S022  
PO#  
64678

ITEM NUMBER D06-39670-000	<b>FREIGHTLINER<sup>®</sup> LLC</b>		
	THE INFORMATION CONTAINED HEREIN IS PROPRIETARY DATA, AND IS NOT FOR DISSEMINATION OR DISCLOSURE, IN WHOLE OR IN PART, FOR ANY PURPOSE OTHER THAN THAT FOR WHICH IT IS SUBMITTED, EXCEPT AS AUTHORIZED IN WRITING BY FREIGHTLINER LLC.		
	MATERIAL APPROVAL	DATE	
	D. DEAVILLE	01/29/01	
	CHECKED BY	DATE	
P. MORENO	02/15/01		
RESPONSIBLE ENGINEER	DATE	THIRD ANGLE PROJECTION	UNITS OF MEASURE MM
D. DEAVILLE	01/29/01		
APPROVED BY	DATE	WFO ENGR/PURCH AGENT	DATE
J. TUSSE	02/02/01	KEN SHAW	02/06/01
DESCRIPTION	INSTL-LED TURN/MARKER LT, FNDR		
SUPPLEMENTARY DESCRIPTION	300A1 MILITARY, TL 07302Y		
ITEM/DRAWING NUMBER	D06-39670	REVISION LETTER	A
			SHEET NUMBER 1 OF 1

1 INSTALL ITEMS 1, 3 & 4 AND TORQUE TO 24 TO 36 IN LB.



F/L CIR NO	SAE CIR NO	WIRE ITEM NO	FROM			TO			APPROX LENGTH -000	CIRCUIT DESCRIPTION		
			LOC	TERM ITEM NO	SEAL INSL NO	CONN CAV POS	LOC	TERM ITEM NO			SEAL INSL NO	CONN CAV POS
60/61	1313	2	TS	6	8	A	CH	4	-	A	305	TURN SIGNAL LP SPLY, RH/LH
GND	1204	2	TS	6	8	B	CH	4	-	B	305	GND, GENERAL CAB/CHASSIS

RELEASE NUMBER	REV LTR	ZONE	REVISION DESCRIPTION	BY	DATE	APPD
P17957-01	-	-	INITIAL RELEASE	JEW	02/10/02	CAC

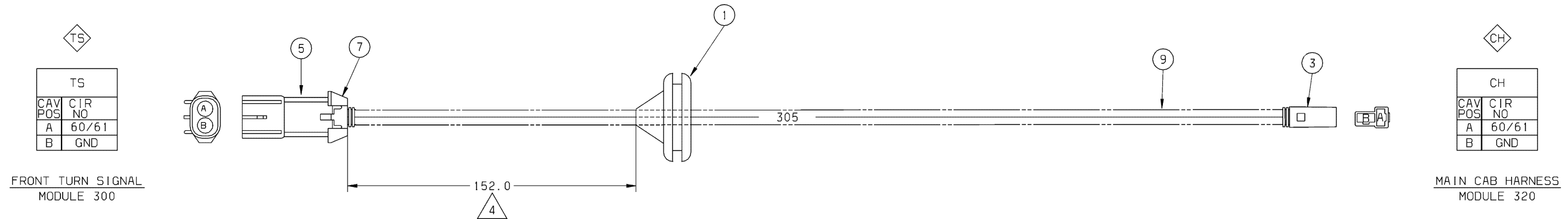

TS

CAV POS	CIR NO
A	60/61
B	GND

FRONT TURN SIGNAL  
MODULE 300

CH

CAV POS	CIR NO
A	60/61
B	GND

MAIN CAB HARNESS  
MODULE 320

- UNLESS OTHERWISE SPECIFIED, THIS ASSEMBLY MUST CONFORM TO FREIGHTLINER STANDARD 49-00106.
- CONNECTOR END VIEWS ARE SHOWN FROM THE CABLE INSERTION END.
- DIMENSION VALUES SHOWN REPRESENT THE LENGTH TO THE BACK (BUNDLE) END OF THE CONNECTOR OR TO THE POINT INDICATED BY THE ARROW. THIS CONVENTION DIFFERS FROM THE METHOD STATED IN 49-00106.
- DIMENSION IS FOR REFERENCE ONLY.

.9'	48-02217-025	CONDUIT-NYL, 6MM, FLEX, BLK, SLIT	9
2	23-12497-001	SEAL-CABLE, MP280-WP, BLU, 14S-12	8
1	PAC15300014	LOCK-TERM, 2CAV, MP280S, F&M, BLUE	7
2	PAC12129497	TERM-MALE, MP280S, 12-14AWG	6
1	PAC15300002	RCPT-2CAV, MP280S, BLK	5
2	23-11192-114	TERM-FEM, 56SER, NIB, 14-16AWG	4
1	PAC02973781	PLUG-2CAV, 56SER, BLK	3
2'	48-02493-144	CABLE-GXL, 14GA, YELLOW, LOW TNSN	2
1	681 997 05 81	GROMMET-RUBBER, CONICAL, SPECIAL	1
QTY	ITEM NUMBER	DESCRIPTION	REF

ITEM NUMBER A06-43550-000	DESCRIPTION HARN-LIGHT, SIGNAL, FENDER	<b>FREIGHTLINER LLC</b>			
		THE INFORMATION CONTAINED HEREIN IS PROPRIETARY DATA, AND IS NOT FOR DISSEMINATION OR DISCLOSURE, IN WHOLE OR IN PART, FOR ANY PURPOSE OTHER THAN THAT FOR WHICH IT IS SUBMITTED, EXCEPT AS AUTHORIZED IN WRITING BY FREIGHTLINER LLC.			
		MATERIAL APPROVAL XXX	DATE XX/XX/XX	UNLESS OTHERWISE NOTED, DIMENSIONS AND TOLERANCES ARE DEFINED ACCORDING TO ANSI STANDARD Y14.5M-1982, WITH EXCEPTIONS PER FREIGHTLINER EGM SECT 307.	
		DRAWN BY J. WHITING	DATE 02/08/02	CHECKED BY D. WHITELEY	DATE 02/08/02
RESPONSIBLE ENGINEER P. BRANDT		DATE 02/08/02	THIRD ANGLE PROJECTION	UNITS OF MEASURE MM	
APPROVED BY C. COVERDILL		DATE 02/08/02	MFG ENGR/PURCH AGENT J. GOMEZ	DATE 02/16/02	
DESCRIPTION HARN-LIGHT, SIGNAL, FENDER					
SUPPLEMENTARY DESCRIPTION 30003 JUMPER HARN THRU DECK					
ITEM/DRAWING NUMBER A06-43550			REVISION LETTER -	SHEET NUMBER 1 OF 1	



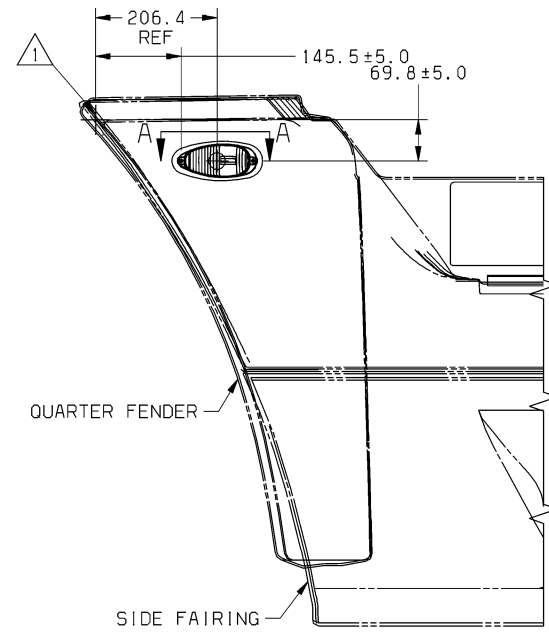

FLD120 SET BACK AXLE  
LH SHOWN, RH OPPOSITE

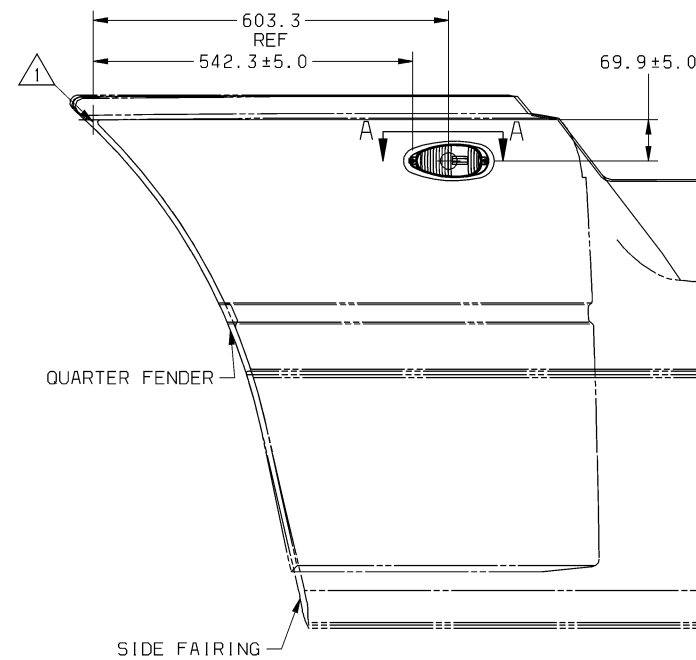

FLD120 SET FORWARD AXLE  
LH SHOWN, RH OPPOSITE

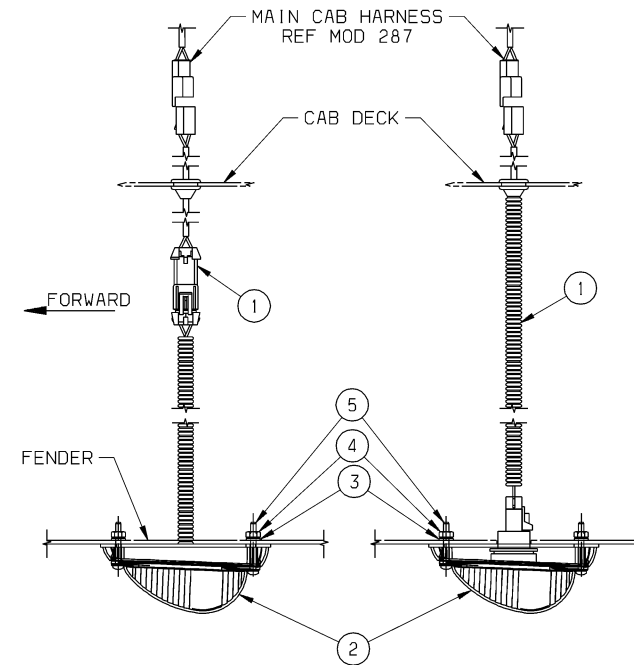

VIEW A-A  
-000

VIEW A-A  
-001

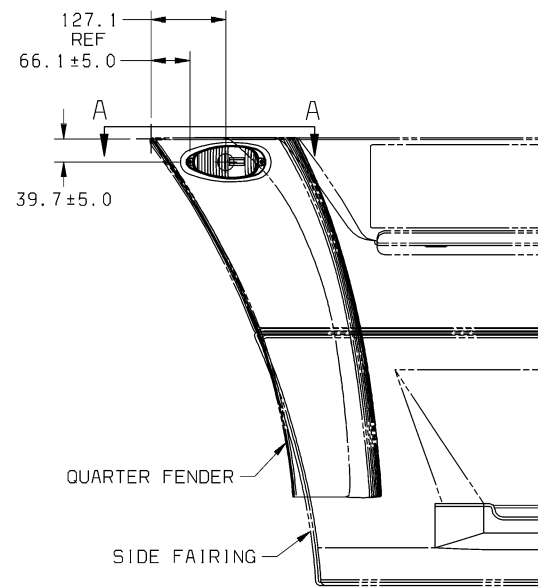

FLD112 SET BACK AXLE  
LH SHOWN, RH OPPOSITE

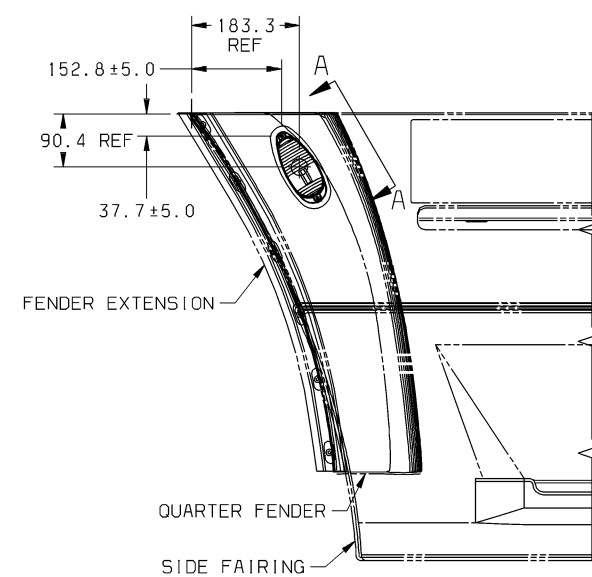

FLD112 SET BACK AXLE  
W/FENDER EXTENSION  
LH SHOWN, RH OPPOSITE

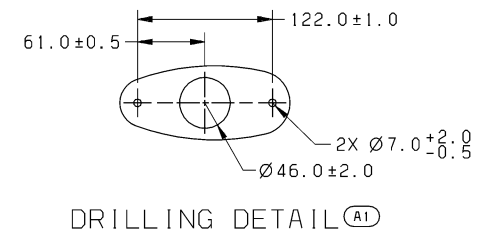

① DIMENSION TAKEN FROM FORWARD EDGE OF FLAT FLANGE OF STATIONARY FENDER.

② 2. TORQUE FASTENERS TO 6-8 Nm (4.4-5.9 FT-LBS)

DELIVERY MUST CONFORM EXACTLY WITH DRAWING SPECIFICATIONS AND, WHERE REQUIRED BY O.A., WITH APPROVED O.A. SAMPLES. ABSOLUTELY NO CHANGES ARE PERMITTED WITHOUT PRIOR APPROVAL BY FREIGHTLINER LLC. THIS INCLUDES CHANGES TO: SOFTWARE, MATERIALS, INTERNAL COMPONENTS, MANUFACTURING PROCESSES.

RELEASE NUMBER	REV	ZONE	REVISION DESCRIPTION	BY	DATE	APPD
P00511-06	-	-	INITIAL RELEASE	AJD	09/22/97	ANF
P18972-04	A	A2	ADDED -001	ACH	04/22/03	CPJ
	A1	B2	UPDATED DRILLING			
	A2	A4	ADDED TORQUE SPEC.			

ITEM NUMBER		DESCRIPTION		DATE		DATE		DATE	
D06-27767-001		INSTL-TRN SIG, AUX, FLD, FNDR		09/22/97		04/23/03		04/22/03	
D06-27767-000		INSTL-TRN SIG, AUX, FLD, FNDR		04/23/03		04/23/03		04/22/03	
D06-27767-001		INSTL-TRN SIG, AUX, FLD, FNDR		04/23/03		04/23/03		04/22/03	
<b>FREIGHTLINER® LLC</b>									
THE INFORMATION CONTAINED HEREIN IS PROPRIETARY DATA, AND IS NOT FOR DISSEMINATION OR DISCLOSURE, IN WHOLE OR IN PART, FOR ANY PURPOSE OTHER THAN THAT FOR WHICH IT IS SUBMITTED, EXCEPT AS AUTHORIZED IN WRITING BY FREIGHTLINER LLC.									
DRAWN BY D. PORTER				DATE 09/22/97		UNLESS OTHERWISE NOTED, DIMENSIONS AND TOLERANCES ARE DEFINED ACCORDING TO ASME STANDARD Y14.5M-1994, WITH EXCEPTIONS PER FREIGHTLINER EOSH 09EO-K17.			
CHECKED BY J. ELMORE				DATE 04/23/03		THIRD ANGLE PROJECTION		UNITS OF MEASURE MM	
RESPONSIBLE ENGINEER D. PORTER				DATE 04/23/03		MFG ENGR/PURCH AGENT L. DETRICK		DATE 04/22/03	
APPROVED BY A. FRESHWATER				DATE 04/23/03		DESCRIPTION INSTL-TRN SIG, AUX, FLD, FNDR			
						SUPPLEMENTARY DESCRIPTION 300A1 FLD/D2			
						ITEM/DRAWING NUMBER D06-27767			
						REVISION LETTER A			
						SHEET NUMBER 1 OF 1			





RELEASE NUMBER	REV	ZONE	REVISION DESCRIPTION	BY	DATE	APPD.
P10107-19	-	XX	INITIAL RELEASE	MDD	01/31/01	RJH
P10107-76	A	B3	ADDED ITEM 11	MDD	04/28/01	RJH
	A1	B3	REPLACED AMP COMPONENTS WITH PAC PART NUMBER.			

F/L CIR NO	SAE CIR NO	WIRE ITEM NO	FROM				TO				APPROX LENGTH -000	CIRCUIT DESCRIPTION
			LOC	TERM ITEM NO	SEAL INSL NO	CONN CAV POS	LOC	TERM ITEM NO	SEAL INSL NO	CONN CAV POS		
60/61	1313	1	2	5		A	1	7	8	C	1305	TURN SIG LP SPLY, RH/LH FR
46	1303	1	2	5		B	1	7	8	B	1305	MARKER LP SPLY, TRACTOR
GND	1204	1	2	5		C	1	7	8	A	1305	GND, GENERAL CAB/CHASSIS

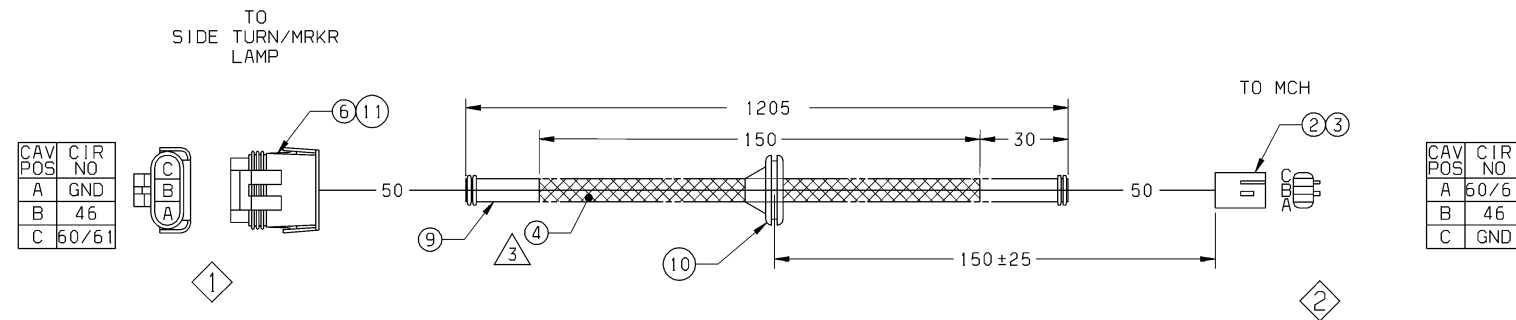

- 1 UNLESS OTHERWISE SPECIFIED, THIS ASSEMBLY MUST CONFORM TO FREIGHTLINER STANDARD 49-00106.
- 2 CONNECTOR END VIEWS ARE SHOWN FROM THE CABLE INSERTION END.
- 3 TAPE CONDUIT WITH 50% TAPE OVERLAP TO PROVIDE DOUBLE THICKNESS.

ITEM NUMBER A06-39668-000	DESCRIPTION HARN-JMPR, SIDE TURN/MRKR LAMP	1	PAC12052845	LOCK-TERM, 3CAV, MP150S-M & F	11		
		1	681 997 05 81	GROMMET-RUBBER, CONICAL, SPECIAL	10		
		3.9'	48-02218-025	CONDUIT-POLTHN, 6MM, FLEX, GRAY	9		
		A1	3	PAC12052924	SEAL-CABLE, MP150, DK RED, REEL	8	
		A1	3	PAC12048074	TERM-FEM, MP150S, 16/18	7	
		A1	1	PAC12059595	PLUG-3CAV, MP150S, BLK	6	
		3	PAC12047767	TERM-FEM, MP150, 16GXL-18AWG	5		
		2.0'	48-00126-007	MSC-3/4 BLK TAPE-MMM15	4		
		1	PAC12047783	LOCK-TERM, 3CAV, MP150-PLUG	3		
		1	PAC12047781	PLUG-3CAV, MP150, BLK.	2		
		12.8'	48-25085-108	CABLE-TXL, 16/1. GA, GRY, LOW TNSN	1		
		QTY	ITEM NUMBER	DESCRIPTION	REF		
				<b>FREIGHTLINER® LLC</b>			
		THE INFORMATION CONTAINED HEREIN IS PROPRIETARY DATA, AND IS NOT FOR DISSEMINATION OR DISCLOSURE, IN WHOLE OR IN PART, FOR ANY PURPOSE OTHER THAN THAT FOR WHICH IT IS SUBMITTED, EXCEPT AS AUTHORIZED IN WRITING BY FREIGHTLINER LLC.					
MATERIAL APPROVAL		DATE	UNLESS OTHERWISE NOTED, DIMENSIONS AND TOLERANCES ARE DEFINED ACCORDING TO ASME STANDARD Y14.5M-1994, WITH EXCEPTIONS PER FREIGHTLINER EDSM 09E0-K17.				
XXX	DATE	01/31/01					
DRAWN BY M. DAVIS	DATE	01/31/01					
CHECKED BY C. ZUBIETA	DATE	01/31/01					
RESPONSIBLE ENGINEER C. ZUBIETA	DATE	01/31/01	THIRD ANGLE PROJECTION	UNITS OF MEASURE MM			
APPROVED BY R. HENRY	DATE	01/31/01	NFO ENGR/PURCH AGENT M. PLUNCOCHAR	DATE	05/04/01		
DESCRIPTION HARN-JMPR, SIDE TURN/MRKR LAMP							
SUPPLEMENTARY DESCRIPTION 30003 GVG-M915, M916, M917							
ITEM/DRAWING NUMBER A06-39668				REVISION LETTER A	SHEET NUMBER 1 OF 1		







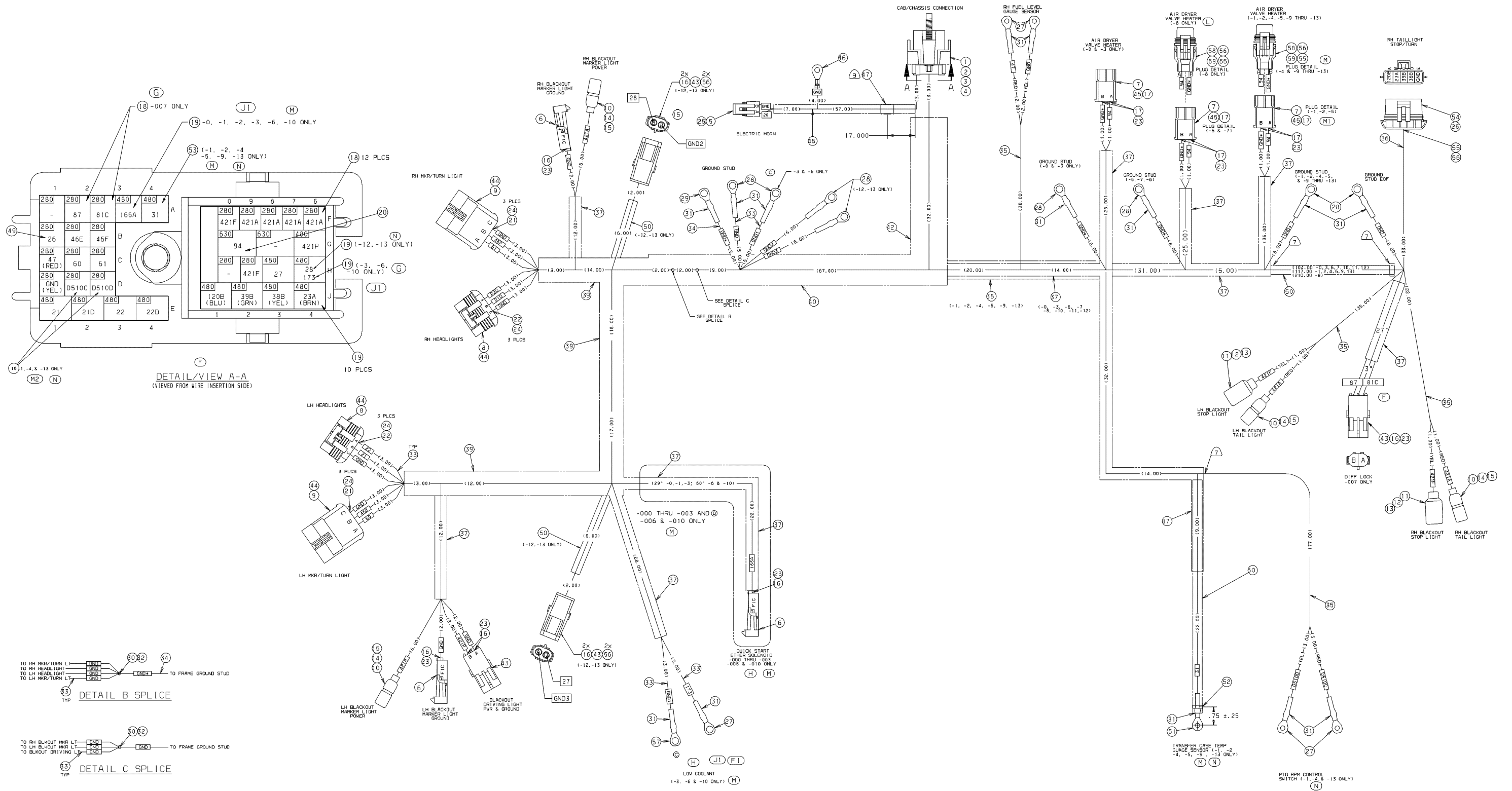



TM 9-2320-303-24-2

RELEASE NUMBER	REV LTR	ZONE	REVISION DESCRIPTION	BY	DATE	APPRO
P2703F-01	-	-	INITIAL RELEASE	KRH	09/23/94	BJD
PB1048-25	A	-	RMVD CIR D173;0953	MG	04/13/95	DJF
P3551J-06	B	-	LENGTHEN AIR DRYER FOR -002	ASR	07/18/96	KVM
			UPDATE VENDOR PART NUMBERS			
B39227-23	C	-	ADDED -003	TKC	08/26/96	KVM
P02600-03	D	-	ADDED -004, -005	JRT	06/17/97	KRH
			UPDATED ITEMS 17 & 25			
A75398-18	E	-	ADDED -006	VAS	04/15/98	RJH
B43922-29	F	-	ADDED -007	WJS	08/31/98	RJH
	F1	-	CHANGED NOTES			
B10592-73	G	-	NOTE UPDATES	WJS	09/16/98	RJH
B10592-75	H	-	LENGTHENED BREAKOUTS	WJS	09/18/98	RJH
P04508-U4	J	4E	ADD -006 TO CIRCUIT ++ NOTE	JRT	11/19/98	JLT
	J1	10C	DEL CIR 166A/173 FROM -007			
H50633-03	K	-	ADDED -008	JRT	02/26/00	JLT
H50633-13	L	-	-8:ADD 58 & 59;DEL 7 & 45	JRT	03/20/00	JLT
H58823-01	M	-	ADDED -9 THRU -11 & SHEET 2	JRT	05/02/00	JLT
	M1	6H	-004: ITEM 58 WAS ITEM 7			
	M2	9A	-1&4: ADDED D510C/D TO BULKHD			
P15259-01	N	--	ADDED -012 & -013 ASSEMBLIES	MOD	04/09/01	RJH
	N1	DI	ITEM 26 WAS PAC15300017			

	(N)	(N)	(M)	(M)	(M)	(K)	(F)	(E)	(D)	(D)	(C)			
1	1	1	1	1	1	1	1	1	1	1	1	PAC12034446	TERM, LK, SEC. 280 SPCL	59
1	1	1	1	1	1	1	1	1	1	1	1	PAC12020599	CONN, MALE MP280 SPCL	58
1	1	1	1	1	1	1	1	1	1	1	1	23-11194-114	TERM, RING+14AWG TO #8 STUD	57
11	11	7	7	7	7	6	5	5	7	5	5	PAC12015360	SEAL, CABLE, 14 G	56
7	7	7	7	7	7	6	5	5	7	5	5	PAC12129493	TERM, FEM MP 280, 14G	55
1	1	1	1	1	1	1	1	1	1	1	1	PAC12084891	CONN, MSC, 280 SRS	54
1	--	--	--	1	--	--	--	1	1	--	1	PAC12033820	TERM, BLD. M/M/P480SRS+12AWG	53
1	--	--	--	1	--	--	--	1	1	--	1	23-09795-309	STRAP, TIE	52
1	--	--	--	1	--	--	--	1	1	--	1	23-11194-210	TERM, RING+12AWG TO #10 STUD	51
16'	10'	9'	9'	15'	18'	9'	9'	15'	15'	9'	15'	48-02217-025	TUBE, CONVULATED, 1/4	50
1	1	1	1	1	1	1	1	1	1	1	1	PAC12034047	TERM, BLD. M/M/P280SRS+18AWG	49
6.5'	6.5'	6.5'	6.5'	6.5'	6.5'	6.5'	6.5'	6.5'	6.5'	6.5'	6.5'	48-02233-189	WIRE, #18 AWG, SXL, WHT	48
.5'	.5'	.5'	.5'	.5'	.5'	.5'	.5'	.5'	.5'	.5'	.5'	48-00126-012	TAPE, ELEC, RED	47
1	1	1	1	1	1	1	1	1	1	1	1	PAC12004433	TERM, RING 1/4	46
--	--	--	--	--	--	1	1	1	1	1	1	PAC15300014	TERM, LK, SEC. 2-POS 280 SLSRS	45
4	4	4	4	4	4	4	4	4	4	4	4	PAC12045699	TERM, LK, SEC. 3-POS 630 SLSRS	44
3	3	1	1	1	2	1	1	1	1	1	1	PAC12010973	HSG, 2-POS, W/P F2D	43
2.6'	2.6'	2.6'	2.6'	2.6'	2.6'	2.6'	2.6'	2.6'	2.6'	2.6'	2.6'	48-02217-125	TUBE, CONVULATED, 1.25	42
20'	15'	15'	15'	20'	15'	15'	15'	20'	20'	15'	20'	48-00126-007	TAPE, ELEC, BLACK	41
3.3'	3.3'	3.3'	3.3'	3.3'	3.3'	3.3'	3.3'	3.3'	3.3'	3.3'	3.3'	48-02217-100	TUBE, CONVULATED, 1"	40
6.6'	6.6'	6.6'	6.6'	6.6'	6.6'	6.6'	6.6'	6.6'	6.6'	6.6'	6.6'	48-02217-075	TUBE, CONVULATED, 3/4	39
2.8'	--	--	--	2.8'	--	--	--	2.8'	2.8'	--	--	48-02217-050	TUBE CONVULATED, 1/2	38
17.8'	15.5'	15.5'	21.0'	17.8'	14.0'	15.5'	21.0'	17.8'	17.8'	20.5'	22.0'	48-02217-038	TUBE CONVULATED, 3/8	37
20.3'	19.5'	19.5'	19.5'	20.3'	28'	19.5'	19.5'	20.3'	20.3'	19.5'	20.3'	48-02339-440	CABLE, FOURPLEX, #14 AWG	36
65.3'	45.6'	45.6'	45.6'	59.3'	63'	45.6'	45.6'	59.3'	45.6'	59.3'	65.3'	48-02339-240	CABLE, DUPLEX, #14 AWG	35
13.5'	13.5'	13.5'	13.5'	13.5'	13.5'	13.5'	13.5'	13.5'	13.5'	13.5'	13.5'	48-02223-129	WIRE, #12 AWG, SXL, WHT	34
249'	254'	223'	332'	218'	280'	337'	332'	218'	218'	240'	234'	48-02223-149	WIRE, #14 AWG, SXL, WHT	33
.4'	.4'	.4'	.4'	.4'	.4'	.4'	.4'	.4'	.4'	.4'	.4'	48-02461-038	TUBE, HEAT SHRINK, 3/8	32
1.4'	1.2'	1.2'	1.2'	1.4'	1.2'	1.2'	1.2'	1.4'	1.4'	1.4'	1.4'	48-02461-025	TUBE, HEAT SHRINK, 1/4	31
2	2	2	2	2	2	2	2	2	2	2	2	23-11283-000	TERM, SPLICE CLIP	30
1	1	1	1	1	1	1	1	1	1	1	1	23-11194-310	TERM, RING+12AWG TO 1/4 STUD	29
6	6	4	5	4	4	4	5	4	4	4	4	23-11194-314	TERM, RING+14AWG TO 1/4 STUD	28
4	2	2	3	2	2	2	3	2	4	3	2	23-11194-214	TERM, RING+14AWG TO #10 STUD	27
1	1	1	1	1	1	1	1	1	1	1	1	PAC15324857	TERM, LOCK, SECONDARY	26
1	1	1	1	1	1	1	1	1	1	1	1	PAC12162193	PLUG, MP150, M2M	25
11	12	12	12	11	12	12	12	11	11	12	12	PAC12059258	SEAL, WIRE, M/P BLUE 630 SRS	24
4	4	4	5	4	4	8	7	6	4	7	7	PAC12015359	SEAL, WIRE, M/P GR W/P 280M/P	23
6	6	6	6	6	6	6	6	6	6	6	6	PAC12052455	TERM, BLD, FEM M/P SEAL 630SRS	22
6	6	6	6	6	6	6	6	6	6	6	6	PAC12064735	TERM, BLD. M/M/P SEAL 630SRS	21
1	1	1	1	1	1	1	1	1	1	1	1	PAC12020126	TERM, BLD. M/M/P 630SRS 14AWG	20
9	9	9	11	9	9	9	11	9	9	11	10	PAC12020120	TERM, BLD. M/M/P 480SRS 14AWG	19
14	12	12	12	12	14	12	12	14	12	12	14	PAC12020116	TERM, BLD. M/M/P 280SRS 14AWG	18
--	--	--	--	--	--	2	2	2	--	2	2	PAC12048159	TERM, BLD. M/M/P 280SRS 16AWG	17
8	8	4	5	4	4	6	5	4	4	5	5	PAC12124582	TERM, PIN, MALE, W/P #4-16 AWG	16
4	4	4	4	4	4	4	4	4	4	4	4	ARU6338562	SLEEVE, INS, FEM TERM #14 AWG	15
4	4	4	4	4	4	4	4	4	4	4	4	ARU6338564	TERM, SOCKET, FEM #14 AWG	14
2	2	2	2	2	2	2	2	2	2	2	2	ARU6338567	LOCK, C-WASHER, TERM #14 AWG	13
2	2	2	2	2	2	2	2	2	2	2	2	ARU572929	TERM, PIN, MALE #14 AWG	12
2	2	2	2	2	2	2	2	2	2	2	2	ARU6338566	HSG, 1-POS, SEAL MS27142-2	11
4	4	4	4	4	4	4	4	4	4	4	4	ARU6338561	PLUG, 1-POS, SEAL MS27144-1	10
2	2	2	2	2	2	2	2	2	2	2	2	PAC12124686	HSG, 3-POS, M/P SEAL 630 SRS	9
2	2	2	2	2	2	2	2	2	2	2	2	PAC12124685	PLUG, 3-POS, M/P SEAL 630 SRS	8
--	--	--	--	--	--	1	1	1	--	1	1	PAC15300002	HSG, 2-POS, M, MP280	7
2	2	2	3	2	2	2	3	2	2	3	3	PAC12010996	HSG, 1-POS, W/P FIC	6
2	2	2	2	2	2	2	2	2	2	2	2	PAC12103881	TERMINAL, FEMALE	5
1	1	1	1	1	1	1	1	1	1	1	1	PAC12015969	LOCK, TERM, 16-POS	4
1	1	1	1	1	1	1	1	1	1	1	1	PAC12015968	LOCK, TERM, 18-POS	3
1	1	1	1	1	1	1	1	1	1	1	1	PAC12015966	CONN, HSG 16-POS(34POS BLKHD)	2
1	1	1	1	1	1	1	1	1	1	1	1	PAC12020128	CONN, HSG, 18-POS(34POS BLKHD)	1

LOWS:  
 +0.50/-0.00  
 +1.00/-0.00  
 +2.00/-0.00  
 PER FREIGHTLINER PROCESS SPEC #49-00051.  
 RE SHOWN IN RECTANGLES " " AND IN CONNECTOR T NUMBERS TO BE PRINTED EVERY 1 TO 6" ALONG WIRE.  
 OWN IN PARENTHESES "1" AND ARE MEASURED FROM CTOR/TERMINAL CENTERS.  
 PER FREIGHTLINER PROCESS SPEC #49-00052.  
 WRAPS OF ITEM 41 ELECTRICAL TAPE TO ALL JUNCTIONS AND OPENINGS. SECURE CONVULATED APPING TUBING WITH TAPE EVERY 6 TO 18 INCHES.  
 6 CABLE ALONG OUTSIDE OF ITEM 37, 38, AND 50 EVERY 6 TO 18 INCHES WITH ITEM 41 TAPE.  
 PIECE OF ITEM 31 OR 32 HEAT SHRINK TUBE ON ALL SHOWN.  
 TAPE AROUND HARNESS AS SHOWN.

DELIVERY MUST CONFORM EXACTLY WITH DRAWING SPECIFICATIONS AND, WHERE REQUIRED BY O.A., WITH APPROVED O.A. SAMPLES. ABSOLUTELY NO CHANGES ARE PERMITTED WITHOUT PRIOR APPROVAL BY FREIGHTLINER CORP. THIS INCLUDES CHANGES TO: INTERNAL COMPONENTS, MANUFACTURING PROCESSES.

QUANTITY	QUANTITY	QUANTITY	QUANTITY	QUANTITY	QUANTITY	QUANTITY	QUANTITY	QUANTITY	QUANTITY	QUANTITY	QUANTITY	QUANTITY	QUANTITY	QUANTITY	ITEM NUMBER	DESCRIPTION	REF

**FREIGHTLINER LLC**

THE INFORMATION CONTAINED HEREIN IS PROPRIETARY DATA, AND IS NOT FOR DISSEMINATION OR DISCLOSURE, IN WHOLE OR IN PART, FOR ANY PURPOSE OTHER THAN THAT FOR WHICH IT IS SUBMITTED, EXCEPT AS AUTHORIZED IN WRITING BY FREIGHTLINER LLC.

DATE	09/23/94
DESIGNED BY	09/23/94
DRWING CHECKED BY	09/23/94
APPROVED BY	09/23/94
DATE	09/23/94

UNLESS OTHERWISE NOTED, DIMENSIONS AND TOLERANCES ARE DEFINED ACCORDING TO ASME STANDARDS Y14.5M-1994, WITH EXCEPTIONS PER FREIGHTLINER EDSH 3800-K17.

DWG-HARN, CHS, M915/M916  
 SUPPLEMENTARY DESCRIPTION: 28801 CHS, FLD VARIOUS M91X  
 (DRAWING NUMBER) A06-22688 (REVISION LETTER) N (SHEET NUMBER) 1 OF 2





COLOR CODE	CIRCUIT NO. <sup>④</sup>	FUNCTION
BLU	120B	BACKUP LIGHT
BRN	23A	TAIL LIGHT
YEL	38B	LH TURN LIGHT
GRN	GND	LH GROUND

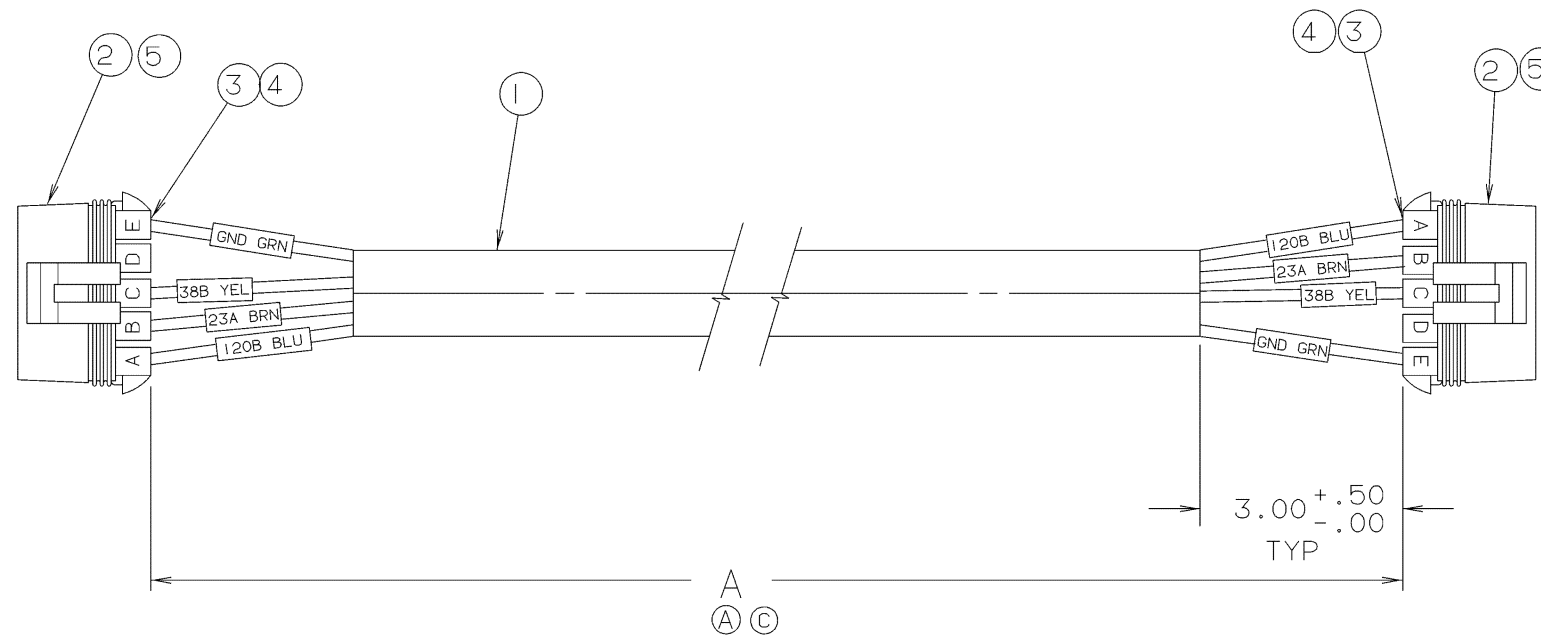

- ① INSTALL TERMINALS PER FREIGHTLINER SPEC 49-00052.
- ② STAMP OR LABEL OUTER CABLE JACKET AS REQUIRED.
- ③ TOLERANCE (ON BASIC DIM)  
 0.00 TO 11.99   +.50   -.00  
 12.00 TO 59.99   +1.00   -.00  
 60.00 AND UP   +2.00   -.00
- ④ CIR CALLOUTS FOR REF ONLY.

③	③	③	③	"A" - DIM				
②	2	2	2	PAC 15324857	LOCK-TERM, 5CAV MP280S, PLUG, BLK			5
④	8	8	8	23-12497-001	SEAL-CABLE, MP280-WP BLU, 14S-12			4
④	8	8	8	PAC 12129493	TERM, FEMALE, 280 M/P			3
②	2	2	2	681 545 31 28	PLUG, 4 WAY			2
①	38"	181"	66"	48-02339-440	CABLE, 4 COND, 14AWG			1
	-002	-001	-000	MFR. DASH NO.	PART NUMBER	NAME OF PART	MATERIAL	ITEM

LTR.	JOB NO.	DATE	BY	APPR.	FROM	CHANGE INFORMATION	TO
G	P17957-01	03-25-02	JEW	JEW MLC	WERE PAC12015360 AND PAC15324857		
F	P01358-07	06-08-99	JRT	JRT JLT	-002 FROM 30" TO 38"		
E	902164-09	08-11-97	JRT	GBJ KRH	ADDED -002		
D	P3550J-06	04-26-96	BDB	KRH	ITEMS 3 & 4 CHANGED		
C	499165-01	04-23-92	JRT	DHW CAM	ADDED -001 & "A" DIM		
B	P0003G	02-26-90	DDM	DDM DJL	ITEM 5 WAS 681 545 10 89		
A	P9242D	08-24-89	CD	DDM DJL	ITEM 1 66" WAS 60", DIM 66.00 REF WAS 60.00 REF, 60.00 WAS 54.00		

⑥ ③

**FREIGHTLINER LLC**  
PORTLAND, OREGON

THE INFORMATION CONTAINED HEREIN IS THE PROPRIETARY DATA OF FREIGHTLINER LLC AND IS NOT FOR DISSEMINATION OR DISCLOSURE IN WHOLE OR IN PART, FOR ANY PURPOSE OTHER THAN THAT FOR WHICH IT IS SUBMITTED EXCEPT AS AUTHORIZED IN WRITING BY FREIGHTLINER LLC.

THIRD ANGLE PROJECTION	UNLESS OTHERWISE NOTED UNITS = INCHES	DIMENSIONS AND TOLERANCES IN ACCORDANCE WITH ANSI Y14.5 - 1973 WITH EXCEPTIONS PER FREIGHTLINER E.O.M. SECTION 307	
DRAWN BY	RED	03-15-89	<b>ASSY, HARNESS-TAIL LIGHT</b> PRIMARY DESC. <b>GROTE</b> 2ND DESC. LOCATION MFR.
DFTG. CHECKED	DDM	03-15-89	
DESIGN APPROVAL	DDM	03-15-89	
MFG. APPROVAL	F. CROW	05-03-89	
FINAL APPROVAL	DJL	05-05-89	SCALE: FULL SHEET: 1 of 1 DRAWING NUMBER: A06-18319 CHG. LTR.: G



F/L CIR NO	SAE CIR NO	WIRE ITEM NO	FROM			TO			APPROX LENGTH -000	APPROX LENGTH -001	APPROX LENGTH -002	CIRCUIT DESCRIPTION
			LOC	TERM ITEM NO	SEAL INSL NO	CONN CAV POS	LOC	TERM ITEM NO				
39B	1316	1	1A	11	12	C	4	7	450	450	450	STOP/TURN SPLY, RH EOF
38B	1313	1	1A	11	12	D	6	7	950	950	950	STOP/TURN SPLY, LH EOF
120B	1322	1	1A	11	12	A	S3	2	700	700	700	BACK-UP LAMP SPLY
120B	1322	25	5	14	15	3	S3		925	925	925	BACK-UP LAMP SPLY
120B	1322	25	7	14	15	3	S3		350	350	350	BACK-UP LAMP SPLY
120B	1322	1	8	27	16		S3	3			525	BACK-UP LAMP SPLY
23A	1315	1	1A	11	12	B	S2	2	550	550	550	TAIL LP SPLY, TRAILER
23A	1315	1	4	7			S2	3	500	500	500	TAIL LP SPLY, TRAILER
23A	1315	1	6	7			S2	3	400	400	400	TAIL LP SPLY, TRAILER
GND	1204	1	1A	11	12	E	S1	2	400	400	400	GND, GENERAL CAB/CHASSIS
GND	1204	1	4	7			S1		350	350	350	GND, GENERAL CAB/CHASSIS
GND	1204	25	5	14	15	1	S1		625	625	625	GND, GENERAL CAB/CHASSIS
GND	1204	1	6	7			S1	3	550	550	550	GND, GENERAL CAB/CHASSIS
GND	1204	25	7	14	15	1	S1		650	650	650	GND, GENERAL CAB/CHASSIS
GND	1204	1	8	27	16		S1				825	GND, GENERAL CAB/CHASSIS
421A*	1303	1	2	13			4	7	750			BLACKOUT MARKER LP SPLY
421A	1303	1	3	13			6	7	900			BLACKOUT MARKER LP SPLY
421A*	1303	1	1B	23	12	A	4	7		450	450	BLACKOUT MARKER LP SPLY
421A	1303	1	1B	23	12	B	6	7			950	BLACKOUT MARKER LP SPLY
421F*	1316	1	2	7			4	7	750			BLACKOUT STOP LP, 24V
421F	1316	1	3	7			6	7	900			BLACKOUT STOP LP, 24V
421F*	1316	1	1B	23	12	C	4	7		450	450	BLACKOUT STOP LP, 24V
421F	1316	1	1B	23	12	D	6	7			950	BLACKOUT STOP LP, 24V

(C8) (B1)

(C8) (B1)

(B1) (C7)

(C7) (C7)

(C7) (C7)

(C7) (C7)

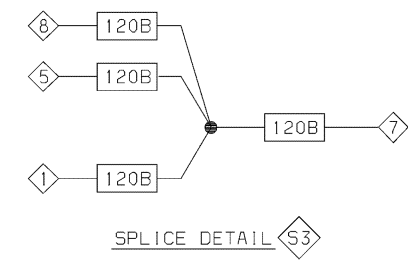
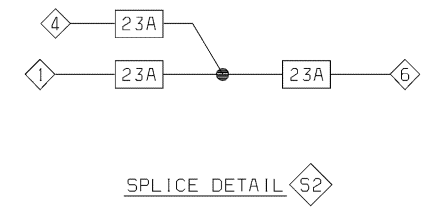
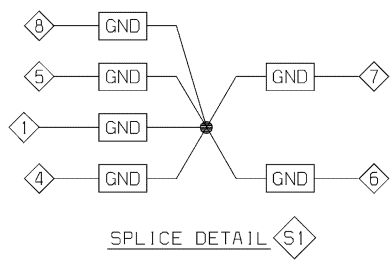
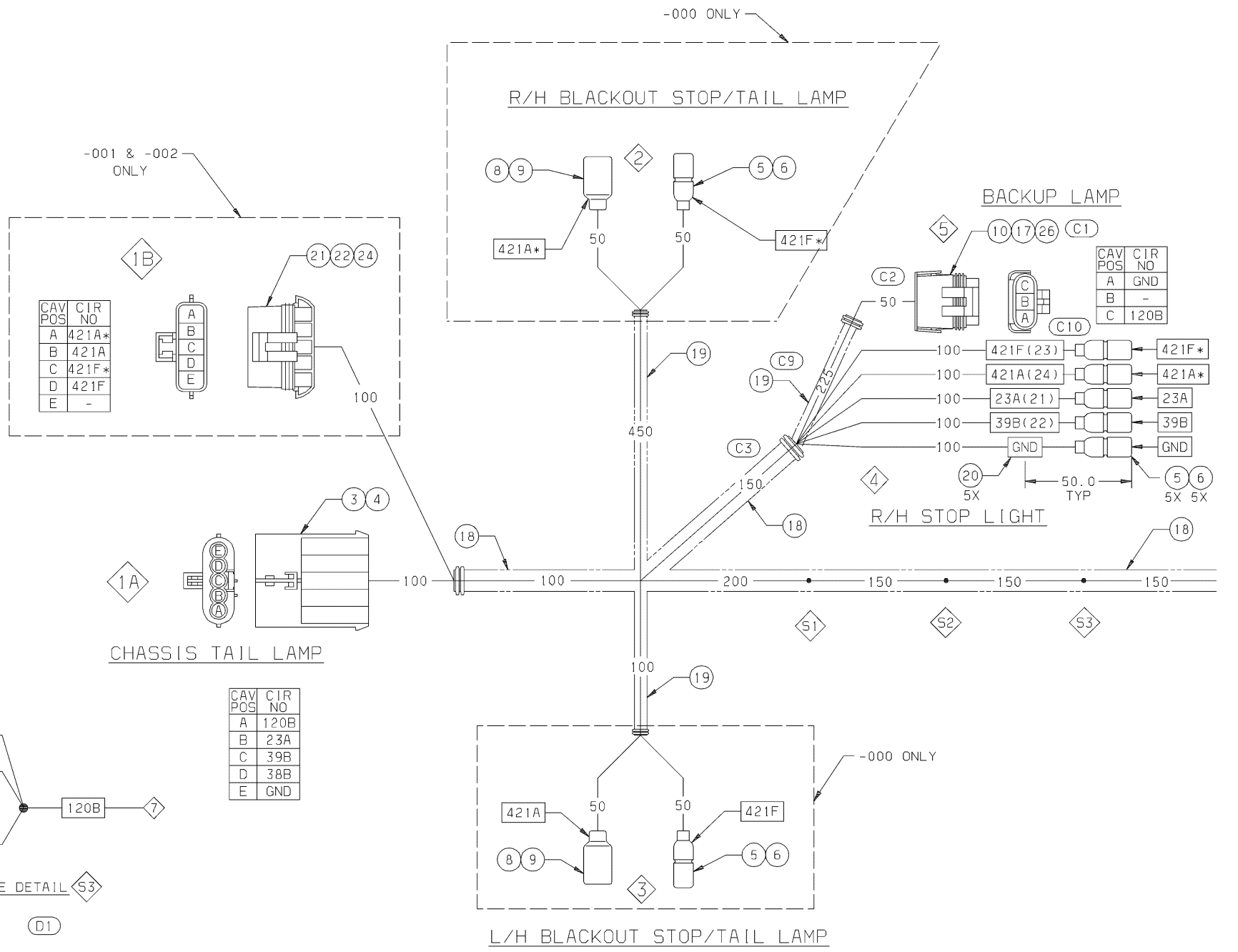

(D1)



RELEASE NUMBER	REV LTR	ZONE	REVISION DESCRIPTION	BY	DATE	APPD
P10107-13	-	XX	INITIAL RELEASE	MDD	01/03/01	RJH
P10107-18	A	A2	REVISED PART NUMBERS	MDD	02/09/01	RJH
P10107-42	B	A2	ADDED ITEM NO. 25			
	B1	D11	WIRE ITEM NUMBER WAS:1			
	B2	A3	-000 ITEM 1 QTY WAS 32.4' -001 ITEM 1 QTY WAS 30.7'	REN	03/08/01	RJH
P10107-84	C	C3	ADDED ITEM NO. 26	MDD	04/28/01	RJH
	C1	--	REPLACED AMP WITH PAC PART NO.			
	C2	C6/C4	DIM WAS 150			
	C3	C6	DIM WAS 50			
	C4	A3	-000 ITEM 1 QTY WAS 25.6'			
		A3	-001 ITEM 1 QTY WAS 24.1'			
	C5	C3	ITEM 25 QTY WAS 5.6'			
	C6	C3	ITEM 18 QTY WAS 2.6'			
	C7	--	ADDED 100MM TO OVERALL LENGTH			
	C8	--	ADDED 200MM TO OVERALL LENGTH			
	C9	--	ADDED CONVULUTE TO BACKUP LAMP BREAKOUT.			
	C10	--	REVISED LABELS: 23 WAS 24 24 WAS 23			
P10107-B1	D	C3	ADDED -002 HARN & ITEM 27	MDD	06/06/01	RJH
	D1	A9	REVISED SPLICE DETAILS			

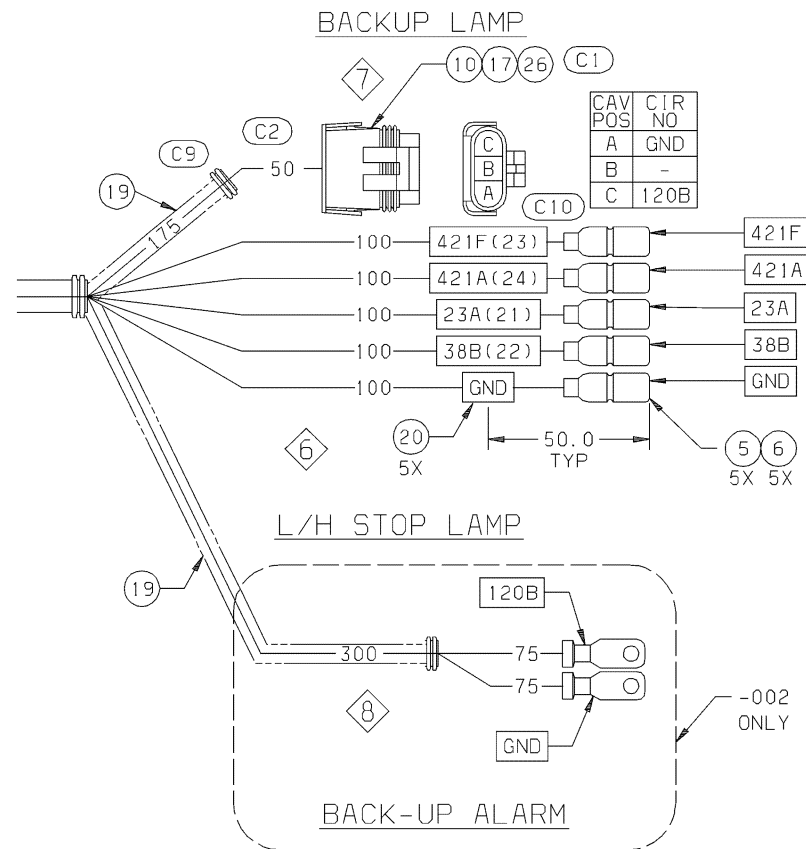

- 1 UNLESS OTHERWISE SPECIFIED, THIS ASSEMBLY MUST CONFORM TO FREIGHTLINER STANDARD 49-00106.
- 2 CONNECTOR END VIEWS ARE SHOWN FROM THE CABLE INSERTION END.
- 3 SEE SPLICE DETAIL.

(D)	2	-	-	23-11194-214	TERM-RING, #10 STUD, 14/16	27
(C)	2	2	2	PAC12059168	SEAL-CAVITY PLUG, MP150	26
(C5)	8.4'	8.4'	8.4'	48-02223-169	CABLE-SXL, 16GA, WHITE, LOW TNSN	25
(B)	1	1	-	PAC12010300	SEAL-CAVITY PLUG, MP280-WP, GRN	24
	4	4	-	PAC12129493	TERM-FEM, MP280S, 12-14AWG	23
	1	1	-	PAC12084891	PLUG-5CAV, MP280S, MD GRAY	22
	1	1	-	PAC15324857	LOCK-TERM, 5CAV, MP280S, PLUG, BLK	21
	10	10	10	PACR62979	LABEL	20
(C9)	2.3'	1.3'	1.8'	48-02217-025	CONDUIT-NYL, 6MM, FLEX, BLK, SLIT	19
(C6)	2.9'	2.9'	2.9'	48-02217-050	CONDUIT-NYL, 13MM, FLEX, BLK, SLIT	18
(C1)	2	2	2	PAC12052845	LOCK-TERM, 3CAV, MP150S-M & F	17
(C1)	5	3	3	48-02461-038	TUBE-HT SHRINK, 3/8", BLK, D-WALL	16
(C1)	4	4	4	PAC12052924	SEAL-CABLE, MP150, DK RED, REEL	15
(C1)	4	4	4	PAC12048074	TERM-FEM, MP150S, 16/18	14
	-	-	2	ARU572929	TERM-BULLET, MALE, #14	13
	9	9	5	PAC12015360	SEAL-CABLE, MP280-WP, BLUE, REEL	12
	5	5	5	PAC12129493	TERM-FEM, MP280S, 12-14AWG	11
(C1)	2	2	2	PAC12059595	PLUG-3CAV, MP150S, BLK	10
	-	-	2	ARU8338567	LOCK, C-WASHER, TERM, #14AWG	9
	-	-	2	ARU8338566	HOUSING-CONN, 1-PIN, FEM, #14	8
	10	10	12	ARU8338564	TERM-BULLET, FEM, #16-12, CLS BRL	7
	10	10	12	ARU8338562	INSULATOR SLEEVE, FEM TERM, #14	6
	10	10	12	ARU8338561	PLUG-CONN, 1-PIN, MALE, #14	5
	1	1	1	PAC12084673	LOCK-TERM, 5CAV, MP280S-RCPT	4
	1	1	1	PAC12186400	RCPT-5CAV, MP280S, GRAY	3
	5	3	3	PAC00821240	SPLICE CLIP, CABLE, 2.4-6.5 MM2	2
(C4)	29.5'	25.1'	26.7'	48-02223-149	CABLE-SXL, 14GA, WHITE, LOW TNSN	1
(B2)	QTY	QTY	QTY	ITEM NUMBER	DESCRIPTION	REF

ITEM NUMBER	DESCRIPTION	ITEM NUMBER	DESCRIPTION	ITEM NUMBER	DESCRIPTION
(D) A06-39306-002	HARN-JUMPER, TAILLIGHT	(A) A06-39306-001	HARN-JUMPER, TAILLIGHT	(A) A06-39306-000	HARN-JUMPER, TAILLIGHT

**DELIVERY MUST CONFORM EXACTLY WITH DRAWING SPECIFICATIONS AND, WHERE REQUIRED BY O.A., WITH APPROVED O.A. SAMPLES. ABSOLUTELY NO CHANGES ARE PERMITTED WITHOUT PRIOR APPROVAL BY FREIGHTLINER LLC. THIS INCLUDES CHANGES TO: SOFTWARE, MATERIALS, INTERNAL COMPONENTS, MANUFACTURING PROCESSES.**

**FREIGHTLINER LLC**

THE INFORMATION CONTAINED HEREIN IS PROPRIETARY DATA, AND IS NOT FOR DISSEMINATION OR DISCLOSURE, IN WHOLE OR IN PART, FOR ANY PURPOSE OTHER THAN THAT FOR WHICH IT IS SUBMITTED, EXCEPT AS AUTHORIZED IN WRITING BY FREIGHTLINER LLC.

MATERIAL APPROVAL XXX DATE XX/XX/XX	UNLESS OTHERWISE NOTED, DIMENSIONS AND TOLERANCES ARE DEFINED ACCORDING TO ASME STANDARD Y14.5M-1994, WITH EXCEPTIONS PER FREIGHTLINER EDSM 09E0-K17.
DRAWN BY M. DAVIS DATE 12/21/00	THIRD ANGLE PROJECTION
CHECKED BY C. ZUBIETA DATE 12/21/00	RESPONSIBLE ENGINEER C. ZUBIETA DATE 12/21/00
APPROVED BY R. HENRY DATE 12/21/00	MFG ENGR/PURCH AGENT M. PLUNCOCHAR DATE 06/06/01

DESCRIPTION: HARN-JUMPER, TAILLIGHT

SUPPLEMENTARY DESCRIPTION: 29402 GVG

ITEM/DRAWING NUMBER: A06-39306

REVISION LETTER: D

SHEET NUMBER: 1 OF 1



F/CIR	WIRE NO	FROM LOC	TO LOC	APPROX LENGTH	CIRCUIT DESCRIPTION
C2	14	29 3 26 44	4 23 44	92.00	CAB POWER-12V
	421V	25 3 34 44	4 23 44	58.00	CAB POWER-24V
	19	20 1 6 -	F4 2 12 44	63.00	ENGINE START
	150	20 1 6 -	G4 2 3 39 B	95.00	NEUTRAL SW LVD SIGNAL
C	160	29 24 37 44	4 26 44	113.00	ALTERNATOR 12V OUTPUT
	13C	19 1 3 -	H6 15 15 44	59.00	HOD ALARM
	30	19 1 4 -	F5 11 10 44	58.00	TRANS OIL TEMP SENSOR
	71AA	20 23 6 39	51 51 39	40.00	NEUTRAL SW PWR
	74	25 2 22 44	4 24 44	41.00	STARTER POWER
	82	25 2 22 44	4 23 44	39.00	HAG SW POWER
C	83	29 24 45 44	4 31 44	117.00	ALTERNATOR GND
	98A	19 1 4 -	D6 13 16 39 A	95.00	A/C COMPRESSOR CLUTCH
	99/71AA	20 1 6 -	B4 51 10 44	45.00	IGN ACC PWR
	99/71AA	20 6 12 44	51 10 44	27.00	FUEL SHUTDOWN SOLENOID
E1A	117	32 1 3 -	CA 12 14 39 A	111.00	SPEEDOMETER
	118	32 1 3 -	CS 12 14 39 B	111.00	SPEEDOMETER
	119	19 1 3 -	DA 14 17 35 A	100.00	WATER TEMP GAUGE SENSOR
C6	121A	19 1 4 -	A5 20 14 39 D	77.00	COMPRESSION BRAKE
	121B	19 1 4 -	A7 20 14 39 C	77.00	COMPRESSION BRAKE
	121C	19 1 4 -	B6 20 14 39 B	77.00	COMPRESSION BRAKE
	121D	19 1 4 -	B7 20 14 39 A	77.00	COMPRESSION BRAKE
E1A	162	32 1 3 -	CS 10 14 39 A	63.00	TACHOMETER
	163	32 1 3 -	C7 10 14 39 B	63.00	TACHOMETER
C	202	25 24 34 44	4 23 44	114.00	ALTERNATOR 24V OUTPUT
	234	19 1 4 -	F2 14 10 44	56.00	FAN CONTROL
	422A	20 21 8 39 A	1 7 -	A1 58.00	AUX MTR-FLAME DET SW
	422B	20 21 8 39 B	1 7 -	B1 58.00	AUX MTR-MOTOR PWR
	422C	20 21 8 39 C	1 7 -	F1 58.00	AUX MTR-POWER OUT
	422E	20 21 8 39 D	1 7 -	D1 58.00	AUX MTR-FLAME DET L1
	58E	19 1 3 -	C1 21 18 35 A	58.00	AUX MTR-WATER PUMP
	58E	19 1 3 -	C2 21 18 35 B	58.00	AUX MTR-FUEL PUMP
	GND	20 1 6 -	G2 21 6 39 C	98.00	AUX MTR-GND
E3	119B	19 24 24 44	14 17 25 B	67.00	MTR TMP GND
	71AA/118	19 23 40 39 A	23 40 39 B	6.00	NEUTRAL SW JUMPER

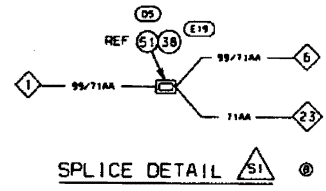
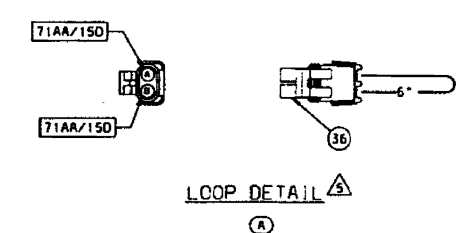
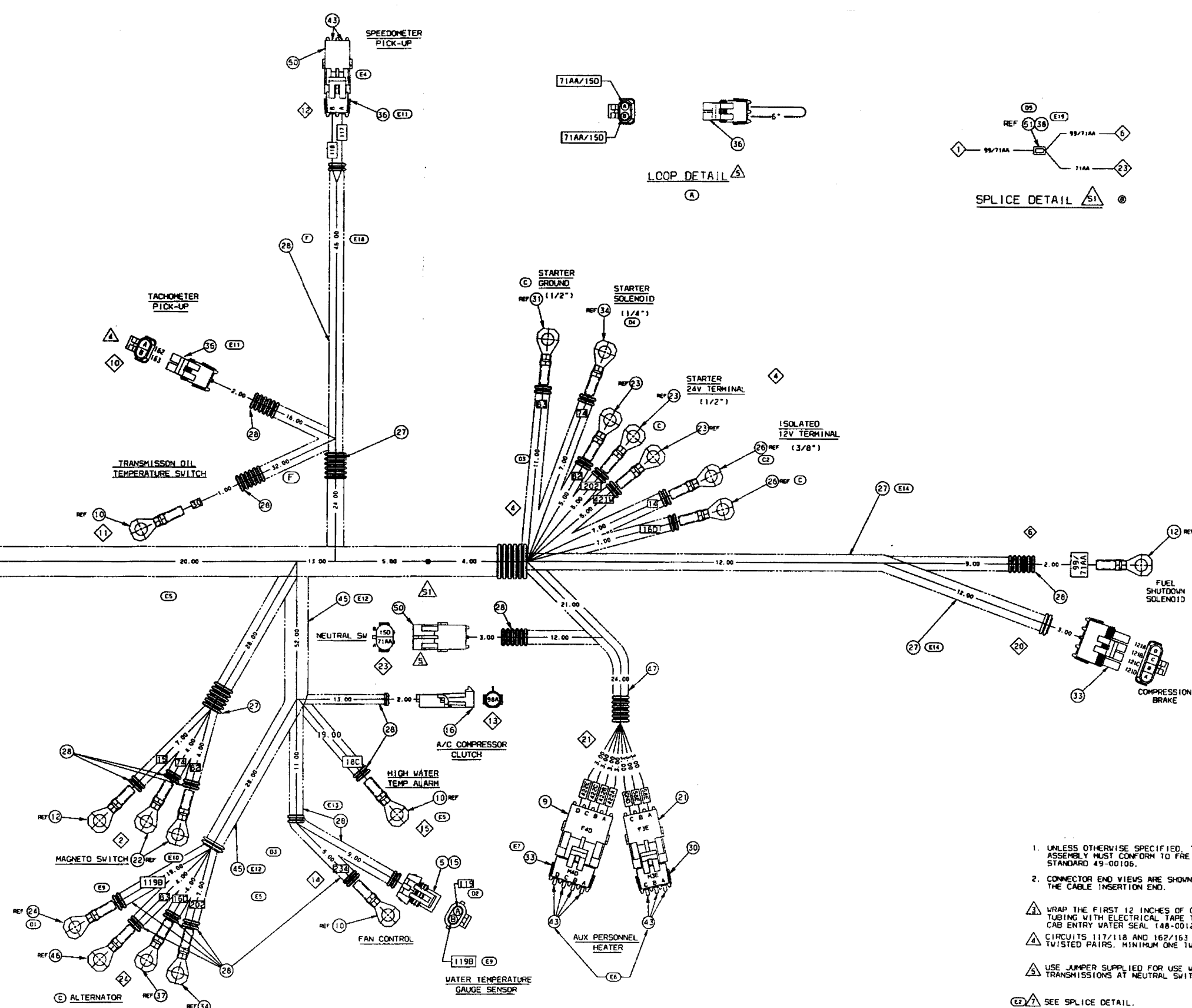
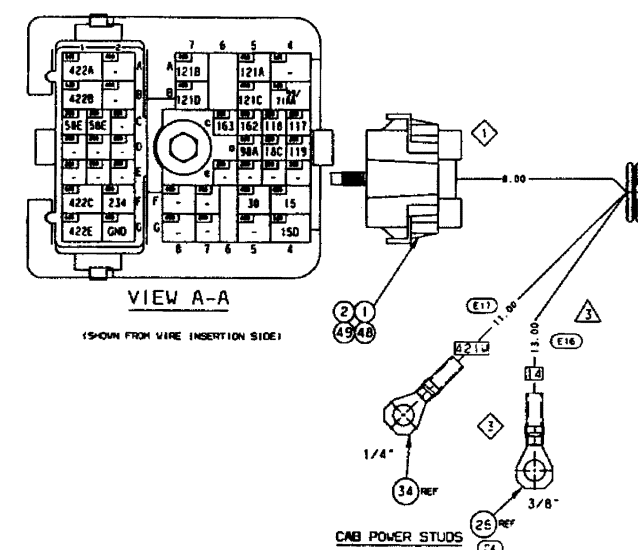

- UNLESS OTHERWISE SPECIFIED, THIS ASSEMBLY MUST CONFORM TO FREIGHTLINER STANDARD 49-00106.
  - CONNECTOR END VIEWS ARE SHOWN FROM THE CABLE INSERTION END.
  - WRAP THE FIRST 12 INCHES OF CONVOLUTED TUBING WITH ELECTRICAL TAPE TO PROVIDE CAB ENTRY WATER SEAL (48-00126-00B).
  - CIRCUITS 117/118 AND 162/163 ARE TO BE TWISTED PAIRS. MINIMUM ONE TWIST PER INCH.
  - USE JUMPER SUPPLIED FOR USE W/ VTEC 111 TRANSMISSIONS AT NEUTRAL SWITCH BREAKOUT.
- SEE SPLICE DETAIL.





F/L CIR NO	SAE CIR NO	WIRE ITEM NO	LOC	FROM	TO	APPROX LENGTH	CIRCUIT DESCRIPTION	
				TERMINAL NO	TERMINAL NO	-000		
15	1004	1	BHE	23	G6	2 27 37	1600 START SIG SW OUTPUT	
30	1405	1	BHE	24	A2	11 27 33	2280 TRANS OIL TEMP SIG MAIN GAUGE	
74	1004	2	4A	38 37	2A 36 37	-	1700 STARTER SOL SPLY	
82	1004	2	4B	36 37	2B 36 37	-	1650 MAG SV SPLY, STARTER	
119	1421	1	BHE	24	B1	14 29 32	A 2700 WTR TEMP GAUGE SIG CAB	
162	1406	1	BHE	24	B2	10 26 32	A 1880 TACHOMETER GAUGE + SIG. ENG RPM	
163	1406	1	BHE	24	B3	10 26 32	B 1880 TACHOMETER GAUGE - SIG. ENG RPM	
200	1413	1	BHE	24	C3	13B 29 32	A 1555 PTO IND LP SIG	
234	2202	1	BHE	23	A5	13 27 33	-	2500 FAN SOL SPLY, ENG
121A	1502	1	A1	38 31	S1 34 31	-	2380 ENG BK THROT SV SPLY, LKOUT	
121A	1502	1	BHE	23	J9	S1 73\ 73\	-	1180 ENG BK THROT SV SPLY, LKOUT
121A	1502	1	20	26 32	A S1 73\ 73\	-	775 ENG BK THROT SV SPLY, LKOUT	
121A	1502	1	6	27 33	S1 73\ 73\	-	700 ENG BK THROT SV SPLY, LKOUT	
121B	1502	1	BHE	23	J8	20 26 32	B 1955 ENG BK DASH SV #1 SPLY	
121C	1502	1	BHE	23	J7	20 26 32	C 1955 ENG BK SOL SPLY #1	
121D	1502	1	BHE	23	J6	20 26 32	D 1955 ENG BK SOL SPLY #2	
173	1420	1	LC1	27 31	BHE 24	-	H6 2550 WTR LEVEL IND LP SIG	
18C	1416	1	BHE	24	A3	15 27 33	-	2550 <OLD>HIGH WTR TEMP LAMP SPLY
200E	1510	1	BHE	24	C2	13A 26 32	A 1555 PTO SOL SPLY, TRANS	
200F	1510	1	BHE	24	C1	13B 29 32	B 1555 <OLD>PTO PRESS SW SPLY	
422A	2304	3	BHE	28	E4	21B	-	A 2555 <OLD>HTR 24V PWR SPLY
422B	2304	3	BHE	28	F3	21B	-	B 2555 <OLD>HTR 24V RUN PWR SPLY
422C	2304	3	BHE	28	F2	21B	-	C 2555 <OLD>HTR 24V HIGH PWR SPLY
422E	2304	3	BHE	28	E1	21B	-	D 2555 <OLD>HTR IND LP SIG
58E	2304	1	BHE	24	D1	21A 35 32	B 2555 <OLD>HTR HI/LD SW & PUMP SPLY	
58E	2304	1	BHE	24	D2	21A 35 32	A 2555 <OLD>HTR HI/LD SW & PUMP SPLY	
98A*	2301	1	BHE	24	D3	ACF 35 32	A 2450 HVAC, MAIN RES, LOW MOT SP SPLY	
GND	1204	3	BHE	28	A4	S2 34 31	-	1105 GND, GENERAL CAB/CHASSIS
GND	1204	3	21A	-	C	S2 73\ 73\	-	1450 GND, GENERAL CAB/CHASSIS
GND	1204	1	14	29 32	B	S2 73\ 73\	-	2405 GND, GENERAL CAB/CHASSIS
GND	1204	3	4	30 31	S2	73\ 73\	-	525 GND, GENERAL CAB/CHASSIS
GND	1204	1	13A	26 32	B	S2 73\ 73\	-	450 GND, GENERAL CAB/CHASSIS
GND	1204	1	LC2	27 31	-	S2 73\ 73\	-	2255 GND, GENERAL CAB/CHASSIS

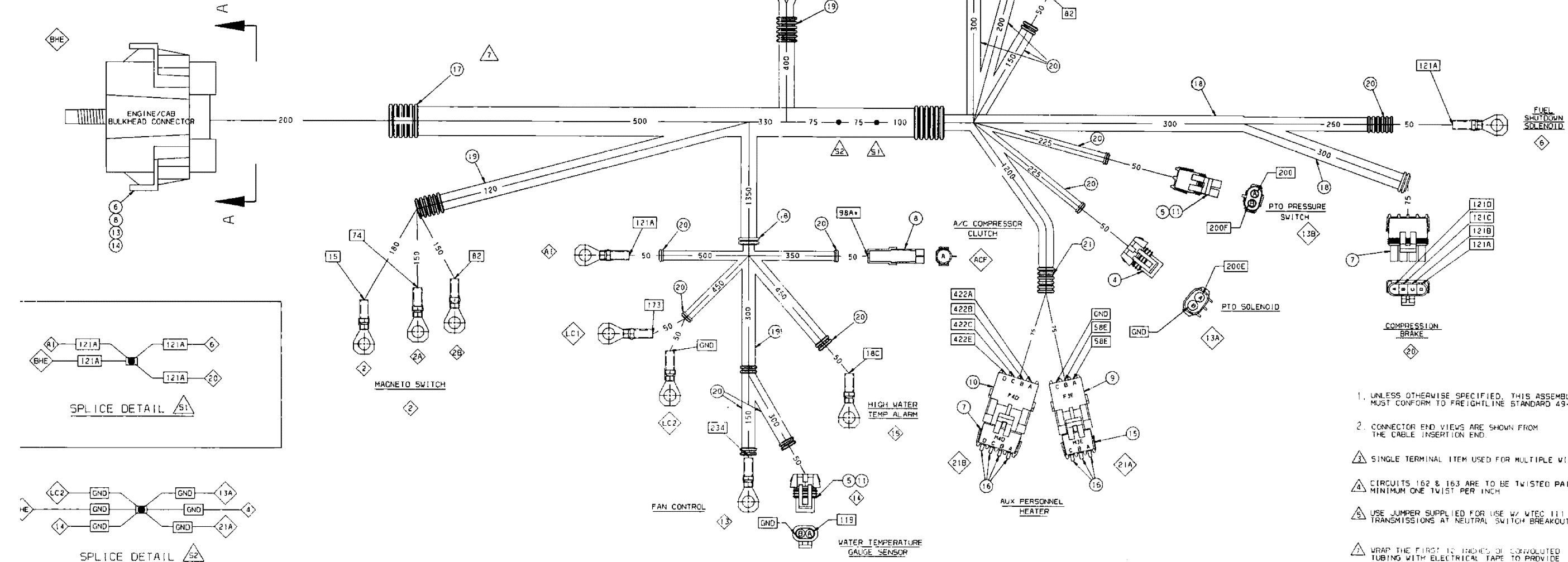
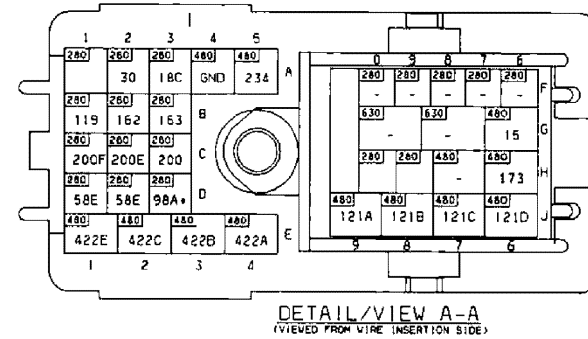

1. UNLESS OTHERWISE SPECIFIED, THIS ASSEMBLY MUST CONFORM TO FREIGHTLINE STANDARD 49-01
2. CONNECTOR END VIEWS ARE SHOWN FROM THE CABLE INSERTION END
3. SINGLE TERMINAL ITEM USED FOR MULTIPLE WIRE
4. CIRCUITS 162 & 163 ARE TO BE TWISTED PAIRS MINIMUM ONE TWIST PER INCH
5. USE JUMPER SUPPLIED FOR USE W/ WTEC 111 TRANSMISSIONS AT NEUTRAL SWITCH BREAKOUT
6. WRAP THE FIRST 10 INCHES OF CORROLATED TUBING WITH ELECTRICAL TAPE TO PROVIDE CAB ENTRY WATER SEAL (4A 00126 0081)



1 CABLE IS SUPPLIED BY THE MILITARY WITH (2) 3/8 LUG RING TERMINALS ON ONE END. REMOVE THE RING TERMS & INSTALL ITEMS 2 & 3 PER F/L SPEC 49-00052.

ⓑ ⓐ 2 APPROVED VENDOR PART NUMBER FOR A06-18163-000 IS ICR300591 (DASH 000 ONLY).

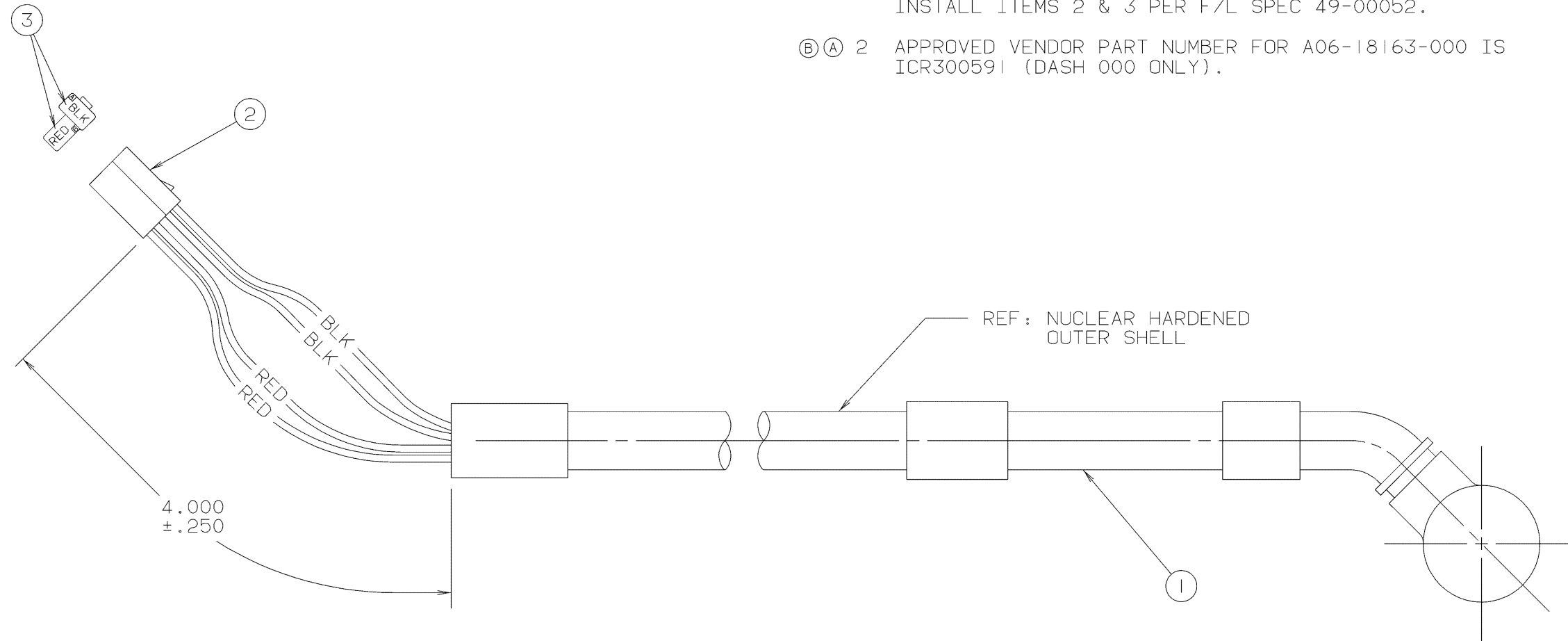

LTR.	JOB NO.	DATE	BY	APPR.	FROM	CHANGE INFORMATION	TO
B	PB1038-49	03-08-94	BUD	BUD KRH		ADDED -001 CHG NOTE 2 (-000 ONLY)	
A	P0273H-01	05-14-91	MGP	MGP KRH		ADDED NOTE 2.	
-	PB1000	03-21-89	MCH	DHW DN		INITIAL RELEASE	

QTY	UNIT	PART NUMBER	NAME OF PART	MATERIAL	ITEM	
2	2	23-11192-124	RCPT, FEM, 2-WIRE	2 X 14 AWG	3	
1	1	PAC 2973781	PLUG, 2-BLADE	M2A	2	
1		GFE A3014039-4	CABLE ASSY	5' LG	1	
	1	GFE A3014039-2	CABLE ASSY	13' LG	1	
-001	-000	MFR. DASH NO.	PART NUMBER	NAME OF PART	MATERIAL	ITEM

**FREIGHTLINER LLC**  
PORTLAND, OREGON

THE INFORMATION CONTAINED HEREIN IS THE PROPRIETARY DATA OF FREIGHTLINER LLC AND IS NOT FOR DISSEMINATION OR DISCLOSURE IN WHOLE OR IN PART, FOR ANY PURPOSE OTHER THAN THAT FOR WHICH IT IS SUBMITTED EXCEPT AS AUTHORIZED IN WRITING BY FREIGHTLINER LLC.

THIRD ANGLE PROJECTION UNLESS OTHERWISE NOTED UNITS = INCHES DIMENSIONS AND TOLERANCES IN ACCORDANCE WITH ANSI Y14.5 - 1973 WITH EXCEPTIONS PER FREIGHTLINER E.O.M. SECTION 307

CONTRACT NUMBER DAAE07-88-C-J915	DESIGN APPROVAL M.HARP 03-21-89	749 CABLE ASSY RADIO PRIMARY ITEM PRIMARY DESC.
FSCM 64678	MFG. APPROVAL NICHOLS 03-22-89	915/RADIO PWR CABLE ASSY LOCATION MFR. ADDITIONAL INFORMATION
SCALE FULL	SHEET 1 OF 1	DRAWING NUMBER A06-18163
		CHG. LTR. B



RELEASE NUMBER	REV LTR	ZONE	REVISION DESCRIPTION	BY	DATE	APPRO
P26619-09	-	-	INITIAL RELEASE	R2C	01/09/06	MIG

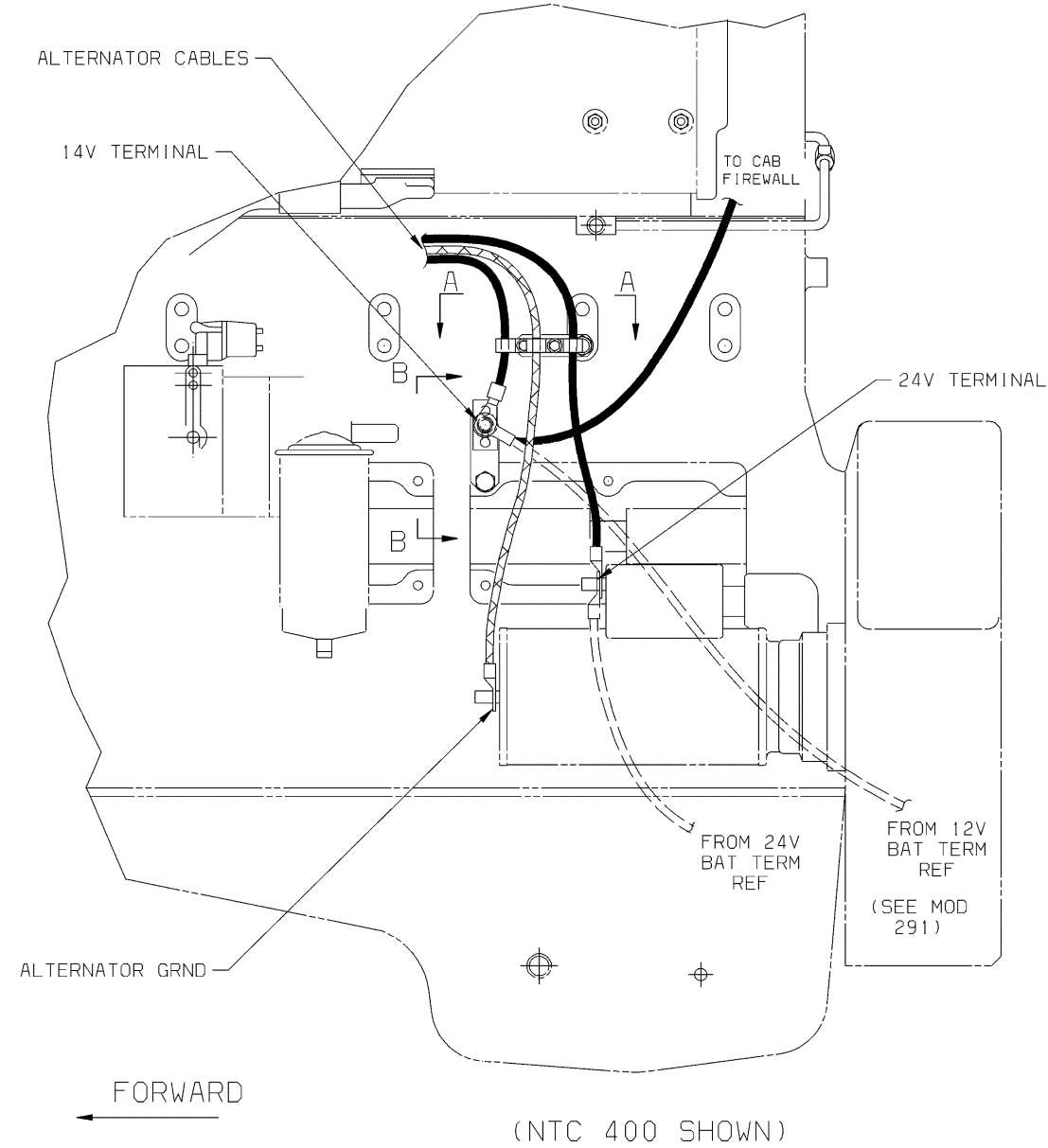

- 1 INSTALL ITEM 2 12V PWR TERM ON ITEM 1 BRKT AS SHOWN. MOUNT ITEM 1 BRKT TO ENG BLOCK USING EXISTING BOLT HOLE AND 9/16 UNF BOLT. MAY BE PROVIDED WITH ENGINE
- 2 SLIDE ITEM 8 BOOT OVER THE END OF THE 12 BATTERY CABLE, PRIOR TO INSTALLATION ON PWR TERM. INSURE THAT THE BAT CABLE IS ON TOP OF THE OTHER TERMINALS. SPRAY CONNECTION WITH ELECTRICAL SEALANT, AND POSITION THE BOOT OVER THE TERMINALS.

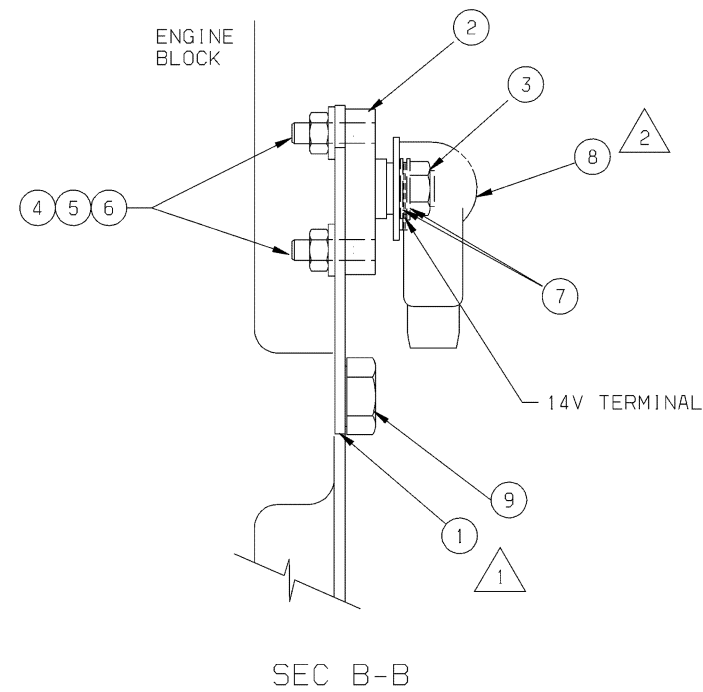
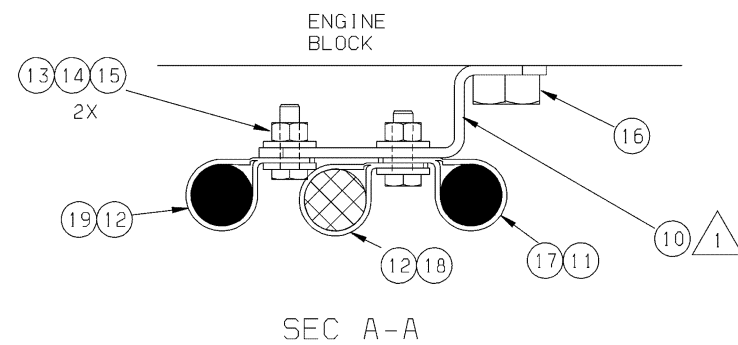

ITEM NUMBER		DATE		DATE		DATE	
D06-60573-000	DROWN BY	R. CACCIATORE	01/09/06	UNLESS OTHERWISE NOTED, DIMENSIONS AND TOLERANCES ARE DEFINED ACCORDING TO ASME STANDARD Y14.5M-1994, WITH EXCEPTIONS PER FREIGHTLINER E05M 09E0-K17.		THIRD ANGLE PROJECTION	
	CHECKED BY	M. GHITEA	01/09/06			UNITS OF MEASURE MM	
	RESPONSIBLE ENGINEER	M. GHITEA	01/09/06				
	APPROVED BY	M. GHITEA	01/09/06	MFG ENGR/PURCH AGENT	O. COLLETT	DATE	01/23/06
DESCRIPTION							
INSTL-12V PWR TERM, 12/24V ALT							
SUPPLEMENTARY DESCRIPTION							
125A1 GVG, M915A4R2							
ITEM/DRAWING NUMBER		D06-60573		REVISION LETTER		SHEET NUMBER	
				-		1 OF 1	



RELEASE NUMBER	REV	ZONE	REVISION DESCRIPTION	BY	DATE	APPD
P09074-01	-		INITIAL RELEASE	TMR	06/29/99	KVM
P09074-05	A		REVISED TITLE	VCR	08/05/99	RJH

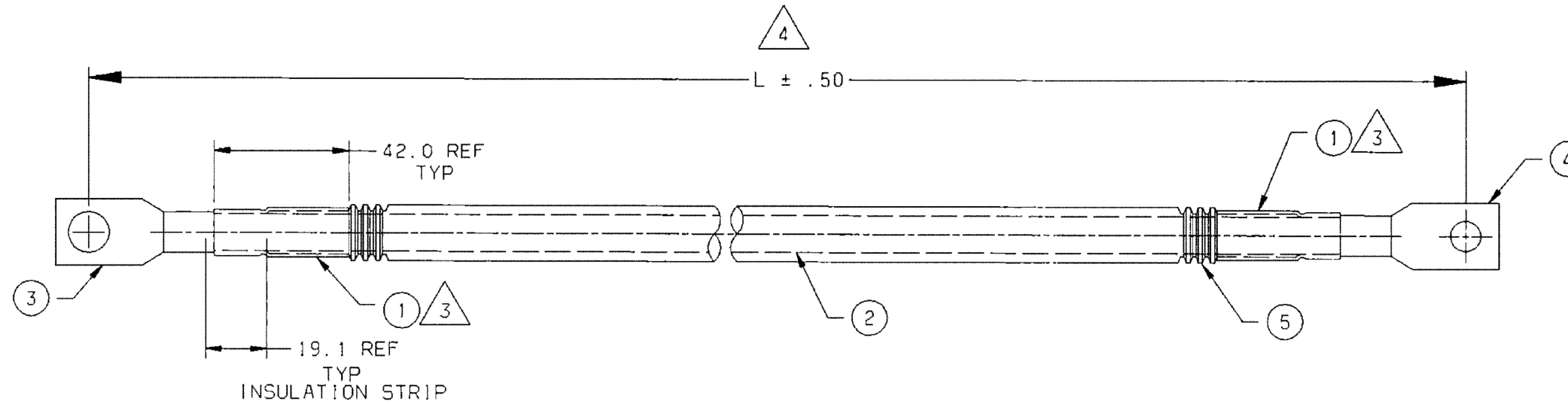

1. UNLESS OTHERWISE SPECIFIED, THIS ASSEMBLY MUST CONFORM TO FREIGHTLINER STANDARD 49-00052.
2. ASSEMBLY MUST WITHSTAND A MINIMUM PULL FORCE OF 450 LBS.
3. SHRINK INSULATOR OVER CONNECTION.
4. "L" = ASSY DASH NUMBER IN INCHES. EXAMPLE:  
A06-33246-108 HAS AN "L" DIMENSION OF 108 INCHES  
"L" DIMENSION OF -000 = "CUT TO FIT".
5. AS REQUIRED, APPROX 7 INCHES LESS THAN "L" DIMENSION.

5	48-25360-015	15MM RED CONVOLUTE TUBING	5
1	23-10379-023	TERM, LUG, BAT CABLE, 2/0, 3/8"	4
1	23-10379-021	TERM, LUG, BAT CABLE, 2/0, 1/2"	3
A/R	48-02252-000	CABLE-BATTERY/STARTER, RED, 2/0	2
2	06-14801-001	BATT CABLE INSULATOR	1
QUANTITY	ITEM NUMBER	DESCRIPTION	REF
<b>FREIGHTLINER LLC</b>			
THE INFORMATION CONTAINED HEREIN IS PROPRIETARY DATA, AND IS NOT FOR DISSEMINATION OR DISCLOSURE, IN WHOLE OR IN PART, FOR ANY PURPOSE OTHER THAN THAT FOR WHICH IT IS SUBMITTED, EXCEPT AS AUTHORIZED IN WRITING BY FREIGHTLINER LLC.			
MATERIAL APPROVAL		DATE	
DRAWN BY T. RAINFORTH		06/29/99	
CHECKED BY M. SCHATZ		06/30/99	
RESPONSIBLE ENGINEER M. SCHATZ		06/30/99	
APPROVED BY K. MCWILLIAMS		06/30/99	
UNLESS OTHERWISE NOTED, DIMENSIONS AND TOLERANCES ARE DEFINED ACCORDING TO ANSI STANDARD Y14.5M-1982, WITH EXCEPTIONS PER FREIGHTLINER EOM SECT 307		THIRD ANGLE PROJECTION	UNITS OF MEASURE MM
H/O ENGR/PURCH AGENT J. GOMEZ		DATE 08/05/99	
DESCRIPTION CABLE-POS. 2/0, RED, 1/2 X 3/8			
SUPPLEMENTARY DESCRIPTION 12501 2/0 OUTPUT			
ITEM NUMBER A06-33246-L	DESCRIPTION CABLE-POS. 2/0, RED, 1/2 X 3/8	REVISION LETTER A	SHEET NUMBER 1 OF 1





RELEASE NUMBER	REV LTR	ZONE	REVISION DESCRIPTION	BY	DATE	APPR
P09074-01	-		INITIAL RELEASE	TMR	06/29/99	KVM
P09074-05	A		REVISED TITLE	WCR	08/05/99	RJM

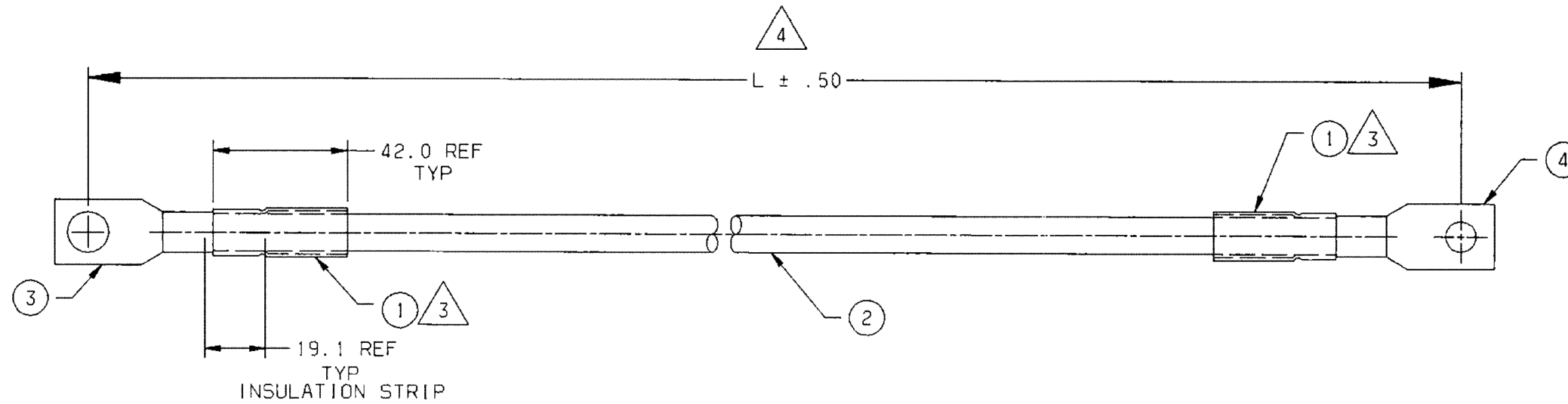

1. UNLESS OTHERWISE SPECIFIED, THIS ASSEMBLY MUST CONFORM TO FREIGHTLINER STANDARD 49-00052.
2. ASSEMBLY MUST WITHSTAND A MINIMUM PULL FORCE OF 450 LBS.
- 3 SHRINK INSULATOR OVER CONNECTION.
- 4 "L" = ASSY DASH NUMBER IN INCHES. EXAMPLE:  
A06-33247-108 HAS AN "L" DIMENSION OF 108 INCHES  
"L" DIMENSION OF -000 = "CUT TO FIT".
- 5 AS REQUIRED, APPROX 7 INCHES LESS THAN "L" DIMENSION.

1	23-10379-023	TERM, LUG, BAT CABLE, 2/0, 3/8"	4
1	23-10379-021	TERM, LUG, BAT CABLE, 2/0, 1/2"	3
A/R	48-02230-000	CABLE-BATTERY/STARTER, BK, 2/0	2
2	06-14801-001	BATT CABLE INSULATOR	1
QUANTITY	ITEM NUMBER	DESCRIPTION	REF
<b>FREIGHTLINER LLC</b>			
THE INFORMATION CONTAINED HEREIN IS PROPRIETARY DATA, AND IS NOT FOR DISSEMINATION OR DISCLOSURE, IN WHOLE OR IN PART, FOR ANY PURPOSE OTHER THAN THAT FOR WHICH IT IS SUBMITTED, EXCEPT AS AUTHORIZED IN WRITING BY FREIGHTLINER LLC.			
MATERIAL APPROVAL		DATE	
DRAWN BY T. RAINFORTH		06/29/99	
CHECKED BY H. SCHATZ		06/30/99	
RESPONSIBLE ENGINEER M. SCHATZ		06/30/99	
APPROVED BY K. MCWILLIAMS		06/30/99	
UNLESS OTHERWISE NOTED, DIMENSIONS AND TOLERANCES ARE DEFINED ACCORDING TO ANSI STANDARD Y14.5M-1982, WITH EXCEPTIONS PER FREIGHTLINER EDM SECT 307.		THIRD ANGLE PROJECTION	
		UNITS OF MEASURE MM	
MFG ENGR/PURCH AGENT J. GOMEZ		DATE 7/2/99	
DESCRIPTION CABLE-NEG, 2/0, BLK, 1/2 X 3/8			
SUPPLEMENTARY DESCRIPTION 12501 2/0 OUTPUT			
ITEM/DRAWING NUMBER A06-33247	REVISION LETTER A	SHEET NUMBER 1 OF 1	



## INDEX

<i>Subject</i>	<i>Work Package/Page</i>
<b>A</b>	
Air Conditioner	
Compressor Replacement .....	0302 00-1
Compressor Service .....	0301 00-1
Condenser Replacement .....	0304 00-1
Evaporator Coil Replacement .....	0300 00-1
Expansion Valve Replacement .....	0299 00-1
Hose Replacement .....	0305 00-1
Receiver-Dryer Replacement .....	0303 00-1
Air Conditioning System	
Refrigerant (R-134A) Maintenance .....	0297 00-1
Troubleshooting and Testing, Direct Support .....	0227 00-1
Air Dryer Repair .....	0262 00-1
Air Ducts Replacement .....	0296 00-1
Alternator Repair .....	0233 00-1
Anti-lock Brake System (ABS)	
Wiring Harness Replacement	
Front .....	0242 00-1
Rear .....	0243 00-1
Axle	
Caster Adjustment, Front .....	0250 00-1
Replacement, Front .....	0249 00-1
Replacement, Rear .....	0255 00-1
<b>B</b>	
Brake Drum Repair .....	0263 00-1
<b>C</b>	
Cab	
Alligator Crossmember Replacement .....	0273 00-1
Mounts Replacement, Front .....	0280 00-1
Mounts Replacement, Rear .....	0281 00-1
Replacement .....	0290 00-1
Cab Body Repair .....	0289 00-1
Cab Door	
Repair .....	0293 00-1
Replacement .....	0292 00-1
Chassis Wiring Harness Replacement .....	0241 00-1
Collision Warning System (CWS) Wiring Harness Replacement .....	0247 00-1
Cross Tube Arm Replacement, Front .....	0252 00-1

## INDEX - Continued

*Subject* *Work Package/Page*

### C - Continued

Crossmember	
Replacement, Front .....	0277 00-1
Replacement, Rear .....	0276 00-1

### D

Differential Carrier Repair	
Forward-Rear Axle .....	0257 00-1
Rear-Rear Axle .....	0259 00-1
Differential Carrier Replacement	
Forward-Rear Axle .....	0256 00-1
Rear-Rear Axle .....	0258 00-1

### E

Engine	
Mount Support Replacement, Front .....	0279 00-1
Mounts Replacement .....	0230 00-1
Removal .....	0229 00-1
Troubleshooting, Direct Support .....	0224 00-1
Wiring Harness Replacement .....	0245 00-1
Equalizing Beam	
Repair .....	0288 00-1
Replacement .....	0287 00-1
Expendable and Durable Items List .....	0312 00-1

### F

Fan Clutch Repair .....	0232 00-1
Fifth Wheel	
Replacement .....	0267 00-1
Top Plate Repair .....	0270 00-1
Top Plate Replacement .....	0269 00-1
Foot Brake Valve Repair .....	0261 00-1
Forward-Rear Axle Differential Carrier Repair .....	0257 00-1
Forward-Rear Axle Differential Carrier Replacement .....	0256 00-1
Frame Rail Extension and Reinforcement Replacement .....	0278 00-1

### G

General Maintenance Instructions .....	0306 00-1
--	-----------

### H

Heating, Ventilation, Air Conditioning (HVAC) Unit Replacement .....	0298 00-1
Hood Sheet Molded Compound (SMC) Repair .....	0291 00-1

## INDEX - Continued

<i>Subject</i>	<i>Work Package/Page</i>
<b>I</b>	
Illustrated List of Manufactured Items .....	0310 00-1
<b>M</b>	
Main Cab Wiring Harness Replacement .....	0236 00-1
Maintenance Allocation Chart (MAC) .....	0309 00-1
Maintenance Allocation Chart (MAC) Introduction .....	0308 00-1
Midships Alligator Crossmember Replacement .....	0274 00-1
<b>O</b>	
Overhead Cab Wiring Harness Replacement .....	0240 00-1
Overslung Crossmember Replacement .....	0272 00-1
<b>P</b>	
Power Pack Replacement .....	0228 00-1
Power Steering Pump Replacement .....	0264 00-1
Preliminary Troubleshooting Procedures .....	0222 00-1
<b>R</b>	
Radiator Repair .....	0231 00-1
Radio Wiring Harness Replacement .....	0246 00-1
Ramp Replacement .....	0271 00-1
Rear-Rear Axle Differential Carrier Repair .....	0259 00-1
Rear-Rear Axle Differential Carrier Replacement .....	0258 00-1
References .....	0307 00-1
<b>S</b>	
Slide Bracket and Plate Repair .....	0268 00-1
Spring and Saddle Assembly Replacement, Rear .....	0284 00-1
Spring Hangers Replacement, Front .....	0283 00-1
Spring Hangers Replacement, Rear .....	0285 00-1
Spring Replacement, Front .....	0282 00-1
Starter	
Repair .....	0235 00-1
Solenoid Replacement .....	0234 00-1

## INDEX - Continued

*Subject* *Work Package/Page*

### S - Continued

Steering	
Arm Replacement, Front .....	0253 00-1
Column Replacement .....	0266 00-1
Gear Replacement .....	0265 00-1
Knuckle Replacement, Front .....	0254 00-1
System Troubleshooting, Direct Support .....	0226 00-1
Suspension Crossmember Replacement, Rear .....	0275 00-1
Switch Panel Wiring Harness Replacement .....	0237 00-1

### T

Taillight Wiring Harness Replacement .....	0244 00-1
Tie Rod Maintenance .....	0251 00-1
Tool Identification List .....	0313 00-1
Torque Limits .....	0311 00-1
Torque Rod Replacement .....	0286 00-1
Transmission	
Overhaul .....	0248 00-1
Troubleshooting, Direct Support .....	0225 00-1
Troubleshooting, Direct Support	
Air Conditioning System .....	0227 00-1
Engine .....	0224 00-1
Introduction .....	0222 00-1
Steering System .....	0226 00-1
Symptom Index .....	0223 00-1
Transmission .....	0225 00-1
Turn Signal (Thru-Deck) Wiring Harness Replacement .....	0239 00-1
Turn Signal/Marker Light Wiring Harness Replacement .....	0238 00-1

### W

Window Replacement, Rear .....	0295 00-1
Windshield Replacement .....	0294 00-1
Wiring Harness Replacement	
Chassis .....	0241 00-1
Collision Warning System (CWS) .....	0247 00-1
Engine .....	0245 00-1
Front Anti-lock Brake System (ABS) .....	0242 00-1
Main Cab .....	0236 00-1
Overhead Cab .....	0240 00-1
Radio .....	0246 00-1

## INDEX - Continued

*Subject*

*Work Package/Page*

### W - Continued

Wiring Harness Replacement - Continued	
Rear Anti-Lock Brake System (ABS) .....	0243 00-1
Switch Panel .....	0237 00-1
Taillight .....	0244 00-1
Turn Signal (Thru-Deck) .....	0239 00-1
Turn Signal/Marker Light .....	0238 00-1

### Y

Yoke and Oil Seal Replacement, Rear .....	0260 00-1
---	-----------





<p><b>RECOMMENDED CHANGES TO PUBLICATIONS AND BLANK FORMS</b></p> <p>For use of this form, see AR 25-30; the proponent agency is ODISC4.</p>	<p>Use Part II (<i>reverse</i>) for Repair Parts and Special Tool Lists (RPSTL) and Supply Catalogs/Supply Manuals (SC/SM).</p>	<p>DATE</p> <p>01 July 2008</p>
--	---	---------------------------------

<p>TO: (<i>Forward to proponent of publication or form</i>) (<i>Include ZIP Code</i>)</p> <p>AMSTA-LC-LPIT/TECH PUBS, TACOM-RI 1 Rock Island Arsenal Rock Island, IL 61299-7630</p>	<p>FROM: (<i>Activity and location</i>) (<i>Include ZIP Code</i>)</p> <p>125th Transportation Company ATTN: Motor SGT (SGT Wilson) Ft. Riley, KA 78665-4000</p>
---	---

**PART I - ALL PUBLICATIONS (EXCEPT RPSTL AND SC/SM) AND BLANK FORMS**

<p>PUBLICATION/FORM NUMBER</p> <p>TM 9-2320-303-24-2</p>	<p>DATE</p> <p>30 December 2005</p>	<p>TITLE</p> <p>Unit and Direct Support Maintenance Manual for M915A4/M915A4R2 Tractor Truck</p>
--	-------------------------------------	--

ITEM	PAGE	PARA-	LINE	FIGURE NO.	TABLE	RECOMMENDED CHANGES AND REASON
	0035 00-1	Initial Setup				Item number for Oil, Lubricating is not correct.

SAMPLE

*\* Reference to line numbers within the paragraph or subparagraph.*

<p>TYPED NAME, GRADE OR TITLE</p> <p>Johnny Wilson, E-5, MOTOR SGT</p>	<p>TELEPHONE EXCHANGE/AUTOVON, PLUS EXTENSION</p> <p>DSN 867-7967</p>	<p>SIGNATURE</p>
--	---	------------------

TO: (Forward direct to addressee listed in publication)

FROM: (Activity and location) (Include ZIP Code)

DATE

**PART II - REPAIR PARTS AND SPECIAL TOOL LISTS AND SUPPLY CATALOGS/SUPPLY MANUALS**

PUBLICATION NUMBER

DATE

TITLE

PAGE NO.	COLM NO.	LINE NO.	NATIONAL STOCK NUMBER	REFERENCE NO.	FIGURE NO.	ITEM NO.	TOTAL NO. OF MAJOR ITEMS SUPPORTED	RECOMMENDED ACTION
----------	----------	----------	-----------------------	---------------	------------	----------	------------------------------------	--------------------

**SAMPLE**

**PART III - REMARKS**

*(Use this section for remarks, references, or suggestions for improvement of publications and for additional sheets not to be used.)*

TYPED NAME, GRADE OR TITLE

TELEPHONE EXCHANGE/AUTOVON, PLUS EXTENSION

SIGNATURE

<b>RECOMMENDED CHANGES TO PUBLICATIONS AND BLANK FORMS</b> For use of this form, see AR 25-30; the proponent agency is ODISC4.	Use Part II ( <i>reverse</i> ) for Repair Parts and Special Tool Lists (RPSTL) and Supply Catalogs/Supply Manuals (SC/SM).	DATE
---	--	------

TO: ( <i>Forward to proponent of publication or form</i> ) ( <i>Include ZIP Code</i> ) AMSTA-LC-LPIT/TECH PUBS, TACOM-RI 1 Rock Island Arsenal Rock Island, IL 61299-7630	FROM: ( <i>Activity and location</i> ) ( <i>Include ZIP Code</i> )
--	--

**PART I - ALL PUBLICATIONS (EXCEPT RPSTL AND SC/SM) AND BLANK FORMS**

PUBLICATION/FORM NUMBER TM 9-2320-303-24-2	DATE 30 December 2005	TITLE Unit and Direct Support Maintenance Manual for M915A4/M915A4R2 Tractor Truck
---	--------------------------	---

ITEM	PAGE	PARA-	LINE	FIGURE NO.	TABLE	RECOMMENDED CHANGES AND REASON

*\* Reference to line numbers within the paragraph or subparagraph.*

TYPED NAME, GRADE OR TITLE	TELEPHONE EXCHANGE/AUTOVON, PLUS EXTENSION	SIGNATURE
----------------------------	--	-----------

<b>TO:</b> <i>(Forward direct to addressee listed in publication)</i>	<b>FROM:</b> <i>(Activity and location) (Include ZIP Code)</i>	<b>DATE</b>
---	--	-------------

**PART II - REPAIR PARTS AND SPECIAL TOOL LISTS AND SUPPLY CATALOGS/SUPPLY MANUALS**

PUBLICATION NUMBER			DATE			TITLE		
PAGE NO.	COLM NO.	LINE NO.	NATIONAL STOCK NUMBER	REFERENCE NO.	FIGURE NO.	ITEM NO.	TOTAL NO. OF MAJOR ITEMS SUPPORTED	RECOMMENDED ACTION

**PART III - REMARKS** *(Any general remarks or recommendations, or suggestions for improvement of publications and blank forms. Additional blank sheets may be used if more space is needed.)*

TYPED NAME, GRADE OR TITLE	TELEPHONE EXCHANGE/AUTOVON, PLUS EXTENSION	SIGNATURE
----------------------------	--	-----------



<b>TO:</b> <i>(Forward direct to addressee listed in publication)</i>	<b>FROM:</b> <i>(Activity and location) (Include ZIP Code)</i>	<b>DATE</b>
---	--	-------------

**PART II - REPAIR PARTS AND SPECIAL TOOL LISTS AND SUPPLY CATALOGS/SUPPLY MANUALS**

PUBLICATION NUMBER			DATE			TITLE		
PAGE NO.	COLM NO.	LINE NO.	NATIONAL STOCK NUMBER	REFERENCE NO.	FIGURE NO.	ITEM NO.	TOTAL NO. OF MAJOR ITEMS SUPPORTED	RECOMMENDED ACTION

**PART III - REMARKS** *(Any general remarks or recommendations, or suggestions for improvement of publications and blank forms. Additional blank sheets may be used if more space is needed.)*

TYPED NAME, GRADE OR TITLE	TELEPHONE EXCHANGE/AUTOVON, PLUS EXTENSION	SIGNATURE
----------------------------	--	-----------

<b>RECOMMENDED CHANGES TO PUBLICATIONS AND BLANK FORMS</b> For use of this form, see AR 25-30; the proponent agency is ODISC4.	Use Part II ( <i>reverse</i> ) for Repair Parts and Special Tool Lists (RPSTL) and Supply Catalogs/Supply Manuals (SC/SM).	DATE
---	--	------

TO: ( <i>Forward to proponent of publication or form</i> ) ( <i>Include ZIP Code</i> ) AMSTA-LC-LPIT/TECH PUBS, TACOM-RI 1 Rock Island Arsenal Rock Island, IL 61299-7630	FROM: ( <i>Activity and location</i> ) ( <i>Include ZIP Code</i> )
--	--

**PART I - ALL PUBLICATIONS (EXCEPT RPSTL AND SC/SM) AND BLANK FORMS**

PUBLICATION/FORM NUMBER TM 9-2320-303-24-2	DATE 30 December 2005	TITLE Unit and Direct Support Maintenance Manual for M915A4/M915A4R2 Tractor Truck
---	--------------------------	---

ITEM	PAGE	PARA-	LINE	FIGURE NO.	TABLE	RECOMMENDED CHANGES AND REASON

*\* Reference to line numbers within the paragraph or subparagraph.*

TYPED NAME, GRADE OR TITLE	TELEPHONE EXCHANGE/AUTOVON, PLUS EXTENSION	SIGNATURE
----------------------------	--	-----------

<b>TO:</b> <i>(Forward direct to addressee listed in publication)</i>	<b>FROM:</b> <i>(Activity and location) (Include ZIP Code)</i>	<b>DATE</b>
---	--	-------------

**PART II - REPAIR PARTS AND SPECIAL TOOL LISTS AND SUPPLY CATALOGS/SUPPLY MANUALS**

PUBLICATION NUMBER			DATE			TITLE		
PAGE NO.	COLM NO.	LINE NO.	NATIONAL STOCK NUMBER	REFERENCE NO.	FIGURE NO.	ITEM NO.	TOTAL NO. OF MAJOR ITEMS SUPPORTED	RECOMMENDED ACTION

**PART III - REMARKS** *(Any general remarks or recommendations, or suggestions for improvement of publications and blank forms. Additional blank sheets may be used if more space is needed.)*

TYPED NAME, GRADE OR TITLE	TELEPHONE EXCHANGE/AUTOVON, PLUS EXTENSION	SIGNATURE
----------------------------	--	-----------



By Order of the Secretary of the Army:

PETER J. SCHOOMAKER  
*General, United States Army*  
*Chief of Staff*

Official:

  
SANDRA R. RILEY  
*Administrative Assistant to the*  
*Secretary of the Army*  
0513903

DISTRIBUTION:

To be distributed in accordance with the initial distribution number (IDN) 381144, requirements for TM 9-2320-303-24-2.



## THE METRIC SYSTEM AND EQUIVALENTS

<p><b>Linear Measure</b></p> <p>1 Centimeter = 10 Millimeters = 0.01 Meters = 0.3937 Inches          1 Meter = 100 Centimeters = 1000 Millimeters = 39.37 Inches          1 Kilometer = 1000 Meters = 0.621 Miles</p> <p><b>Weights</b></p> <p>1 Gram = 0.001 Kilograms = 1000 Milligrams = 0.035 Ounces          1 Kilogram = 1000 Grams = 2.2 Pounds          1 Metric Ton = 1000 Kilograms = 1 Megagram = 1.1 Short Tons</p> <p><b>Liquid Measure</b></p> <p>1 Milliliter = 0.001 Liters = 0.0338 Fluid Ounces          1 Liter = 1000 Milliliters = 33.82 Fluid Ounces</p>	<p><b>Square Measure</b></p> <p>1 Sq Centimeter = 100 Sq Millimeters = 0.155 Sq Inches          1 Sq Meter = 10,000 Sq Centimeters = 10.76 Sq Feet          1 Sq Kilometer = 1,000,000 Sq Meters = 0.386 Sq Miles</p> <p><b>Cubic Measure</b></p> <p>1 Cu Centimeter = 1,000 Cu Millimeters = 0.06 Cu Inches          1 Cu Meter = 1,000,000 Cu Centimeters = 35.31 Cu Feet</p> <p><b>Temperature</b></p> <p><math>5/9 (^{\circ}\text{F} - 32) = ^{\circ}\text{C}</math>          212° Fahrenheit is equivalent to 100° Celsius          90° Fahrenheit is equivalent to 32.2° Celsius          32° Fahrenheit is equivalent to 0° Celsius  <math>9/5 \text{ C}^{\circ} + 32 = \text{F}^{\circ}</math></p>
--	--

## APPROXIMATE CONVERSION FACTORS

To Change	To	Multiply By
Inches	Centimeters	2.540
Feet	Meters	0.305
Yards	Meters	0.914
Miles	Kilometers	1.609
Sq Inches	Sq Centimeters	6.451
Sq Feet	Sq Meters	0.093
Sq Yards	Sq Meters	0.836
Sq Miles	Sq Kilometers	2.590
Acres	Sq Hectometers	0.405
Cubic Feet	Cubic Meters	0.028
Cubic Yards	Cubic Meters	0.765
Fluid Ounces	Milliliters	29.573
Pints	Liters	0.473
Quarts	Liters	0.946
Gallons	Liters	3.785
Ounces	Grams	28.349
Pounds	Kilograms	0.454
Short Tons	Metric Tons	0.907
Pound-Feet	Newton-Meters	1.356
Pounds per Sq Inch	Kilopascals	6.895
Miles per Gallon	Kilometers per Liter	0.425
Miles per Hour	Kilometers per Hour	1.609

To Change	To	Multiply By
Centimeters	Inches	0.394
Meters	Feet	3.280
Meters	Yards	1.094
Kilometers	Miles	0.621
Sq Centimeters	Sq Inches	0.155
Sq Meters	Sq Feet	10.764
Sq Meters	Sq Yards	1.196
Sq Kilometers	Sq Miles	0.386
Sq Hectometers	Acres	2.471
Cubic Meters	Cubic Feet	35.315
Cubic Meters	Cubic Yards	1.308
Milliliters	Fluid Ounces	0.034
Liters	Pints	2.113
Liters	Quarts	1.057
Liters	Gallons	0.264
Grams	Ounces	0.035
Kilograms	Pounds	2.205
Metric Tons	Short Tons	1.102
Newton-Meters	Pound-Feet	0.738
Kilopascals	Pounds per Sq Inch	0.145
Kilometers per Liter	Miles per Gallon	2.354
Kilometers per Hour	Miles per Hour	0.621

